



1ZSE 2750-107 en, Rev. 2

Transformer bushings, type GOH

Technical guide

This Technical guide has been produced to allow transformer manufacturers, and their designers and engineers, access to all the technical information required to assist them in their selection of the appropriate transformer bushing. The guide should be used in conjunction with the *Selection guide* to allow the optimum selection to be made.

The technical information pertaining to bushings manufactured by ABB has been divided into separate documents, with one document for each type.

The information provided in this document is intended to be general and does not cover all possible applications. Any specific application not covered should be referred directly to ABB, or its authorized representative.

ABB makes no warranty or representation and assumes no liability for the accuracy of the information in this document or for the use of such information. All information in this document is subject to change without notice.

Table of contents

Design _____	5
Shed form _____	6
Terminals _____	6
Test tap _____	6
Testing _____	7
Test tap adapter _____	7
Dimensions _____	8
Electrical data _____	9
Common specifications _____	9
Conductor loading _____	10
Connection _____	12
Ordering particulars _____	12
Recommendations for positioning _____	12

Design

The bushing is built up around a solid aluminium bolt which serves as a conductor for both the current and for the heat losses. Cooling flanges are milled directly in the conductor.

The upper insulator, lower insulator and mounting flange are held between the end plates by spring pressures. Sealing is accomplished by oil-resistant rubber gaskets.

The radial seal at the bottom end consists of an O-ring made in a special fluorocarbon rubber. This material is very resistant to high-temperature transformer oil, and has good flexibility in the lower temperature range.

The annular space between the condenser body and the porcelain is filled with transformer oil. A gas-filled expansion space is left at the top.

The oil level can be checked by means of a dipstick in the oil filling hole.

Both insulators are made in one piece of high quality electrical porcelain. The mounting flange is manufactured of corrosion-resistant aluminium alloy.

The mounting flange is protected by painting with two-component primer and a grey-blue finishing coat of paint.

The bushings are delivered oil-filled and ready for use.

The bushing can be vertically or horizontally mounted. If the bushing is horizontally mounted, special measures have to be taken to ensure sufficient oil filling in the bushing and communication with an expansion space. Further information can be obtained on request.

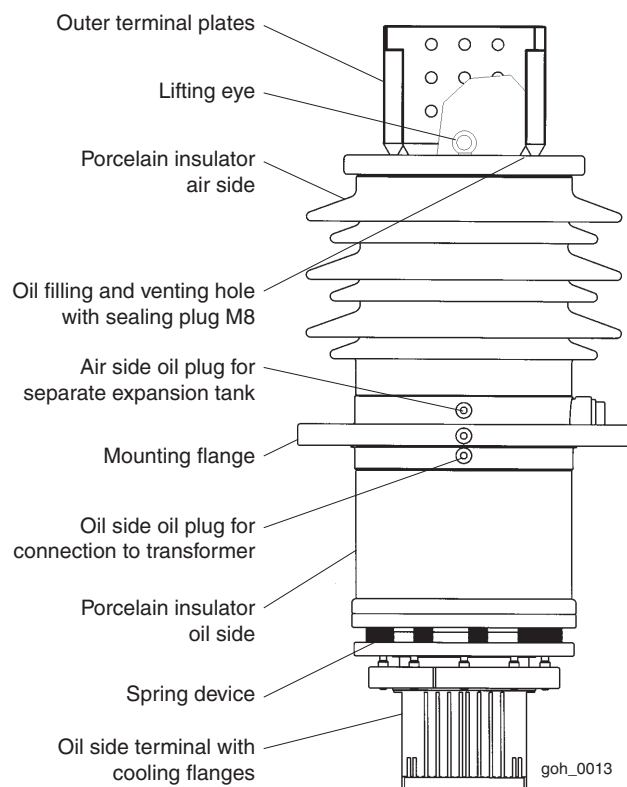

Fig. 1. Transformer bushing type GOH.

Shed form

The shed form for all GOH bushings is of the anti-fog type with alternating long and short sheds. For each pair of sheds the ratio between nominal creepage distance and the axial length is 3.35 and the ratio between protected and nominal creepage distance is 0.40.

According to IEC 60815 the creepage factor C.F. is <3.0 and the profile factor P.F. is >1.1 .

For special customer demands regarding creepage distance, other shed forms may be used.

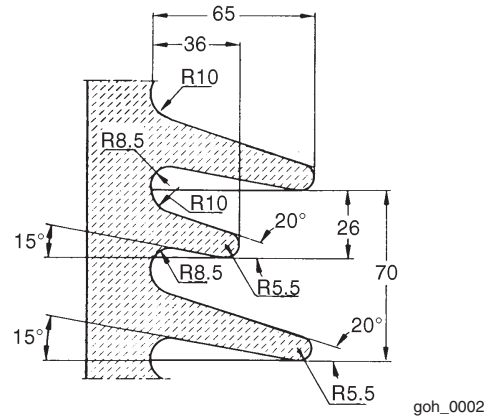

Fig. 2. Shed form.

Terminals

The contact surfaces are plated with a tin/zinc alloy. The oil end is provided with threaded holes. The threads are provided with self locking thread inserts. The oil end has two contact surfaces milled directly in the conductor. The air end is equipped with four drilled flat terminals, welded to the conductor.

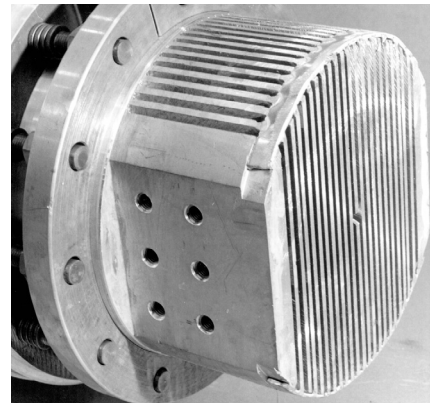

Fig. 3. Oil end.

Test tap

The outer conducting layer of the condenser body is connected to an insulated test tap on the flange. During operation the test tap cover must be screwed on in order to earth the outer layer to the flange. The max. test voltage of the tap is 2 kV, 50 Hz for 1 minute. Max. service voltage is 600 V.

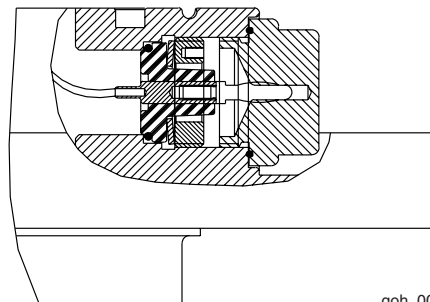

Fig. 4. Test tap.

Testing

During the manufacture and on its completion the bushing is subjected to a number of routine tests. A tightness test is carried out on the assembled bushing after the final drying and impregnation. The test is made with an oil overpressure of 180 kPa (1.8 bar) for 12 hours at ambient temperature. No sign of leakage is allowed.

Each bushing is subjected to a final electrical routine test. The test is made at room temperature with the bushing submerged in oil. Capacitance and $\tan \delta$ are measured in steps up to the power frequency withstand voltage, which is maintained for one minute.

Capacitance and $\tan \delta$ are also measured at decreasing voltage at the same voltage levels as before the one minute test.

Measurements for detection of internal partial discharge (PD measurements) are also made. These measurements are carried out at the same time as the power frequency withstand test. PD measurements are made in steps up to the full test voltage and down. It is always demonstrated that the PD value is max. 5 pC at test voltage equal to the rated system voltage.

Type tests have been carried out according to IEC 60137 and IEEE. Type test reports are available on request.

Test tap adapter

For testing, a special test adapter is required for permanent connection of the test tap to the measuring circuits.

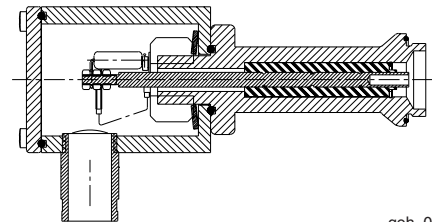

goh_0011

Fig. 5. Test tap adapter, 2769 531-D.

Dimensions

The dimensions in axial direction are the same for standard GOH 170/10, 170/16 and 170/25.

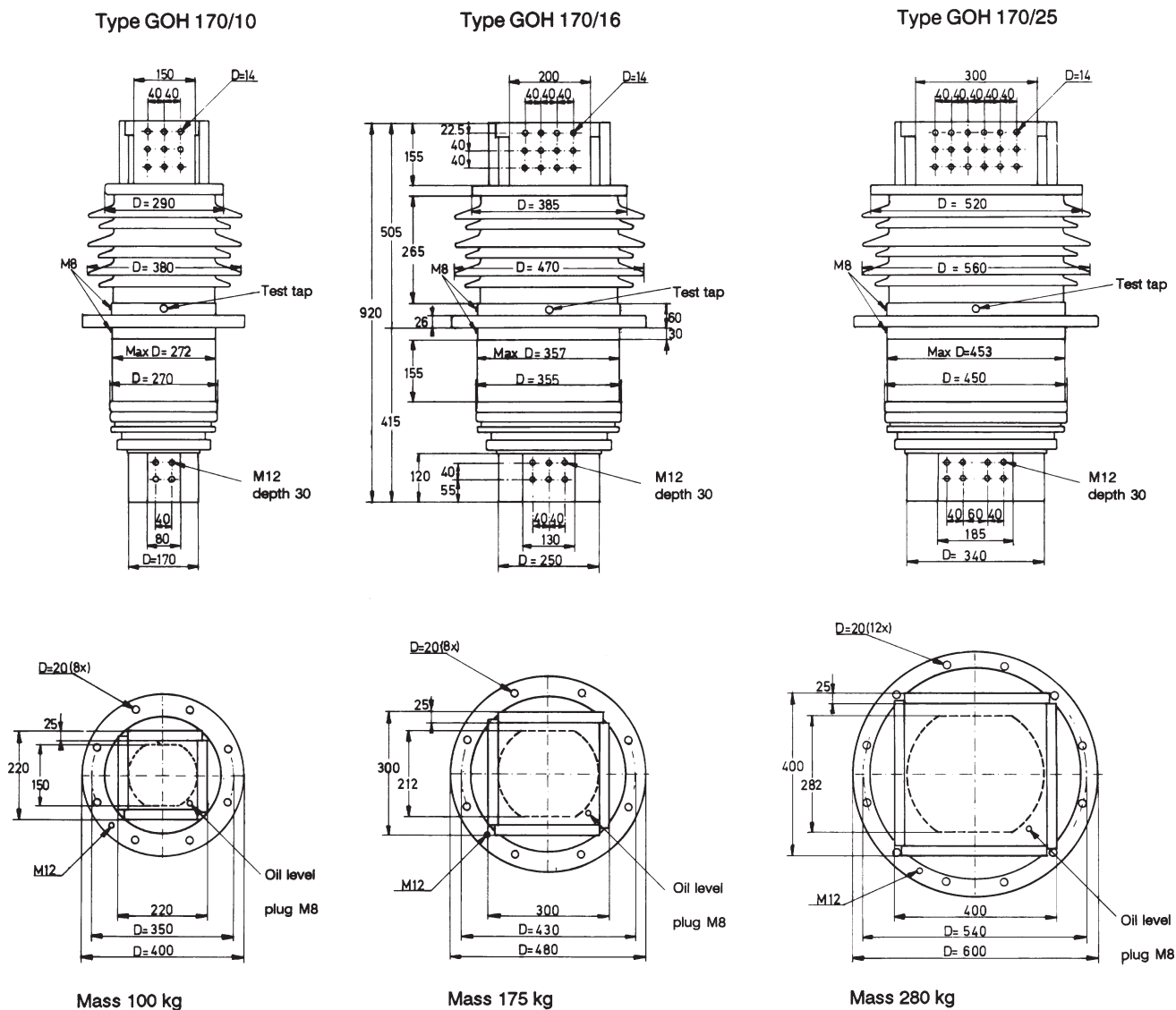

Fig. 6. Dimensions.

goh_0004

Type GOH	Min. creepage distance (mm)		Cantilever withstand load (N)	
	Total	Protected	Operation	1 min. test
170/10	760	300	1575	10000
170/16	760	300	1575	10000
170/25	760	300	1575	10000

Electrical data

The values below are according to IEC 60137 and IEEE.

Type GOH	Rating				Routine test		Short time current		Dynamic current	Nominal capacitance between conductor and test tap C1 ±10 % (pF)
	Nominal voltage U _r kV, RMS	Phase-to-earth voltage kV, RMS	Dry lightning impulse 1.2/50 kV	Wet power frequency AC kV, RMS	1 min ³⁾ dry 50 Hz kV, RMS	Reference current ¹⁾ kA	1 th 1 s kA	1 th 2 s kA	1 Peak kA	
170/10	36	36	200	75	80	10	100 ²⁾	100 ²⁾	250 ²⁾	400
170/16	36	36	200	75	80	16	100 ²⁾	100 ²⁾	250 ²⁾	570
170/25	36	36	200	75	80	25	100 ²⁾	100 ²⁾	250 ²⁾	765

1) See *Conductor loading*

2) Highest value according to IEC 60137.

3) According to IEC 60137.

Common specifications

Application:	Transformers
Classification:	Oil impregnated paper, capacitance graded, outdoor immersed bushing.
Ambient temperature:	+40 °C to -40 °C, minimum value acc. to temperature class 2 of IEC 60137 (-50 °C according to GOST 10693-81 item 2.26)
Altitude of site:	< 1 000 m
Level of rain and humidity:	1-2 mm rain/min. horizontally and vertically as per IEC 60060-1.
Pollution level:	According to specified creepage distance and IEC 60815 (Guide for the selection of insulators in respect of polluted conditions)
Immersion medium:	Transformer oil (see <i>Conductor loading</i>)
Oil level in transformer:	Not lower than 25 mm from the bushing flange.
Max. pressure of medium:	100 kPa over pressure.
Mounting angle:	Vertical or horizontal
Markings:	Conforming to IEC/ IEEE

For conditions exceeding the standard specification above, please consult ABB.

Conductor loading

The name plate value of current, also given in the designation of the GOH bushing, is a reference current and not the permissible current for the bushing. The permissible current is very much dependent upon the temperature conditions around the bushing. Knowing the temperature of the surrounding transformer oil and the ambient temperature of the air side of the bushing, one can calculate the permissible current by using the diagram in Fig. 7. This diagram is verified by thermal tests which are in accordance with IEC 60137.

- t_1 Highest temperature (hot spot) allowed on the bushing. In normal service this should not exceed 105 °C.
- t_{A1} Ambient temperature on air side of the bushing. This depends greatly on whether the bushing is enclosed or not, and if enclosed, on how the enclosure is designed.
- t_0 Temperature of the oil around the bushing. With forced cooling t_0 is often relatively low compared to the maximum allowed temperature given in transformer standards.
- t_{A2} Mean daily ambient temperature around the transformer.
- Δt Top oil temperature rise for the transformer.

Example:

$$I = 11 \text{ kA}$$

$$t_{A2} = 30 \text{ °C}$$

$$\Delta t = 55 \text{ K}$$

$$t_0 = t_{A2} + \Delta t$$

$$t_0 = 30 + 55 = 85 \text{ °C}$$

$$t_{A1} = 45 \text{ °C}$$

$$t_1 = 105 \text{ °C}$$

$$t_1 - t_0 = 105 - 85 = 20 \text{ K}$$

$$t_1 - t_{A1} = 105 - 45 = 60 \text{ K}$$

The permissible current is obtained from the diagram.

For GOH 170/10	9.3 kA
For GOH 170/16	15.2 kA
For GOH 170/25	23.0 kA

GOH 170/16 will in this case be chosen.

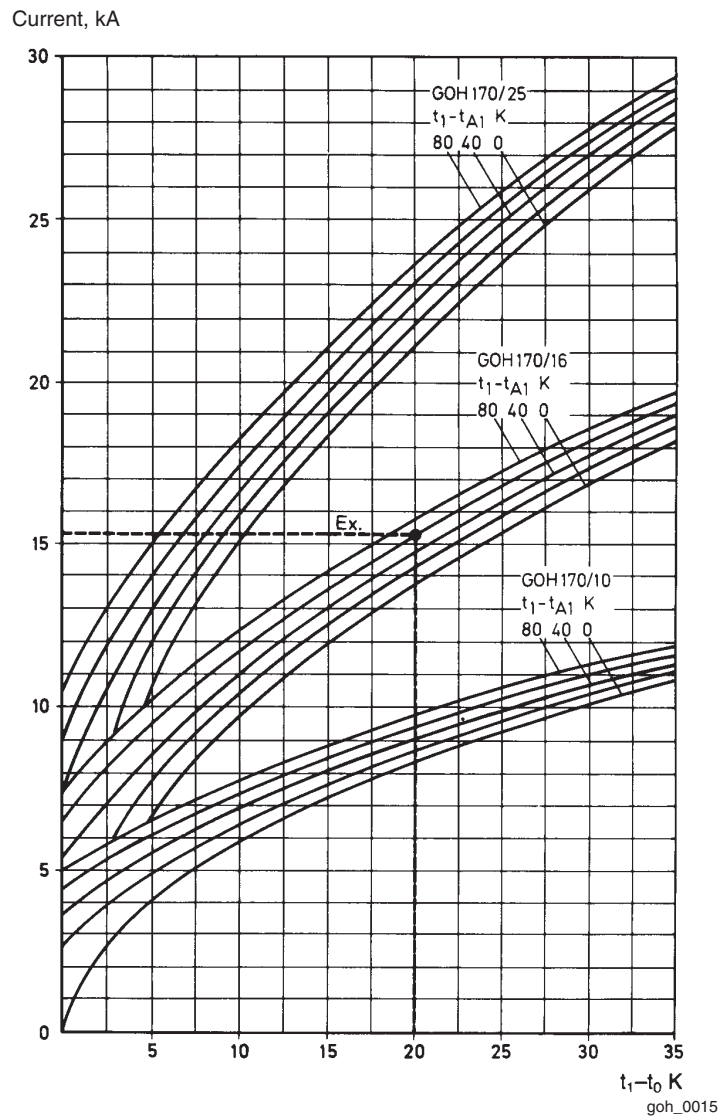
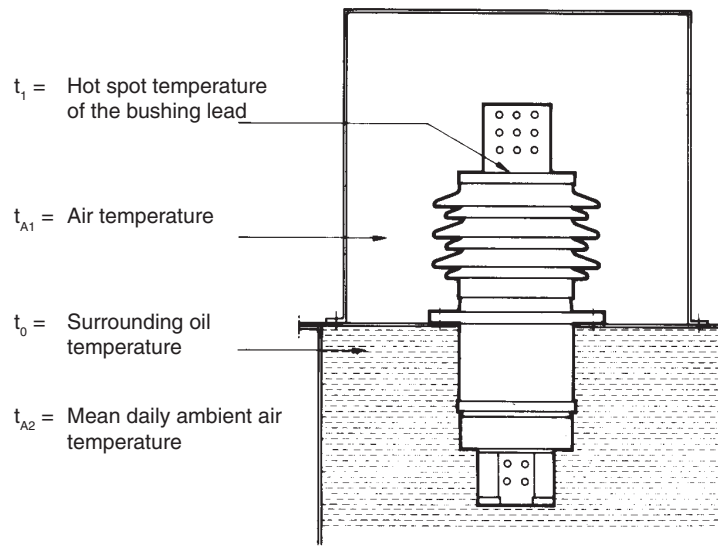

Fig. 7. Current capacity

Connection

The connection to the aluminium terminals of the bushing shall be made by means of flexible connectors. No special treatment is needed for the tin/zinc plated contact surfaces.

In order to maintain a sufficient contact pressure, the screws should be furnished with strong spring washers. Large flat washers must also be used in order to limit the specific load. For M12 and 1/2" UNC, a flat washer with a minimum thickness of 3 mm and a minimum outer diameter of 32 mm is recommended. Detailed instructions and recommendations for connecting are available in the installation and maintenance guide 2750 515-85.

Ordering particulars

When ordering, please state:

- Type and catalogue number for bushings.
- Additional accessories or modifications.
- Test required, in addition to the normal routine tests.
- Test tap adapter, if required.

Designation	Catalogue No.	Insulator colour on air side
GOH 170/10	LF 126 007-A	Brown
	LF 126 007-B	Light grey
GOH 170/16	LF 126 008-A	Brown
	LF 126 008-B	Light grey
GOH 170/25	LF 126 009-A	Brown
	LF 126 009-B	Light grey

Recommendations for positioning

The maximum stresses in the oil at the surface of the shield insulation must be limited to those values normal for insulated conductors and similar components in the same transformer.

The adjacent recommendations are intended as guide lines when complete calculations are not carried out.



ABB		Ludvika, Sweden	
GOH170/10	LF126007-A	No. xxxxxxxx	190x
Ur/Uy	36/36	kV Ir	415 A 50/60 Hz
Lj	200	kV SI	kV AC 80 kV
M	100	kg L	415 mm ▷ 0/90°
C1	400	pF Tan δ	0,32 x
C2	415	pF Tan δ	0,45 x

goh_0014

Nameplate with marking example.

Fig. 8. Recommendations for positioning.

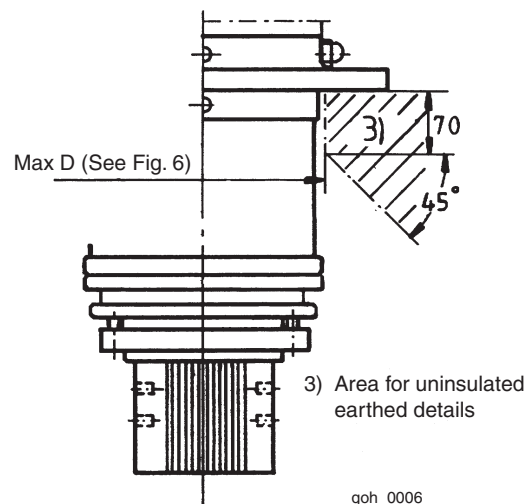
Contact us

ABB AB

Components

SE-771 80 Ludvika, Sweden

Phone: +46 240 78 20 00

Fax: +46 240 121 57

E-Mail: sales@se.abb.com

www.abb.com/electricalcomponents