



Service Advisory Update
April 6, 2005

Original Service Advisory
August 14, 1998

In the recent past, we have had several reports of low voltage bushings filling with oil while in service. The ratings are 15kV through 69kV, 1200 amps and under. We have manufactured approximately 51,000 units since 1987 and have 165 reported cases. In our continuing effort to be Totally Customer Focused we are issuing this advisory.

PRODUCT

ABB "O Plus C", "EEMAC / CSA" and Type "T" condenser bushings 15 kV through 69kV, 1200 amps and under.

GENERAL

These bushings are manufactured with a threaded gasket at the joint between the top of the spring assembly and the clamping nut. This gasket is threaded into position after the bushing is compressed in the assembly operation. If the gasket is not in the proper orientation it results in a slow leak path between the inside of the bushing and the inside of the conductor tube. This can result in filling of the bushing with transformer oil and elimination the gas space. Under extreme thermal changes, the top end seal can be compromised.

RECOMMENDATION

Monitor oil levels on these bushings. Under normal operating conditions, if the oil level is within an inch of the top of the sight glass the bushing should be removed at the first opportunity. If the bushing appears to be empty or completely full of oil, it should be taken out of service immediately.

REPAIR OR REPLACEMENTS

From this date forward (April 6, 2005), ABB will pro-rate the charge for bushings based on age of the bushing.

Units less than 10 years of age	No Charge order to be placed
Units 10-14 years of age	33% of New Bushing Pricing
Units 15-19 years of age	50% of New Bushing Pricing
Units 20-24 years of age	75% of New Bushing Pricing
Units 25 years and above	100% of New Bushing Pricing

Tim Huff
Total Quality Manager

ABB Inc.



Service Advisory Update
April 6, 2005

Original Service Advisory Addendum
October 12, 1998

This addendum provides additional details to the original service advisory dated August 14, 1998. These Details are specifically related to type T condenser bushings, 15 kV through 69 kV, 1200 amps and under.

Based on further evaluation of threaded gaskets applied to type T bushings, ABB Components has determined that its use was limited to certain styles. It should be noted that no related field problems have been received to date. These styles are listed below with the correct oil level at 25 degrees centigrade.

STYLE*	OIL LEVEL (Inches)
025T0120HA	1.75
025T0120HD	1.75
025T0120HK	1.75
034T0120HA	1.75
034T0040HC	1.75
034T0040HF	1.75
034T0040HK	1.75
034T0120HM	1.75
034T0120HP	1.75
034T0040LC	1.50

*A "U" replaces the "T" in the style number for the chocolate porcelain version.

All the above bushings are for horizontal application. Type T bushings for vertical applications are not included in the advisory.

If the oil level as measured with a dipstick is not within +/- .25 inches of the correct level (at 25°C); the bushing should be removed at the first opportunity. The dipstick should be a device that does not introduce foreign particles into the oil and eliminates the opportunity to be dropped into the expansion chamber. If you have questions about the appropriate oil level at other than 25°C, contact ABB.

The transformer must be de-energized before sampling the oil level in the type T.

The attached sketch shows the location of the oil measurement location for the type T, 1200 amps and below.

From this date forward (April 6, 2005), ABB will pro-rate the charge for bushings based on age of the bushing.

Units less than 10 years of age	No Charge order to be placed
Units 10-14 years of age	33% of New Bushing Pricing
Units 15-19 years of age	50% of New Bushing Pricing
Units 20-24 years of age	75% of New Bushing Pricing
Units 25 years and above	100% of New Bushing Pricing

Tim Huff
Total Quality Manager

ABB Inc.



Frequently Asked Questions Regarding the Service Advisory Dated August 14, 1998

How many bushings have been reported to be filling with oil?

ABB has built approximately 51,000 of these bushings since 1987. There have been less than 40 reports of this phenomena.

What are the style numbers of the affected bushings?

All "O Plus C", "EEMAC / CSA" and Type" T" condenser bushings 15 kV through 69 kV, 1200 amps and under.

What is the serial number range included in the advisory?

Serial numbers are not an effective tool in identifying these bushings.

When were these bushings manufactured?

Prior to 1997.

What is the normal oil level in the bushing?

Oil levels in these bushings vary. At 25 degrees C the dimension from the bottom of the sight glass to the oil level can be from 0.75 inch to 2.375 inches depending on the style number.

How do we identify a problem bushing?

If the oil level has risen since the last inspection or is near the top of the sight glass the bushing is suspect and should be monitored weekly.

How do we know if the bushing oil level has increased since installation?

Your original inspection records should be used as a benchmark.

When should a bushing be removed from service?

Under normal operating conditions, if the oil level is within an inch of the top of the sight glass the bushing should be removed at the first opportunity. If the bushing appears to be empty or completely full of oil, it should be taken out of service immediately.

What corrective action is being taken by ABB to eliminate this problem?

ABB has and is conducting ongoing training, provided special tools to ensure proper assembly and conducts process audits weekly. In addition, this is a priority issue for our bushing shell redesign initiative.

ABB Inc.



TYPICAL OIL LEVEL MEASUREMENT
LOCATION FOR HORIZONTAL TYPE T
BUSHINGS, 1,200 AMPS AND BELOW



ABB Power T&D Company Inc.
Components Division
1128 Highway 412 S., Alamo, TN 38001

ABB Inc.



TYPICAL BUSHING CROSS-SECTION

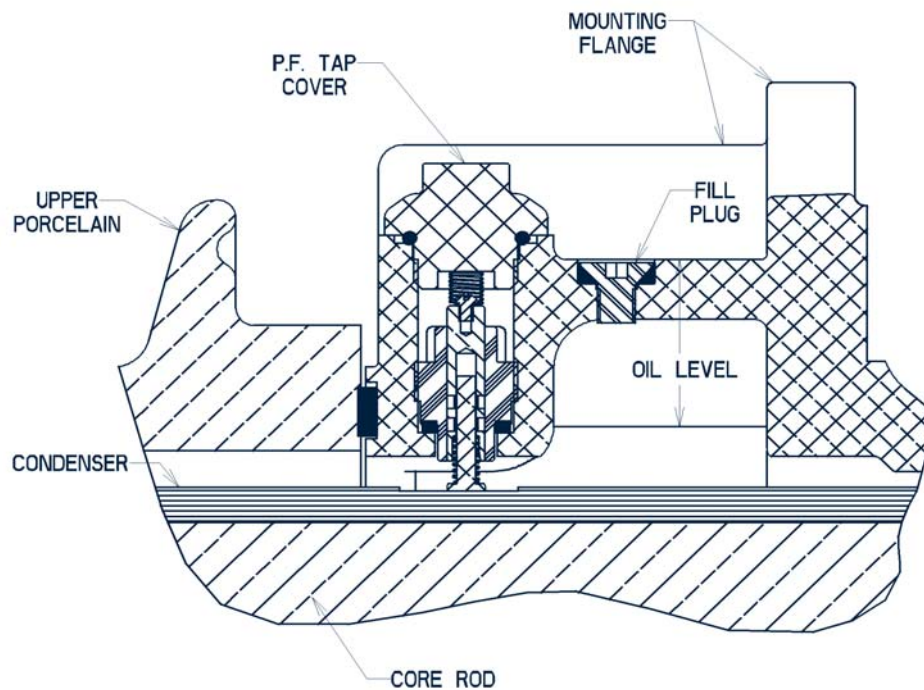
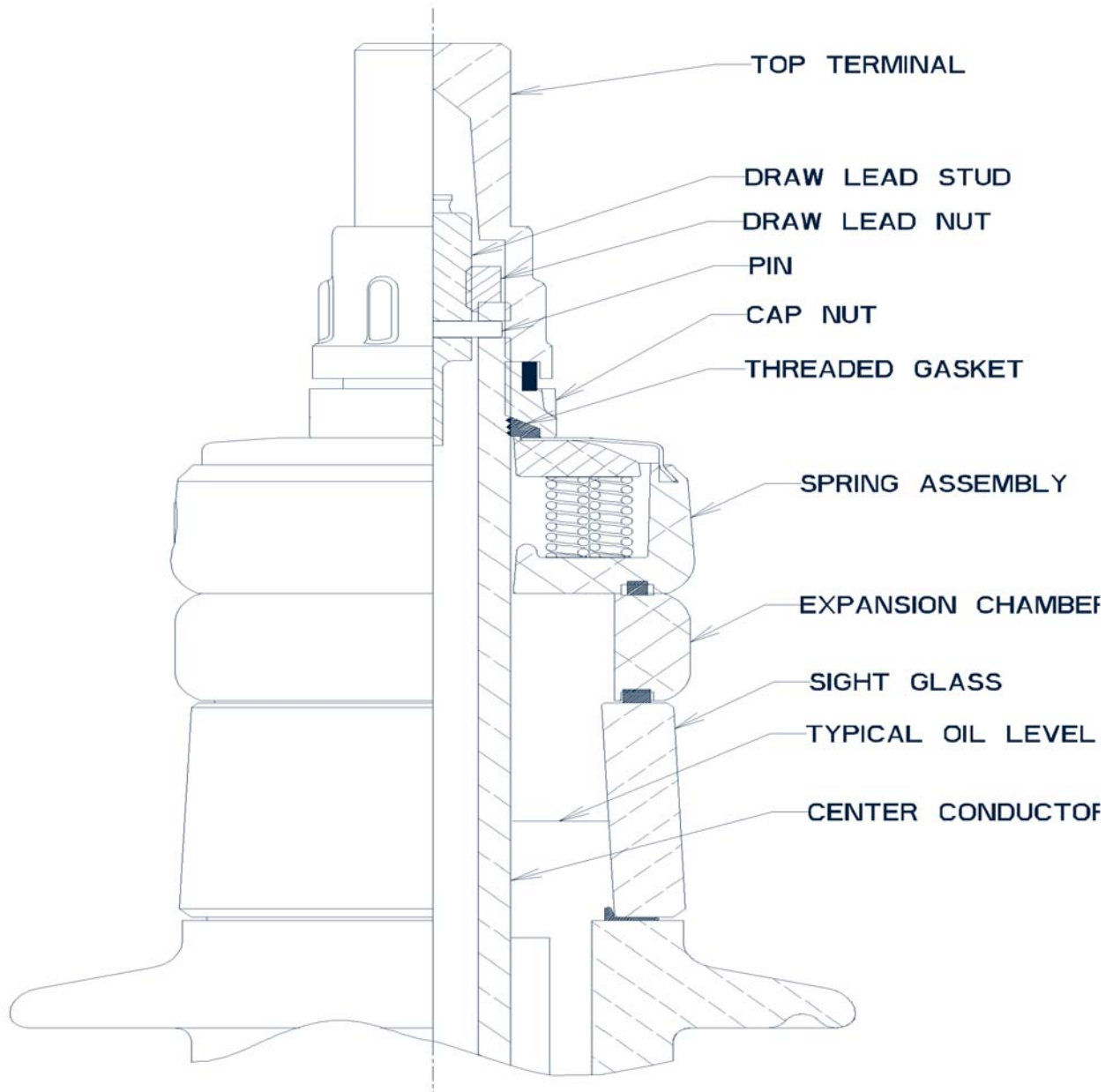

ABB Inc.