



2750 515-85 en, Rev. 9

Transformer bushings, type GOH Installation and maintenance guide

This document must not be copied without our written permission, and the contents thereof must not be imparted to a third party nor be used for any unauthorized purpose. Contravention will be prosecuted.

Safety information

Keep this instruction available to those responsible for the installation, maintenance, and operation of the bushing.

The installation, operation, and maintenance of a bushing present numerous potential unsafe conditions, including, but not limited to, the following:

- High pressures
- Lethal voltages
- Moving machinery
- Heavy components
- Slip, stumble or fall

Specialized procedures and instructions are required and must be adhered to when working on such apparatus. Failure to follow the instructions could result in severe personal injury, death, and/or product or property damage.

Additionally, all applicable safety procedures such as regional or local safety rules and regulations, safe working practices, and good judgement must be used by the personnel when installing, operating, maintaining and/or disposing such equipment.

Safety, as defined in this instruction, involves two conditions:

1. Personal injury or death.
2. Product or property damage (includes damage to the bushing or other property, and reduced bushing life).

Safety notations are intended to alert personnel of possible personal injury, death or property damage. They have been inserted in the instructional text prior to the step in which the condition is cited.

The safety conditions are headed by one of the three hazard intensity levels which are defined as follows:

DANGER

Immediate hazard which will result in severe personal injury, death, or property damage.

WARNING

Hazard or unsafe practice which could result in severe personal injury, death, or property damage.

CAUTION: Hazard or unsafe practice which could result in minor personal injury, or property damage.

Contents

1. Description	6
1.1 Design	6
1.2 Operating conditions	8
1.3 Mechanical loading	8
1.4 Spare parts	8
2. Installation	9
2.1 Tools	9
2.2 Consumables	9
2.3 Transport and handling	9
2.4 Lifting from the box	9
2.5 Mounting	10
2.5.1 Vertical mounting	10
2.5.2 Horizontal mounting	11
2.5.3 Inclined mounting	12
2.5.4 Oil-filling without vacuum (inclined and horizontally mounted)	12
2.5.5 Dismantling	12
2.5.6 Connections	12
2.6 Flange earthing	14
2.7 Waiting time before energizing	14
2.8 Recommended tests before energizing	14
2.8.1 Tightness test between transformer and bushing flange	14
2.8.2 Measurement of capacitance and $\tan \delta$	15
2.8.3 Check of through resistance	16
3. Maintenance	17
3.1 Recommended maintenance and supervision	17
3.1.1 Cleaning of insulator surface	17
3.1.2 Measurement of capacitance and $\tan \delta$	17
3.1.3 Thermovision (infrared camera) check for local overheating on connectors	17
3.1.4 Check for leakage	17
3.1.5 Checking and adjustment of the oil level	17
3.2 Disposal after end of service life	18

1. Description

1.1 Design

The GOH bushings are of the capacitance graded oil-impregnated paper type. The conductor consists of a solid aluminium cylinder with cooling flanges at the oil side.

The design and dimensions of bushings type GOH are given in the Technical Guide, **1ZSE 2750-107**. The design principle is also shown in Figs 1a-b. The air-side terminal plates and the oil-side connections surfaces are, as standard, plated with a tin-zinc alloy, called firinite. Both sides of the terminal plates at the air-side, are plated and can be used for connection. All GOH bushings are equipped with a test tap, connected to the outer layer of the condenser core. The test tap can be used for checking of the bushing insulation by capacitance and dissipation factor measurements. The maximum test voltage for the test tap is 2 kV, one minute at 50 to 60 Hz. It serves as a test tap, and in connection with an external capacitance it can be used as a voltage tap. The operation voltage is limited to 600 V. For connection of the test cable an adapter, according to Fig. 3, should be used. An adapter is available for permanent connection to measuring circuits, see Fig. 4.

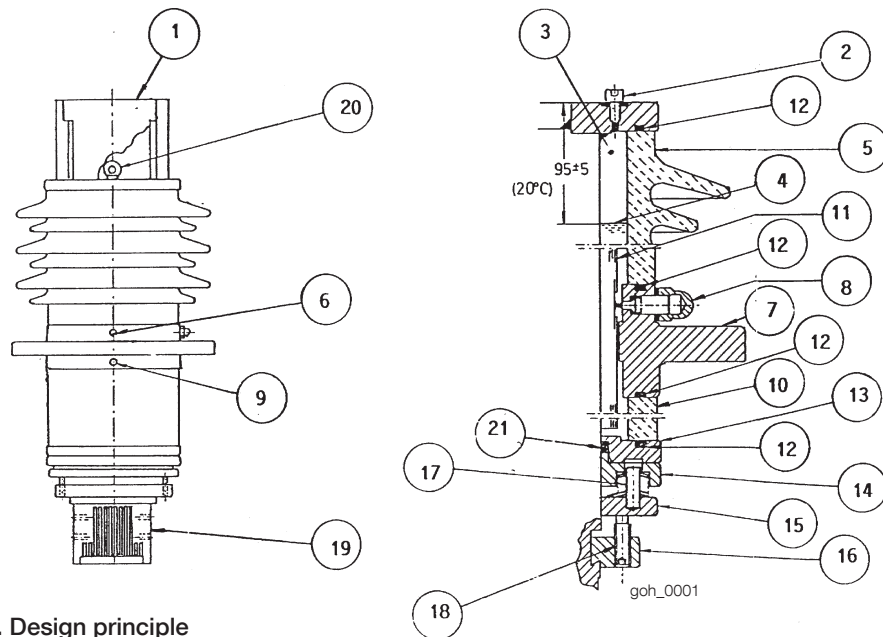

Fig. 1a. Design principle

- 1) Outer terminal plates
- 2) Oil filling and venting plug M8, 2522 731-A
- 3) Expansion space
- 4) Oil
- 5) Porcelain insulator
- 6) Air side oil plug, M8, for separate expansion tank, 2522 731-A
- 7) Mounting flange with one M12 threaded hole for earth connection
- 8) Test tap
- 9) Oil side plug, M8, for connection to the transformer 2522 731-A
- 10) Porcelain insulator

- 11) Capacitance graded core
- 12) Sealing
- 13) Bottom plate
- 14) Guiding ring
- 15) Press ring
- 16) Locking ring
- 17) Spring device
- 18) Locking screws
- 19) Oil side terminal and cooling flanges
- 20) Lifting eye
- 21) Radial sealing

Fig. 1b. Sealing plug 2522 731-A.

- 1) Bolt with flange DIN 6921, 2121 738-18
- 2) Gasket, 2152 899-132

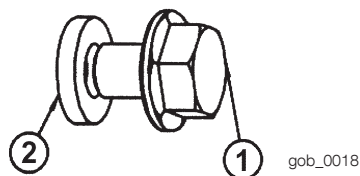
**Fig. 2. Test tap 2769 531-B (not self-earthing)**

- 1) Bushing for test tap
- 2) Belleville spring washer
- 3) Press nut
- 4) Cover 2749 528-B with O-ring 2152 484-2
- 5) Contact pin, 4 mm
- 6) O-ring
- 7) O-ring
- 8) Cable

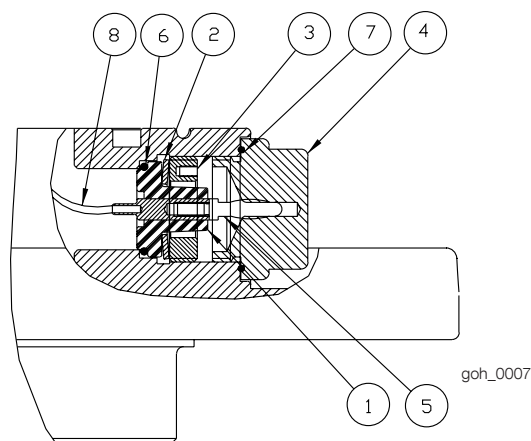
**Fig. 3. Adapter for temporary connection to test equipment 2749 510-4.**

- 1) Temporary connection
- 2) Test tap

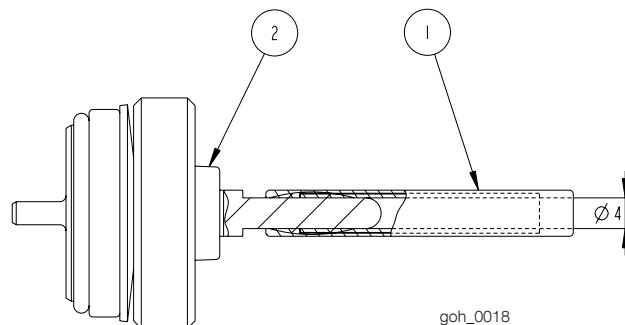
**Fig. 4. Adapter for permanent connection to measuring circuits 2769 531-D.**

- 1) Cover
- 2) Box
- 3) Cable gland Pr (screwed steel conduit) 22.5 (Pg 16 acc. to DIN 40430)
- 4) Protecting resistor, 10 k Ω , 5 W
- 5) Earthing connection (to be removed before connection of outer cable)
- 6) Nut
- 7) Belleville spring washer
- 8) Connector to test tap
- 9) O-ring

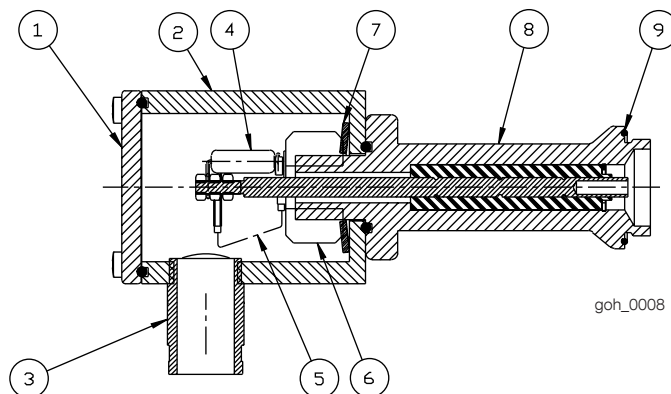

1.2 Operating conditions

The table below shows the standard technical specifications for the GOH Oil - Air bushings. For conditions exceeding the below values, please contact ABB.

Common specifications:

Application:	Transformers
Classification:	Oil impregnated paper, capacitance graded, outdoor-immersed bushing
Ambient temperature:	+40 to -40 °C, minimum value as per temperature class 2 of IEC 60137 ¹⁾ (-50 °C according to GOST 10693-81 item 2.26)
Altitude of site:	< 1 000 m
Level of rain and humidity:	1-2 mm rain/min horizontally and vertically, as per IEC 60060-1
Pollution level:	According to specified creepage distance and IEC 60815 ("Guide for the selection of insulators in respect of polluted conditions")
Type of immersion medium:	Transformer oil ¹⁾
Mounting angle:	0-45° from vertical, or horizontal
Oil level below bushing flange:	Maximum 25 mm
Max. pressure of medium:	100 kPa overpressure
Markings:	Conforming to IEC/ IEEE

¹⁾ See Technical Guide, **1ZSE 2750-107**, section Conductor loading.

1.3 Mechanical loading

The bushings are designed for the following cantilever loads applied to the midpoint of the top end terminal, perpendicularly to the bushing axis. The bushing mounting angle can be 0-45° from vertical, or horizontal.

Table 1. Mechanical loading

Bushing	Type test load 1 minute (N)	Max. service load (N)
GOH 170/10	10000	1575
GOH 170/16	10000	1575
GOH 170/25	10000	1575

1.4 Spare parts

In case of major damage to the bushing we recommend that it is sent back to ABB for possible repair and re-testing. Certain parts (Figs. 1, 2, 8 and 9), which may be damaged or lost during transport or installation, can be ordered from ABB.

2. Installation

2.1 Tools

- Soft slings
- Torque wrench key for hexagon head screws, head width 18 mm (M12)
- Key for hexagon socket head cap screw 6 mm. (Only for previous design of test tap cover)

2.2 Consumables

- Water free vaseline, Mobilgrease 28 or other lubricant not harmful to the transformer oil, to lubricate screws that come into contact with the transformer oil.
- Mobilgrease 28 or other suitable grease to lubricate and protect the earthing screw.

2.3 Transport and handling

CAUTION: The bushing shall be transported and stored vertically, with the top end upwards. Keep the bushings dry and clean and protected against mechanical damage.

Keep the bushings protected from penetrating water when stored outdoors. This means that the case must not be stored in areas where it can be foreseen that the ground will be wet and muddy during heavy rains. Shelter the case from rain and snow with a tarpaulin or roofing.

Carefully inspect the bushing on receiving with regard to shipping damage. Please note that the bushing has been routine tested in oil and some oil may be left, especially in the narrow opening between porcelain and flange.

The bushings are normally delivered from ABB in wooden boxes. The boxes are marked with "Top End". All terminal contact surfaces are greased with vaseline before delivery.

2.4 Lifting from the box

WARNING

For lifting the bushing from the box, apply a clean lifting sling in the lifting eye as shown in the figure below. Lifting lugs placed in the terminal holes are not permitted because the terminal surfaces might be damaged.

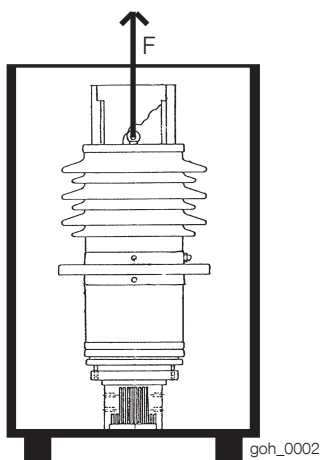

Fig. 5. Lifting from the box.

2.5 Mounting

WARNING

Lift the bushing to vertical or horizontal position according to the figures below. Use a soft bedding under the bottom end of the bushing, e.g. a rubber mat.

The mass of the bushing is stated on the marking plate. Carefully clean and inspect the oil end of the bushing before mounting on the transformer. The contact surfaces of the bushing are plated, as standard, with tin-zink alloy and no special treatment of the surface is required.

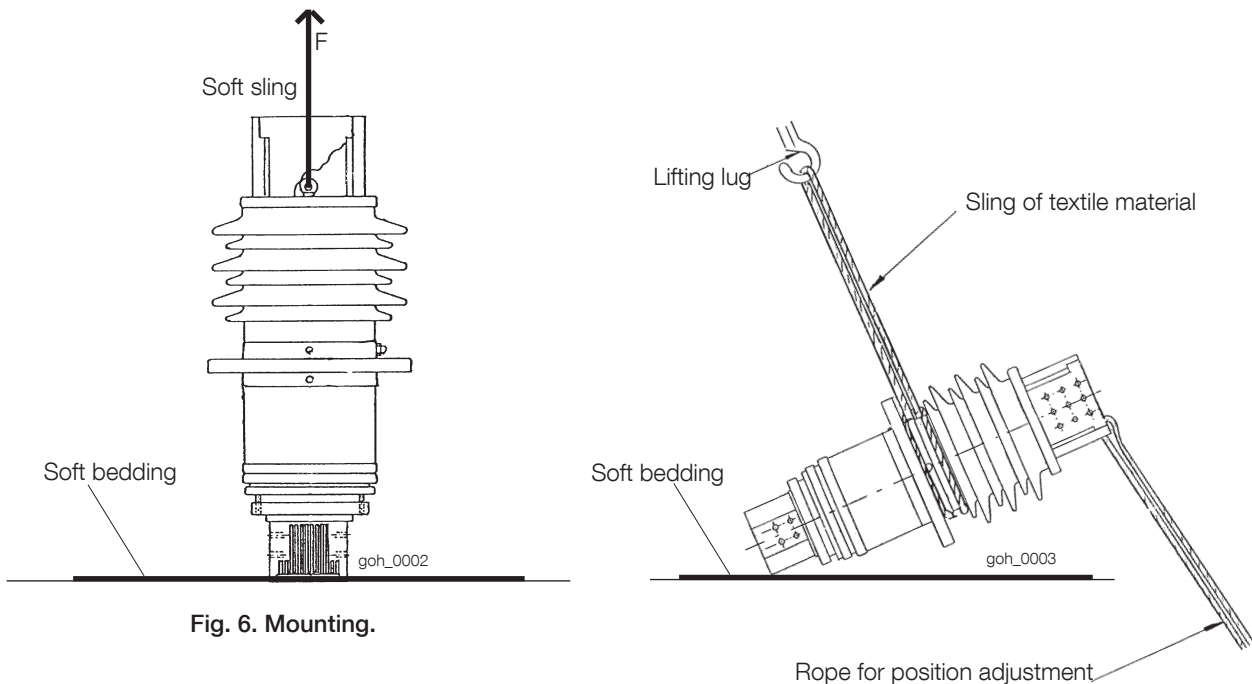

2.5.1 Vertical mounting

When bushings type GOH are vertically mounted, the bushing's own expansion system is used. The sealing plugs (Fig. 7, Pos. 1 and Pos. 2) shall not be removed.

For filling without vacuum, see section 2.5.4.

Risk of gas bubble evolution during transformer factory test

When the temperature of a sealed oil impregnated bushing is increased, the thermal expansion of the oil increases the pressure, and nitrogen from the expansion space is dissolved into the oil. At rapid cooling, the oil becomes oversaturated and bubbles may appear. Such bubbles have caused partial discharges and dielectric failures at transformer factory tests where a heat run was followed by fast cooling and dielectric testing.

In cases where experience shows that a GOH bushing in combination with a test sequence has generated bubbles, it is recommended to manage the situation by ventilating the bushing during the heat run and during the following dielectric tests. It is not necessary to pressurize the bushing during the dielectric tests.

If the heat run has been performed with the bushing sealed and unexpected bubbles and partial discharges appear at dielectric tests, the bushing can be opened at this stage. GOH bushings are filled with degassed oil and sealed with a gas cushion at atmospheric pressure in the top expansion space. During transport and handling, some of the gas molecules are dissolved into the oil and the bushing operates at a pressure below atmospheric. Ventilating the bushing at transformer dielectric tests will increase the pressure to atmospheric and thus instantly diminish the oversaturation.

GOH bushings mounted horizontally or inclined do not generate gas bubbles because the connection to the transformer oil system keeps the bushing oil pressure at a stable level.

A detailed explanation of the gas bubble evolution phenomenon is given in product information **1ZBC000001C2704**, "Gas bubble evolution in oil impregnated bushings".

To ventilate the bushing during the heat run and dielectric tests, loosen the oil filling plug (Fig. 1a, Pos. 2) so that the bushing can breathe. When testing is completed, tighten the plug at atmospheric pressure at a bushing temperature between +5 °C and +35 °C. Tightening torque 20 Nm. It is not necessary to pressurize the bushing with nitrogen when it is sealed.

CAUTION: It is important that the bushing is properly sealed when the testing is completed.

Fig. 7. Opening at flange.

- 1) Sealing plug, air side, 2522 731-A
- 2) Sealing plug, oil side, 2522 731-A
- 3) Tapped storage hole for sealing plug

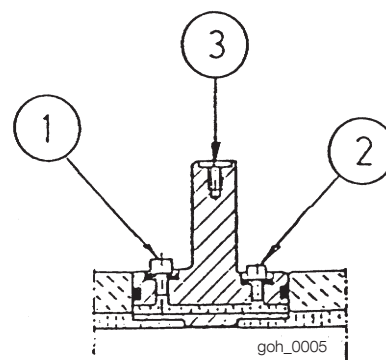

2.5.2 Horizontal mounting

If the bushing is horizontally mounted, the oil side plug at the flange (Fig. 7, Pos. 2) shall be removed with the hole in the **upward** position in the transformer. The plug shall be placed in the tapped hole at the flange edge.

At the oil filling of the transformer under vacuum, the bushing will be completely oil filled and therefore no venting will be needed afterwards. The expansion of the bushing oil will be taken care of by the main oil system of the transformer.

For filling without vacuum, see section 2.5.4.

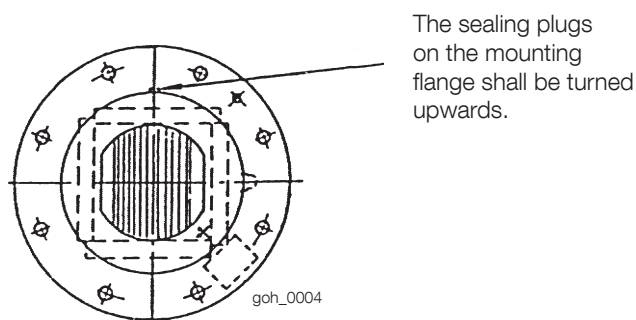

Fig. 8. Horizontal mounting.

2.5.3 Inclined mounting

The bushing can be mounted up to 45° angle from vertical. Larger angles shall not be used because then it is impossible to vent and fill the bushing without vacuum.

For inclined mounting the oil side plug (Fig. 7, Pos. 2) shall be removed and with the hole in downward position in the transformer. The plug shall be placed in the tapped hole at the flange edge. The hole in the top end plate is thus at the highest possible position.

At the oil filling under vacuum the bushing will be completely oil filled and therefore no venting is needed afterwards.

For filling without vacuum, see section 2.5.4.

2.5.4 Oil-filling without vacuum (inclined and horizontally mounted)

In cases when the transformer is not filled under vacuum (e.g. at exchange of bushing at remote places) and the bushing oil system is connected to the main oil system of the transformer, the following instructions are valid.

When the transformer has been filled with oil to the right level, the bushing must be vented. A horizontally mounted bushing shall be vented by the hole on the air side of the flange (Fig. 7, Pos. 1). For inclined up to 45°, the bushing shall be vented by the hole in the top end plate (Fig. 1a, Pos. 2). When it is assured that the bushing is filled, the plug is tightened.

2.5.5 Dismantling

Storing a bushing completely oil filled without expansion space could result in a high internal pressure. For bushings mounted vertically no special precautions are needed after removal, because the bushings are sealed.

For bushings mounted horizontally or inclined, the oil side hole at the flange (Fig. 7, Pos. 2) must be plugged after removal of the bushing. Then place the bushing vertically and adjust the oil level according to Fig. 1 and Table 3. Correct expansion space is important to avoid high excess pressure during storage and transportation.

2.5.6 Connections

CAUTION: Mounting of the conductors must be performed according to the procedure below. The contact surfaces must be clean. The oxide on connected terminals is to be removed according to the instructions below. Failure to perform a proper connection may result in overheating.

Do not use screw of stainless steel or screw with a coating at the oil side terminal.

For the long term stability, it is an advantage to limit the number of materials in the contact. The GOH bushings have contact surfaces of aluminium with a coating of tin and zinc. To get an optimal contact, use aluminium contacts with tin coating. It is not recommended to use bare aluminium because the tin layer does not break through the aluminium oxide. If bare aluminium is used, be sure to remove the oxide as described below. Connections may also be made of copper or copper with tin coating. Silver coating on aluminium or copper may also be used if the adhesion to the substrate can be guaranteed in the actual environment.

Surface treatment method for uncoated surfaces: Use abrasive cloth, type scotch-brite (brown) (first choice) or a stainless steel brush. Apply contact grease (vaseline) on the entire surface and rub (or brush) the surface in two directions until the entire surface has been treated. Remove all the contaminated grease and apply new contact grease on the surface and remove the excess.

Material combination in contacts

Aluminium (no plating)	-	Not recommended
Aluminium + tin plating	++	Preferred choice
Aluminium + silver plating	+	Good
Copper (no plating)	+	Good
Copper + tin plating	+	Good
Copper + silver plating	+	Good

The GOH terminal is provided with many bolt holes for the connection to create a number of distinct areas with defined and relatively high pressure. We recommend a thickness of the opposite contact that is less than the radius of the plain washer. We recommend a flatness deviation not exceeding 0.1 mm and a relatively high surface roughness (Ra 6.3).

Electrical joint compound: For use at the air side we recommend penetrox A (Burndy) or Nikkei S -200 or equal. For use at the terminal inside the transformer, we recommend only unfilled vaseline.

The total contact pressure shall be at least 10 Newton/Ampere. For the M12 screws, we recommend a tightening torque of 60 Nm. All screws shall be lubricated before tightening. We recommend the use of a torque wrench. Use only grease not harmful to the transformer oil.

The oil side terminal bolt holes are furnished with thread inserts the length of the screw must be minimum 18 and maximum 30 mm below the contact surfaces, see Fig. 9. Use only untreated black screw of steel (property class 8.8) at the oil side terminal.

In order to maintain a sufficient permanent contact pressure, every screw at the terminal shall be furnished with spring washers. At the air side, use spring washers on both sides of the terminal plate. Every spring washer shall be placed on a flat washer with larger diameter, see Fig. 9.

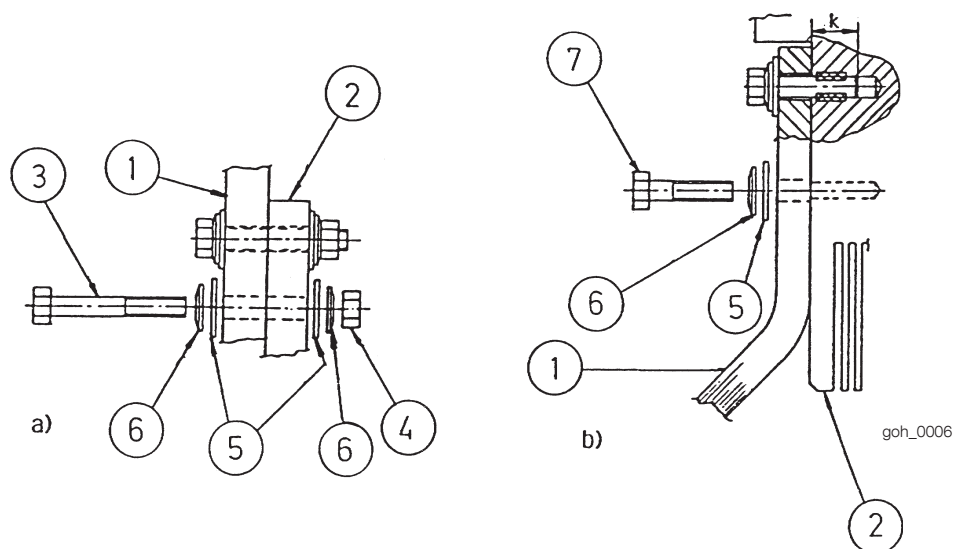
**Fig. 9. Connections****a) Air side b) Oil side**

- 1) Flexible connector
- 2) Terminal plate
- 3) Screw M12 or 1/2"
- 4) Nut
- 5) Flat washer 13 x 34 x 3
- 6) Spring washer 13 x 29 x 3 (34100 N)
- 7) Screw M12, K = min. 18, max. 30

2.6 Flange earthing

The bushing flange is provided with a tapped hole M12. After tightening the bolts fixing the bushing to the transformer tank, the flange should be earthed. Proper earthing is essential. This prevents electrical discharges between bushing flange and transformer tank under normal service conditions.

Alternative 1

Insert a heavily greased (Mobilgrease 28 recommended) pointed set screw M12 (stainless steel A4-80 preferably). Tighten to 40 Nm, penetrating the paint of the transformer tank down to the metal underneath. This makes an electrical connection between the bushing and the transformer tank, keeping them at the same voltage.

Alternative 2

Apply a flexible cable between the M12 earthing hole in the bushing flange and a corresponding connection point in the transformer. Grease the screw (Mobilgrease 28 recommended) and tighten the M12 in the bushing to 40 Nm. Connect the other end of the cable to the transformer.

2.7 Waiting time before energizing

CAUTION: If a bushing, by mistake, has been stored horizontally, it must be raised with the top up for at least 12 hours before service voltage is applied and 24 hours before test voltage is applied. If, by mistake, the bushing has been stored horizontally more than one year, it must be placed in the vertical position for at least one week before energizing. Some waiting time may be necessary before energizing in order to avoid flashovers or partial discharges due to airbubbles at the bushing surface. Choose a suitable procedure below.

Vacuum filled transformer

No waiting time is necessary from the bushing point of view.

De-gassed oil-filled transformer

During mounting, use a clean and dry paintbrush to release surface bubbles. Wait 6 hours before energizing.

Gas-saturated oil-filled transformer

During mounting, use a clean and dry paintbrush to release surface bubbles. Wait 24 hours before energizing.

De-gassed oil filled transformer with reduced oil-level

After restoring the oil-level, wait 24 hours before energizing.

2.8 Recommended tests before energizing

The following tests may be performed to check the insulation, sealing and current path of the bushing. The tests should be made after mounting, but before connecting the outer terminal of the bushing to the rest of the switchyard power circuit.

1. Tightness test between transformer and bushing flange.
2. Measurement of capacitance and $\tan \delta$.
3. Check of through-resistance.

2.8.1 Tightness test between transformer and bushing flange

Several different methods may be used and we thus refer to instructions given by the company responsible for the field erection. As a simple example, the tightness of the seal between transformer and bushing flange may be checked when the transformer is oil-filled by using chalk or, perhaps easier, with paper strips.

2.8.2 Measurement of capacitance and $\tan \delta$

WARNING

The test tap is earthed by the cover.

Since C_2 usually is relatively small, the test tap must never be open-circuited (cover removed) when applying a voltage to the bushing. It shall always be earthed or connected to an external impedance. Without connection, the bushing may be destroyed.

CAUTION: When not measuring, always make sure that the cap nut is properly tightened with the gasket in place. This is to prevent dust and water from coming in to the test tap.

After mounting, a capacitance measurement is recommended. Connect a measuring bridge between the outer terminal and the test tap by using a \varnothing 4 mm lead coupler or ABB's test tap adapter 2749 510-U. This is possible without removing the bushing as the bushing has an insulated test tap, see Fig. 10. More details can be found in the product information **2750 515-142**, "Bushing diagnostics and conditioning".

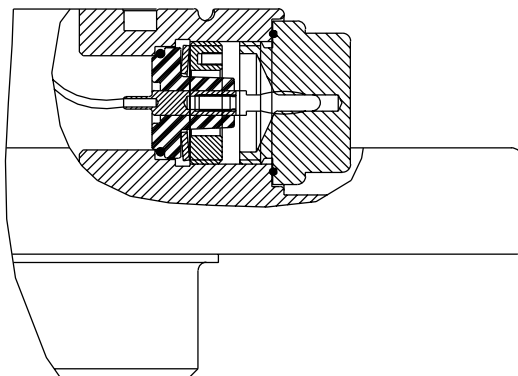

Fig. 10. Test tap 2769 531-B (not self-earthing)

With the transformer de-energized and the bushing outer terminal disconnected, the test tap cover is removed. The measuring equipment is connected to the test tap and the measuring voltage source to the bushing terminal.

The capacitances C_1 between the center conductor and the tap, and the capacitance C_2 , between the test tap and earth are marked on the marking plate. The nominal capacitances C_1 of the different bushing types are listed in Table 2. C_2 is highly dependent on the surrounding parts inside the transformer and it is not possible to give a nominal value valid for all service conditions.

Table 2. Nominal capacitances in pF (Manufacturing tolerances for $C_1 \pm 10\%$).

Type	Catalogue No.	Nominal capacitance (pF)	
		C_1	C_2
GOH 170/10	LF 126 007-	400	415
GOH 170/16	LF 126 008-	570	510
GOH 170/25	LF 126 009	765	540

The dissipation factor varies with the temperature of the bushing core, and the measured value should thus be multiplied with the correction factor (multiplier) given in Table 3.

Table 3. Dissipation factor variations as a function of temperature.

Bushing core temperature °C	Multiplier to 20 °C
3-7	0.85
8-12	0.90
13-17	0.95
18-22	1.00
23-27	1.05
28-32	1.10
33-37	1.15
38-42	1.20
43-47	1.25
48-52	1.30

2.8.3 Check of through resistance

The through-resistance measurement method depends on the design of the transformer. Generally, a current is applied from bushing to bushing. The voltage drop from outer terminal to outer terminal is measured. The resistance is calculated with Ohm's law, $U = R \cdot I$. (U: Measured voltage drop. I: Through current. R: Total circuit resistance.)

The total through resistance is the sum of the transformer winding and lead resistance and the bushing conductor and contact resistance. The additional resistance from the bushing conductor should not be more than 10 ... 100 mΩ. Since the through resistance of the HV winding of a typical power transformer is in the order of 0.1 .. 1 Ω, this is a very rough method that can only be used to detect very large faults in the current path, such as disruptions. Less-than-perfect contacts can only be detected by making a sensitive measurement across each connection point, or by measuring the temperature increase during operation with an infrared sensitive camera (thermovision).

3. Maintenance

The GOH bushings are maintenance-free.

DANGER

No work at all can be performed on the bushing while it is energised or not earthed.

3.1 Recommended maintenance and supervision

1. Cleaning of insulator surface
2. Measurement of capacitance and $\tan \delta$
3. Thermovision (infrared camera) check for local overheating on connectors
4. Check for leakage
5. Checking and adjustment of the oil level

3.1.1 Cleaning of insulator surface

CAUTION: Avoid having solvent on the bushing gaskets.

Under conditions of extreme pollution it may be necessary to clean the porcelain insulator surface. This should be done by water-jet or by wiping with a moist cloth. If necessary, ethyl-alcohol or ethyl-acetate may be used.

3.1.2 Measurement of capacitance and $\tan \delta$

Please refer to Chapter 2 Installation.

3.1.3 Thermovision (infrared camera) check for local overheating on connectors

At maximum rated current, the temperature of the bushing outer terminal normally is about 35 to 45 °C above the ambient air. Significantly higher temperatures, especially at lower current loading, can be a sign of bad connections.

3.1.4 Check for leakage

Make a visual inspection for oil leakage during normal station supervision.

3.1.5 Checking and adjustment of the oil level

CAUTION: Oil sampling and dissolved gas in oil analysis.

Normally we do not recommend taking oil samples or opening our bushings. The bushing is sealed and tightness tested at the time of manufacturing. An oil sampling means that the bushing has to be opened. Thus, there is also a risk of improper sealing after the sampling is finished. However, when a problem is known, for example high power factor over C1 or visible leakage, there might be a need for oil sampling and gas analysis or oil level check. In this case, ask for product information 2750 515-142 "Bushing diagnostics and conditioning".

The oil level in bushings may be checked through the oil filling hole at the top end. A dry and clean dipstick should be used. Correct oil level is shown in Table 4. If the oil level is too high, oil can be sucked out by means of a narrow hose. If the oil level is too low, clean and dry transformer oil must be added. Adjustment of oil level is allowed only when the temperature of the bushing is +5 °C to +35 °C. It is recommended that the sealing plug be provided with a new gasket after the check. The sealing plug is to be tightened with 20 Nm. For further information on oil sampling, see product information 2750 515-142.

For topping-up of the bushing, any clean and dry transformer oil available at site may be used.

Table 4. Oil level.

Type GOH	Oil level at 20 ±10 °C, mm Fig. 1	Oil level change mm/10 °C (The bushing in vertical position)
170/10	95 ±5	2.5
170/16	95 ±5	2.5
170/25	95 ±5	2.5

3.2 Disposal after end of service life

The bushing consists of the following material:

- Conductor of low-alloy aluminium.
- Terminals of low-alloy aluminium plated with tin-zink.
- Transformer oil as per IEC 60296, group I.
- Transformer oil impregnated condenser core consists of paper and 1 % aluminium foils.
- Spring device (rings) consist of aluminium alloys.
- Spring washers and cylindrical pins of steel.
- Previous design of test tap cap consists of plated brass. New design consists of stainless steel.
- Insulators consist of quartz or aluminium silicate based porcelain.

Contact us

ABB AB

Components

SE-771 80 Ludvika, Sweden

Phone: +46 240 78 20 00

Fax: +46 240 121 57

E-Mail: sales@se.abb.com

www.abb.com/electricalcomponents