

Applying IGBT and Diode dies

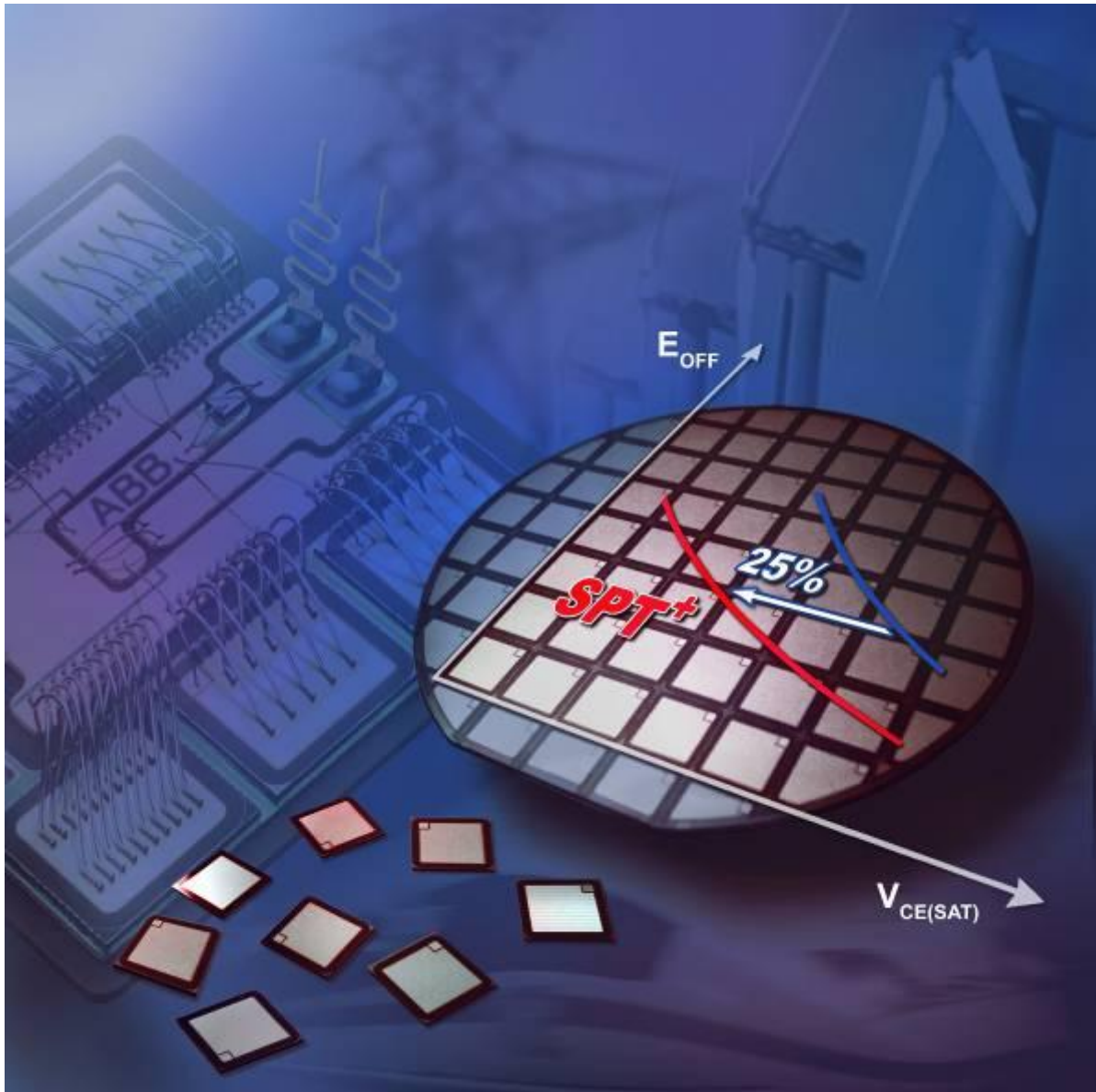

Applying IGBT and Diode dies

Application Note 5SYA 2059-02

Ulrich Schlapbach, Björn Backlund, Andreas Baschnagel,
Roland Fischer, Silvan Geissmann, Raffael Schnell

ABB Switzerland Ltd

Semiconductors

March 2010

Table of Contents

1	INTRODUCTION.....	3
1.1	BACKGROUND	3
1.2	PRODUCT LINE-UP.....	3
1.3	PART NUMBERING SYSTEM	3
1.4	ELECTRO-STATIC DISCHARGE SENSITIVITY.....	4
2	DATA SHEET USERS GUIDE	4
2.1	KEY PARAMETERS AND FEATURES	5
2.2	MAXIMUM RATED VALUES IGBT.....	5
2.3	MAXIMUM RATED VALUES DIODE.....	6
2.4	IGBT CHARACTERISTIC VALUES	7
2.5	DIODE CHARACTERISTIC VALUES	12
2.6	MECHANICAL PROPERTIES	14
2.7	OUTLINE DRAWING	15
2.8	DIAGRAMS IGBT	16
2.9	DIAGRAMS DIODE.....	19
3	TESTING, SHIPMENT, STORAGE AND HANDLING OF IGBT AND DIODE DIES.....	21
3.1	TESTING AT ELEVATED TEMPERATURE.....	21
4	ASSEMBLY RECOMMENDATIONS.....	21
4.1	DIE ATTACHMENT	21
4.2	WIRE BONDING	21
4.3	SURFACE COVERAGE.....	22
5	ADDITIONAL NOTES	22
5.1	REFERENCES.....	22
5.2	APPLICATION SUPPORT.....	22

1 Introduction

1.1 Background

ABB has a well established reputation in the field of high-power electronics. This is reflected in a comprehensive product portfolio covering a wide range of devices such as thyristors, diodes, GTOs, IGBTs and IGCTs with voltages of up to 8.5 kV for demanding Industrial, Traction and Energy Management markets. All our dies are developed and produced at our own facilities in Switzerland with the goal of making IGBTs Best-in-Class in terms of switching performance, ruggedness and reliability. These chips are available to module, press-pack and hybrid manufacturers interested in making world-class power products of their own.

ABB currently produces IGBTs (Insulated Gate Bipolar Transistors) and Diodes in a voltage range of 1200 to 6500 V based on the now well established SPT technology (Soft Punch-Through). SPT technology is characterised by well controlled (“soft”) switching performances and very large Safe Operating Areas (SOA), together with positive temperature coefficients for reliable parallel operation. A new generation of chips, known as SPT⁺, is currently being introduced. SPT⁺ retains all the features of SPT but allows a 20 – 30% reduction in $V_{CE\ sat}$, depending on voltage class.

This application note does not cover any detailed semiconductor physics. For a systematic introduction to the operation principle and physics of power semiconductor devices, including IGBT and diode, we recommend the book “Power Semiconductors” from Stefan Linder, ISBN 0-8247-2569-7 (CRC Press, published in 2006).

1.2 Product line-up

For the current line-up of IGBT- and diode-dies please consult the ABB Switzerland Ltd, Semiconductors internet web site:
<http://www.abb.com/semiconductors>

1.3 Part numbering system

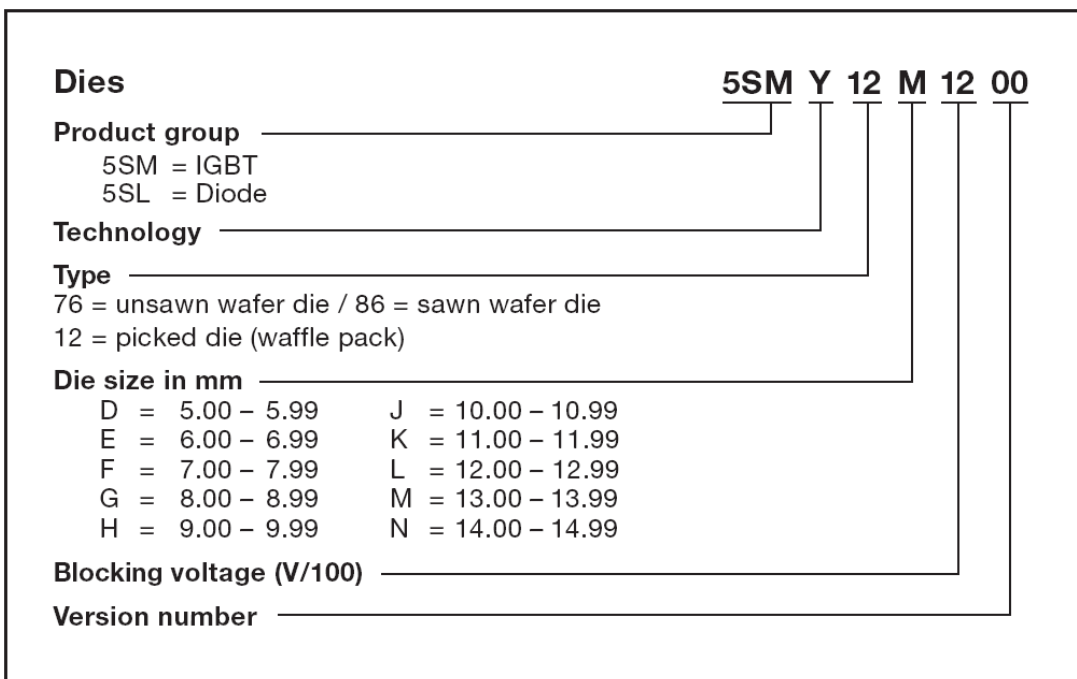

All chip data sheets use Type 12 since they refer to single die.

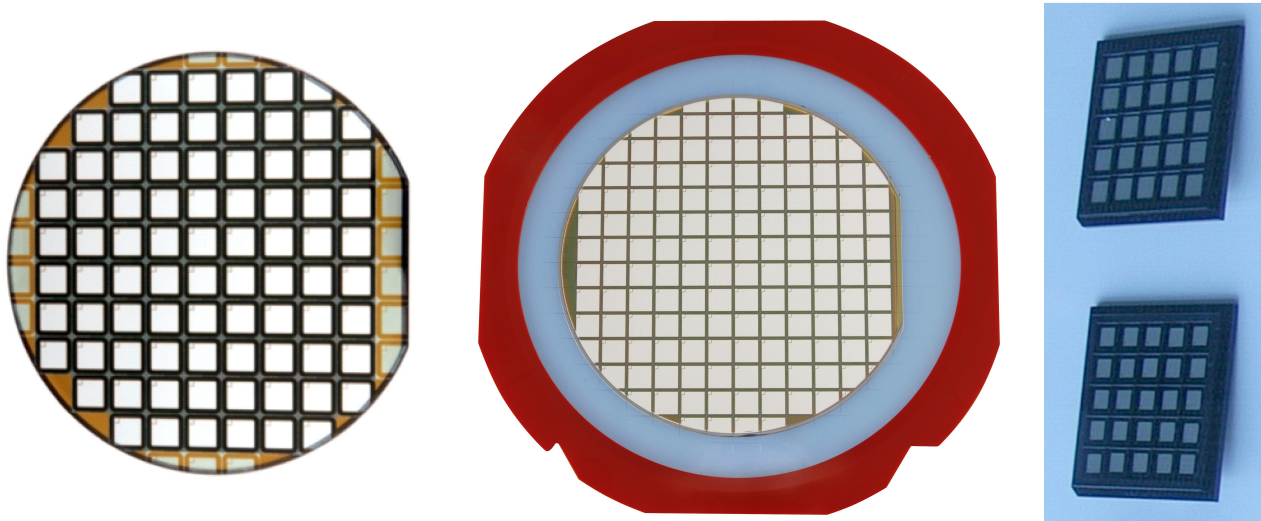

Figure 1: From left to right: un-sawn wafer (type 76), sawn wafer die on frame (type 86), picked dies in waffle-packs (type 12)

Note that dies rated above 1700 V can only be supplied in waffle packs.

1.4 Electro-static discharge sensitivity

The IGBT is an electrostatic sensitive device and must be handled properly to avoid damage from electrostatic discharge (ESD). Therefore please observe the international standard IEC 60747-1 chapter IX.

2 Data sheet users guide

This section is a detailed guide to the proper understanding of a die data sheet. Parameters and ratings will be defined and illustrated with figures, where appropriate. For explanation purposes, data and diagrams associated with IGBT type 5SMY 12K1201 and diode 5SLX 12M1711 have been used but because the other IGBTs and other diode dies have similar data sheets, this guide is applicable to all IGBT and diode dies.

The data sheets distinguish between maximum rated values and characteristic values. Maximum values indicate limits beyond which damage may occur to the device. Characteristic values are parameters defined under typical application conditions.

ABB reserves the right to change data sheets without notice. Therefore, please visit our internet web site at www.abb.com/semiconductors, for the latest version.

2.1 Key parameters and features

V_{CE}	$=$	1200 V	IGBT-Die
I_C	$=$	100 A	
			5SMY 12K1201
Die size: 11.9 x 11.2 mm			

Doc. No. 5SYA1635-01 Sep 06

- **Ultra low loss thin IGBT die**
- **Highly rugged SPT⁺ design**
- **Large bondable emitter area**

The key features give the type, the basic voltage and current rating and the size of the die. They are followed by a short description of the technologies used and the main features of these technologies.

2.2 Maximum rated values IGBT

Maximum rated values ¹⁾

Parameter	Symbol	Conditions	min	max	Unit
Collector-emitter voltage	V_{CES}	$V_{GE} = 0 \text{ V}, T_{vj} \geq 25 \text{ °C}$		1200	V
DC collector current	I_C			100	A
Peak collector current	I_{CM}	Limited by T_{vjmax}		200	A
Gate-emitter voltage	V_{GES}		-20	20	V
IGBT short circuit SOA	t_{psc}	$V_{CC} = 900 \text{ V}, V_{CEM} \leq 1200 \text{ V}$ $V_{GE} \leq 15 \text{ V}, T_{vj} \leq 125 \text{ °C}$		10	μs
Junction temperature	T_{vj}		-40	150	$^{\circ}\text{C}$

¹⁾ Maximum rated values indicate limits beyond which damage to the device may occur per IEC 60747 - 9

V_{CES} : *Collector-emitter voltage.* The maximum collector-emitter voltage that may not be exceeded under any conditions. Applying voltages to the die in excess of this limit, even of short duration, can lead to device failure.

The collector-emitter blocking voltage has a temperature dependency. All ABB devices have been designed to have full blocking voltage within the specified temperature range.

Applying high DC voltages to a semiconductor will increase the failure rates due to cosmic radiation. For this reason, the operating DC voltage is much lower than the peak repetitive voltage V_{CES} defined above. This is explained and specified on module level in Application Note 5SYA2042. For design voltage recommendations see document 5SYA2051.

I_C : *DC collector current.* The nominal DC current.

I_{CM} : *Peak collector current*. The maximum peak current that the IGBT can switch within specified limits. Exceeding this limit may lead to turn-off failures and (depending on pulse duration) also to over-heating of the device.

V_{GES} : *Gate-emitter voltage*. The absolute maximum allowable voltage between gate and emitter under any conditions. Exceeding the specified limits may lead to degradation of the gate oxide, ultimately leading to device failure.

t_{psc} : *IGBT Short Circuit SOA*. The maximum duration of a short-circuit current pulse through the IGBT at the specified conditions. Exceeding this duration will over-heat the device and cause a failure. t_{psc} determines the limit for the time allowed for possible fault detection and turn-off via the gate unit.

T_{vj} : *Junction temperature*. The IGBT chips are capable of operating at temperatures up to the specified limit.

2.3 Maximum rated values Diode

Maximum rated values ¹⁾

Parameter	Symbol	Conditions	min	max	Unit
Repetitive peak reverse voltage	V_{RRM}			1700	V
Continuous forward current	I_F			200	A
Repetitive peak forward current	I_{FRM}	Limited by T_{vjmax}		400	A
Junction temperature	T_{vj}		-40	125	°C

¹⁾ Maximum rated values indicate limits beyond which damage to the device may occur per IEC 60747 - 2

V_{RRM} : *Repetitive peak reverse voltage*. Maximum voltage that the device can block repetitively.

The anode-cathode reverse voltage has a temperature dependency. All ABB devices have been designed to have full blocking voltage within the specified temperature range.

Applying high DC voltages to a semiconductor will increase the failure rates due to cosmic radiation. For this reason, the operating DC voltage is much lower than the peak repetitive voltage V_{RRM} defined above. This is explained and specified on module level in Application Note 5SYA2042. For design voltage recommendations see Application Note 5SYA2051.

I_F : *Continuous forward current*. The nominal DC current.

I_{FRM} : *Repetitive peak forward current*. The maximum peak current that the diode can conduct within the specified limits. Exceeding this limit may lead to turn-off failures and (depending on pulse duration) over-heating of the device.

T_{vj} : *Junction temperature*. The diode chips are capable of operating at temperatures up to the specified limit.

2.4 IGBT characteristic values

The characteristic values are divided into static and dynamic values.

IGBT characteristic values ²⁾

Parameter	Symbol	Conditions	min	typ	max	Unit
Collector (-emitter) breakdown voltage	$V_{(BR)CES}$	$V_{GE} = 0 \text{ V}, I_C = 1 \text{ mA}, T_{vj} = 25 \text{ }^\circ\text{C}$	1200			V
Collector-emitter saturation voltage	$V_{CE \text{ sat}}$	$I_C = 100 \text{ A}, V_{GE} = 15 \text{ V}$	$T_{vj} = 25 \text{ }^\circ\text{C}$	1.8		V
			$T_{vj} = 125 \text{ }^\circ\text{C}$	2.0		V
Collector cut-off current	I_{CES}	$V_{CE} = 1200 \text{ V}, V_{GE} = 0 \text{ V}$	$T_{vj} = 25 \text{ }^\circ\text{C}$		100	μA
			$T_{vj} = 125 \text{ }^\circ\text{C}$	400		μA
Gate leakage current	I_{GES}	$V_{CE} = 0 \text{ V}, V_{GE} = \pm 20 \text{ V}, T_{vj} = 125 \text{ }^\circ\text{C}$	-200		200	nA
Gate-emitter threshold voltage	$V_{GE(TO)}$	$I_C = 4 \text{ mA}, V_{CE} = V_{GE}, T_{vj} = 25 \text{ }^\circ\text{C}$	5	6.2	7	V
Gate charge	Q_{ge}	$I_C = 100 \text{ A}, V_{CE} = 600 \text{ V}, V_{GE} = -15 \text{ ..} 15 \text{ V}$		1050		nC
Input capacitance	C_{ies}	$V_{CE} = 25 \text{ V}, V_{GE} = 0 \text{ V}, f = 1 \text{ MHz}, T_{vj} = 25 \text{ }^\circ\text{C}$		7.43		nF
Output capacitance	C_{oes}			0.52		
Reverse transfer capacitance	C_{res}			0.34		
Internal gate resistance	R_{Gint}			2		Ω

$V_{(BR)CES}$: *Collector (-emitter) breakdown voltage.* The minimum voltage that the device will block in the forward direction at the specified conditions.

V_{CEsat} : *Collector-emitter saturation voltage.* The collector-emitter voltage at the specified conditions. This value can depend on the pattern of the bonding wires.

I_{CES} : *Collector cut-off current.* The collector current at the specified collector-emitter voltage with the gate short-circuited to the emitter.

I_{GES} : *Gate leakage current.* The gate leakage current at the specified gate-emitter voltage with the collector short-circuited to the emitter.

$V_{GE(TO)}$: *Gate-Emitter threshold voltage.* The gate-emitter voltage at which the collector current attains the specified value.

Q_{ge} : *Gate charge.* The charge required to raise the gate voltage from the specified minimum to the specified maximum value at the specified conditions.

C_{ies} : *Input capacitance.* The capacitance between the gate and the emitter at given conditions.

C_{oes} : *Output capacitance.* The capacitance between the collector and the emitter at given conditions.

C_{res} : *Reverse transfer capacitance.* The capacitance between the collector and the gate at given conditions.

R_{Gint} : *Internal gate resistor.* The value of the built-in resistor in the gate.

Turn-on delay time	$t_{d(on)}$	$V_{CC} = 600 \text{ V}, I_C = 100 \text{ A}, R_G = 10 \Omega, V_{GE} = \pm 15 \text{ V},$	$T_{vj} = 25 \text{ }^\circ\text{C}$	125	ns
			$T_{vj} = 125 \text{ }^\circ\text{C}$	135	
Rise time	t_r	$L_\sigma = 60 \text{ nH},$ inductive load	$T_{vj} = 25 \text{ }^\circ\text{C}$	60	ns
			$T_{vj} = 125 \text{ }^\circ\text{C}$	60	
Turn-off delay time	$t_{d(off)}$	$V_{CC} = 600 \text{ V}, I_C = 100 \text{ A}, R_G = 10 \Omega, V_{GE} = \pm 15 \text{ V},$	$T_{vj} = 25 \text{ }^\circ\text{C}$	420	ns
			$T_{vj} = 125 \text{ }^\circ\text{C}$	490	
Fall time	t_f	$L_\sigma = 60 \text{ nH},$ inductive load	$T_{vj} = 25 \text{ }^\circ\text{C}$	60	ns
			$T_{vj} = 125 \text{ }^\circ\text{C}$	75	
Turn-on switching energy	E_{on}	$V_{CC} = 600 \text{ V}, I_C = 100 \text{ A}, V_{GE} = \pm 15 \text{ V}, R_G = 10 \Omega, L_\sigma = 60 \text{ nH},$ inductive load, FWD: 5SLX 12H1200	$T_{vj} = 25 \text{ }^\circ\text{C}$	8.6	mJ
			$T_{vj} = 125 \text{ }^\circ\text{C}$	12.4	
Turn-off switching energy	E_{off}	$V_{CC} = 600 \text{ V}, I_C = 100 \text{ A}, V_{GE} = \pm 15 \text{ V}, R_G = 10 \Omega, L_\sigma = 60 \text{ nH},$ inductive load	$T_{vj} = 25 \text{ }^\circ\text{C}$	6.8	mJ
			$T_{vj} = 125 \text{ }^\circ\text{C}$	10.8	
Short circuit current	I_{SC}	$t_{psc} \leq 10 \mu\text{s}, V_{GE} = 15 \text{ V}, T_{vj} = 125 \text{ }^\circ\text{C}, V_{CC} = 900 \text{ V}, V_{CEM} \leq 1200 \text{ V}$		470	A

²⁾ Characteristic values according to IEC 60747 - 9

All switching parameters are defined in a phase-leg connection using an auxiliary component (AUX) of the same family/rating as the device under test (DUT), see Figure 2. For the definitions of the different switching parameters, see Figure 3 and Figure 4. All switching parameters in ABB data sheets are specified for an inductive load.

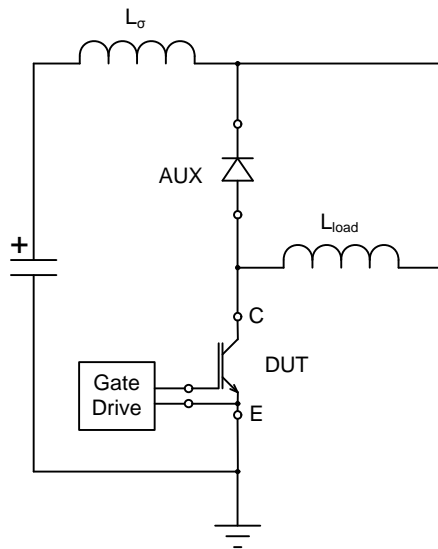

Figure 2: Electrical circuit for testing of the dynamic performance of the IGBT

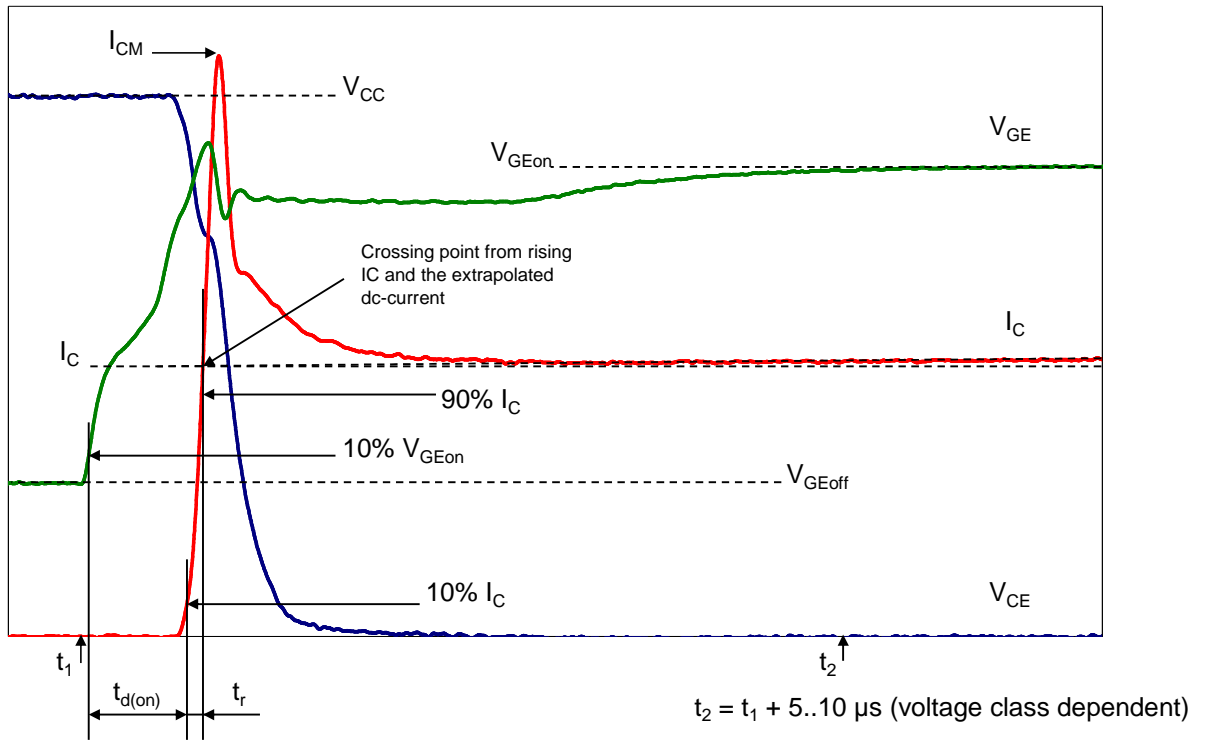

Figure 3: Definitions of the turn-on parameters for the IGBT

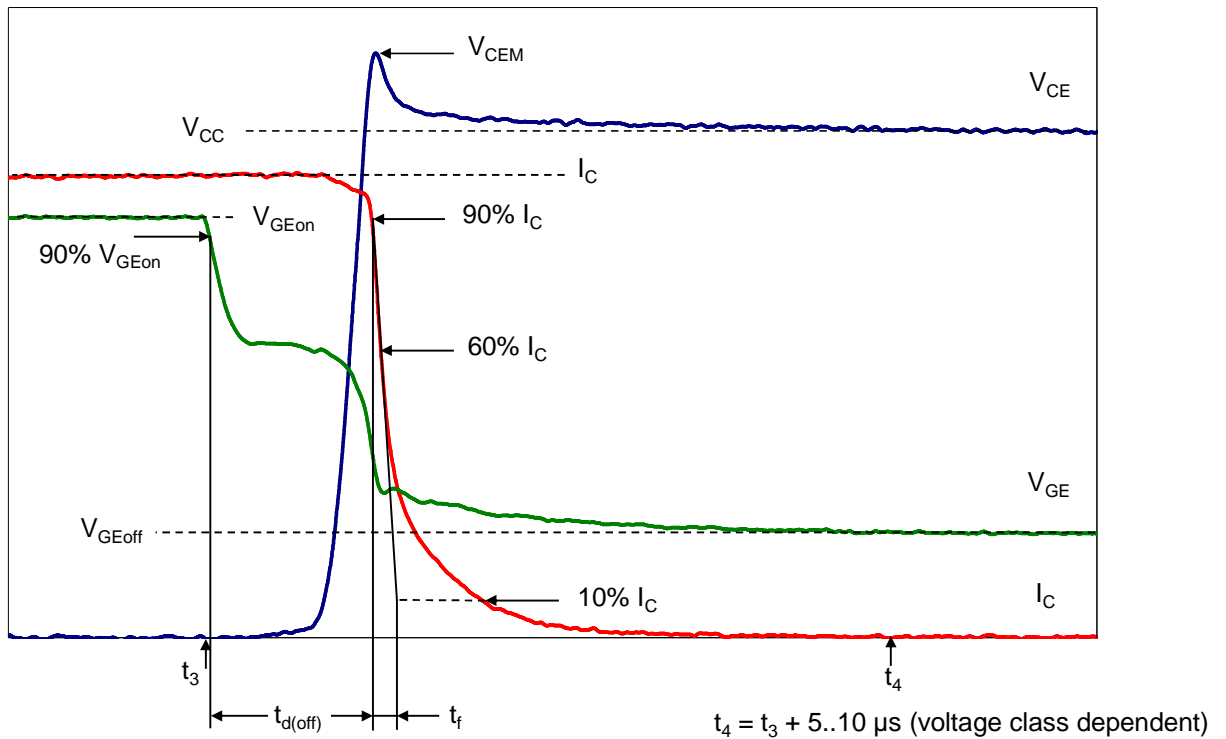

Figure 4: Definitions of turn-off parameters for IGBTs

$t_{d(on)}$: *Turn-on delay time.* The turn-on delay time is defined as the time between the instant when the gate voltage has reached 10 % of its final value and the instant when the collector current has reached 10 % of its final value.

t_r : *Rise time.* The rise time is defined as the time between instants when the collector current has risen from 10 % to 90 % of its final value.

The total turn-on time t_{on} is the sum of $t_{d(on)}$ and t_r .

$t_{d(off)}$: *Turn-off delay time.* The turn-off delay time is defined as the time between the instant when the gate voltage has dropped to 90 % of its initial value and the instant when the collector current has dropped to 90 % of its initial value.

t_f : *Fall time.* The fall time is defined as the time between instants when the collector current has dropped from 90 % to 10 % of its initial value along an extrapolated straight line drawn between the instants when the current has reached 90 % and 60 % of its initial value.

The total turn-off time t_{off} is the sum of $t_{d(off)}$ and t_f .

E_{on} : *Turn-on switching energy.* The energy dissipated during a single turn-on event. It is the integration of the product of collector current and collector-emitter voltage from t_1 to t_2 (see Figure 3) as expressed by Equation 1. Note that the value depends on the used free-wheel diode having the same temperature as the IGBT. The use of other diodes may lead to other values.

$$E_{on} = \int_{t_1}^{t_2} (i_C(t) \cdot v_{CE}(t)) dt$$

Equation 1

E_{off} : *Turn-off switching energy.* The energy dissipated during a single turn-off event. It is the integration of the product of the collector current and the collector-emitter voltage from t_3 to t_4 (see Figure 4) as expressed by Equation 2.

$$E_{off} = \int_{t_3}^{t_4} (i_C(t) \cdot v_{CE}(t)) dt$$

Equation 2

I_{sc} : *Short circuit current.* The self-limited current reached in de-saturation when the device is turned on into a short circuit at the specified conditions. Typical waveforms during such an event are shown in Figure 6. The value shown in the data sheet is the average current during the middle 25 % of the current pulse.

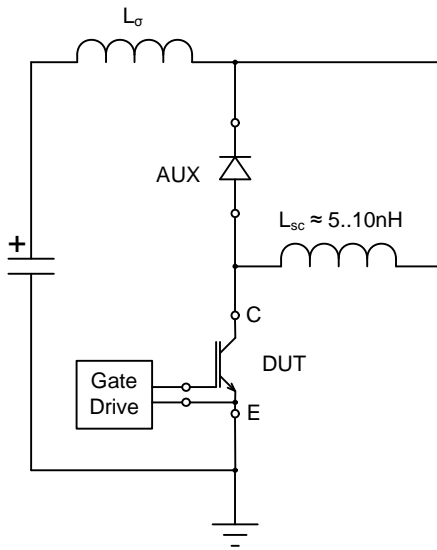

Figure 5: Electrical circuit for testing of the Short-Circuit performance of the IGBT

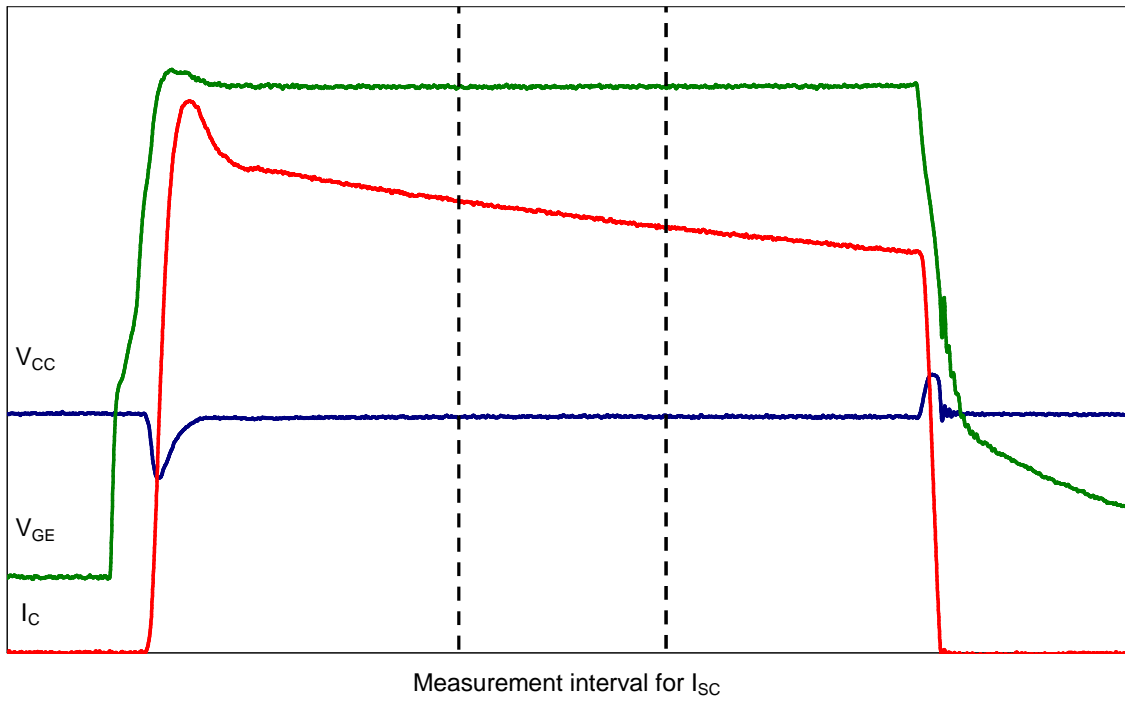

Figure 6: Typical waveforms for Short-Circuit

2.5 Diode characteristic values

Diode characteristic values ²⁾

Parameter	Symbol	Conditions	min	typ	max	Unit	
Continuous forward voltage	V_F	$I_F = 200 \text{ A}$	$T_{vj} = 25 \text{ }^\circ\text{C}$	1.4	1.65	2.0	V
			$T_{vj} = 125 \text{ }^\circ\text{C}$		1.7		V
Continuous reverse current	I_R	$V_R = 1700 \text{ V}$	$T_{vj} = 25 \text{ }^\circ\text{C}$			100	μA
			$T_{vj} = 125 \text{ }^\circ\text{C}$		4		mA
Peak reverse recovery current	I_{rr}	$I_F = 200 \text{ A},$ $V_R = 900 \text{ V},$ $di/dt = 1000 \text{ A}/\mu\text{s},$ $L_\sigma = 800 \text{ nH},$ Inductive load, Switch: 2x 5SMX12M1701	$T_{vj} = 25 \text{ }^\circ\text{C}$		150		A
			$T_{vj} = 125 \text{ }^\circ\text{C}$		192		A
Recovered charge	Q_{rr}	$I_F = 200 \text{ A},$ $V_R = 900 \text{ V},$ $di/dt = 1000 \text{ A}/\mu\text{s},$ $L_\sigma = 800 \text{ nH},$ Inductive load, Switch: 2x 5SMX12M1701	$T_{vj} = 25 \text{ }^\circ\text{C}$		59		μC
			$T_{vj} = 125 \text{ }^\circ\text{C}$		98		μC
Reverse recovery time	t_{rr}	$I_F = 200 \text{ A},$ $V_R = 900 \text{ V},$ $di/dt = 1000 \text{ A}/\mu\text{s},$ $L_\sigma = 800 \text{ nH},$ Inductive load, Switch: 2x 5SMX12M1701	$T_{vj} = 25 \text{ }^\circ\text{C}$		520		ns
			$T_{vj} = 125 \text{ }^\circ\text{C}$		700		ns
Reverse recovery energy	E_{rec}	$I_F = 200 \text{ A},$ $V_R = 900 \text{ V},$ $di/dt = 1000 \text{ A}/\mu\text{s},$ $L_\sigma = 800 \text{ nH},$ Inductive load, Switch: 2x 5SMX12M1701	$T_{vj} = 25 \text{ }^\circ\text{C}$		46		mJ
			$T_{vj} = 125 \text{ }^\circ\text{C}$		75		mJ

²⁾ Characteristic values according to IEC 60747 - 2

All switching parameters are defined in a phase leg connection using the specified IGBT-dies as auxiliary components (AUX) having the same temperature as the Diode, see Figure 7. For the definitions of the different switching parameters see Figure 8. All switching parameters in the ABB data sheet are specified for inductive load.

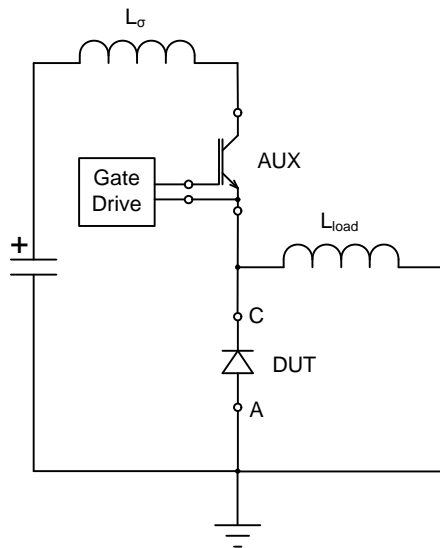

Figure 7: Test circuit for the dynamic performance of the Diode

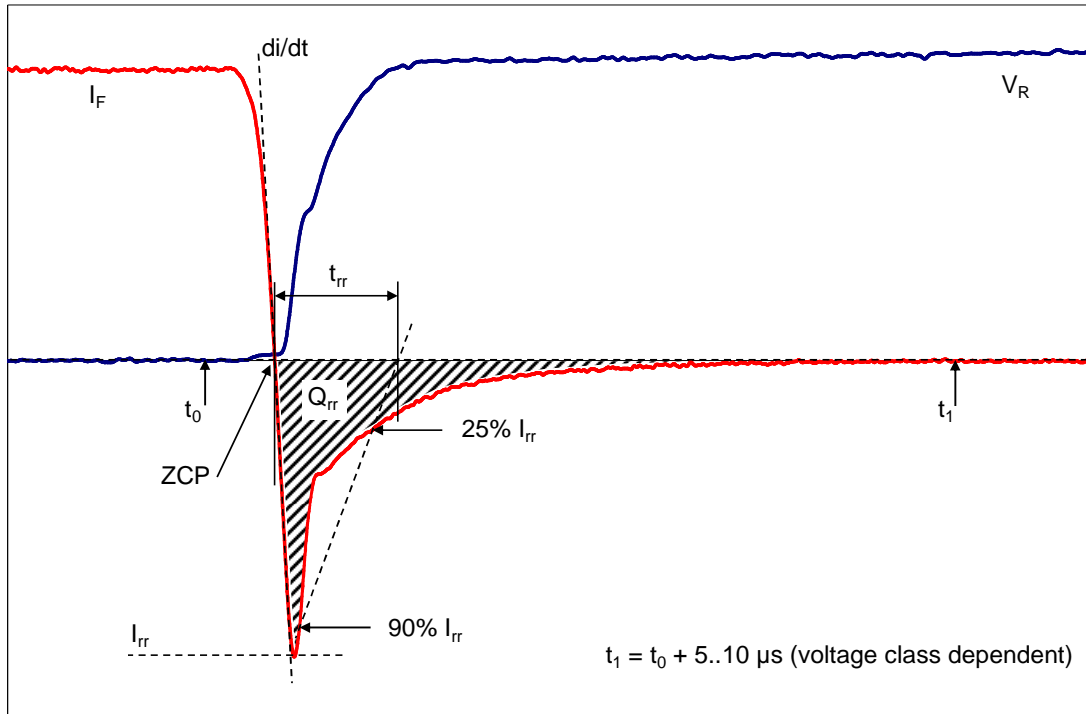

Figure 8: Definitions for the turn-off parameters for the diode

V_F : *Forward voltage.* The anode-cathode on-state voltage of the diode at the specified conditions. This value depends on the pattern of the bonding wires.

I_R : *Reverse current.* The leakage current at the specified conditions.

I_{rr} : *Reverse recovery current.* The peak value of the reverse current during commutation at the specified conditions.

Q_{rr} : *Reverse recovery charge.* The integral over time of the reverse current during commutation at the specified conditions starting at the zero-crossing of the current and ending when the reverse current has decayed to zero after the tail-current phase.

t_{rr} : *Reverse recovery time.* The commutation time of the diode at the specified conditions. It is measured between the current zero-crossing and the zero-crossing of the extrapolation between 90 and 25% of the reverse current peak I_{rr} (on the falling flank).

E_{rec} : *Reverse recovery energy.* The energy dissipated during a single reverse recovery event. It is the integration of the product of the reverse current and voltage from t_0 to t_1 (see Figure 8) as expressed by Equation 3.

$$E_{rec} = \int_{t_0}^{t_1} (i_R(t) \cdot v_R(t)) dt$$

Equation 3

di/dt : The current rate-of-change of the falling flank is calculated as the slope of the linear fit over 100ns around the zero crossing point (ZCP) on the falling flank.

2.6 Mechanical properties

Mechanical properties

Parameter				Unit
Dimensions	Overall die	L x W	11.9 x 11.2	mm
	exposed front metal	L x W (except gate pad)	10.4 x 9.7	mm
	gate pad	L x W	1.2 x 1.22	mm
	thickness		130 ± 20	µm
Metallization ³⁾	front (E)	AISi1	4	µm
	back (C)	Al / Ti / Ni / Ag	1.2	µm

³⁾ For assembly instructions refer to : IGBT and Diode chips from ABB Switzerland Ltd, Semiconductors, Doc. No. 5SYA 2033.

Overall dimension L x W: The overall dimension of the die. Tolerances are found in the outline drawing.

Exposed front metal L x W: The size of the front (emitter for IGBT and anode for diode) metallization available for bonding.

Gate pad L x W: The size of the gate pad metallization on the IGBT-die available for bonding. Tolerances are found in the outline drawing.

Thickness: The thickness of the die.

Front metallization: Composition and thickness of the front (emitter for IGBT and anode for diode) metallization.

Back metallization: Composition and thickness of the back (collector for IGBT and cathode for diode) metallization.

2.7 Outline drawing

Outline drawing

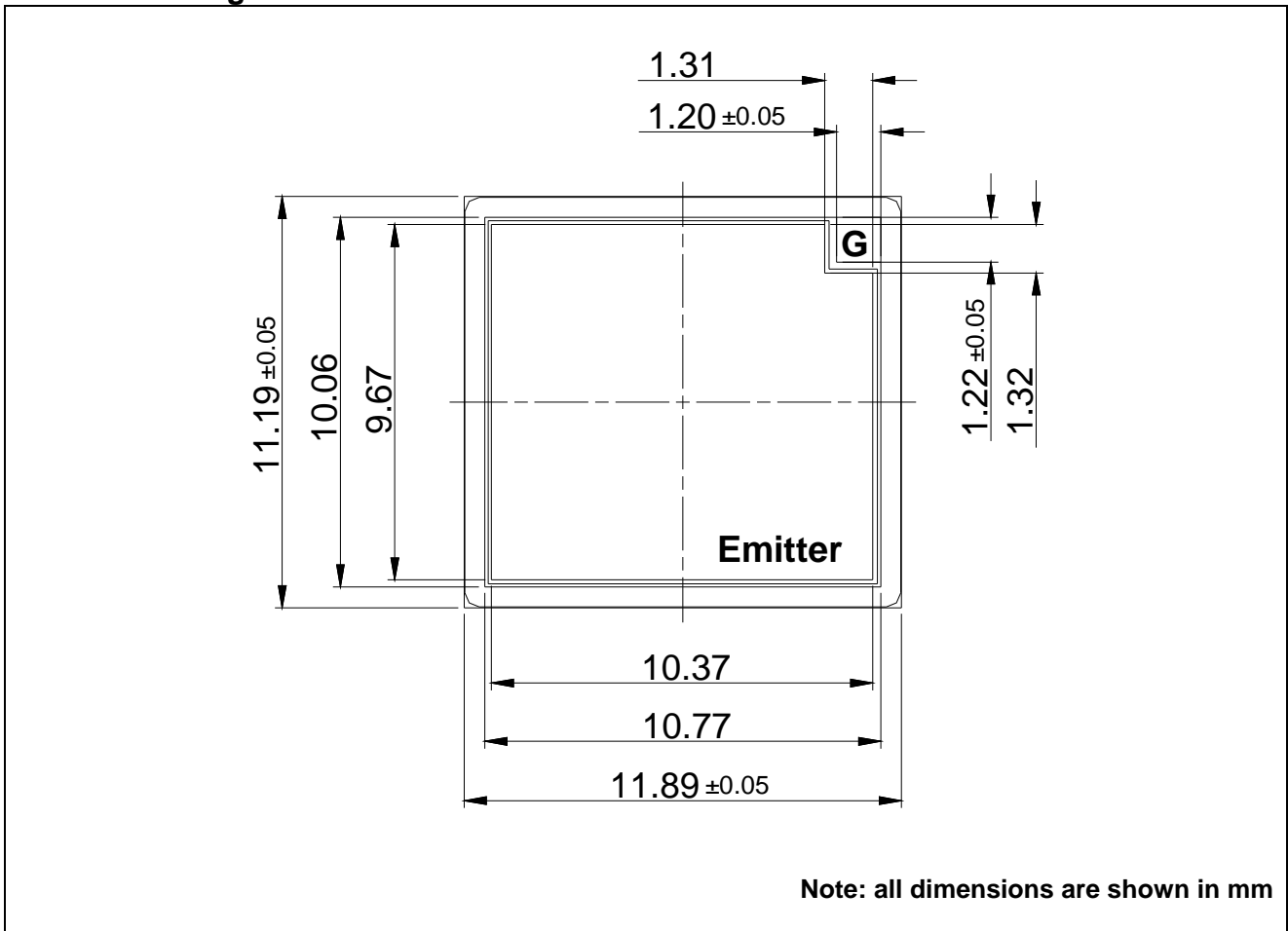

The outline drawing shows the dimensions of the die with tolerances. All dimensions for the ABB-products are in mm.

2.8 Diagrams IGBT

In addition to the table data a number of diagrams are included showing the most important dependencies of the main parameters.

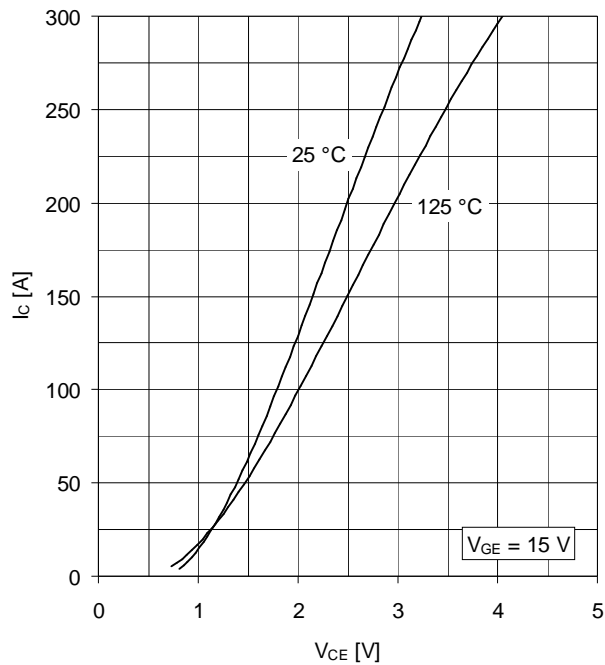

Figure 9: Typical on-state characteristic

The on-state voltage for the IGBT is given as a function of the collector current at $V_{GE} = 15$ V for junction temperatures 25 °C and 125 °C, respectively. The characteristics are typical.

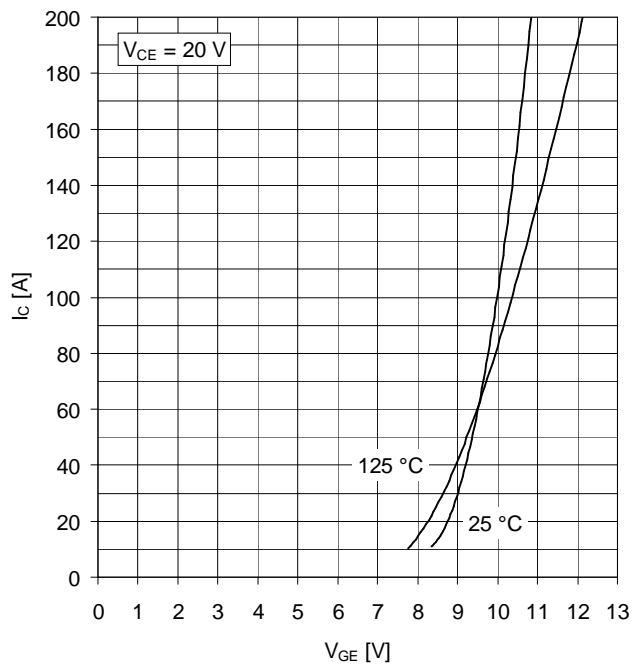

Figure 10: Typical transfer characteristic

The typical transfer characteristic shows the collector current as a function of the gate-emitter voltage for junction temperatures 25 °C and 125 °C, respectively.

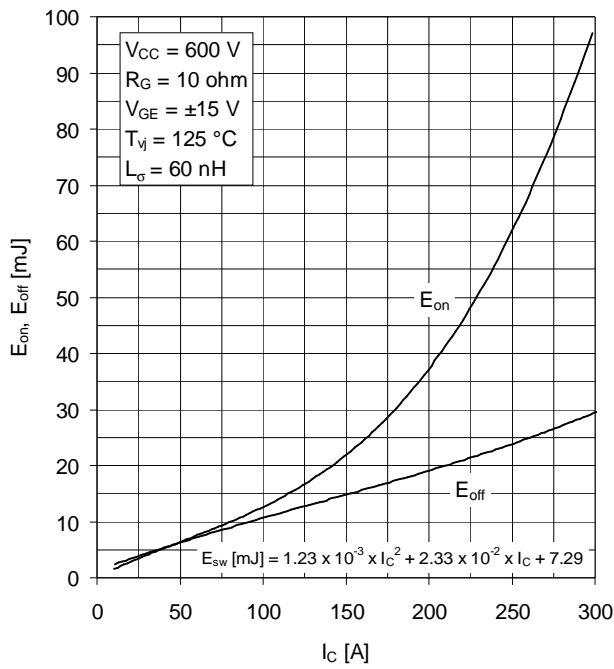

Figure 11: Typical switching energies per pulse vs. collector current

Typical switching energies for the IGBT as a function of the collector current at the specified conditions using the circuit of Figure 2. Included is a fitted equation for $E_{sw} = E_{on} + E_{off}$ as a function of collector current.

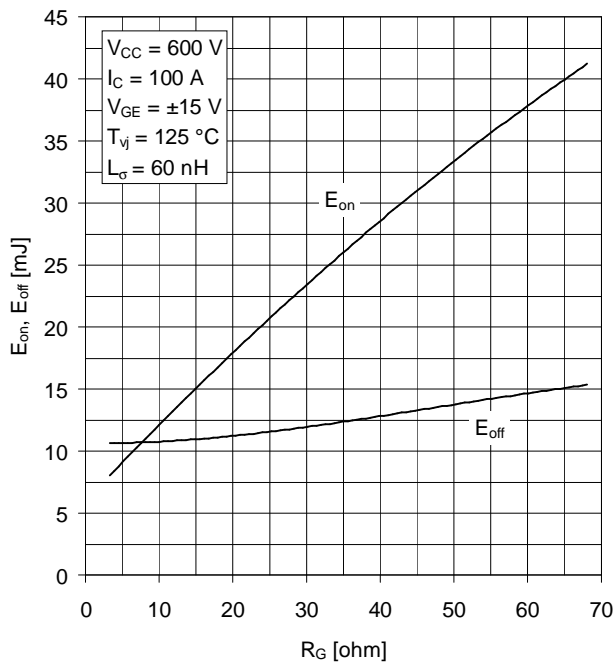

Figure 12: Typical switching energies per pulse vs. gate resistor

Typical switching energies for the IGBT as a function of the gate resistor at the specified conditions using the circuit in Figure 2.

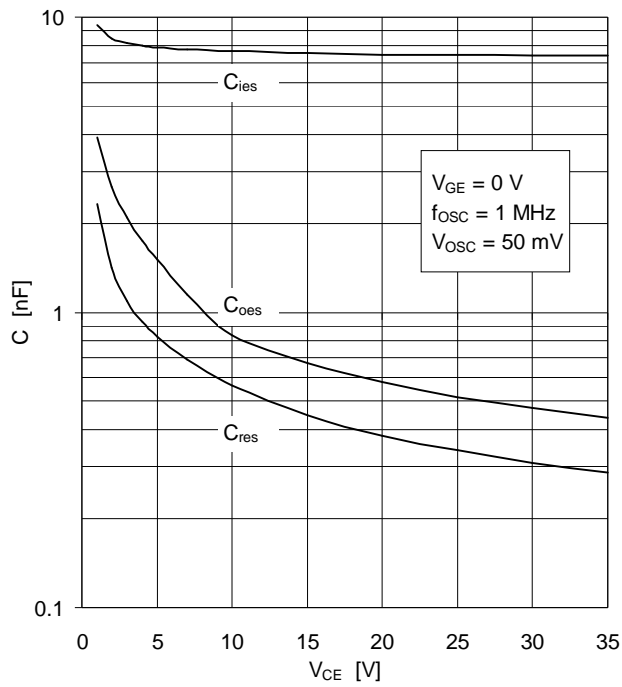

Figure 13: Typical capacitances vs. collector-emitter voltage

Typical input, output and transfer capacitances as a function of the collector-emitter voltage at the specified conditions.

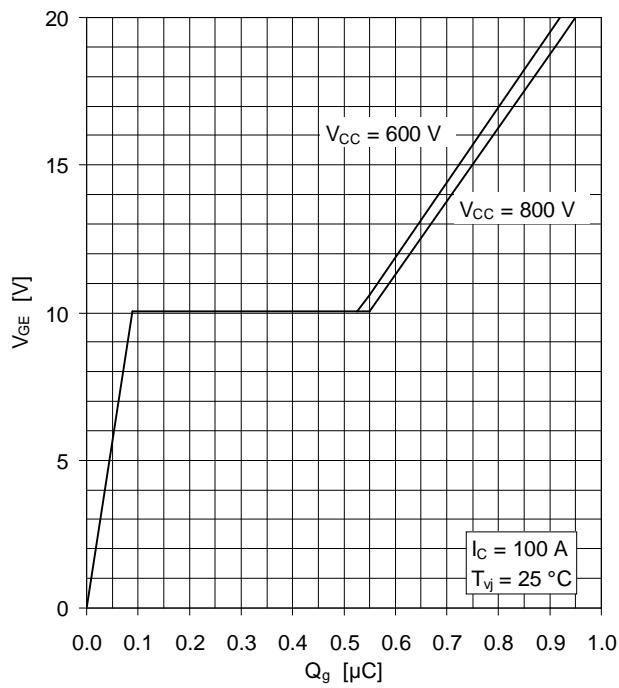

Figure 14: Typical gate charge characteristics

Typical gate voltage as a function of the gate charge at collector-emitter voltages 600 V and 800 V, respectively.

2.9 Diagrams Diode

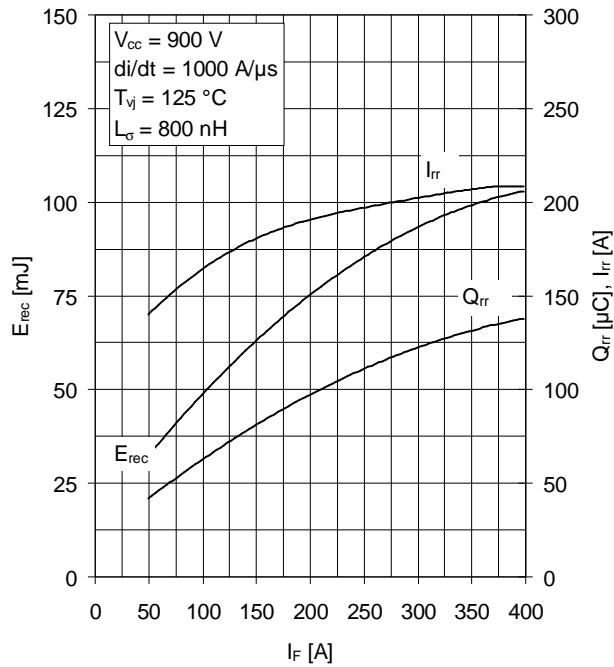

Figure 15: Typical reverse recovery characteristics vs. forward current

Typical values of turn-off parameters for the diode as a function of the forward current at the specified conditions using the circuit of Figure 7.

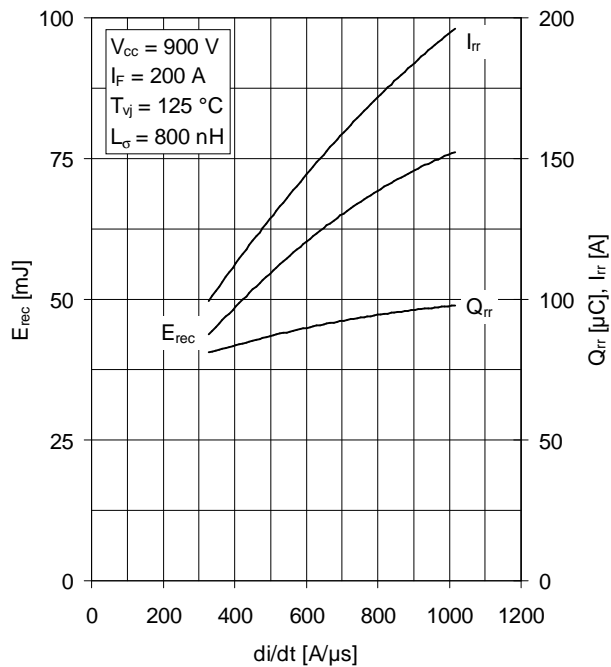

Figure 16: Typical reverse recovery characteristics vs. di/dt

Typical values of turn-off parameters for the diode as a function of the rate of decline of the forward current at the specified conditions using the circuit of Figure 7.

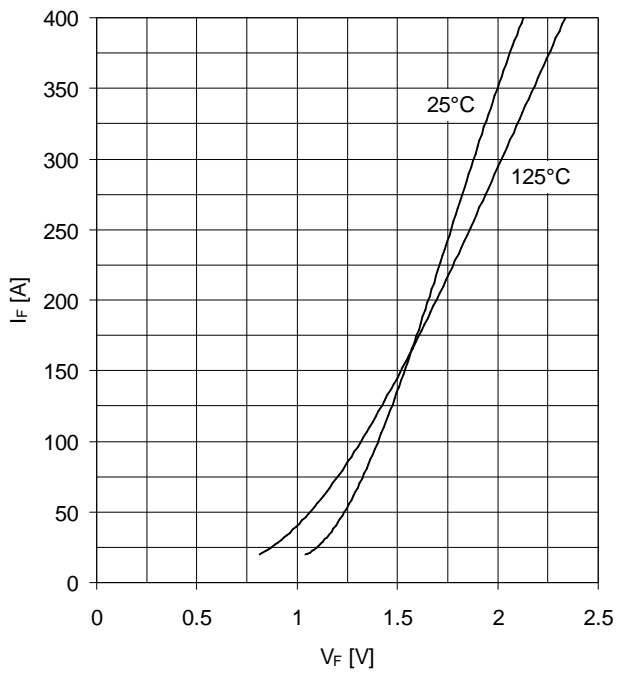

Figure 17: Typical diode forward characteristic

The typical on-state voltage for the diode is given as a function of the forward current for junction temperatures 25 °C and 125 °C, respectively. The characteristics are typical (including bond wires).

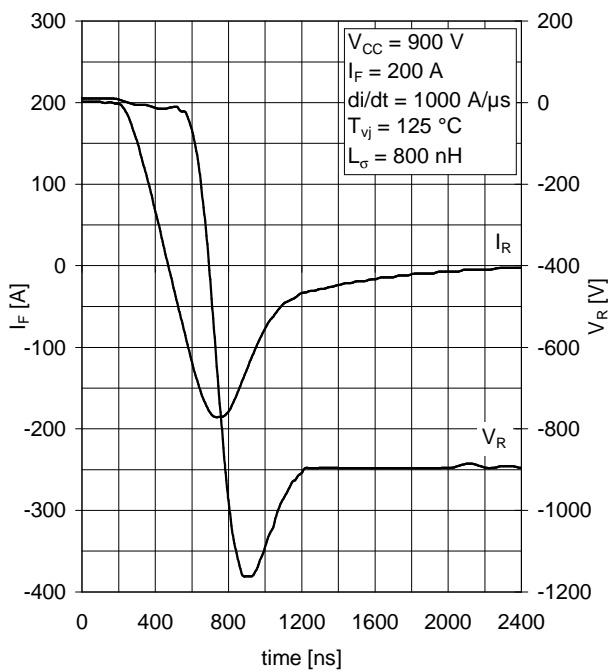

Figure 18: Typical diode reverse recovery behaviour

Typical turn-off behaviour of the diode at the specified conditions.

3 Testing, Shipment, Storage and Handling of IGBT and Diode dies

Chips are 100% probed for static electrical parameters prior to shipment. The parameters which cannot be measured during wafer testing (such as dynamic characteristics) are guaranteed by the design-qualification tests and are monitored on a sample basis. Additionally, a thorough visual inspection is performed at the wafer-labelling stage just prior to packing. Different shipment and packaging options are available: chips can be supplied in industry-standard waffle-pack trays as sawn and picked dies. Alternatively wafers can be supplied un-sawn or sawn on foil (with ring frame). In the case of wafer shipments, rejected dies are inked during probe testing as part of the test process.

Note that dies rated above 1700 V can only be supplied in waffle packs.

Chip mounting requires a high level of cleanliness and chips must be handled with extreme caution. All chips should be manipulated and placed using rubber vacuum pencils. It is strongly recommended that chips be utilised immediately after unpacking or be stored in a dry nitrogen atmosphere at temperatures between 15 °C and 35 °C. IGBT chips, being MOS-controlled devices, are electro-statically sensitive and should be handled according to standard ESD procedures with ESD protected equipment.

3.1 Testing at elevated temperature

Products shipped as wafer die (type 76 or 86) cannot be tested at elevated temperatures. Maximum values for leakage currents are therefore to be understood on the statistical base of a regular internal quality monitoring program on (sawn) die populations.

In case a 100% control on the leakage current is required at higher temperature levels (e.g. 125 °C) the user shall:

- Perform a 100% outgoing inspection at the required temperature level.
- Purchase the required chips as "Picked Die".

4 Assembly Recommendations

4.1 Die Attachment

ABB chips have a backside metallization (collector or cathode) consisting of four metallic layers (Al/Ti/Ni/Ag) suitable for soldering. Soldering temperatures should not exceed a maximum of 350 °C or a plateau temperature of 340 °C for more than 5 minutes. Measures should be taken to avoid chip misalignment as a result of floating during the soldering process.

4.2 Wire bonding

The chip front-side metallization (emitter or anode) for dies designed for contact through wire bonding is finished in aluminium-silicon suitable for standard ultrasonic wire bonding processes. Aluminium (99.999%) wire bonds are normally used with the thickness and number of wire bonds mainly determined by the required current rating. During the wire-bonding process, it is important to protect against damage to the chips due to wire-bond misalignment, excessive pressure or resonance of the substrate which could damage the gate oxide layer or termination areas.

4.3 Surface coverage

Please be aware that the dies cannot be operated without further protection against voltage flash-overs. Typically this protection is provided by encapsulation with silicone gel.

For detailed information please contact your manufacturer or distributor of silicone gel.

5 Additional notes

5.1 References

- 1) IEC 60747-1..9 "Semiconductor devices"
- 2) 5SYA2042 "Failure rates of HiPak modules due to cosmic ray"
- 3) 5SYA2045 "Thermal run-away during blocking"
- 4) 5SYA2051 "Voltage ratings of high power semiconductors"
- 5) 5SYA2053 "Applying IGBTs"
- 6) 5SYA2058 "Surge currents for IGBT diodes"

The application notes, references 2 to 5, are available at www.abb.com/semiconductors.

5.2 Application support

For further information please contact:

Customer support

Jörg Berner

Phone +41 58 586 16 35, fax +41 58 5861 306

e-mail joerg.berner@ch.abb.com

Address:

ABB Switzerland Ltd

Semiconductors

Fabrikstrasse 3

CH-5600 Lenzburg

Switzerland

E-Mail abbsem@ch.abb.com

Internet www.abb.com/semiconductors

Data sheets for the devices and your nearest sales office can be found on the ABB Switzerland Ltd, Semiconductors internet web site:

<http://www.abb.com/semiconductors>