

Switch 560NMS24



Application

The RTU component 560NMS24 is a managed plug and play Layer2-switch providing four Fast Ethernet auto-negotiating RJ45-ports with auto MDI/X (Automatic Crossover Detection and Correction) and two 2-wire SDSL-ports for use with private copper cables. It can be used with rack types 560MPR01, 560 MPR03, 23TP21/22, 560SFR02 and 23ET23/24. The switch is intended for distributing Ethernet within a station through the RJ45-ports. The SDSL ports can be used for interconnecting stations with a maximum distance of 20 km (copper cable with diameter of 0.8 mm). Longer distances can be achieved by cascading multiple 560NMS24. The switch is able to provide redundant topologies by the (Rapid) Spanning Tree Protocol.

For documentation purposes, the Ethernet ports are labeled from 1 to 4. The SDSL ports are connected through the backplane. There is no specific uplink port. All ports are equal in function. Link and speed status of each Ethernet and SDSL port are displayed by status indicators (refer to Connectors and Indicators).

The switch learns Ethernet addresses by analyzing received frames and stores them in a lookup-table (max. 2048 entries), which is used to forward frames only to the correct port.

If it is broad- or multicast or if the target address is not found in the lookup-table, a received frame is forwarded to all ports except the receiving one. If an entry in the lookup-table is not refreshed by an incoming frame with the specific source address, it is aged out within a maximum of 304 seconds (by default, value is configurable).

Regarding IEEE 802.1Q VLAN frames, the switch can be configured to VLAN or transparent mode. In transparent mode the switch will never change any frame or TAG of a frame; in VLAN mode it can be configured to support several applications like trunk or access ports.

Quality-of-Service is supported by the switch if an IEEE 802.1p compliant frame format is used. The switch can separate frames into up to four queues, which can be configured to priority based or weighted-fair queuing.

The 560NMS24 uses a power supply voltage of 5 V that can be set to the internal RTU supply or external supply via a Jumper.

The component itself, the Ethernet ports as well as the SDSL connections are hot-plug capable.

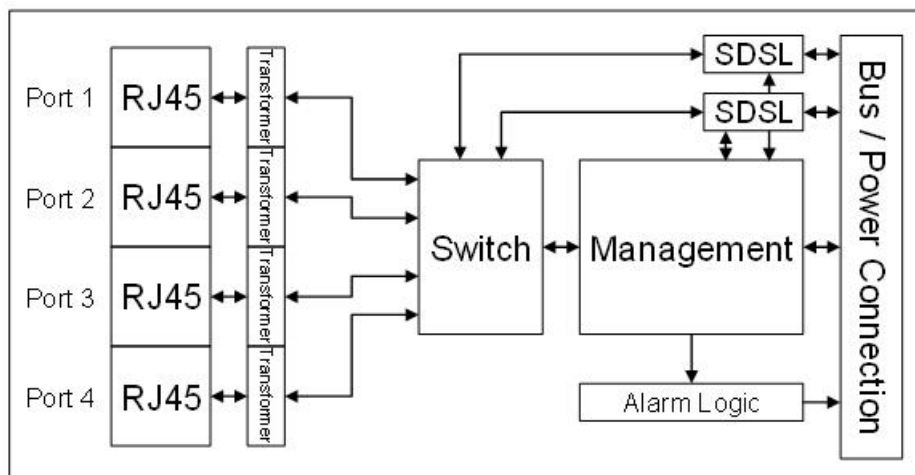

Fig. 1: Block diagram of 560NMS24

RTU560

Data Sheet Switch 560NMS24

Connectors & Indicators

The 560NMS24 switch consists of four equal RJ45 Ethernet ports, two identical SDSL transceivers and an RS-232 interface for configuration and tunneling of serial data. Each RJ45 port can be connected with a Cat. 3 (for 10 Mbps) or Cat. 5 (for 100 Mbps) Ethernet cable with a maximum length of 100 meters. The cable should only be used for in-house connections. Since Auto MDI/X is supported by the 560NMS24 switch for the RJ45 ports, there is no need for crossover cables.

The SDSL interfaces can be connected to 2-wire customer-owned copper lines. The maximum bridgeable distance is 20 km for 0,8 diameter copper cable with a transmission rate of 192 kbps. Depending on the distance, the transmission rate can be configured to up to 11 Mbps. The status of any switch port can be signaled by two LED indicators, which are located in each lower and upper RJ45 jack or at the left side of the SFP slots.

A green Link LED (labeled L) indicates an active Ethernet connection with the states described below:

- Off No Connection
- On Ethernet Connection Established (Link)
- Flashing Ethernet Activity (Transmission or Reception of Frames)

A yellow Speed LED (labeled S) indicates a 100 Mbps connection with the following states:

- Off Ethernet Speed of 10 Mbps
- On Ethernet Speed of 100 Mbps

The state of the DSL interfaces can be monitored through the green LEDs labeled A (Activity) and L (Link). The LEDs for DSL port 1 are labeled A1 and L1, respectively A2 and L2 for DSL port 2. States for L1/L2:

- Off No DSL connection
- On DSL link established

States for A1/A2:

- Off No DSL connection
- Flashing DSL activity (Transmission or Reception of Frames)

Detected errors are signaled by a red Error LED (labeled ERR) together with an Alarm condition. The alarm condition can also be signaled by an isolated alarm relay, which can be deactivated by a jumper.

The conditions that lead to an alarm state can be configured.

Topology

The 560NMS24 provides a total of six ports for use with end devices, switches, bridges, hubs, routers or other 560NMS34, 560NMS24 or 560NMD01 using the DSL ports. Star, ring or line topologies can easily be built by this family of switches.

Redundant topologies are automatically detected and handled by the Rapid Spanning Tree Protocol (RSTP). This is fully backward compatible with the wide-spread Spanning Tree Protocol (STP).

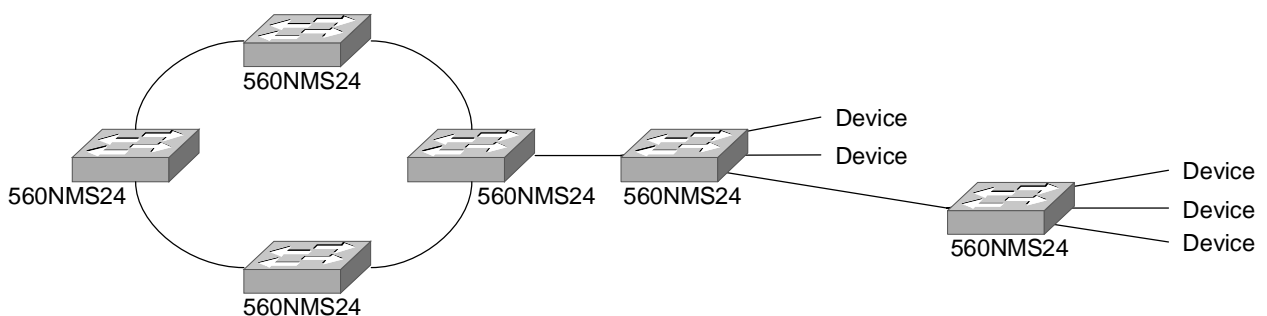

Fig. 2: Typical topology for use with 560NMS24

RTU560

Data Sheet Switch 560NMS24

Management and Configuration

Management and Configuration of the 560NMS24 can be done by Telnet, SNMP or Web-interface. All methods can be used to either read or write parameters of the device.

By default, the IP address for the configuration of a 560NMS24 switch is 10.0.0.2 with a subnet mask of 255.0.0.0 and a gateway of 10.0.0.1. The SNMP strings are 'public' for read-only access and 'private' for read-write operations. Any 560NMS24 can be reset to this state by a hardware jumper. Telnet connections for configuration are accepted through any Ethernet port. All Ethernet ports are administratively in default state.

Ports

All ports of the device can be disabled or enabled by configuration. Furthermore, the speed and duplex of any port can be set according to its capabilities. This is 10 or 100 Mbps, Full or Half duplex for the Ethernet ports and 192 kbps up to 11 Mbps in steps of 8 kbps for the SDSL ports.

It is also possible to use an auto-detect setting. For the SDSL ports it is recommended to set the 560NMS24 device closer to the control center to a fixed speed setting, while setting the communication partner at the RTU side to auto-detect.

Ports connected to a 560CMU0X should be configured with auto detect.

All ports are equipped with frame counters readable by the management software.

Alerts, Notifications and Logging

The 560NMS24 provides Syslog and SNMP capabilities to send alerts and notifications to one or more predefined destinations. There is also a relay for configurable out-of-band alerts.

For each Syslog server entry a severity can be entered to filter outgoing messages.

A system log stores critical messages. The log can be accessed by Telnet and implements a timestamp either by uptime, or date and time if a time server is configured.

For Syslog and local logging, a SNTP time server can be used to synchronize clocks and to enable the generation of date and time timestamps instead of uptime related messages.

Redundancy Support

The redundancy protocols Spanning Tree Protocol (STP) and Rapid Spanning Tree Protocol (RSTP) are fully supported. Without configuration RSTP is enabled for all ports. Switching from RSTP to STP is done automatically to ensure the compatibility to existing STP installations.

For every port, the (R)STP parameters can be configured separately. This includes port priority for root bridge control as well as point-to-point and edge connection settings. A global bridge priority is also settable.

Authentication

Access to the telnet interface of the 560NMS24 is controlled by a two-level password protection. The first level enables the user to access parameters in read-only mode and has to be entered as soon as a connection is established. To read and write parameters, the device has to be put in a configuration mode that requires an additional password. Any password can be disabled. Some security sensitive information, such as the configuration file, may not be available in read-only mode.

RTU560

Data Sheet Switch 560NMS24

Technical Data

Power

Operating Voltages 5 VDC \pm 10%

Power Consumption typ. 6.00 W, max. 8.00 W
(All RJ45 and DSL ports active)

Alarm

Status Indicator Red LED, label: ERR

Relais Contact Isolated Change Over
Contact

Relais max. switching Voltage / Current
DC 60 VDC / 0,5 A
AC 250 VAC / 0,24 A

Mechanical Layout

Printed circuit board 3HE, Euro-card
(160 x 100 mm)
Front panel 4R, 1 slot (20 mm)
Weight approx. 180 g

Connection Type

Power / Alarm Indirect, 48 pole
Connector DIN 41612 Type F

Environment

Operating Temperature
-25...70°C
rel. Humidity 5...95%
(non-condensing)

Electromagnetic Compatibility

Radio Interference IEC 55011
Power Supply Voltage Class B
Field Strength Class B
Electrostatic Discharge IEC 61000-4-2
8 kV Air, 6 kV Contact Criteria A
Electromagnetic Field Immunity IEC 61000-4-2
80 MHz to 3 GHz Criteria A
Surge & Burst Immunity IEC 61000-4-3 and -4
Surge 4 kV Criteria A
Burst 4 kV Criteria A
Conducted Disturbances Immunity IEC 61000-4-6
10 V, 0.15 MHz to 80 MHz, 80% AM 1 kHz
Criteria A
Mains Frequency Immunity IEC 61000-4-16
300 V Criteria A
Oscillatory Wave Immunity IEC 61000-4-18
2.5 kV Criteria A

RTU560

Data Sheet Switch 560NMS24

Ethernet

Connectors	4 x RJ-45
Status Indicators	Speed (10/100 Mbps): Amber LED Link/Activity: Green LED
Cable Type (RJ-45)	EIA/TIA Category 3 or ISO/IEC Class C cable or better for 10 Mbps EIA/TIA Category 5 or ISO/IEC Class D cable or better for 100 Mbps
Max. Cable Length	100 m for RJ45, for optical connection refer to SFP Module Data
Protocol	Fast-Ethernet according to IEEE 802.3-2005 Cl. 25 and IEEE 802.3u-1995 Ethernet according to IEEE 802.3-2005 Cl. 14 Auto-Negotiation (NWAY) according to IEEE 802.3-2005 Cl. 28 Auto-Crossover (Auto MDI/X)

Switching

Flow Control	Full Duplex Flow Control according to IEEE 802.3-2005 An. 31B and IEEE 802.3x-1997 Half Duplex Back Pressure
Max. Frame size	1552 Bytes
Quality of Service	IEEE 802.1p Tag based Pri- ority
MAC Lookup Table	Max. 2048 entries Max. 304 s hold time
Switching Mode	Store and Forward

Digital Subscriber Line

Connectors	2 x through backplane
Protocol	ETSI SDSL (ETSI TS 101 524 V 1.2.1) ETSI SDSL.bis (ETSI TS 101 524 V 1.2.2) ITU G.shdsl (ITU-T G.991.2) ITU G.shdsl.bis (ITU-T G.991.2 2004) ITU G.hs (ITU-T G.994.1) IEEE EFM (IEEE 802.3)

Supported Protocols

Spanning Tree	IEEE 802.1D-2004
Class of Service	IEEE 802.1p
VLAN Tagging	IEEE 802.1q
IP	RFC-791
ARP	RFC-826
ICMP	RFC-792
UDP	RFC-768
TCP	RFC-793
TFTP	RFC-783
CIDR	RFC-1519
Telnet	RFC-854
SNTP	RFC-2030
SNMP	RFC-1098
SNMP MIB-II	RFC-1213
Syslog	RFC-3164

Ordering Information

560NMS24 R0001 1KHW002108R0001

Note:

We reserve the right to make technical changes or modify the contents of this document without prior notice. With regard to purchase orders, the agreed particulars shall prevail. ABB AG does not accept any responsibility whatsoever for potential errors or possible lack of information in this document.

We reserve all rights in this document and in the subject matter and illustrations contained therein. Any reproduction, disclosure to third parties or utilization of its contents - in whole or in parts - is forbidden without prior written consent of ABB AG.

Copyright© 2011 ABB

All rights reserved