

Binary Input 23BE23

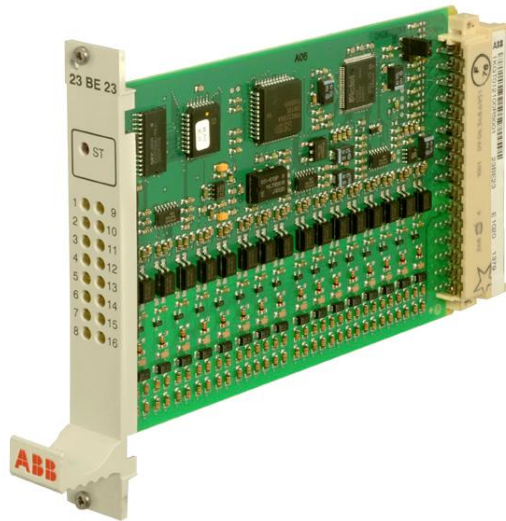

Application

The binary input board 23BE23 is used for the isolated input of up to 16 binary process signals. Scanning and processing of the inputs are executed with the high time resolution of 1 ms. Allocation of an input to a processing function can be done according to the rules of configuration. The board 23BE23 can process the following types of signals:

- 16 single indications with time stamp
- 8 double indications with time stamp
- 2 digital measured values with 8 bit
- 1 digital measured value with 16 bit
- 16 pulse counters

Characteristics

Eight inputs each form a group with a common return. The 16 inputs form two groups. The inputs are potentially isolated by means of optocouplers. The board allows process signal voltages from 24 to 60 V DC. The input circuit is dimensioned in that way, that current regulative diodes keep the signal current constant.

The board has sixteen light emitting diodes to indicate the signal-state. The LEDs are organized in two columns on the front plate. The LED follows directly the input.

The maximum permissible frequency for counter pulses is 120 Hz.

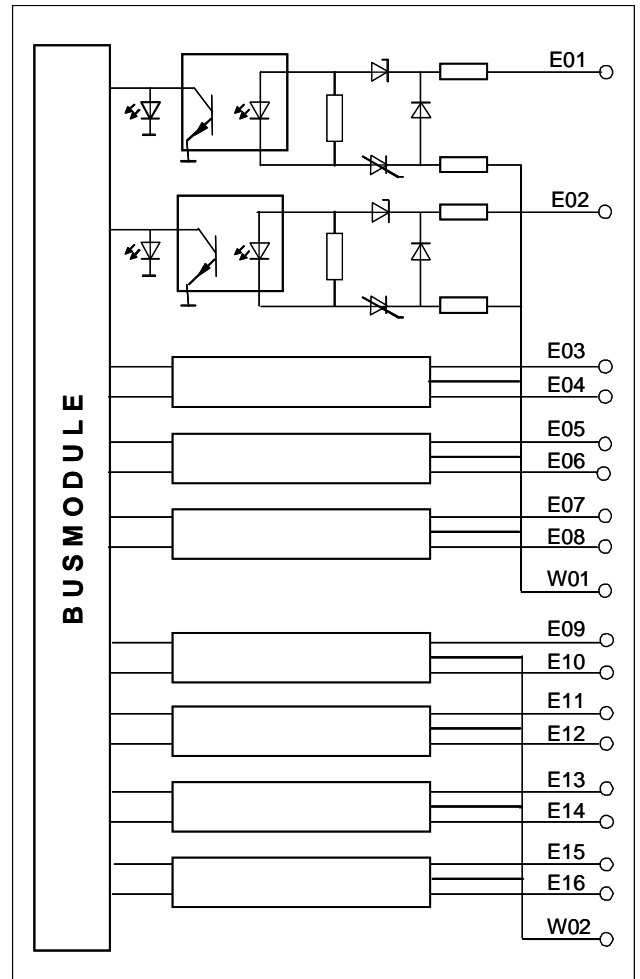

**Fig. 1: Block diagram
Binary input board 23BE23**

RTU560

Data Sheet Binary Input 23BE23

The binary input board 23BE23 can execute the following processing functions for the different types of signals:

- Digital filtering to suppress contact bounce
- Suppression of technologically caused chattering signals
- Consistency check for all binary input Intermediate position suppression and monitoring for double indications
- Channels allocated to digital measured values
- Summation of increment pulses to form counter values in 31 bit counter value registers
- Relocation of count values into other relocation registers on request

The effective functionality of the board depends on the executed firmware version. The selection of the requested firmware version for RTU560 stations is done by a jumper on the 23BE23 board.

The 23BE23 board has a buffer which allows the temporary storage of 50 time-stamped event messages in chronological order designated for transmission to the communication unit.

The micro-controller on the board processes all time-critical tasks of the parameterized processing functions. Moreover it carries out the interactive communication with the RTU560 system bus. All configuration data and processing parameters are loaded from the communication unit via the RTU560 system bus.

The board is equipped with a serial interface to the RTU560 system bus. This board can't be used in the basic-subrack of a RTU232 system (parallel system bus).

During initialization and operation the board carries out a number of tests. If a fault occurs it is reported to the communication unit. All fault conditions impairing the function of the board are displayed as common fault signal with a light emitting diode (ST) on the front panel. A failure of the board is detected by the communication unit.

RTU560

Data Sheet Binary Input 23BE23

Technical Data

In addition to the RTU560 general technical data, the following applies:

Input Channels

Inputs	16, in 2 groups of 8 with common return per group
Input voltage	24, 48, 60 V DC log. 0: $\leq +9$ V log. 1: $\geq +18$ V
Input current	Typically. 2 mA for 24 to 60 V DC

Power Supply

Supply	5 V / 140 mA
--------	--------------

Mechanical Layout

Printed circuit board	3HE, Euro card format (160 x 100)
Front panel	4R, 1 Slot (20 mm)
weight	approx. 0.2 kg

Connection Type

Connector	Indirect, 48 pole Type F DIN 41612
-----------	---------------------------------------

Test Voltage

AC Test Voltage EN 61000-4-16 IEC 60870-2-1 (class VW3)	2,5 kV, 50 Hz Test duration: 1 min
Impulse Voltage with stand test IEC 60255-5 IEC 60870-2-1 (class VW 3)	5 kV (1,2 / 50 μ s)

Immunity Test

Electrostatic discharge Immunity Test IEC 61000-4-2 (level 3)	6 kV Contact 8 kV Air Performance criteria A
Radiated Radio-Frequency Electromagnetic Field Immunity Test IEC 61000-4-3 (level 3)	10 V/m Performance criteria A
Immunity to Electrical Fast Transient / Burst IEC 61000-4-4 (level 3)	2 kV Performance criteria A
Surge Immunity Test IEC 61000-4-5 (level 3)	2 kV Performance criteria A
Immunity to Conducted Disturbances, induced by Radio-Frequency Fields IEC 61000-4-6 (level 3)	10 V Performance criteria A

Environmental conditions

Temperature	-10 ... 70 °C
Relative humidity	5 ... 95 % (non condensing)

Ordering Information

Front plate plastic	Light beige
23BE23 R5001	1 KGT 012 100 R5001

RTU560

Data Sheet Binary Input 23BE23

Note:

We reserve the right to make technical changes or modify the contents of this document without prior notice. With regard to purchase orders, the agreed particulars shall prevail. ABB AG does not accept any responsibility whatsoever for potential errors or possible lack of information in this document.

We reserve all rights in this document and in the subject matter and illustrations contained therein. Any reproduction, disclosure to third parties or utilization of its contents - in whole or in parts - is forbidden without prior written consent of ABB AG.

Copyright© 2011 ABB
All rights reserved

Power and productivity
for a better world™

