

Modem 23WT24



Application

The 23WT24 board is a modem with 9,6 kbps transmission speed. Therefore it can be used for the transmission via private networks. The modem 23WT24 is available in one version:

- R0001: 9,6 kbps Modem
Power Supply +5V DC

The board operates on the frequency shift keying principle (FSK). Two- or four-wire operation mode is selectable by jumper. The VF output has a high impedance which allows that up to 10 remote stations can be connected to a multi-drop line.

Characteristics

The board 23WT24 is a printed circuit in Euro-card format (160 mm x 100 mm). All necessary configuration like transmit output level, receiver sensitivity, two- or four-wire operation are configurable by jumper.

The interface to the data terminal equipment (DTE) operates according to the RS 232-C standard and supplies the following signals:

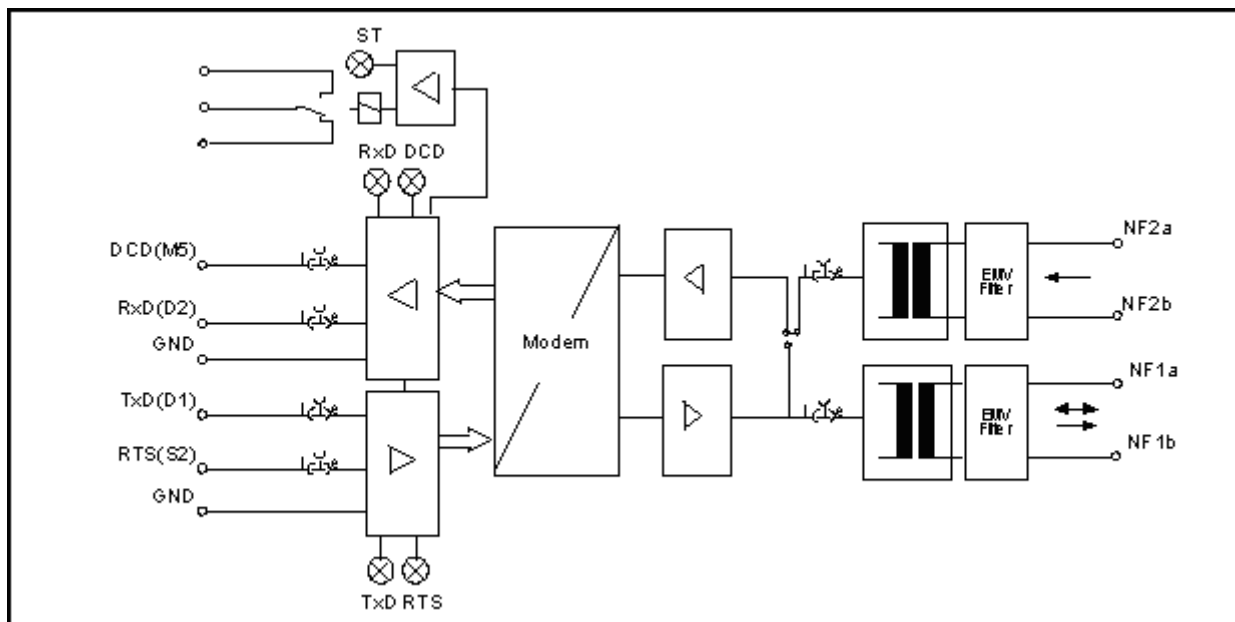

Fig. 1: Logic block diagram modem 23WT24

RTU560

Data Sheet Modem 23WT24

- TxD Transmit data
- RxD Receive data
- RTS Request to send
- DCD Data carrier detected
- CTS Clear to send
- DSR Data set ready

The receiver level is monitored and an alarm relay indicates in parallel to the light emitting diode (LED) "ST" a drop out for a longer period of the carrier (approx. 4-6 seconds).

LED's on the front plate show the signal state of the RS 232-C interface. By the disconnect test

sockets on the front plate the serial interface signals as also the VFT-lines can be measured or opened.

Additional VF signal transformer have to be used for requested higher isolation voltages. Surge voltage protection elements can be optional inserted on request to protect against transient over-voltage peaks (see Fig. 2).

The 23WT24 modem operates with 9,6 kBps in half- and full-duplex mode. This is why the modem 23WT24 has to be used on both sides of the transmission line.

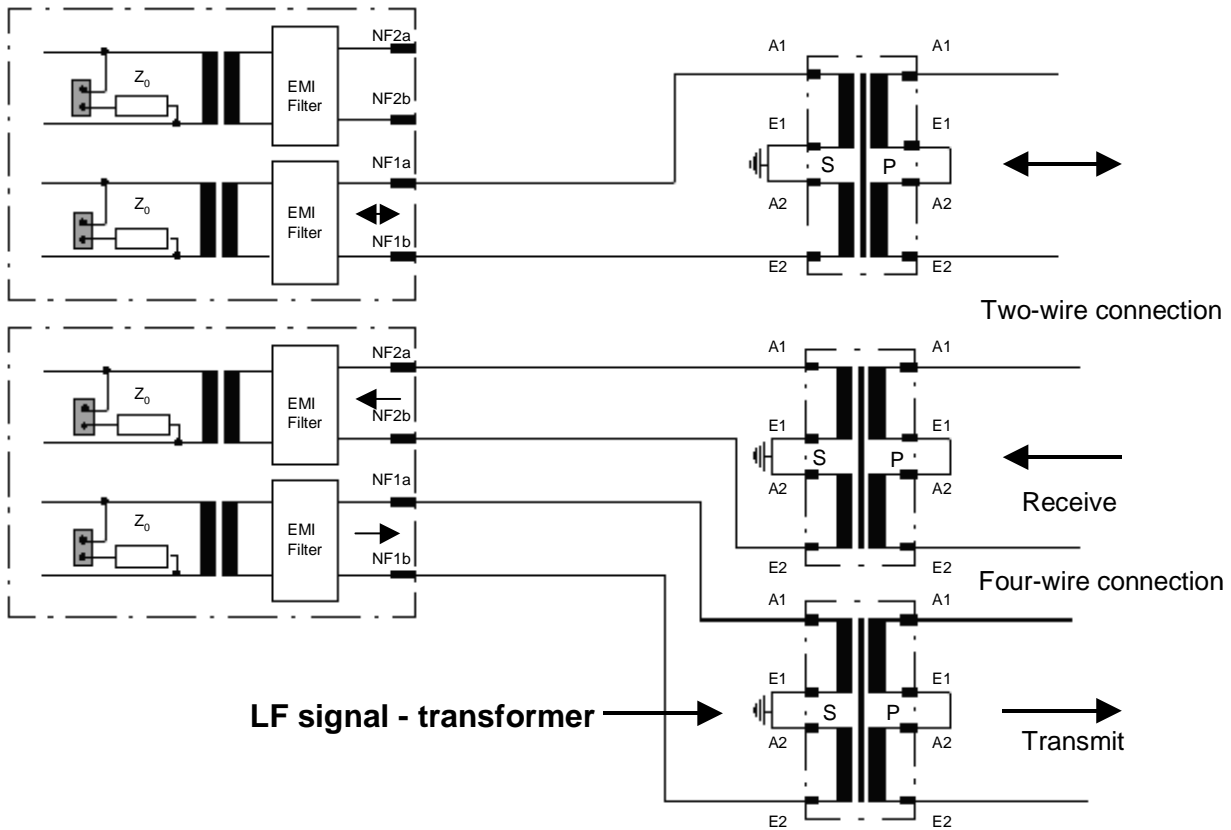

Fig. 2: Communication line connection by VF signal transformer

RTU560

Data Sheet Modem 23WT24

Technical Data

In addition to the RTU560 general technical data, the following applies:

General Data

Type of modulation: Frequency shift keying (FSK) with 9600 bps

Type of communication: point-to-point connection or multipoint network

Serial Interface

Standard: RS 232-C

Signal lines: D1 TxD/103
D2 RxD/104
S2 RTS/105
M2 CTS/106
M1 DSR/107
M5 DCD/109

Transmitter

Transmit output level at Z_A : -6 / -10 / -13 / -26 dBm by jumper

Output impedance: $130 \Omega + 150\text{nF} \parallel 931 \Omega$ non earthed and symmetrical or $> 6 \text{ k}\Omega$

Receiver

Receive level range: 0...-47 dBm

Sensitivity: -17 / -27 / -37 / -47 dBm by jumper

Input impedance: $130 \Omega + 150\text{nF} \parallel 931 \Omega$ non earthed and symmetrical or $> 6 \text{ k}\Omega$

Data format	Serial, binary, asynchronous		Dim
Traffic mode	Point-to-point or multi-drop		
Modulation type	Frequency shift keying (FSK) with carrier switch off for multi-drop networks		
Mid – frequency	13600		Hz
Frequency	MARK	9600	Hz
	SPACE	18000	Hz
Nominal transmission level	-6/-10/-13/-26		dBm ¹
Channel delay time RTS=ON to CTS=ON	Typical	1,6	ms
Channel delay time ² RTS=ON to DCD=ON	Minimum	2,0	ms
	Maximum	2,4	ms
Channel delay time ³ RTS=OFF to DCD=OFF	Minimum	0,1	ms
Upper identifier frequency	$F_A = F_C + \Delta F = \text{SPACE} = \text{TxD (D1)}$		
Lower identifier frequency	$F_Z = F_C - \Delta F = \text{MARK} = \text{TxD (D1)}$		

¹ As voltage level related to 775 mV

² Without influence of the transmission channel

³ Without influence of the transmission channel

RTU560

Data Sheet Modem 23WT24

Level monitoring and alarm relay

Alarm delay time: approx. 5 s
Alarm relay (contact): 60 V DC / 0,5 A / 30 W

Power Supply:

Supply: 5 V DC / 350 mA

Mechanical Layout

Printed circuit: 3HE, Euro-card format
(160 x 100 mm)
Front panel: 4R, 1 slot (20 mm)
Weight: approx. 250 g

Connection type

Connector: indirect, 48 pole
Type F DIN 41612

Test voltage

DC test voltage: 500 V DC
CECC 42000

Electromagnetic Compatibility

Electrical fast transient test: 1 kV
IEC 801-4, class 2

Environmental Conditions

Temperature: 0 ... 70° C
Relative humidity: 5 ... 95%
(non condensing)

Ordering Information

23WT24 R0001 1KGT010500R0001

Note:

We reserve the right to make technical changes or modify the contents of this document without prior notice. With regard to purchase orders, the agreed particulars shall prevail. ABB AG does not accept any responsibility whatsoever for potential errors or possible lack of information in this document.

We reserve all rights in this document and in the subject matter and illustrations contained therein. Any reproduction, disclosure to third parties or utilization of its contents - in whole or in parts - is forbidden without prior written consent of ABB AG.

Copyright© 2011 ABB
All rights reserved

Power and productivity
for a better world™

