

Application

The 23BA23 board is intended for the use in the Remote Terminal Unit RTU560.

The 23BA23 board should be installed if the output circuit of an object command has to be checked before the actual command is given. The 23BA23 board executes an 1 out of n check. It checks if only one interposing relay will be activated in the output circuit. This is feasible only if all interposing relays connected to one check circuit have the same resistance value.

The 23BA23 board allows to check two different interposing relay types by using two separated check circuits. The permissible tolerance range is defined by means of parameters.

Up to 16 23BA23 boards can be used in one RTU560.

The 23BA23 board is functional and pin-compatible to the 23BA22 board only in a RTU560 system. The essential additional tasks are:

- Galvanic isolation of the check circuit
- Suppression of line frequency during measuring

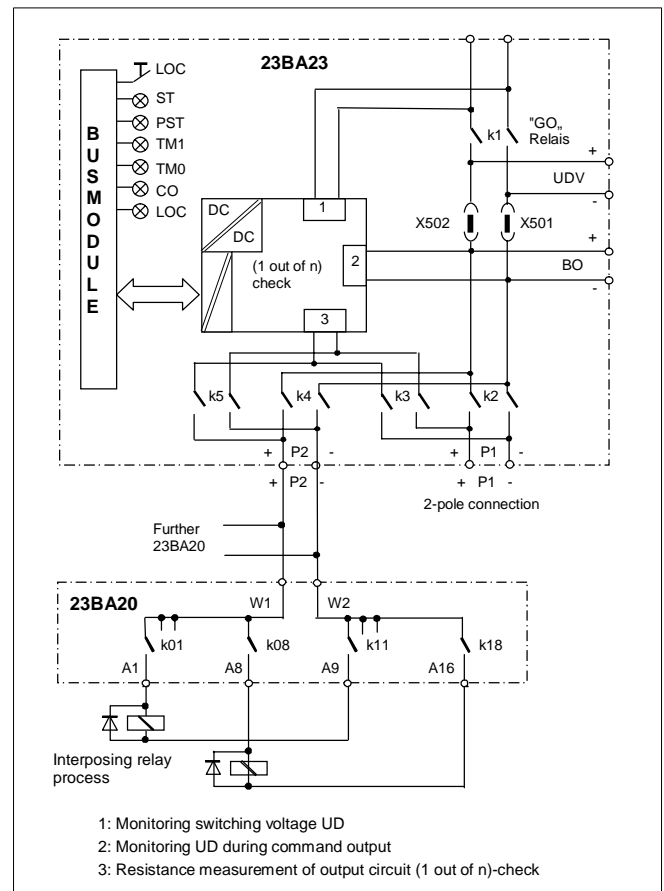

Fig.1: Block diagram 23BA23

An auxiliary test voltage is not necessary. During measuring the 23BA23 board switches the respective check circuit (P1 or P2) two-pole and therefore separates both.

In the (1 out of n)-check the 23BA23 board measures the resistance value in the output circuit and compares this value with the configured upper and lower limit values.

If the resistance value is within the limits the selected interposing relay can be activated. The object command will be acknowledged positively.

If the measured resistance value is outside the tolerance limits the 23BA23 blocks the output and indicates the error to the CMU (CMU = communication unit).

The central unit controls and coordinates the appropriate 23BA20 and 23BA23 boards.

After the 23BA20 has switched on the 23BA23 gets the order to check and to output the object command. The 23BA23 switches the output circuit to the check circuit via relay k3 (check circuit 1) or relay k5 (check circuit 2). The resistance is determined by the arising measuring circuit voltage by output of a constant current. The output

RTU560

Data Sheet Command Output Monitoring 23BA23

constant current is defined by the configured upper coil resistance. If the measured resistance value is within the tolerance range, relay k3 (k5) is switched off and relay k2 (k4) is switched on. After that relay k1 switches the selected interposing relay and releases the object command.

The limits of the coil resistance for the interposing relay can be adjusted in steps of $10\ \Omega$ in the range of $100\ \Omega$ to $10\ 000\ \Omega$ by means of parameters. Line frequency ripple voltages will be filtered by the A/D converter.

The direct activation of process relays on electrical apparatus (isolators, circuit-breakers) is possible by using an additional booster relay (Fig. 2)

At command output not the output circuit itself is switched by k1 but the booster relay (KB) instead. This booster relay connects the switching voltage UD1 via relay kB and k2 (k4) to the process relay with higher switching current. This ensures that the relay contacts k2 (k4) of the 23BA23 and k01 to k18 of the 23BA20 are switched without load.

The selection of the booster relay depends on the switching capacity on the electrical apparatus. It must be taken into consideration that the relay characteristics of the output boards 23BA20 and 23BA23 are not exceeded.

For diagnostic purposes switching through of the switching voltage can be inhibited by pressing the LOCAL key (LOC). The relays k2 (k4) and k1 then will be blocked. All other output functions including the (1 out of n)-check will be carried out.

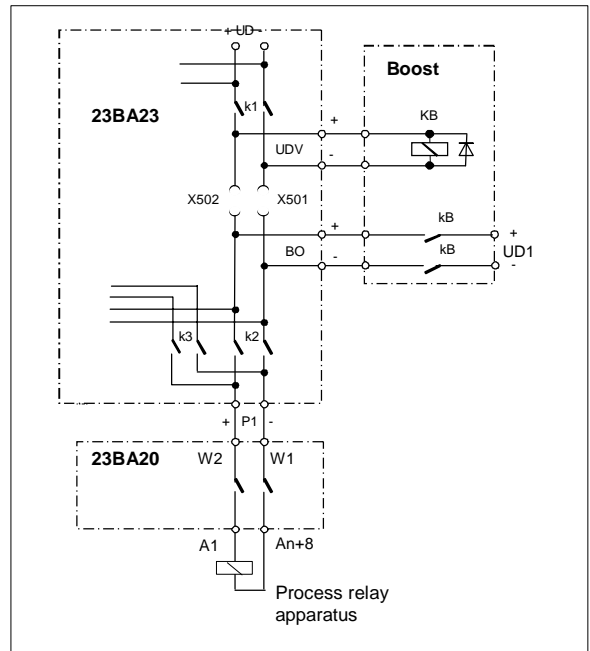

Fig 2: Relay activation by means of a booster relay

To ensure correct output the board carries out several monitoring functions before and during command output:

- Monitoring of output duration and reset in case of fault
- Monitoring of switching voltage before and during the command output

Operating states and faults are displayed by light emitting diodes on the front panel of the 23BA23:

- ST** Common malfunction
- PST:** Display of process fault conditions when monitoring responds (Command output error)
- TM0, TM1:** Display of active operating states of the two test circuits
- CO:** Display of active command output (Command Output)
- LOC:** LOCAL function activated

The micro-controller of the board is responsible for interactive communication with the RTU system bus. All configuration characteristics and processing parameters are downloaded from the communication unit. Therefore no parameter settings on the board are required (Exception: Line frequency for the ripple voltage suppression function).

RTU560

Data Sheet Command Output Monitoring 23BA23

The board is equipped with both a serial and a parallel interface to the RTU system bus.

During initialization and operation the board carries out a number of tests. If a fault occurs this is reported to the communication unit. All fault condi-

tions impairing the function of the board are displayed as common fault signal with the light emitting diode (ST) on the front panel. A failure of the board is detected by the communication unit.

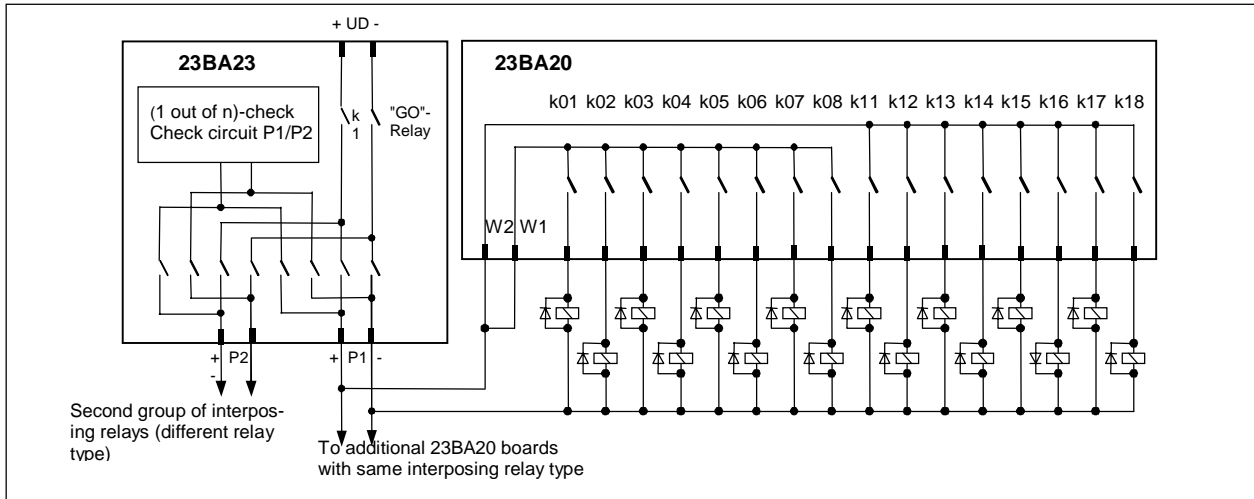

Fig. 3 :-Block diagram: Object command output with (1 out of n)-check at 1.5 pole connection

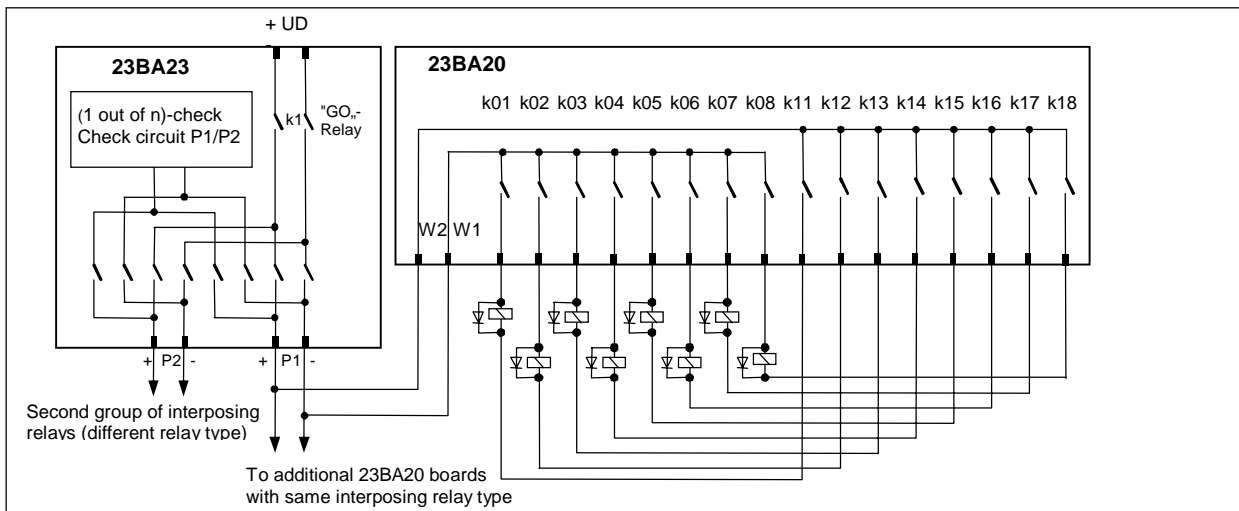

Fig. 4: Block diagram: Object command output with (1 out of n)-check at 2 pole connection

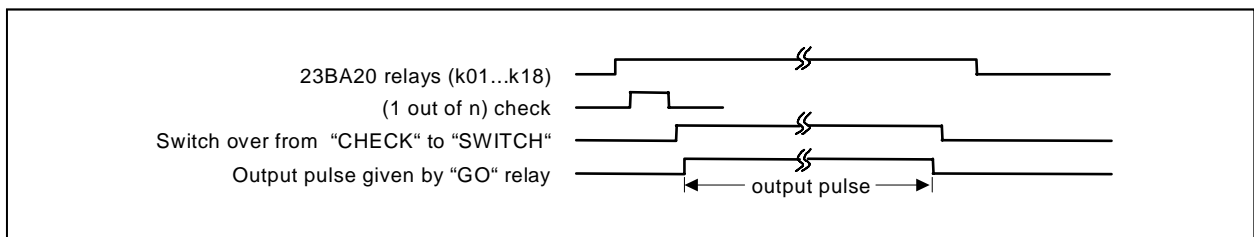

Fig. 5: Timing diagram of command output: Coordination of 23BA23 and 23BA20 by communication unit

RTU560

Data Sheet Command Output Monitoring 23BA23

Power and productivity
for a better world™ 

Technical Data

In addition to the general technical data of the RTU560 the following applies:

Output Channels

Test and switching circuits:	2
Measuring range of test circuits:	100 ... 10000 Ω
Resolution:	10 Ω
Measuring current:	0,25... 5 mA
Ripple voltage:	16 2/3 / 50 and 60 Hz
suppression:	
Input voltage range of the measuring circuit (this limits the max. allowed ripple voltage):	- 0,5 ... + 6 V

Relay characteristics in connection with 23BA23

Switching voltage (UD)	Max. 60 V DC
Max. switching capacity:	
- resistive load	60 W
- inductive load at L/R = 30 ms	40 VA (at 60 V DC)

Characteristics in connection with a booster relay

Switching voltage (UD)	Max. 60 V DC
Continuous current:	4 A (at object command duration 25 sek.)

Power Supply

Supply:	5 V / max. 130 mA 24 V / max. 70 mA without 24 V / max. 100 mA with command output
---------	---

Mechanical Layout

Printed circuit board:	3HE, Euro-card format (160 x 100 mm)
Front panel:	4R, 1 slot (20 mm)
Weight:	Approx. 0.2 kg

Connection Type

Connector:	Indirect, 48 pole Type F DIN 41612
Environmental Conditions	
Temperature:	-20° - 70° C
Relative humidity:	5 ... 95 % (non condensing)

Ordering Information

23BA23	1KGT 020 800 R001
--------	-------------------

Note:

We reserve the right to make technical changes or modify the contents of this document without prior notice. With regard to purchase orders, the agreed particulars shall prevail. ABB AG does not accept any responsibility whatsoever for potential errors or possible lack of information in this document.

We reserve all rights in this document and in the subject matter and illustrations contained therein. Any reproduction, disclosure to third parties or utilization of its contents - in whole or in parts - is forbidden without prior written consent of ABB AG.

Copyright© 2011 ABB
All rights reserved