

Main dimensions comply IEC 72-1, Swedish standard SS 426 04 02 and German standard DIN 42673. Dimensions are given in millimetres and are not binding unless specifically stated. The rotor are dynamically balanced with the half key on the shaft end.

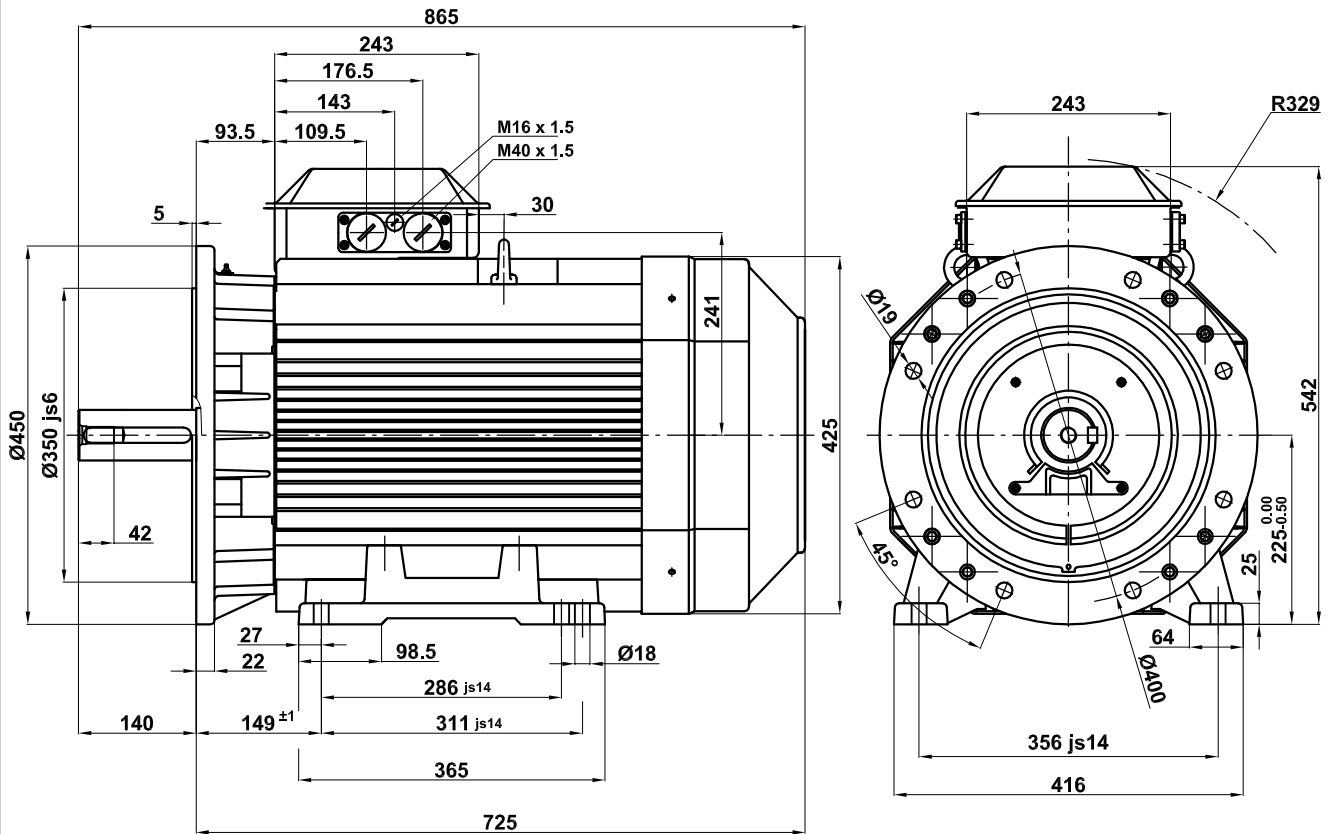
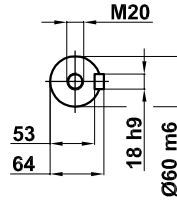

Dimensiones principales obedecen a la norma IEC 72-1, estandar Sueca SS 426 04 02 y estandar Alemana DIN 42673.

Dimensiones en milímetros salvo otras indicaciones.

El rotor está equilibrado dinamicamente con media chaveta en el acople.

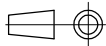

SMA- 4 ÷ 8
SMB- 4 ÷ 8
SMC- 4 ÷ 8 H.O.

| | | |
|--|---|---|
| Motor Dimension Print | Motor Type : M3AA 225 CODE D | Document N° : A1.4278 |
| Description : Motor food and flage mounted IM2001 / Motor con patas y brida IM2001 | |  |
| Unit : División Motores, Spain. Date : 2005-06-30 | Issued by : IKA/ J.MUÑOZ Approved by : IKA/ R.PERERA | Replaces : To date 2004-02-09 Replaced by : |
| ABB Automation Products, S.A. | Customer Reference : | |
|  | | |