

$\varnothing 120m6 (+0.035 / -0.013)$

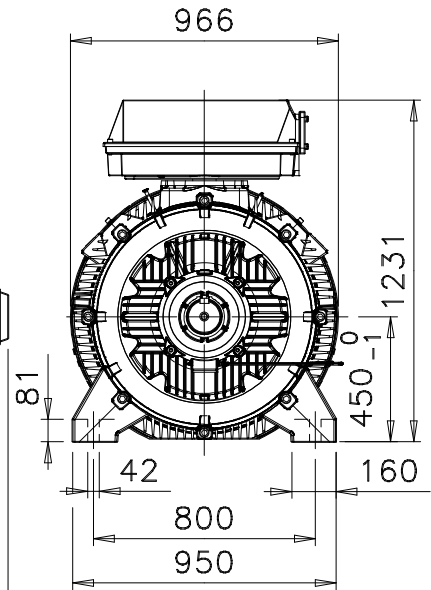
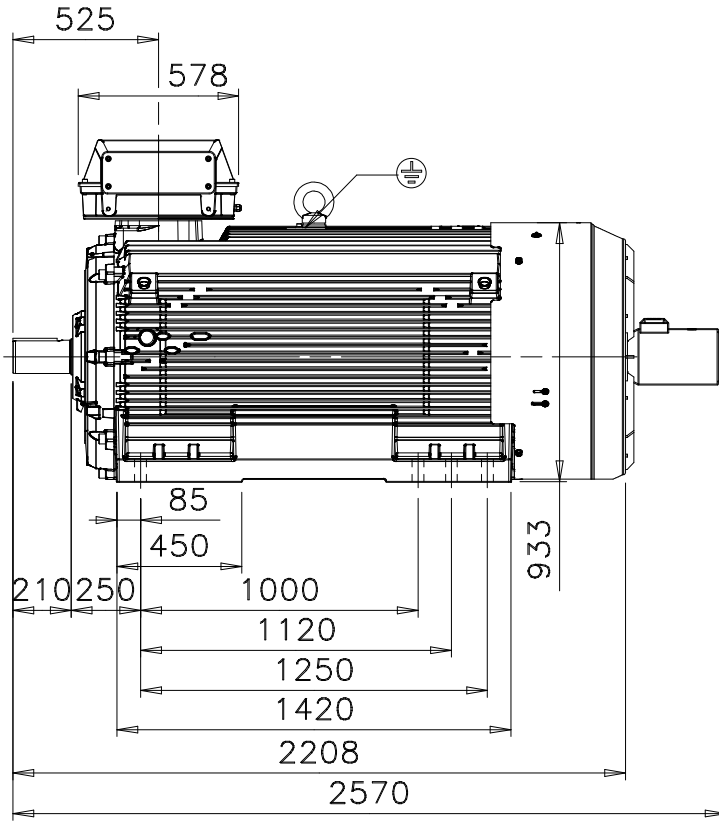
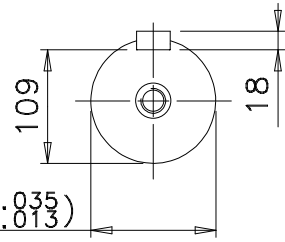

Additional information:

<b>Dimension Print</b>	Motor Type: M3BP 450L_4-12 B3, B6, B7, B8, V5, V6 M3HP/GP 450L_4-12 B3, B6, B7, B8, V6	Document No: 3GZF500045-21 B 14 BP 450 A
	Description: SQUIRREL CAGE MOTOR WITH SEPARATE COOLING, TERMINAL BOX 1200	
Unit: Motors Date: 22.07.2009	Issued by: A-R.Mäki Approved by: M.Sevola	Replaces: Replaced by:
<b>ABB Oy</b>	Customer Reference:	<b>ABB</b>