

# Delay On Make/Break

## CT Series HVAC/R Timer

5



- Delay on Make and Delay on Break In One Unit
- Use For Fan Delays in Heating or Cooling Equipment
- Use For Multiple Load Sequencing
- 24 V AC Operation
- Factory Fixed Delays From 1 ... 600 s in 1 s Increments

Approvals:

### Accessories



Mounting bracket  
P/N: **P1023-6**



Female quick connect  
P/N:  
**P1015-64** (AWG 14/16)



Quick connect to screw adaptor  
P/N: **P1015-18**



DIN rail P/Ns:  
**017322005** (Steel)  
**C103PM** (Al)

DIN rail adaptor  
P/N: **P1023-20**

See accessory pages for specifications.

### Description

The CT Series combines a delay on make and delay on break time delay into one unit and may be used to control fan delays in heating and/or cooling equipment. The CT includes bypass circuitry to allow it to operate with cooling anticipators  $\geq 3000$  ohms. It is designed to operate in 24 V AC control circuits. Several CT modules may be combined to provide sequencing ON of any number of loads and sequencing OFF of the same loads, such as electric heating elements.

### Operation

**Forced Air Heating or Air Conditioning (as shown):** When the thermostat closes, the compressor relay is immediately energized. At the end of a fixed delay on make delay (T1), the fan relay is energized. When the thermostat opens, the compressor relay is de-energized and the delay on break delay is initiated. On completion of the fixed delay on break delay (T2) the fan relay is de-energized. If the thermostat is reclosed during the delay on break delay, the unit is reset and the fan relay remains energized.

### Function

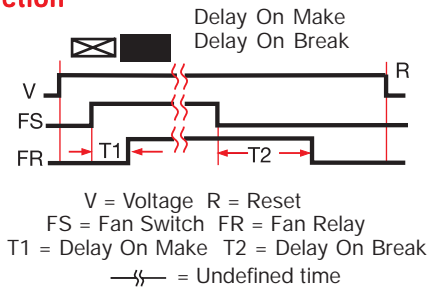

### Connection

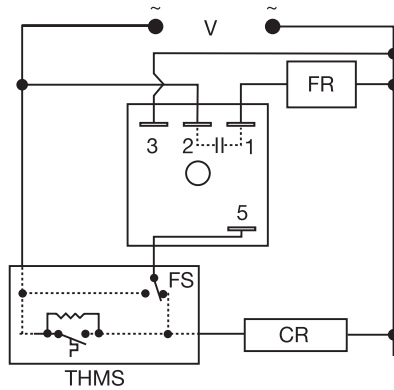

CR = Compressor Relay THMS = Wall Thermostat  
Dashed lines are internal connections.

### Ordering Table

CT  
Series

**X**  
Delay on Make (Fixed)  
Specify time in seconds from  
**1 ... 600** s  
followed by (S)

**X**  
Delay on Break (Fixed)  
Specify time in seconds from  
**1 ... 600** s

Example P/N: **CT1S120, CT20S60**

# Delay On Make/Break

## CT Series

### HVAC/R Timer

#### Technical Data

<b style="color: red;">Time Delay</b> Type Range Repeat Accuracy Tolerance (Factory Calibration) Recycle Time vs. OFF Delay Period	Analog circuitry 1 ... 600 s +/-5% +/-20% <b>Recycle Time *      % of OFF Period</b> 1 s                      50% 1 m                     70% 5 m                     90% * Note: Time thermostat is closed
<b style="color: red;">Input</b> Voltage Tolerance Line Frequency	24 V AC +/-15% 60 Hz
<b style="color: red;">Output</b> Type Form Rating Voltage Drop	Solid state Normally open 0.75 A steady state, 5 A inrush at 55°C ≅ 1.25 V
<b style="color: red;">Protection</b> Circuitry Dielectric Breakdown Insulation Resistance	Encapsulated ≥ 2000 V RMS terminals to mounting surface ≥ 100 MΩ
<b style="color: red;">Mechanical</b> Mounting Package Termination	Surface mount with one #10 (M5 x 0.8) screw 2 x 2 x 1.21 in. (50.8 x 50.8 x 30.7 mm) 0.25 in. (6.35 mm) male quick connect terminals
<b style="color: red;">Environmental</b> Operating Temperature Storage Temperature Humidity Weight	-40°C ... +70°C -40°C ... +85°C 95% relative, non-condensing ≅ 2.4 oz (68 g)
<b style="color: red;">Thermostat</b>	Anticipator Resistor: ≥ 3000 Ω

5

