



Section 5 Dedicated Timers

5

Single Function



Delay on Make (ON Delay)		Single Shot, Retriggerable (Watchdog, Zero Speed)	
Relay Output	5.2	Relay Output	5.122
Solid State Output	5.16	DIN Rail Mounting	5.126
DIN Rail Mounting	5.34	Trailing Edge Interval	
Delay on Make, Normally Closed		DIN Rail Mounting	5.128
Solid State Output	5.44	Interval (Impulse ON)	
Delay on Break (OFF Delay)		Relay Output	5.134
Relay Output	5.52	Solid State Output	5.142
Solid State Output	5.64	DIN Rail Mounting	5.160
DIN Rail Mounting	5.80	Recycling & Percentage	
True Delay on Break (without auxiliary voltage)		Relay Output	5.166
Relay Output	5.90	Solid State Output	5.178
Solid State Output	5.94	Recycling Flashers	
Single Shot (Pulse Former)		DIN Rail Mounting	5.198
Relay Output	5.96		
Solid State Output	5.110		

Sequencer



SQ3 & 4 -- Solid State Output	5.208
-------------------------------------	-------

Dual Function



Delay on Make/Delay on Break	
TDMB -- Plug-In	5.210
CT-EAS -- DIN Rail Mounting	5.212
CT-EVS -- DIN Rail Mounting	5.214
Delay on Make/Interval	
ESD5 -- Solid State	5.216
CT-PGS -- DIN Rail Mounting	5.218

HVAC Timers



Solid State Output	
TAC1 -- Anti Short Cycle Random Start	5.220
T2D -- Anti Short Cycle, Random Start	5.222
TAC4 -- Bypass Timing	5.224
TA -- Anti Short Cycle (DOB)	5.226
TL -- Anti Short Cycle (DOB)	5.228
CT -- Fan Delay	5.230

Vending Timers



HRV -- Relay Output	5.232
THC/THS -- Solid State Output	5.234
KSPU -- Solid State Output	5.236
NHPU -- Solid State Output	5.238

Star Delta Motor Starting



DIN Rail Mounting	
CT-YDAV	5.240
CT-YDEW	5.242
CT-SDE	5.244
CT-YDE	5.246

Star-Delta Starting (Delay On Make/Delay on Make) CT-YDAV Timer Relay Output



- Star-Delta Starting
- 10 Time Ranges, 0.05 s...300 h in One Unit
- Variable Time Range (start-up) and Fixed Changeover Time of 50 ms
- 2 SPDT Contacts
- 3 LED's to Display Status
- Supply Voltage 380...440 V AC or 24 V, 42...48 V DC, & 110...240 V AC

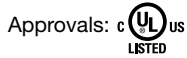

Accessories

Panel Mounting Adapter
22.5 mm
P/N: 1SVR 430 029 R 0100

Transparent Cover
22.5 mm
P/N: 1SVR 430 005 R 0100

Marker Insert
P/N: 1SVR 366 017 R 0100

See accessory pages for specifications.

Operation

Star Delta Motor Starting: (Two Delay on Make Delays): See connection and wiring diagrams. Upon application of supply voltage by closing switch S2, the STAR starting time delay begins. The STAR contactor K1 (connects motor windings in WYE) is energized through the normally closed contacts 15/16 of the CT-YDAV. The K2 contactor is energized by contacts 13/14 of the K1 contactor. K2 then latches on through its own contacts 13/14. At the end of the time delay, (K1T) 15/16 transfers disconnecting the STAR contactor K1. After a 50 ms fixed delay, the second set of CT-YDAV relay contacts (K1T) 25/28 close energizing the Delta winding contactor K3.

Reset: Removing supply voltage (by opening the S1 stop switch) unlatches the K2 contactor and resets the timer.

Time Ranges

1	0.05 - 1 s*	6	15.0 - 300 s
2	0.15 - 3 s*	7	1.50 - 30 min.
3	0.50 - 10 s	8	15.0 - 300 min.
4	1.50 - 30 s	9	1.50 - 30 h
5	5.00 - 100 s	10	15.0 - 300 h

* In this time range, the green LED does not flash during timing.

Connection

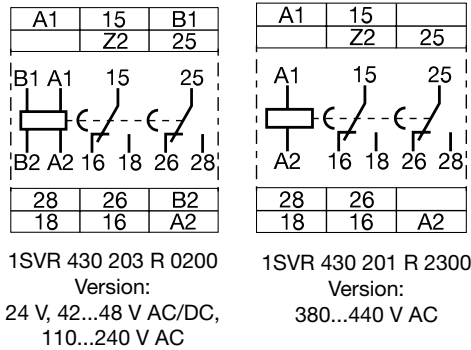

Function

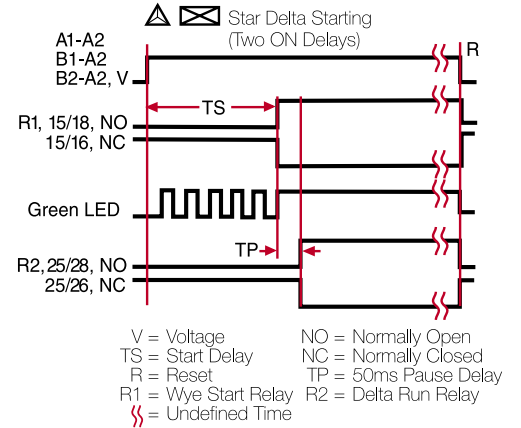

Control Circuit Diagram

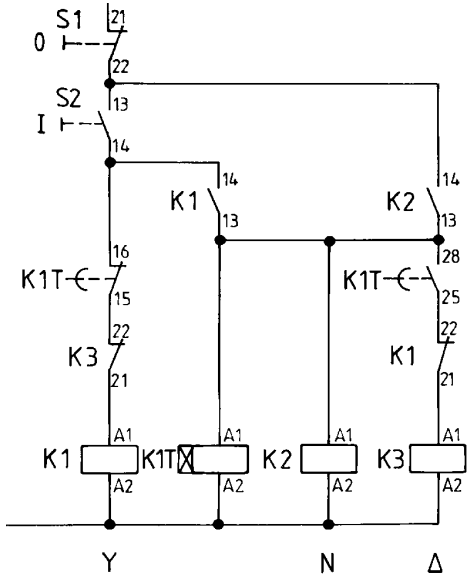

Power Circuit Diagram

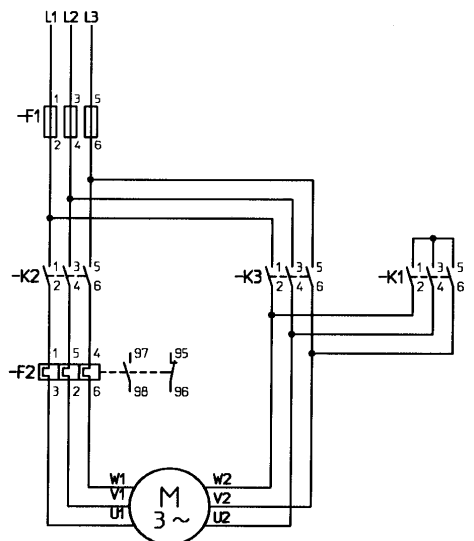

Mechanical View

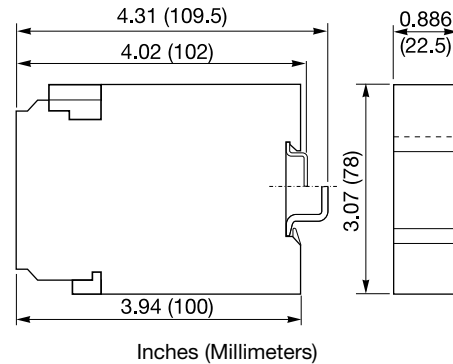

Ordering Table

Supply Voltage	Part Number
24 V, 42...48 V AC/DC, 110...240 V AC	1SVR 430 203 R 0200
380...440 V AC	1SVR 430 201 R 2300

Star-Delta Starting (Delay On Make/Delay on Make) CT-YDAV Timer Relay Output

Technical Data

Input		
Supply voltage - power consumption	B1-A2 B2-A2 A1-A2 A1-A2	24 V AC/DC - approx. 0.5 VA / W 42...48 V AC/DC - approx. 2 VA/ W 110...240 V AC - approx. 2.5...12 VA 380...440 V AC - approx. 3 VA
Tolerance of the supply voltage		-15 % ... +10 %
Supply voltage frequency		50...60 Hz or DC
Time Delay		
Time range		0.05 s ... 300 h in 10 ranges
Reset time		< 50 ms
Repeat accuracy (constant parameters)		< 0.2 %
Timing error over the supply voltage range		< 0.008 % / % ΔV
Timing error over the temperature range		< 0.07 % / °C
Display of operational status		
Supply voltage/ timing		LED green steady / flashing during timing
1st output relay energized		LED red
2nd output relay energized		LED red
Output		
Rated voltage	15-16/18, 25-26/28 VDE 0110, IEC 947-1	Relay, 2 SPDT contacts 250 V
Rated switching voltage		250 V AC
Rated switching current	AC 12 (resistive) AC 15 (inductive) DC 12 (resistive) DC 13 (inductive)	4 A (at 230 V) 3 A (at 230 V) 4 A (at 24 V) 2 A (at 24 V)
Maximum mechanical life		30 x 10 ⁶ operations
Maximum electrical life (to AC 12 / 230 V/4 A)		1 x 10 ⁵ operations
Short-circuit proof, max. fuse rating		10 A / fast acting
General data		
Rated impulse withstand voltage Vimp		4 kV
Operating temperature		-20°C ... +60°C
Storage temperature		-40°C ... +85°C
Mounting of DIN rail (EN 50022)		Snap-on/Screw mounting using an adapter
Wire size stranded with wire end ferrule		2 x 14 AWG (2 x 2.5 mm ²)
Weight		Approx. 5.3 oz (150 g)

Load Limit Curves

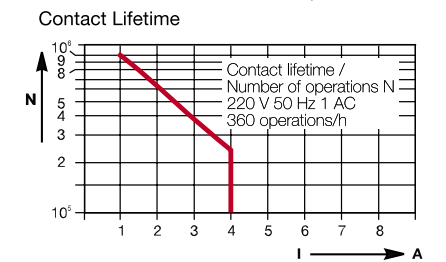
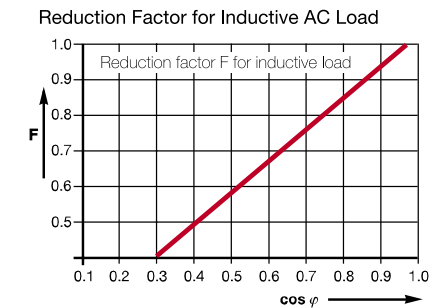
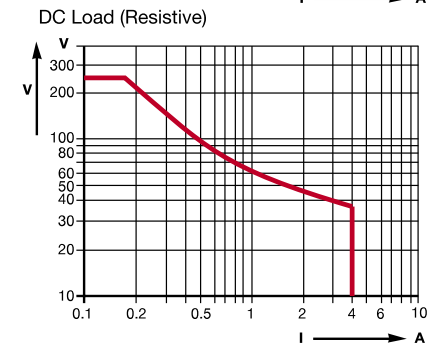
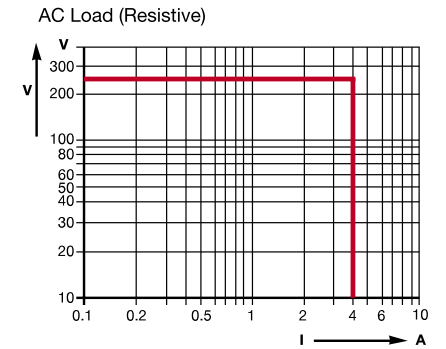

Face View

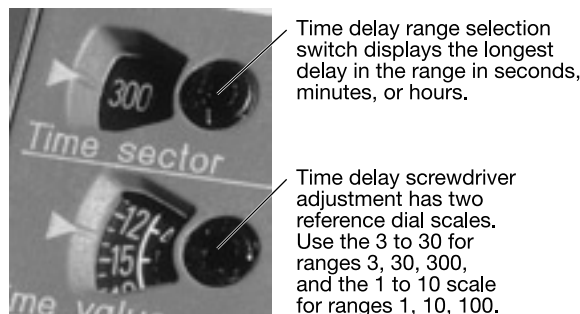
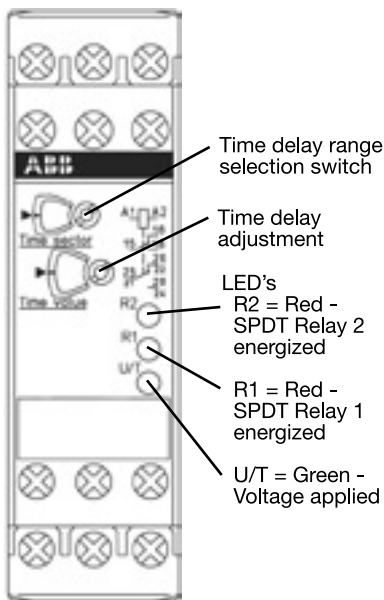

Star-Delta Starting (Interval/Delay on Make) CT-YDEW Timer Relay Output



- Star-Delta Starting (Interval/Delay on Make)
- 10 Time Ranges, 0.05 s...300 h in One Unit
- Variable Time Range (start-up) and Fixed Changeover Time of 50 ms
- 1 SPDT Delayed Contact
- 1 SPDT Start Contact
- 3 LED's to Indicate Status

Approvals: us

Operation

Star Delta Motor Starting: (Interval and Delay on Make Delays): See connection and wiring diagrams. Upon application of supply voltage by closing switch S2, the STAR starting time delay begins. The STAR contactor K1 (connects motor windings in WYE) is energized through the CT-YDEW contacts (K1T) 17/18. The K2 contactor is energized by contacts 13/14 of the K1 contactor. K2 then latches on through its own contacts 13/14 & 53/54. At the end of the starting time delay, the start winding contactor K1 de-energizes through K1T 17/18. After a 50 ms fixed delay, the second set of CT-YDEW relay contacts (K1T) 17/28 close energizing the Delta winding contactor K3.

Reset: Removing supply voltage (by opening the S1 stop switch) unlatches the K2 contactor and resets the timer.

Time Ranges

1	0.05 - 1 s*	6	15.0 - 300 s
2	0.15 - 3 s*	7	1.50 - 30 min.
3	0.50 - 10 s	8	15.0 - 300 min.
4	1.50 - 30 s	9	1.50 - 30 h
5	5.00 - 100 s	10	15.0 - 300 h

* In this time range, the green LED does not flash during timing.

Connection

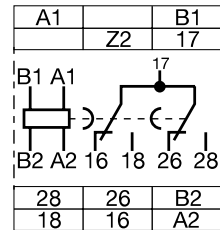

Control Circuit

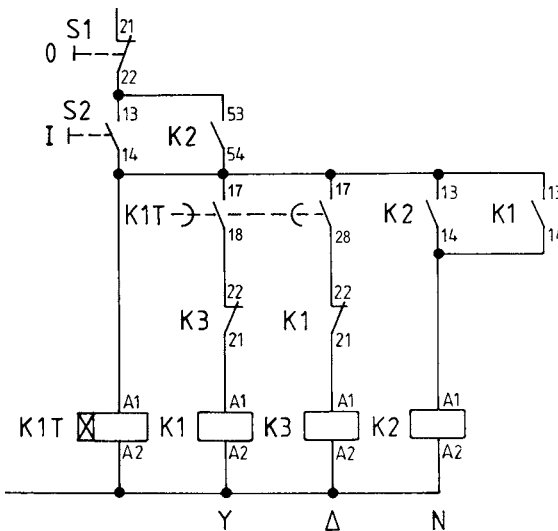

Function

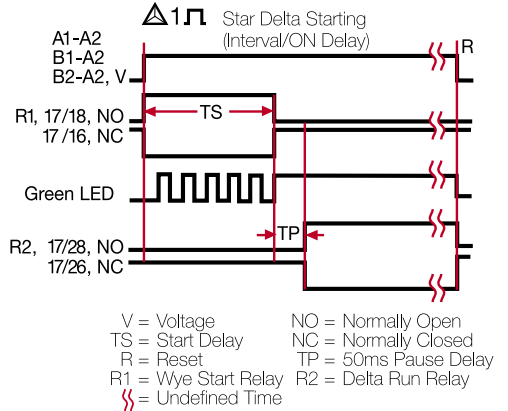

Power Circuit

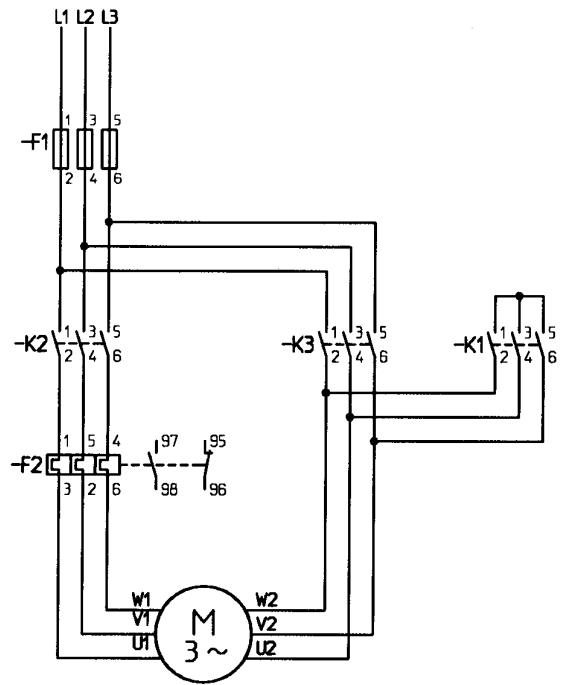

Mechanical View

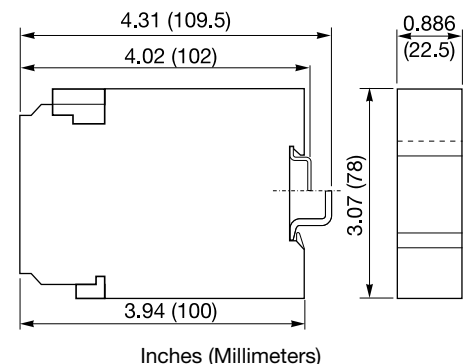

Accessories

- Panel Mounting Adapter
22.5 mm
P/N: 1SVR 430 029 R 0100
- Transparent Cover
22.5 mm
P/N: 1SVR 430 005 R 0100
- Marker Insert
P/N: 1SVR 366 017 R 0100

See accessory pages for specifications.

Ordering Table

Supply Voltage	Part Number
24 V, 42...48 V AC/DC, 110...240 V AC	1SVR 430 213 R 0200

Star-Delta Starting (Interval/Delay on Make) CT-YDEW Timer Relay Output

Technical Data

Input		
Supply voltage - power consumption	B1-A2 B2-A2 A1-A2	24 V AC/DC - approx. 0.5 VA / W 42...48 V AC/DC - approx. 2 VA/ W 110...240 V AC - approx. 2.5...12 VA
Tolerance of the supply voltage		-15 % ... +10 %
Supply voltage frequency		50...60 Hz or DC
Time Delay		
Time range		0.05 s ... 300 h in 10 ranges
Reset time		< 50 ms
Repeat accuracy (constant parameters)		< 0.2 %
Timing error over the supply voltage range		< 0.008 % / % ΔV
Timing error over the temperature range		< 0.07 % / °C
Display of operational status		
Supply voltage/ timing		LED green steady / flashing during timing
1st output relay energized		LED red
2nd output relay energized		LED red
Output		
Rated voltage	17-16/18, 17-26/28 VDE 0110, IEC 947-1	Relay, 2 SPDT contacts 250 V
Rated switching voltage		250 V AC
Rated switching current	AC 12 (resistive) AC 15 (inductive) DC 12 (resistive) DC 13 (inductive)	4 A (at 230 V) 3 A (at 230 V) 4 A (at 24 V) 2 A (at 24 V)
Maximum mechanical life		30 x 10 ⁶ operations
Maximum electrical life (to AC 12 / 230 V/4 A)		1 x 10 ⁵ operations
Short-circuit proof, max. fuse rating		10 A / fast acting
General data		
Rated impulse withstand voltage V _{imp}		4 kV
Operating temperature		-20°C ... +60°C
Storage temperature		-40°C ... +85°C
Mounting on DIN rail (EN 50022)		Snap-on/Screw mounting with an adapter
Wire size stranded with wire end ferrule		2 x 14 AWG (2 x 2.5 mm ²)
Weight		Approx. 5.3 oz (150 g)

Load Limit Curves

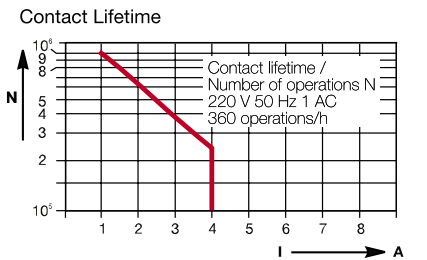
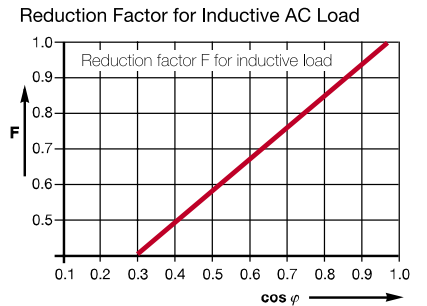
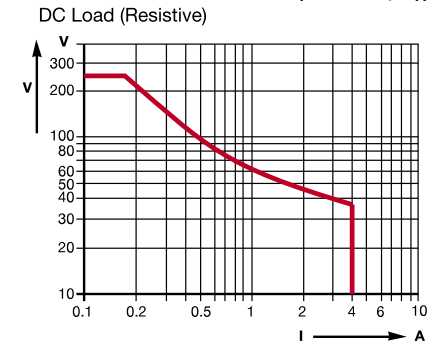
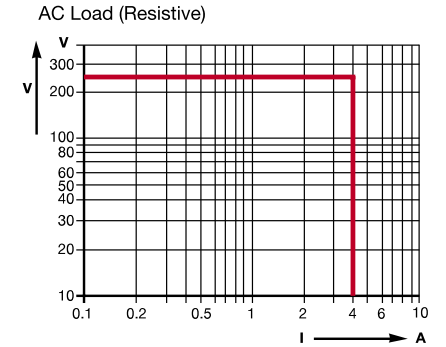

Face View

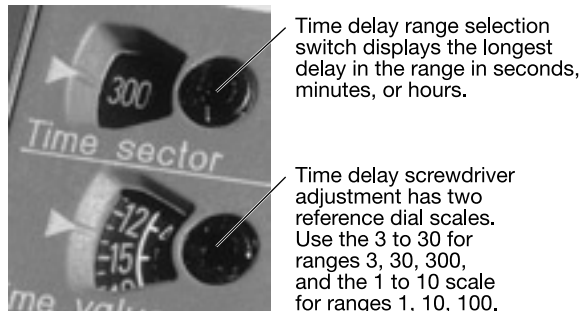
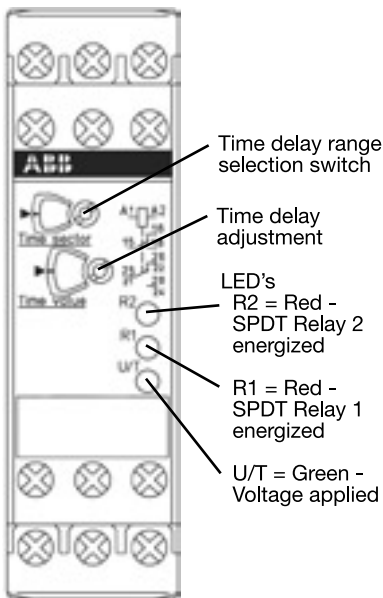

Star Delta (Delay on Make NC/Delay on Make) CT-SDE Timer Relay Output



- Delay On Make NC and Delay On Make
- 1 n/c Contact, 1 n/o Wired Internally
- 2 LED's to Indicate Status
- 3 Voltage Versions, 24 V AC/DC, 220...240 V AC or 110...130 V AC, or 380...415 V AC
- ≤ 1% Repeat Accuracy
- 0.3...30 s Start Delay Range
- Thumb Wheel Adjustment

5

Approvals: US LISTED

Accessories



See accessory pages for specifications.

Operation

Star Delta Starting (DOM N.C.-DOM): Requires connection as shown in the Control Circuit Diagram. The CT-SDE is used for Star-Delta starting of three phase squirrel cage motors. Upon application of supply voltage the Star contactor K1 is energized and the TD1, delay on make startup delay begins. The supply voltage contactor K2 is energized by auxiliary contacts of K1 and then latches ON through its own contacts 13/14 & 53/54. The CT-SDE output relay K1T is de-energized during the startup delay. At the end of the startup delay, the T1K output contacts 15/16 open de-energizing K1 and a fixed 50 ms changeover delay TD2 begins. At the end of the changeover delay the K1T normally open 15/18 contacts close energizing K3 allowing the motor to run with a Delta connection.

Reset: Disconnect supply voltage to the K2 contactor.

LED Operation	Green LED	Red LED
Voltage Applied	ON	N/A
Relay Energized	ON	ON
Reset	OFF	OFF

Connection

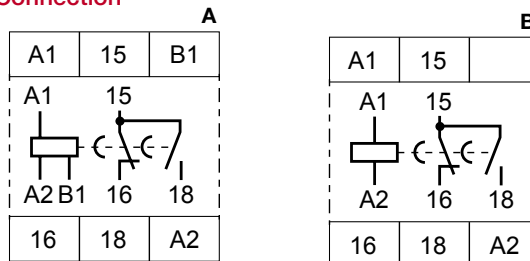

B1-A2 = 24 V AC/DC
A1-A2 = 220...240 V AC

110...130 V AC and
380...415 V AC

Control Circuit Diagram

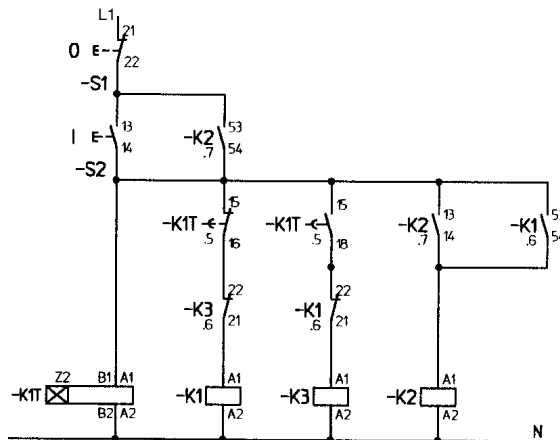

Ordering Table

Supply Voltage	Connection	Part Number
24 V AC/DC, 220...240 V AC	A	1SVR 550 217 R 4100
110...130 V AC	B	1SVR 550 210 R 4100
380...415 V AC	B	1SVR 550 211 R 4100

Function

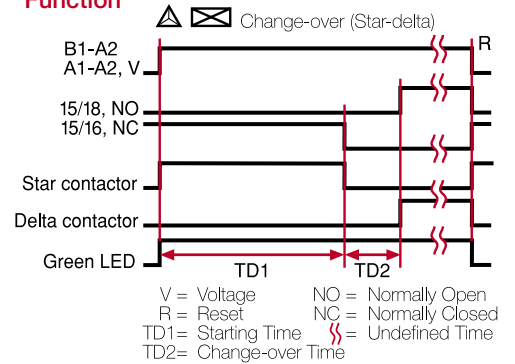

V = Voltage NO = Normally Open
R = Reset NC = Normally Closed
TD1 = Starting Time ∞ = Undefined Time
TD2 = Change-over Time

Power Circuit Diagram

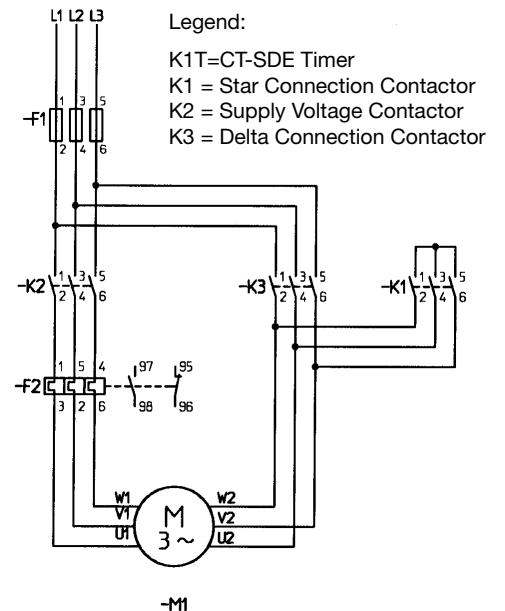

Star Delta (Delay on Make NC/Delay on Make) CT-SDE Timer Relay Output

Technical Data

Input		
Supply voltage - power consumption	A1-A2	24 V AC/DC - approx. 2.0 VA
	A1-A2	110...130 V AC - approx. 2.0 VA
	A1-A2	220...240 V AC - approx. 2.0 VA
	A1-A2	380...415 V AC - approx. 2.0 VA
Tolerance of the supply voltage		-15 % ... +10 %
Supply voltage frequency		50...60 Hz
Duty time		100%
Time Delay		
Time range		0.3...30 s
Reset time		≤ 400 ms
Repeat accuracy (constant parameters)		≤ 1.0 %
Timing error over the supply voltage range		≤ 0.5 %
Timing error over the temperature range		≤ 0.1 % / °C
Star delta change-over time		30 ms
Display of operational status		
Supply voltage		LED green
Output relay energized		LED red
Output		Relay, 1 SPDT contact
Rated voltage	15-16/18 VDE 0100, IEC947-1	250 V
Switching voltage max.		240 V AC
Rated switching current	AC 12 (resistive)	4 A (at 230 V)
IEC 947-5-1	AC 15 (inductive)	3 A (at 230 V)
	DC 12 (resistive)	4 A (at 24 V)
	DC 13 (inductive)	2 A (at 24 V)
Maximum mechanical life		30 x 10 ⁶ operations
Maximum electrical life (to AC 12 / 230 V / 4A)		1 x 10 ⁵ operations
Short-circuit proof, max. fuse rating		10 A / Fast Acting
Opening time		20 ms
General data		
Rated impulse voltage withstand Vimp		4 kV
Operating temperature range		-20°C ... +60°C
Storage temperature range		-40°C ... +85°C
Installation position		Any
Mounting on 35 mm DIN rail (EN 50022)		Snap-on/Screw mounting with an adapter
Wire size, stranded with wire end ferrules		2 x 16 AWG (2 x 1.5 mm ²)
Weight		Approx. 2.8 oz (80 g)
Dimensions (W x H x D)		22.5 x 78 x 78.5 mm

Load Limit Curves

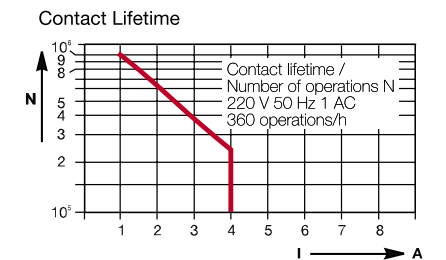
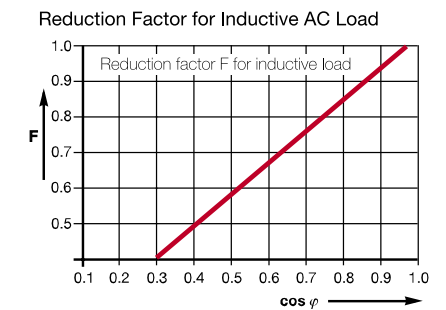
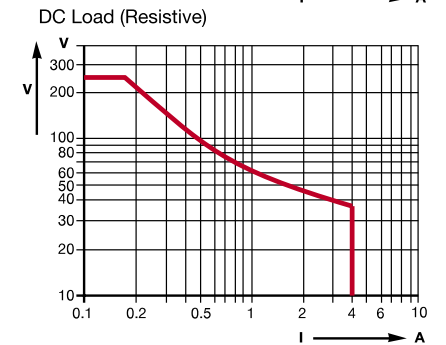
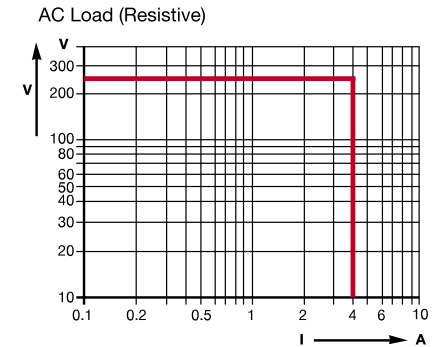

Mechanical View

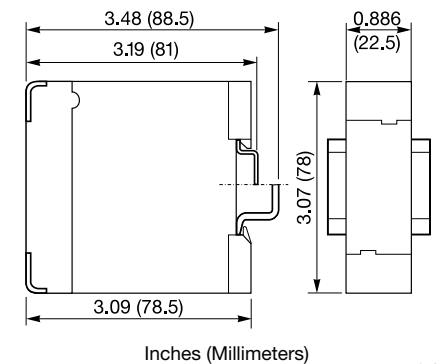

Face View

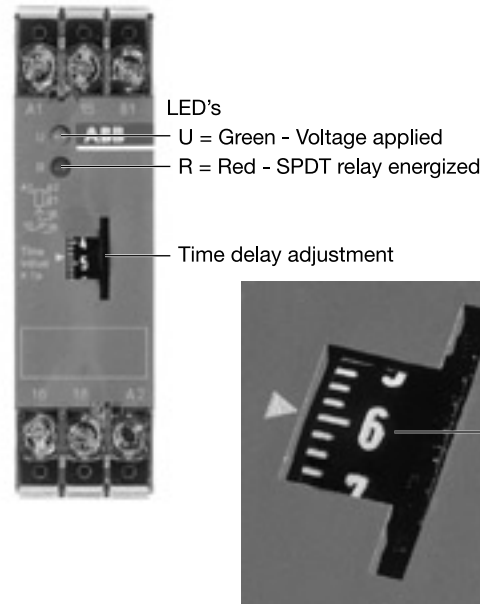

Star Delta (Delay on Make/Interval) CT-YDE Timer Relay Output

5



- Delay on Make/Interval
- Designed for Star-delta Starting
- 3 Time Ranges for a Variable Start-up
- 1 SPDT Contact
- 2 LED's to Indicate Status
- 2 Voltage Versions
24 V AC/DC
220...240 V AC or
110...130 V AC
- ≤ 1% Repeat Accuracy
- Thumb Wheel Adjustment
- 0.1...300 s Start Delay in
3 Ranges

Approvals: us LISTED

Accessories



See accessory pages for specifications.

Operation

Star Delta Starting (DOM-Interval): Requires connection as shown in the Control Circuit Diagram. The CT-YDE is used for Star-Delta starting of three phase squirrel cage motors. Upon application of supply voltage the Star contactor K1 is energized and the TD1, delay on make startup delay begins. The supply voltage contactor K2 is energized by auxiliary contacts of K1 and then latches ON through its own contacts 13/14. The CT-YDE output relay K1T is de-energized during the startup delay. At the end of the startup delay, the CT-YDE output relay 16/15 energizes and a fixed 50 ms changeover delay, TD2 begins. When T1K 15/16 opens it disconnects voltage to itself and Star contactor K. At the end of the changeover delay the output relay 15/16 de-energizes and energizes the K3 Delta contactor allowing the motor to run with a Delta connection.

Reset: Disconnect supply voltage to the K2 contactor.

LED Operation	Green LED	Red LED
Voltage Applied	ON	N/A
Relay Energized	ON	ON
Reset	OFF	OFF

Control Circuit Diagram

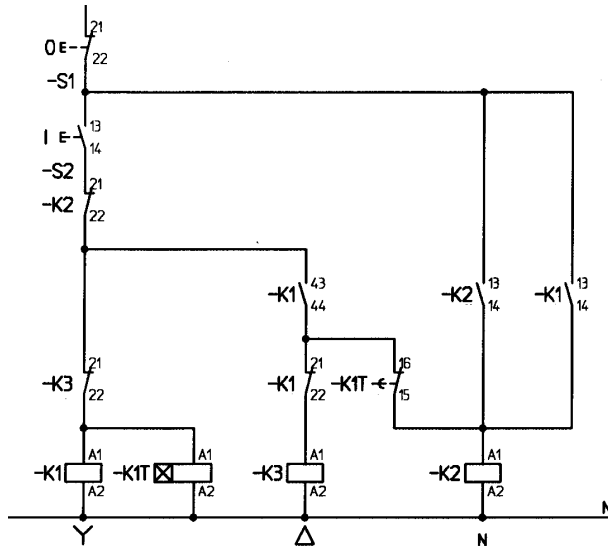

Ordering Table

Supply Voltage	Time Range	Part Number
24 V AC/DC, 220...240 V AC	0.1...10 s	1SVR 550 207 R 1100
	0.3...30 s	1SVR 550 207 R 4100
	3...300 s	1SVR 550 207 R 2100
110...130 V AC	0.1...10 s	1SVR 550 200 R 1100
	0.3...30 s	1SVR 550 200 R 4100
	3...300 s	1SVR 550 200 R 2100

Function

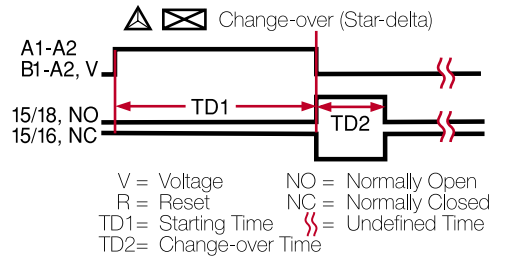

Connection

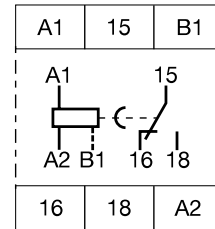

Power Circuit Diagram

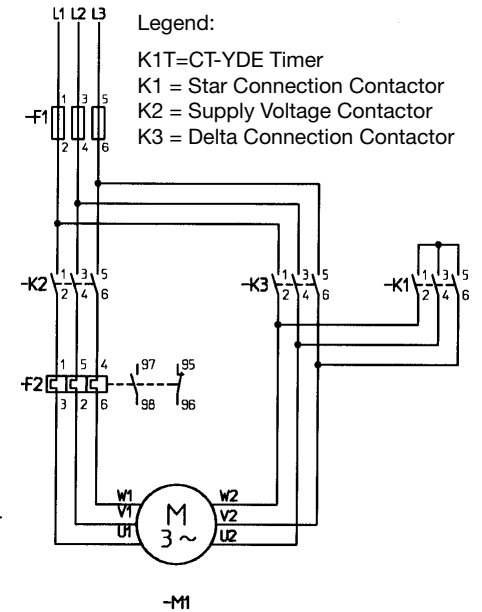

Star Delta (Delay on Make/Interval) CT-YDE Timer Relay Output

Technical Data

Input		
Supply voltage - power consumption	B1-A2 A1-A2 A1-A2	24 V AC/DC - 1.0 VA / W 110...130 V AC - 2.0 VA 220...240 V AC/DC - 2.0 VA
Tolerance of the supply voltage		-15 % ... +10 %
Supply voltage frequency		50...60 Hz
Time Delay		
Time ranges		0.1...10 s, 0.3...30 s, 3...300 s
Reset time		≤ 500 ms
Repeat accuracy (constant parameter)		≤ 1.0 %
Timing error over the supply voltage range		≤ 0.5 %
Timing error over the temperature range		≤ 0.1 % / °C
Star-delta changeover time		50 ms
Display of operational status		
Supply voltage		LED green
Output relay energized		LED red
Output		
Rated voltage	15-16/18 VDE 0100, IEC947-1	Relay, 1 SPDT contact 250 V
Switching voltage max.		240 V AC
Rated switching current	AC 12 (resistive) AC 15 (inductive) DC 12 (resistive) DC 13 (inductive)	4 A (at 230 V) 3 A (at 230 V) 4 A (at 24 V) 2 A (at 24 V)
Maximum mechanical life		30 x 10 ⁶ operations
Maximum electrical life (to AC 12 / 230 V / 4A)		1 x 10 ⁵ operations
Short-circuit proof, max. fuse rating		10 A / Fast Acting
Opening time		≤ 20 ms
General data		
Rated impulse voltage withstand Vimp		4 kV
Operating temperature range		-20°C ... +60°C
Storage temperature range		-40°C ... +85°C
Installation position		Any
Mounting on 35 mm DIN rail (EN 50022)		Snap-on/screw mounting with an adapter
Wire size, stranded with wire end ferrule		2 x 16 AWG (2 x 1.5 mm ²)
Weight		Approx. 2.8 oz (80 g)
Dimensions (W x H x D)		22.5 x 78 x 78.5 mm

Load Limit Curves

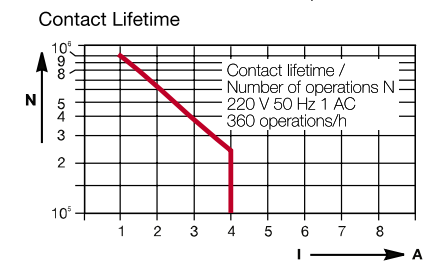
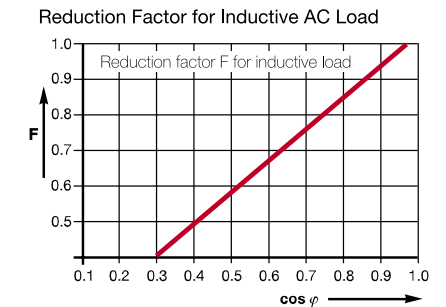
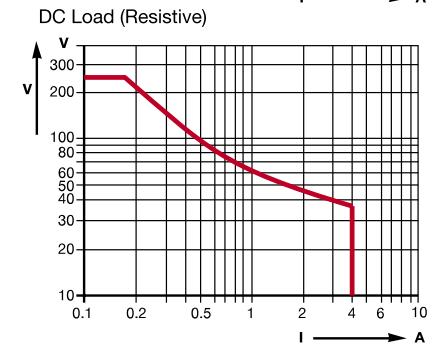
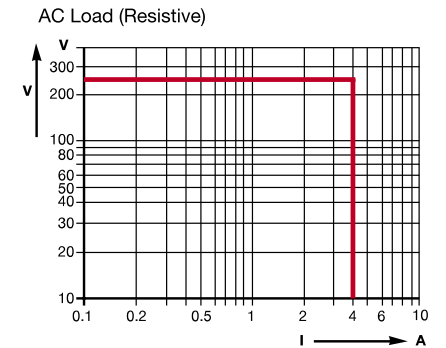

Mechanical View

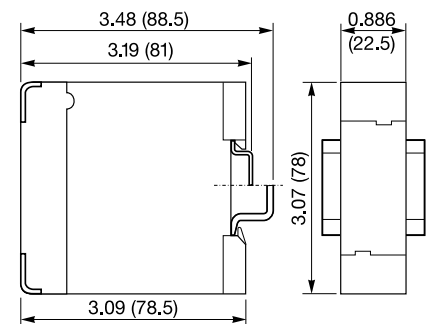

Face View

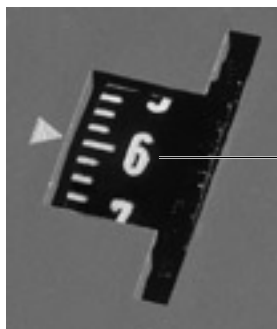
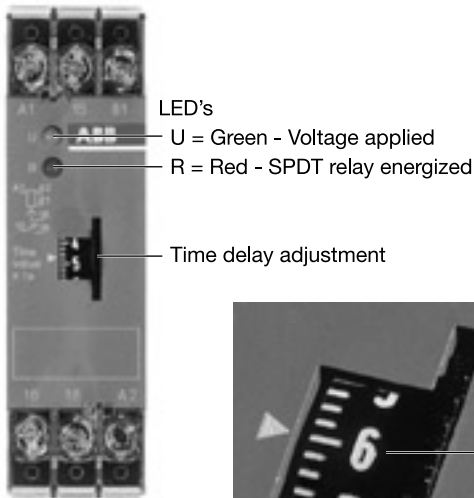



Low Voltage Products & Systems

ABB Inc.
1206 Hatton Road
Wichita Falls, TX 76302
Tel. 888-385-1221
940-397-7000
Sales Fax 800-726-1441
Tech Fax 940-397-7085
Web www.abb-control.com

SSAC
ABB Inc.
PO Box 1000
Baldwinsville, NY 13027
Tel. 315-638-1300
Tech. Asst. 800-377-SSAC (7722)
Fax 315-638-0333
Data Fax 315-638-7158
Web www.ssac.com

ABB Inc
3299, J.B. Deschamps
Lachine, QC H8T 3E4
Canada
Tel: 800-567-0283 (Quebec Head Office)
866-460-3300 (Ontario)
866-222-8368 (Calgary)
604-777-5477 (British Columbia)