

# Universal Lamp Alarm Relay SCR9L LED Beacon & Obstruction Lamps



- Monitors LED Lamps for Failure
- Senses Failed Flashing or Steady Beacon or Obstruction Lamps
- Switch Selectable Number, of Lamps
- 10 A Isolated SPDT Alarm Output Contacts
- 5 A N.O. Line Voltage Alarm Output
- Self Calibrating; No Fine Adjustment required
- Meets FA-AC No: 150/5345-43E

## Description

Preliminary Data Sheet-Available 1st Quarter 2007

The SCR series is a Universal Lamp Alarm Relay designed to sense the failure of flashing or steady LED beacon lamps or obstruction lamps. The SCR Series energizes when one or more lamps fail. It will monitor the operation of one to eight beacon or obstruction lamps. All monitored lamps must be the same wattage and voltage. When connected to a site monitoring system, it provides the remote lamp monitoring protection required by the FAA-AC No: 150/5345-43E.

## Operation

When a lamp fails, the SCR Series senses a decrease in current flow. After a 10 s trip delay, the onboard LED glows and the two alarm outputs energize. The outputs and the LED are reset when the failed lamps are replaced and the unit is recalibrated. The SCR will sense an open flasher, it will not sense a continuously ON flasher (see FB Series). Removing input voltage de-energizes the output and the LED's. It does not change the calibration

## Connection

Beacon Connection Diagram

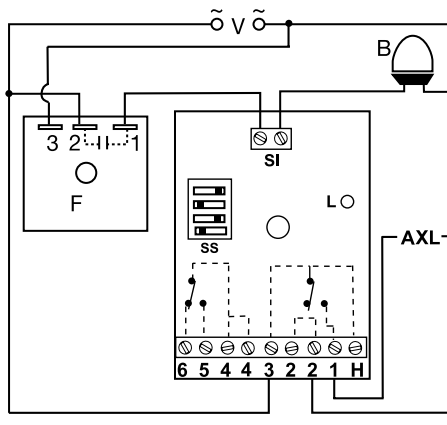

Obstruction Lamp Connection Diagram

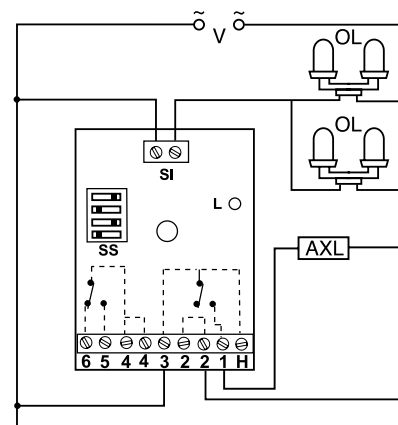

## Indicator Table

L	Green	Input ON & Calibrated
L	Green Flashing	Trip Delay
L	Red	Lamp Failure
L	Red/Green Flashing	Calibrating
L	Red Flashing	Not Calibrated

Dashed lines are internal connections.

V = Voltage B = Beacon Lamps  
SS = Selector Switch L = LED Indicator  
F = Flasher AXL = Auxiliary Load/Alarm  
OL = Obstruction Lamps SI = Sensor Input  
H = "3" Spare AC Hot Connection (2 A Max)

## Adjustment Example:

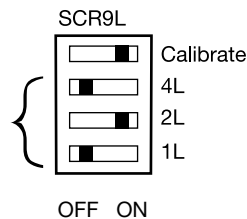

Example Shown: SCR9L two lamps are ON during normal operation.

## Adjustment Table

Total Lamps	Switches ON
1(!)	1L
2	2L
3	1L + 2L
4	4L
5	1L + 4L
6	2L + 4L
7	1L + 2L + 4L
8	None

(!) See Note f on next page

## Ordering Table

Input	Lamp Types	Part Number
120 ... 230 V AC	LED	SCR9L

## Accessories



DIN Mount Adaptor  
P/N: P1023-20



For 35mm  
DIN3 Rail

See Accessory Pages for Specifications

# Universal Lamp Alarm Relay SCR9L LED Beacon & Obstruction Lamps

Tower &  
obstruction  
lighting

## Technical Data

<b>Sensors</b>	
Calibration Range (total all Lamps)	150 mA ... 8.0 A
Absolute Max Current (total all Lamps)	15 A Max. (May not calibrate above 8 A)
Single Lamp Current	150 mA ... 8.0 A (total all Lamps ≤ 8.0 A)
<b>Time Delay</b>	
Trip Delay	Factory fixed ≅ 10 s
<b>Input</b>	
Input Voltage/Tolerance/Frequency	120 ... 230 V AC +/-15% 50 ... 60 Hz
<b>Output</b>	
Line Voltage Output (SPNO)	To operate a spare lamp or alarm
Isolated Alarm Output (SPDT)	5 A at 240 V AC or 30 V DC resistive; 1/4 hp at 125 V AC; 1/2 hp at 250 V AC
Auxilliary Input Voltage (H)	10 A at 240 V AC or 30 V DC resistive; 1/4 hp at 125 V AC; 1/2 hp at 250 V AC
	≤ 2 A at 230 V AC
<b>Mechanical</b>	
Mounting	One #10 (M5 x 0.8) screw
Termination	IP20 Screw Terminals for up to 14 AWG (2.45 mm <sup>2</sup> ) wire or two 16 AWG (1.3 mm <sup>2</sup> ) wires
Package	3 x 2 x 1.64 in (76.7 x 51.3 x 41.7 mm)
<b>Protection</b>	
Circuitry	Encapsulated
<b>Environmental</b>	
Operating / Storage Temperature	-40°C ... +60°C / - 40°C ... +85°C
Weight	≅ 3.9 oz (111 g)

## Calibration

The alarm relays must be calibrated after initial installation and each time the LED lamps are replaced. In order to calibrate or re-calibrate the alarm relay, the internal memory must be cleared.

### Clearing Memory:

Remove input voltage, transfer the calibration switch to the off position, re-apply input voltage. The LED will flash Red to indicate the memory is clear and the relay is ready for calibration.

### Calibration:

- 1) Perform visual inspection of the structure's lighting to assure all lamps and flashers (if used) are operating properly.
- 2) Remove input voltage, and check to ensure the calibrate switch is in the OFF position. Adjust the lamp selector switches for the correct number of similar (see note a) lamps to be monitored.
- 3) Reapply input voltage, the LED should flash Red. After confirming the LED is flashing Red and the lamp selector switches are properly adjusted, transfer the calibrate switch from OFF to ON. The LED will alternately flash Red & Green. Within 30 seconds the LED will glow Green indicating input power is applied and the unit is calibrated. Leave the calibrate switch in the ON position. Reapplying input voltage when this switch is in the ON position does not affect the calibration settings.

### Calibration Failed:

- 4) If the relay is unable to establish trip points for the setup conditions within 60 seconds, the LED will double blink Red. Remove input voltage and repeat steps 2 and 3.

### Notes:

- a. Monitoring a mixture of LED beacons and LED obstruction lamps is not possible with the SCR9L.
- b. This alarm relay is not designed to monitor incandescent lamps.
- c. This alarm relay must be recalibrated each time an LED lamp is replaced.
- d. Due to LED lamp aging, recalibration every 12 months is recommended.
- e. Applying input voltage when the calibrate switch is in the OFF position, erases the previous calibration settings. The LED will flash Red. The output relays are OFF and the unit will not sense lamp failures.
- f. Only one temperature compensated LED Beacon can be monitored with this product. A combination of temperature compensated and standard LED Beacons cannot be monitored.

## Mechanical View

