

Universal Lamp Alarm Relay

FB9L

LED Beacons



- Senses Failed Flashing Beacon Lamps
- Switch Selectable Number, of Beacons
- Senses Flasher Failure
- 10 A Isolated SPDT Alarm Output Contacts
- 10 A N.O. Line Voltage Alarm Output
- 0.5 A Solid State Flasher Failure Output "F"
- Self Calibrating; No Fine Adjustment Required
- Meets FAA-AC No: 150/5345-43E

Description

Preliminary Data Sheet-Available 1st Quarter 2007

The FB series is a Universal Lamp Alarm Relay designed to sense the failure of flashing LED beacon lamps. It will monitor the operation of one to eight beacons connected to a single flasher and/or auxiliary modules and the operation of the flasher. The FB Series output relay energizes when one or more lamps fail. All monitored lamps must be the same wattage and voltage. The 0.5 A solid state output energizes when a flasher failure is sensed.

Operation

When a LED beacon lamp fails, the FB senses a decrease in current flow. After a 10 s lamp failure trip delay, the isolated SPDT (4-5-6) and non-isolated SPNO (3-1) relay contacts energize. These contacts are used to indicate a beacon failure has occurred. The "L" onboard LED indicator flashes green during the trip delay and glows red after the output relay energizes. Connected to a site monitoring system, it provides remote beacon monitoring required by FAA-AC No: 150/5345-43E.

The FB also monitors the operation of the flasher. If the flasher remains in the ON or OFF condition for more than 6 s the solid state output energizes and the "F" flasher failure, onboard LED glows Red. This output is normally used to energize an external flasher bypass relay. The contacts of the bypass relay are used to route voltage around the failed flasher and to indicate an alarm condition.

Note: In a single flasher, single beacon system, if the beacon lamp fails, zero current flow is detected. This will cause the flasher failure output to energize after 6 s and then the beacon failure outputs after 10s. This is normal operation and can be expected anytime zero current is flowing through the monitored conductor.

Connection

Beacon Connection Diagram

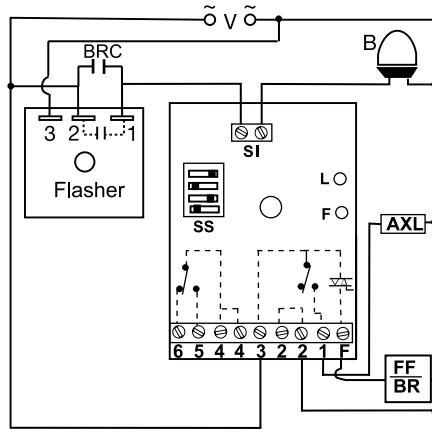

Adjustment Example:

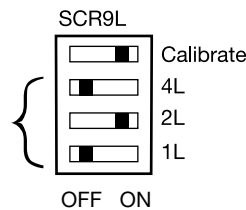

Example Shown: FB9L two lamps are ON during normal operation.

Indicator Table

L	Green	Input ON & Calibrated
L	Green Flashing	Trip Delay
L	Red	Lamp Failure
L	Red/Green Flashing	Calibrating
L	Red Flashing	Not Calibrated
F	Red	Flasher Failure

Dashed lines are internal connections.

V = Voltage B = LED Beacon SS = Selector Switch
 SI = Sensor Input L = Indicator
 F = Flasher Failure LED AXL = Auxiliary Load/Alarm
 FF = Flasher Failure/Bypass Relay
 BRC = Bypass Relay Contacts

Adjustment Table

Total Lamps	Switches ON
1(!)	1L
2	2L
3	1L + 2L
4	4L
5	1L + 4L
6	2L + 4L
7	1L + 2L + 4L
8	None

(!) See Note f on next page

Accessories



DIN Mount Adaptor
 P/N: P1023-20



For 35mm DIN3 Rail

See Accessory Pages for Specifications

Ordering Table

Input	Beacon Type	Part Number
120 ... 230 V AC	LED	FB9L

Universal Lamp Alarm Relay

FB9L

LED Beacons

Tower &
obstruction
lighting

Technical Data

Sensors	
Calibration Range (total all Lamps)	150 mA ... 8.0 A
Absolute Max Current (total all Lamps)	15 A Max. (May not calibrate above 8 A)
Single Lamp Current	150 mA ... 8.0 A (total all Lamps \leq 8.0 A)
Trip Delay	
Flasher Failure	Fixed at 6 s; -0/+40%
Lamp Failure	Fixed at 10 s; -0/+40%
Input	
Input Voltage/Tolerance/Frequency	120 ... 230 V AC +/-15% 50 ... 60 Hz
Output	
Line Voltage Output (SPNO)	To operate a spare lamp or alarm 5 A at 240 V AC or 30 V DC resistive; 1/4 hp at 125 V AC; 1/2 hp at 250 V AC
Isolated Alarm Output (SPDT)	10 A at 240 V AC or 30 V DC resistive; 1/4 hp at 125 V AC; 1/2 hp at 250 V AC
Solid State Line Voltage Output (F)	0.5 a steady; 5 A inrush
Mechanical	
Mounting	One #10 (M5 x 0.8) screw
Termination	IP20 Screw Terminals for up to 14 AWG (2.45 mm ²) wire or two 16 AWG (1.3 mm ²) wires
Package	3 x 2 x 1.64 in (76.7 x 51.3 x 41.7 mm)
LEDs	
Power/Timing/Lamp Failure (Bi color)	Glows Red when one or more lamps fail (See LED Table)
Flasher Failure (Red)	Glows Red when the flasher fails
Protection	
Circuitry	Encapsulated
Environmental	
Operating / Storage Temperature	-40°C ... +60°C / -40°C ... +85°C
Weight	\cong 3.9 oz (111 g)

Calibration

The alarm relays must be calibrated after initial installation and each time the LED lamps are replaced. In order to calibrate or re-calibrate the alarm relay, the internal memory must be cleared.

Clearing Memory:

Remove input voltage, transfer the calibration switch to the off position, re-apply input voltage. The LED will flash Red to indicate the memory is clear and the relay is ready for calibration.

Calibration:

- 1) Perform visual inspection of the structure's lighting to assure all lamps and flashers are operating properly.
- 2) Remove input voltage, and check to ensure the calibrate switch is in the OFF position. Adjust the lamp selector switches for the correct number of similar (see note a) lamps to be monitored.
- 3) Reapply input voltage, the LED should flash Red. After confirming the LED is flashing Red and the lamp selector switches are properly adjusted, transfer the calibrate switch from OFF to ON. The LED will alternately flash Red & Green. Within 30 seconds the LED will glow Green indicating input power is applied and the unit is calibrated. Leave the calibrate switch in the ON position. Reapplying input voltage when this switch is in the ON position does not affect the calibration settings.

Calibration Failed:

- 4) If the relay is unable to establish trip points for the setup conditions within 60 seconds, the LED will double blink Red. Remove input voltage and repeat steps 2 and 3.

Notes:

- a. Monitoring a mixture of LED beacons and LED obstruction lamps is not possible with the SCR9L.
- b. This alarm relay is not designed to monitor incandescent lamps.
- c. This alarm relay must be recalibrated each time an LED lamp is replaced.
- d. Due to LED lamp aging, recalibration every 12 months is recommended.
- e. Applying input voltage when the calibrate switch is in the OFF position, erases the previous calibration settings. The LED will flash Red. The output relays are OFF and the unit will not sense lamp failures.
- f. Only one (1) temperature compensated LED Beacon can be monitored with this product. A combination of temperature compensated and standard LED Beacons cannot be monitored.

Mechanical View

