

**ADVANCES AND NEW DIRECTIONS IN PLANT-WIDE CONTROLLER PERFORMANCE ASSESSMENT****Nina F. Thornhill\* and Alexander Horch+**

*\*Department of Electronic and Electrical Engineering, UCL, UK  
+ABB Corporate Research Centre, Ladenburg, Germany*

**Abstract:** This article reviews advances in detection and diagnosis of plant-wide control system disturbances in chemical processes and discusses new directions that look promising for the future. Causes of plant-wide disturbances include non-linear limit cycles in control loops, controller interactions and tuning problems. The diagnosis of non-linearity, especially when due to valve stiction, has been an active area. Detection of controller interactions and disturbances due to plant structure remain open issues, however, and will need new approaches. For the future, the linkage of data-driven analysis with a qualitative model of the process is an exciting prospect that now looks within reach. Finally, the paper offers some comments about emerging applications. *Copyright © 2006 IFAC.*

**Keywords:** fault detection; nonlinear time-series analysis; oscillation, performance analysis; plantwide, process monitoring; process operation.

**1. INTRODUCTION**

Single-input-single-output control loop performance assessment (CLPA) and benchmarking is well established in the process industries [1,2]. The SISO approach has a shortcoming, however, because control loops are not isolated from one another. Specifically, the reason for poor performance in one control loop might be that it is being upset by a disturbance originating elsewhere.

The basic idea of process control is to divert process variability away from key process variables into places that can accommodate the variability such as buffer tanks and plant utilities [3]. Unfortunately, process variability is often *not* accommodated and it may just move elsewhere. The reason for this is that modern industrial processes have reduced inventory and use recycle streams and heat integration. The interactions are strong in such processes because the amount of buffer capacity is small and the opportunities to exchange heat energy with plant utilities are restricted.

A plant-wide approach means that the distribution of a disturbance is mapped out and the location and

nature of the cause of the disturbance is determined with a very high probability of being right first time. The alternative is a time consuming procedure of testing each control loop in turn until the root cause is found. Some key requirements (e.g. see[4]) are:

- Detection of the presence of one or more periodic oscillations;
- Detection of non-periodic disturbances and plant upsets;
- Determination of the locations of the various oscillations/disturbances in the plant and their most likely root causes.

A wish-list from [2] included:

- Automated, non-invasive stick-slip detection in control valves;
- Facility-wide approaches including behaviour clustering;
- Automated model-free causal analysis;
- Incorporation of process knowledge such as the role of each controller.

The paper gives an overview of our own and others' work in detection and diagnosis of plant-wide control system disturbances. Detection of plant-wide disturbances is covered in Section 2 and the isolation

and diagnosis of the root causes in Section 3. Both attempt a logical and structured classification and a comparative review of methods as well as highlighting open issues and unsolved problems. They are illustrated with a case study from a refinery. Section 4 discusses tests for sticking valves while Section 5 describes a new research direction involving the linkage of process information with data driven analysis using computer aided design data. Finally, Section 6 outlines some potential new areas of application.

## 2. PLANT-WIDE DIAGNOSIS

### 2.1 A classification of disturbances

**Timescales:** The first distinction in a classification of plant-wide disturbances concerns the timescale, which may be (a) slowly-developing, e.g. catalyst degradation or fouling of a heat exchanger, (b) persistent and dynamic, and (c) abrupt, e.g. a compressor trip. The focus of this paper is on (b), dynamic disturbances that persist over a time horizon of hours to days. The approach is typically one of process auditing in which a historical data set is analysed off-line. The off-line approach gives opportunities for advanced signal processing methods such as integral transforms and non-causal filtering.

**Oscillating and non-oscillating disturbances.** Figure 1 shows a family tree of methods for the detection of plant-wide disturbances and cites the references. The vertical placements in the tree are of no significance, they have been adjusted in order to make the text fit. The main sub-division is between oscillating and non-oscillating behaviours. An oscillation is clear in both the time domain and as a peak in the frequency domain suggesting that either might be exploited for detection. The time trends of a non-oscillating disturbance often look somehow similar but in a way that is hard to characterize because the localised behaviour is not strongly coordinated. The frequency domain, on the other hand, shows the similarity well and therefore the spectra are exploited for detection of non-oscillating disturbances. Some dynamic disturbances are not stationary. For instance, an oscillation may come and go or may change in magnitude. The localisation in time means wavelet methods should be used for such cases.

### 2.2 Detection of oscillating disturbances

Methods for detection of oscillation fall into three main classes namely those which use the time domain, those using autocovariance function (ACF), and spectral peak detection. Filtering or some other way of dealing with noise is usually needed in the time domain applications. A benefit of using the ACF is that the ACF of random noise appears at zero lag leaving a clean signal for analysis at other lags. All the methods [5-10] should be able to detect the oscillations whose time domain, ACF and spectra are shown in Figure 3.

Most of the methods are off-line and exploit the off-line advantages, such as the use of the whole data set to determine a spectrum or autocovariance function. The oscillation monitor of Hägglund [5] is an on-line method and was implemented industrially in the ECA400 PID controller from Alfa Laval Automation which gave an alarm when an oscillation is detected.

The cited methods in [5-8] and [10] achieve the detection of an oscillation one measurement at a time, but more is needed for plant-wide detection than the detection of oscillations in individual control loops. It requires the recognition that an oscillation in one measurement is the same as the oscillation in another measurement, even though the shape of the waveform may differ and when interferences such as other oscillations are present. A characterization and grouping step is needed as well as oscillation detection. The method in [9] automated the detection of clusters of similar oscillations. An agglomerative classification algorithm from [16] detects the tags within each cluster and issues a report, an example of which is given in Table 1.

### 2.3 Detection of non-oscillating disturbances

Persistent non-oscillatory disturbances are generally characterized by their spectra which may have broadband features or multiple spectral peaks. The plant-wide detection problem requires (a) a suitable distance measure by which to detect similarity and (b) determination and visualization of clusters of measurements with similar spectra.

In spectral principal component analysis (PCA) [11] the rows of the data matrix  $\mathbf{X}$  are the power spectra  $P(f)$  of the signals and a PCA decomposition reconstructs the  $\mathbf{X}$  matrix as a sum over  $p$

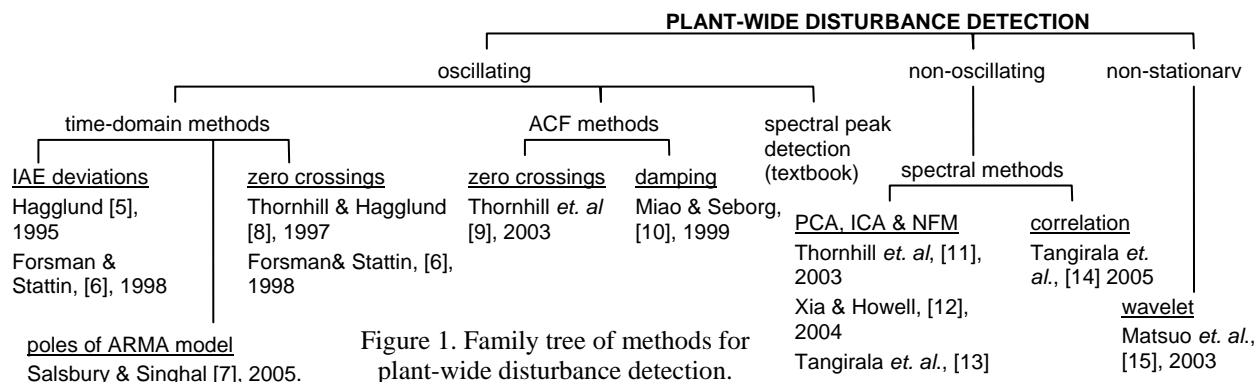

Figure 1. Family tree of methods for plant-wide disturbance detection.

orthonormal basis functions  $\mathbf{w}'_1$  to  $\mathbf{w}'_p$  which are spectrum-like functions each having  $N$  frequency channels arranged as a row vector:

$$\mathbf{X} = \begin{pmatrix} t_{1,1} \\ \dots \\ t_{m,1} \end{pmatrix} \mathbf{w}'_1 + \begin{pmatrix} t_{1,2} \\ \dots \\ t_{m,2} \end{pmatrix} \mathbf{w}'_2 + \dots + \begin{pmatrix} t_{1,p} \\ \dots \\ t_{m,p} \end{pmatrix} \mathbf{w}'_p + \mathbf{E}$$

The  $i$ 'th spectrum in  $\mathbf{X}$  maps to a spot having the coordinates  $t_{i,1}$  to  $t_{i,p}$  in a  $p$ -dimensional space. Similar spectra have similar  $t$ -coordinates and form clusters which can be detected using the Euclidian distance or the angles between lines connecting each spot to the origin. Methods for display include hierarchical tree or a colour map [13]. Independent Component Analysis (ICA) is a decomposition of a data matrix that minimises statistical dependence between the basis vectors. It gives basis functions with a good one-to-one relationship with the physical sources of signals, as shown by Xia and Howell [12] who gave the first application of ICA to process spectra. Non-negative matrix factorization (NMF) was introduced in the area of image recognition [17]. The authors described it as follows: "The basis images for PCA are *eigenfaces* ... which resemble distorted versions of whole faces. The NMF basis ... are localized features that correspond with ... the parts of faces." The first report of the use of NMF for plant-wide disturbance analysis is [13].

#### 2.4 Case study example<sup>1</sup>

The upper panel in Figure 3 plots mean centred and normalized data from the refinery separation unit of Figure 2 showing a large amplitude oscillation in steam flow, analyser and temperature controller errors (*err*) and outputs (*op*) Measurements from upstream and downstream pressure controllers PC1 and PC2 are also included. The lower panel shows the power spectra. The sampling interval was 20s. The steam sensor in FC1 was faulty. Condensate collected on the upstream side of the orifice plate until it reached a critical level, and the accumulated liquid would then periodically clear itself by siphoning through the orifice causing the plant-wide oscillation that can be seen in the data.

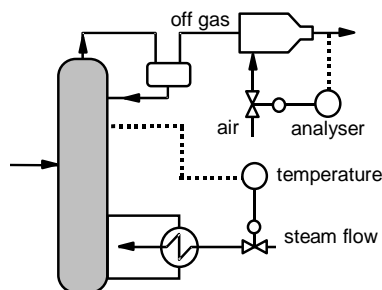

Figure 2. Process schematic.

<sup>1</sup> The methods illustrated in the case study are being productized in a joint ABB/University project [18].

Table 1 gives the results of plant-wide oscillation analysis using [9]. Two plant-wide oscillations are reported because the most regularly oscillating tags in each group (those with the smallest standard deviation) have oscillation periods that are different by more than the standard deviation of either (Tag 4 has  $18.9 \pm 1.5$  and Tag 7 has  $21.1 \pm 1.1$ ).

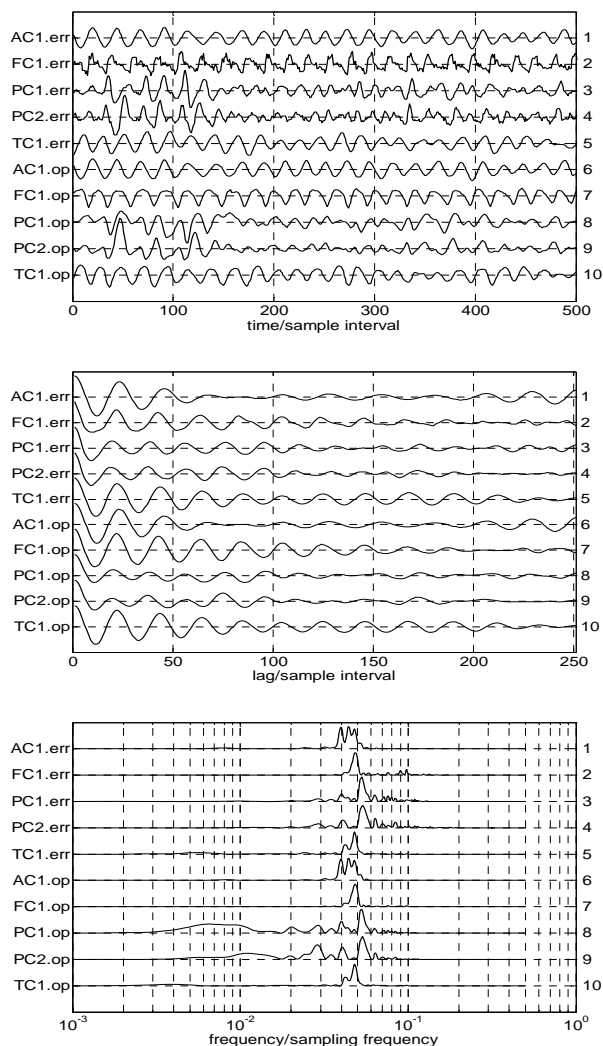

Figure 3. Data set. Upper panel: time trends. Middle panel: ACF. Lower panel: power spectra.

Table 1. Oscillation analysis for the industrial case study.

tag analysis			
tag no	period	tag no	period
1	$20.4 \pm 4.3$	6	$20.4 \pm 4.3$
2	$20.9 \pm 2.5$	7	$21.1 \pm 1.1$
3	$19.1 \pm 1.8$	8	$18.7 \pm 5.5$
4	$18.9 \pm 1.5$	9	$18.9 \pm 3.9$
5	$20.9 \pm 1.1$	10	$20.7 \pm 1.4$
cluster analysis			
period	tags		
18.9	4 3 9 8		
20.7	7 5 10 2 6 1		

The results of spectral principal component analysis are shown in the form of a hierarchical tree in Figure 4 in which the spectrum of each tag is represented as

a square on the horizontal axis. Spectra form a cluster if they are connected to each other by short vertical lines and are well separated from all other spectra. The tree shows Tags 3, 4, 8 and 9 have similar spectra (PC1 and PC2), as do 1, 2, 5, 6, 9, and 10 (FC1, TC1 and AC1). The wide separation of the spectral PCA clusters shows that the groups are distinctly different thus confirming the finding from oscillation analysis. Tags 1 and 6 are the controller error and controller output of AC1. AC1 at the top of the column is physically well separated from FC1 and TC1 (Tags 2, 5, 7 and 10), however, it shares similar dynamic behaviour.

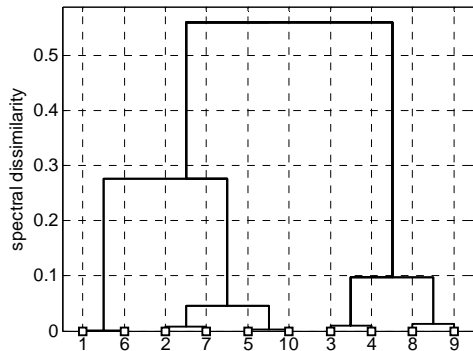

Figure 4 Spectral classification tree.

### 3. ROOT CAUSE DIAGNOSIS

Figure 5 is a family tree of methods for the diagnosis of a plant-wide disturbance. The main distinction is between *non-linear* and *linear* sources. Examples of non-linear sources include:

- Control valves with excessive static friction;
- On-off and split-range control;
- Sensors faults;
- Process non-linearities leading to limit cycles;
- Hydrodynamic instability such as slugging flows.

The diagnosis problem decomposes into two parts. Firstly the root cause of each plant-wide disturbance should be distinguished from the secondary propagated disturbances which will be solved without any further work when the root cause is

addressed. The second stage is testing of the candidate root cause loop to confirm the diagnosis.

#### 3.1 Finding a non-linear root cause of a plant-wide disturbance

Examples of plant-wide disturbances caused by non-linearity were discussed in [21]. They included a faulty steam flow sensor and a hydrodynamic instability caused by foaming in an absorber column. Other examples include the stop-start nature of flow from a funnel feeding molten steel into a rolling mill [37] and variations in consistency of pulp in a mixing process [24]. The point of these examples is to show that disturbances due to non-linearity are not just confined to control valve problems.

**Non-linear time series analysis:** A non-linear time series means a time series that was generated as the output of a non-linear system, and a distinctive characteristic is the presence of phase coupling between different frequency bands. Non-linear time series analysis uses concepts that are quite different from linear time series methods and are covered in the textbook of Kantz and Schreiber [38]. For example, surrogate data are time series having the same power spectrum as the time series under test but with the phase coupling removed by randomization of phases. A key property of the test time series is compared to that of its surrogates and nonlinearity is diagnosed if the property is significantly different in the test time series. Another method of nonlinearity detection uses higher order spectra because these are sensitive to certain types of phase coupling. The bispectrum and the related bicoherence have been used to detect the presence of nonlinearity in process data [19]. Root cause diagnosis based on non-linearity has been reported [20,21,39] on the assumption that the measurement with the highest non-linearity is closest to the root cause.

**Limit cycles and harmonics:** Sustained limit cycles are common in non-linear systems. The waveform in a limit cycle is periodic but non-sinusoidal and therefore has harmonics which can be used to detect non-linearity. It is not always true, however, that the time trend with the largest harmonic content is the

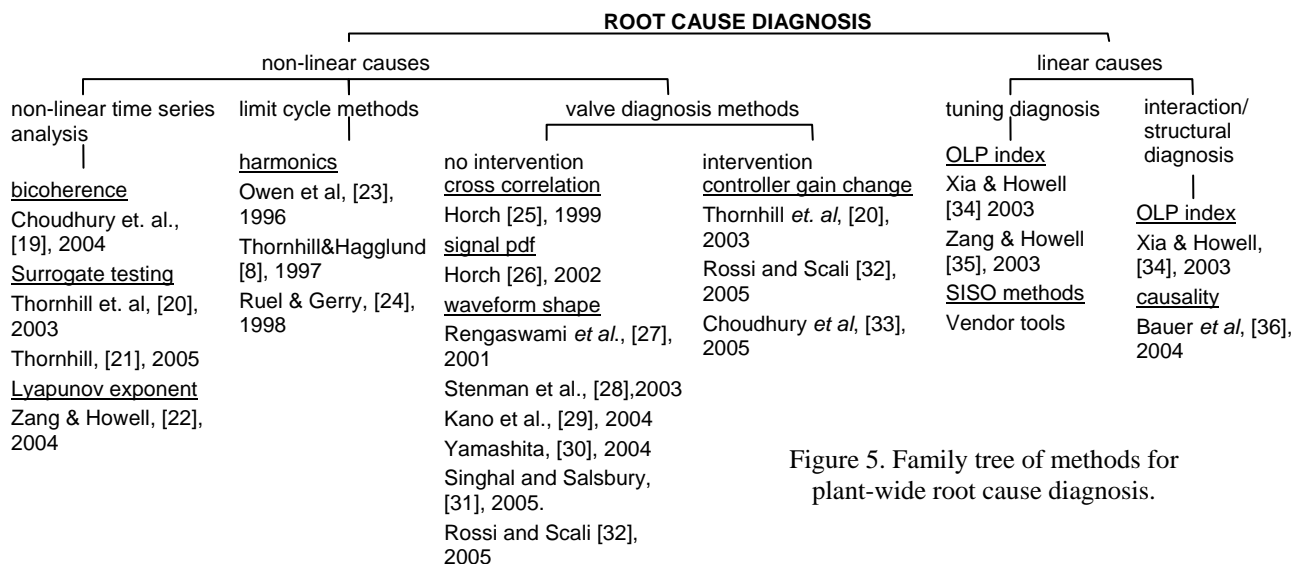

Figure 5. Family tree of methods for plant-wide root cause diagnosis.

root cause. The second and third harmonics of a non-sinusoidal oscillatory disturbance are sometimes amplified in the secondary disturbance when a control loop compensates for higher harmonics in an external disturbance. In that case the harmonic content of the manipulated variable may be higher than that of either the disturbance or the controlled variable, even though non-linearity tests show the manipulated variable to be more linear [40].

**Disturbance propagation:** The reason why the non-linearity is strongest nearest to the source of a disturbance is that the plant acts as a mechanical filter. As the limit cycle propagates to other variables such as levels, compositions and temperatures the waveforms generally become more sinusoidal and more linear because plant dynamics destroys the phase coupling and removes the harmonics. Empirically, non-linearity measures do very well in isolation of non-linear root causes. However, a full theoretical analysis is missing at present of why and how the various measures change as a disturbance propagates, and this remains open research question.

**Case study example:** Non-linearity testing using [21] showed the group of tags in Table 1 with the 21 samples per cycle oscillation period had non-linearity in the FC1 controller output, FC1 controller error and the TC1 controller output which points unambiguously to the FC1 slave control loop as the source of the oscillation. This is the correct result, the FC1 control loop was in a limit cycle because of its faulty steam flow sensor. There was no non-linearity present in tags 3, 4, 8 and 9 associated with PC1 and PC2 and a root cause other than non-linearity has to be sought for their oscillation. A controller interaction is suspected because set point changes in PC1 (not shown) initiated oscillatory transient responses in both pressure controllers.

### 3.2 Finding a linear root cause of a plant-wide disturbance

A poll of industrial process control engineers at a June 2005 IEE Seminar in the UK suggested the most common root causes, after non-linearity, are poor controller tuning, controller interaction and structural problems involving recycles. The detection of poorly tuned loops SISO loops is routine using commercial CLPA tools, but the question of whether an oscillation is generated by the controller or is external has not yet been solved satisfactorily. Promising approaches to date require some knowledge of the transfer function [34].

There has been little academic work to address the diagnosis of controller interaction and structural problems using only data from routine process operations. Some progress in being made, however, by cause and effect analysis of the process signals using a technique that is sensitive to directionality to find the origin of a disturbance [36,41,42]. The methods are sensitive to time delays, attenuation and the presence of noise and further disturbances that affect the propagating signals. The outcome of the

analysis is a qualitative process model showing the causal relationships between variables.

**An example:** The analysis can be a help to an experienced process control engineer who has good knowledge of the process. A joint study between BP and UCL used the method of transfer entropy with data from a process with a recycle, Figure 6. None of the time trends was non-linear and the causal map implicated the recycle because all the variables in the recycle were present in the order of flow. Knowing that the problem involves the recycle rather than originating with any individual control loop suggested the need for an advanced control solution.

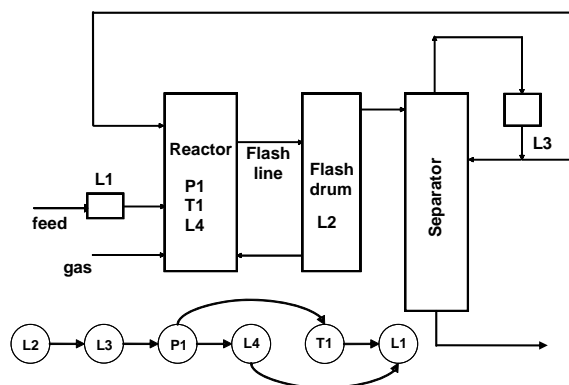

Figure 6. Cause and effect in a process with recycle (courtesy of A. Meaburn and M. Bauer).

## 4. VALVE TESTS

If a root cause has been isolated to a particular part of the plant then further tests are usually carried out before maintenance action is requested. Also, some alleviating actions may be taken to minimise the impact of the problem. Figure 5 cites references for useful methods which have been reviewed in detail elsewhere [43]. Some general observations are discussed here.

**Stiction in valves:** A problem with control valves is the dead band and stick-slip behaviour (stiction) caused by excessive static friction [44]. *Deadband* arises when a finite force is needed before the valve stem starts to move, *stick-slip* behaviour happens when the maximum static friction required to start the movement exceeds the dynamic friction once the movement starts [44, 45, 46;47].

Control valve diagnosis is straightforward if the controller output signal, *op*, and either the flow through the valve, *mv*, or the valve position are measured. A *op-mv* plot is a straight line at 45 degrees for a healthy linear valve, and any deviations such as deadband can be easily diagnosed by visual inspection. Unfortunately the flow through the control valve is frequently *not* measured unless it is in a flow control loop. Similarly, the position, while it may be measured on a modern valve with a positioner, is not always available in the data historian. The challenge in analysis of valve problems, then, is to determine and quantify the type

of fault present using *op* and *pv* data only. The *pv* is the measurement or controlled variable of the control loop, for instance the level in the case of a level control loop. The major difficulty is that the process dynamics (integration in the case of a level loop) greatly interfere with the analysis. It is encouraging that several of the methods reviewed in depth in [43] are able to utilize *op* and *pv* data successfully.

The impact of the controller on the limit cycle: It has been known for many years that control loops with sticking valves do not always have a limit cycle [48,49]. Table 2 lists the behaviour depending on the process, controller and the presence or not of deadband and stick-slip. A short-term solution is to change the controller to *P*-only. The oscillation should disappear in a non-integrating process and while it may not disappear in an integrating process its amplitude will probably decrease.

A further observation is that changing the controller gain changes the amplitude and period of the limit cycle oscillation. In fact, observing such a change is a good test for a faulty control valve [20]. The aim is to reduce the magnitude of the limit cycle in the short term until maintenance can be carried out. In practice, since the expected change in amplitude and period is complicated to work out, one tries a 50% reduction in gain first or a similar increase in gain if the trends seems to be going the wrong way.

Table 2 Limit cycles in control loops.

process and controller	deadband only	stick-slip
integrating, PI	limit cycle	limit cycle
integrating, P-only	no limit cycle	limit cycle
non-integrating, PI	no limit cycle	limit cycle
non-integrating, P-only	no limit cycle	no limit cycle

## 5. USE OF PROCESS INFORMATION

Qualitative process information is implicitly used in diagnosis when an engineer analyses the results from a data-driven analysis. An exciting possibility is to capture and make automated use of such information. Qualitative models include signed digraphs (SDG) [50, 51] and Multilevel Flow Modelling [52]. Chiang and Braatz [53] and also [54] showed enhanced diagnosis using signal based analysis if a qualitative model is available.

We believe that qualitative models of processes will in future become almost as readily available as the historical data. The new technology that will generate such models is already in place in Computer Aided Engineering tools such as ComosPT (Innotec) and Intools (Intergraph). The object-oriented representation of process diagrams can be exported in a text based format that describes equipments and the connections between them. In Europe, the Standard is a (Pre)Norm DIN V 44366:2004-12 called Computer Aided Engineering Exchange (CAEX). ISO-15926-7 is a similar standard.

A prototype tool that links a CAEX description with a data-driven analysis has been demonstrated in a joint project between UCL and ABB. Its aim is to parse and draw conclusions from an electronic process schematic. When linked with data-driven signal analysis of process measurements the end result is a powerful diagnostic tool for isolating the root causes of disturbances. The features are:

- Capture of a process connectivity description using CAEX;
- Parsing and manipulation of the description;
- Linkage of plant description and results from data-driven analysis;
- Testing of root cause hypotheses through falsification;
- Logical tools to give root cause diagnosis and process insights.

The CAEX file describes items of equipment in the plant such as tanks, pipes, valves and instruments and how they are linked together physically and/or through electronic control signals. The data file gives information about the plant disturbances, for instance the period of oscillation, its intensity and regularity, the measurement points where it was detected and any non-linearity detected in the time trends.

A reasoning engine finds physical paths and control paths in the plant and connections between equipments, and determines root causes for plant-wide disturbances. For example, detection of non-linearity in the time series of the process measurements suggests a non-linear root cause such as a sticking valve. In the case of ambiguity then the reasoning engine highlights the one further upstream as the more likely root cause. It can also verify that there is a feasible propagation path between a candidate root cause and all the other locations in the plant where secondary disturbances have been detected. A further capability is to suggest the best proxy measurement point for an unmeasured flow.

## 6. NEW APPLICATION AREAS

Plant-wide detection and diagnosis is starting to have an impact in areas outside process systems such as power plants, supply chains and electricity transmission systems. The techniques map across without difficulty after adjustments for the timescales, for instance inter-area oscillation in electricity transmission typically have periods of 2 to 5 seconds while in manufacturing supply chains the oscillation have periods of weeks to months. The main challenge in successful transfer of the methods is in knowing what faults are typical of the target systems, and the business needs and drivers.

Power plant applications: The heart of the power generation process is a recycle. Power plants are well-equipped with sensors and instrumentation is generally well maintained. Typical disturbances therefore are linear root-causes rather than actuator and instrument problems. The density of instrumentation means that many measurements

share similar disturbance patterns which increases the complexity of the task to be solved. On the other hand, due to the dense instrumentation, it should be possible to locate possible root causes rather exactly.

Supply chain: Business needs include detection and diagnosis of rogue seasonality and demand amplification. Rogue seasonality is oscillation in inventory, orders and deliveries to customers induced by internal business practices. Demand amplification (also known as bullwhip) occurs in multi-echelon chains when replenishment rules magnify small variations in end-customer demands into large amplitude variations for upstream suppliers. Business data are often presented as weekly averages, meaning that only 52 data points are generated per year for each measured variable.

Electricity transmission: A requirement for daily operation is for on-line assessment of the damping status of a transmission network, and methods already exist to do this task. The tools described in this paper are for off-line auditing, nevertheless they have promise for the analysis and diagnosis immediately after an operational problem. Data collection is challenging. One issue is the accurate time-stamping of data collected over a very wide area, another is the compilation of data from different commercial organizations. Generating companies own the measurements of generator speed and rotor angle, while the transmission company owns the voltage, current and bus angle measurements.

## 7. SUMMARY

Section 1 listed some industrial requirements and a wish-list for plant-wide controller performance assessment. The work reviewed in this paper has showed good progress towards these targets especially in detection of plant-wide disturbances and behaviour clustering. Non-linear root causes can now be located and distinguished from the secondary propagated disturbances using analysis of signals from routine operation, with a high chance of being right first time. Stiction detection in valves has had much attention with several methods starting to perform well even in the difficult situation where no manipulated variable is measured. The isolation of linear root causes such as controller interactions and recycle dynamics is an open area still needing attention, however. Finally, we believe the linkage of plant layout information with signal analysis is due to take a big step forward using new Standards for description of plant layouts.

## 8. ACKNOWLEDGMENTS

The first author gratefully acknowledges the support of the Royal Academy of Engineering (Global Research Award) and of ABB Corporate Research.

## 9. REFERENCES

- 1 Qin, S.J. (1998). Control performance monitoring - a review and assessment. *Computers and Chemical Engineering*. **23** 173-186.
- 2 Desborough, L. and R. Miller (2002). Increasing customer value of industrial control performance monitoring – Honeywell's experience. *AICHE Symposium Series* No 326. **98**, 153-186.
- 3 Luyben, W.L., B.D. Tyreus and M.L. Luyben (1999). *Plantwide Process Control*. McGraw-Hill.
- 4 Paulonis, M.A. and J.W. Cox (2003). A practical approach for large-scale controller performance assessment, diagnosis, and improvement. *Journal of Process Control*. **13**, 155-168.
- 5 Hägglund, T. (1995). A control-loop performance monitor. *Control Engineering Practice*. **3**, 1543-1551.
- 6 Forsman, K. and A. Stattin, (1999). A new criterion for detecting oscillations in control loops. *European Control Conference*, Karlsruhe, Germany.
- 7 Salsbury, T.I. and A. Singhal, (2005). A new approach for ARMA pole estimation using higher-order crossings. *Proceedings of ACC 2005*, Portland, USA.
- 8 Thornhill, N.F. and T. Hägglund (1997). Detection and diagnosis of oscillation in control loops. *Control Engineering Practice*. **5**, 1343-1354.
- 9 Thornhill, N.F., B. Huang, and H. Zhang (2003). Detection of multiple oscillations in control loops. *Journal of Process Control*. **13**, 91-100.
- 10 Miao, T. and D.E. Seborg (1999). Automatic detection of excessively oscillatory feedback control loops. *IEEE Conference on Control Applications*. Hawaii, 359-364
- 11 Thornhill, N.F., S.L. Shah, B. Huang, and A. Vishnubhotla (2002). Spectral principal component analysis of dynamic process data. *Control Engineering Practice*. **10**, 833-846.
- 12 Xia, C. and J. Howell (2005). Isolating multiple sources of plant-wide oscillations via spectral independent component analysis. *Control Engineering Practice*. **13**, 1027-1035.
- 13 Tangirala, A.K. and S.L. Shah (2005). Non-negative matrix factorization for detection of plant-wide oscillations. *Submitted to IEEE Transactions on Knowledge and Data Mining*.
- 14 Tangirala, A.K., S.L. Shah and N.F. Thornhill (2005). PSCMAP: A new measure for plant-wide oscillation detection. *Journal of Process Control*. **15**, 931-941.
- 15 Matsuo, T. H. Sasaoka and Y. Yamashita (2003). Detection and diagnosis of oscillations in process plants. *Lecture Notes in Computer Science*. **2773**, 1258-1264.
- 16 Chatfield, C. and A.J. Collins (1980) *Introduction to Multivariate Analysis*. Chapman and Hall, London, UK
- 17 Lee, D.D. and H.S. Seung (1999). Learning the parts of objects by non-negative matrix factorization. *Nature*. **401**, 788-791.
- 18 Horch, A., V. Hegre, K. Hilmen, H. Melbø, L. Benabbas, E.N. Pistikopoulos, N.F. Thornhill and N. Bonavita (2005). Root Cause - Computer-aided plant auditing made possible by successful university cooperation. *ABB Review* 2/2005. [Online: http://www.abb.com/abbreview](http://www.abb.com/abbreview)
- 19 Choudhury, M.A.A.S., S.L., Shah and N.F. Thornhill (2004). Diagnosis of poor control loop performance using higher order statistics. *Automatica*. **40**, 1719-1728.
- 20 Thornhill, N.F., J.W. Cox and M. Paulonis (2003). Diagnosis of plant-wide oscillation through data-driven

- analysis and process understanding. *Control Engineering Practice*. **11**, 1481-1490.
- 21 Thornhill, N.F. (2005). Finding the source of nonlinearity in a process with plant-wide oscillation. *IEEE Transactions on Control System Technology*. **13**, 434-443
  - 22 Zang, X. and J. Howell (2004). Correlation dimension and Lyapunov exponents based isolation of plant-wide oscillations. *DYCOPS 7*, Boston July 5-7.
  - 23 Owen, J.G., D. Read, H. Blekkenhorst and A.A. Roche (1996). A mill prototype for automatic monitoring of control loop performance. *Proceedings of Control Systems 96*, Halifax, Nova Scotia, 171-178.
  - 24 Ruel, M. and J. Gerry (1998). Quebec quandary solved by Fourier transform. *Intech (August)*, 53-55.
  - 25 Horch, A. (1999). A simple method for detection of stiction in control valves. *Control Engineering Practice*. **7**, 1221-1231.
  - 26 Horch, A., 2002, Patents WO0239201 and US2004/0078168
  - 27 Rengaswamy, R., T. Hägglund and V. Venkatasubramanian (2001). A qualitative shape analysis formalism for monitoring control loop performance. *Engineering Applications of Artificial Intelligence*. **14**, 23-33.
  - 28 Stenman, A., F., Gustafsson and K. Forsman (2003). A segmentation-based method for detection of stiction in control valves. *International Journal of Adaptive Control and Signal Processing*. **17**, 625-634.
  - 29 Kano, M., H. Maruta, H. Kugemoto and K. Shimizu (2004). Practical model and detection algorithm for valve stiction. *DYCOPS 7*, Boston, USA, July 5-7.
  - 30 Yamashita, Y. (2004). Qualitative analysis for detection of stiction in control valves. *Lecture Notes in Computer Science*. **3214**, Part II, 391-397.
  - 31 Singhal, A. and T.I. Salsbury (2005). A simple method for detecting valve stiction in oscillating control loops. *Journal of Process Control*. **15**, 371-382.
  - 32 Rossi, M. and C. Scali (2005). A comparison of techniques for automatic detection of stiction: simulation and application to industrial data. *Journal of Process Control*. **15**, 505-514.
  - 33 Choudhury, M.A.A.S., V. Kariwala, S.L. Shah, H. Douke, H. Takada and N.F. Thornhill (2005). A simple test to confirm control valve stiction. *IFAC World Congress 2005*, July 4-8, Praha.
  - 34 Xia, C. and J. Howell (2003). Loop status monitoring and fault localisation. *Journal of Process Control*. **13**, 679-691.
  - 35 Zang, X. and J. Howell (2003). Discrimination between bad turning and non-linearity induced oscillations through bispectral analysis. *Proceedings of SICE Annual Conference*, Fukui, Japan.
  - 36 Bauer, M., N.F. Thornhill and A. Meaburn (2004). Specifying the directionality of fault propagation paths using transfer entropy. *DYCOPS 7 conference*, Boston, July 5-7, 2004.
  - 37 Graebe, S.F., G.C. Goodwin and G. Elsley (1995). Control design and implementation in continuous steel casting. *IEEE Control Systems Magazine*. **15**(4), 64-71.
  - 38 Kantz, H. and T. Schreiber (1997). *Nonlinear Time Series Analysis*. Cambridge University Press.
  - 39 Zang, X. and J. Howell (2005). Isolating the root cause of propagated oscillations in process plants. *International Journal of Adaptive Control Signal Processing*, **19**, 247-265.
  - 40 Matsuo, T., I. Tadakuma and N.F. Thornhill (2004). Diagnosis of a unit-wide disturbance caused by saturation in a manipulated variable, *IEEE Advanced Process Control Applications for Industry Workshop*, Vancouver, April 26-28 2004.
  - 41 Huang, B., N.F. Thornhill, S.L. Shah and D. Shook (2002). Path analysis for process troubleshooting. *Proceedings of AdConIP 2002*, Kumamoto, Japan, 149-154.
  - 42 Schreiber, T. (2000). Measuring information transfer. *Physical Review Letters*. **85**, 461-464.
  - 43 Horch, A. (2006). Benchmarking control loops with oscillations and stiction. In: *Process Control Performance Assessment*. (Ordys, A., Uduehi, D and Johnson, M.A, Eds), Springer, Guildford, UK.
  - 44 Choudhury, M.A.A.S., N.F. Thornhill and S.L. Shah (2005). Modelling of valve stiction. *Control Engineering Practice*. **13**, 641-658.
  - 45 Olsson, H. (1996). *Control Systems With Friction*. PhD thesis, Lund Institute of Technology, Sweden
  - 46 Karnopp, D. (1985). Computer simulation of stick-slip friction in mechanical dynamical systems. *Journal of Dynamic Systems, Measurement, and Control*. **107**, 100-103.
  - 47 Kayihan, A. and F.J. Doyle III (2000). Friction compensation for a process control valve. *Control Engineering Practice*. **8**, 799-812.
  - 48 McMillan, G. K. (1995). Improve control valve response. *Chemical Engineering Progress*. **91**(6), 76-84.
  - 49 Piiipponen, J. (1996). Controlling processes with nonideal valves: Tuning of loops and selection of valves. *Proceedings of Control Systems 96, Halifax, Nova Scotia, Canada*, 179-186.
  - 50 Venkatasubramanian, V., R. Rengaswamy and S.N. Kavuri (2003). A review of process fault detection and diagnosis Part II: Qualitative model and search strategies. *Computers and Chemical Engineering*. **27**, 313-326.
  - 51 Maurya MR, R. Rengaswamy and V. Venkatasubramanian (2004). Application of signed digraphs-based analysis for fault diagnosis of chemical process flowsheets. *Engineering Applications of Artificial Intelligence*. **17**, 501-518.
  - 52 Petersen, J. (2000). Causal reasoning based on MFM. *Proceedings of Cognitive Systems Engineering in Process Control (CSEPC 2000)*, Taejon, Korea, 36-43.
  - 53 Chiang, L.H. and R.D. Braatz (2003). Process monitoring using causal map and multivariate statistics: fault detection and identification. *Chemometrics and Intelligent Laboratory Systems*. **65**, 159-178.
  - 54 Lee GB, S.O. Song, and E.S. Yoon (2003). Multiple-fault diagnosis based on system decomposition and dynamic PLS. *Industrial & Engineering Chemistry Research*. **42**, 6145-6154.