

OVERVIEW

The NGC 8203 Gas chromatograph has a special column set to analyze the components found in low Btu “Landfill” gas. In addition, Totalflow has constructed a sample system that provides a pressurized sample to the NGC from the low pressures typically found in landfill operations.

The low Btu gas is used primarily as fuel for turbines to produce electricity in a “cogen” operation. In some cases the landfill gas is blended with higher Btu components such as propane to raise the quality of the gas and allow it to be fed into a transmission pipeline.

The components typically found in landfill gas are:

- Methane 54%
- Carbon Dioxide 42%
- Nitrogen 3.1%
- Oxygen 0.8%
- Carbon Monoxide (indicating under ground combustion)
- Hydrogen Sulfide less than 1200 ppm

Stream Composition and ranges for a valid application for the NGC C3+ Analysis:

- | • Component | Mol% |
|--------------------|-----------|
| • Nitrogen | 0.1-100 |
| • Carbon Dioxide | 0.1-100 |
| • Methane | 0.05-100 |
| • Ethane | 0.1-100 |
| • Propane | 0.05-100 |
| • Hydrogen Sulfide | 0.01-0.12 |
| • Oxygen | 0.2- 20.0 |
| • Carbon Monoxide | 0.2 -100 |
| • Hydrogen | 0.5-100 |
| • Ethylene | 0.1-100 |

RECOMMENDED SAMPLE CONDITIONING SYSTEM FOR LANDFILL APPLICATION

This sample system is designed to bring the low pressure landfill gas to the NGC at an increased pressure (10-20 psig) for injection into the analyzer. The pressure is increased by a Di-Vac pump. The operator can adjust the inlet stream to an appropriate level of around 15 psig. Most of the sample stream will be vented through the back pressure regulator. It can be vented to atmosphere or returned to the process stream since it is at a higher pressure. The sample stream is also passed through a sample conditioning module which insures that the NGC will be provided with dry, uncontaminated gas for the analysis.



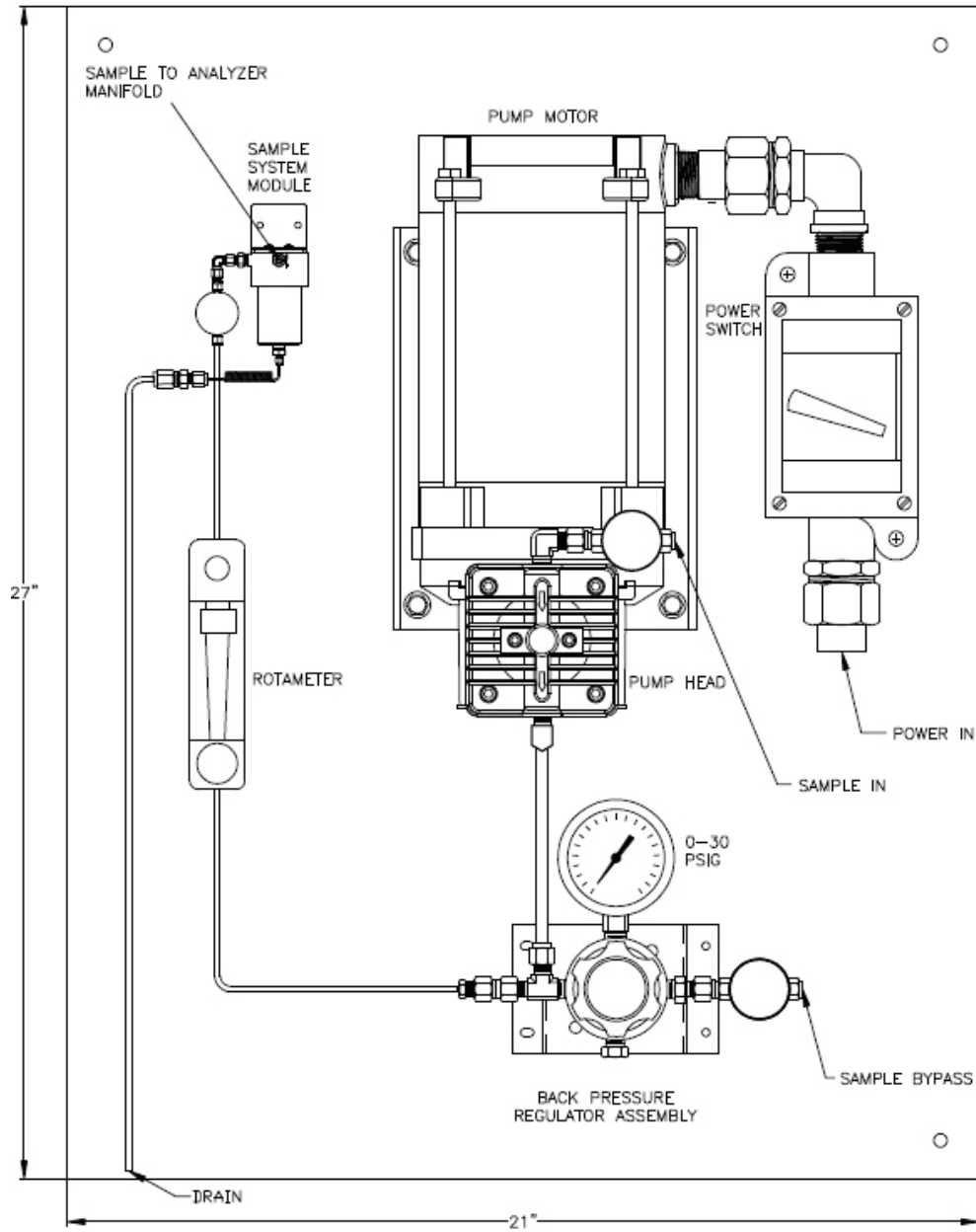

Power and Productivity
for a Better World.™

www.abb.com/totalflow
www.abb.us
www.abb.com



ABB Inc.
Totalflow Products
7051 Industrial Blvd.
Bartlesville, OK 74006
Tel: (918) 338-4888
Fax: (918) 338-4699
(800) 442-3097

For more information,
please contact your
local ABB Totalflow
representative or visit
our website.