

November 2010

Azipod[®] XO

Azipod Propulsion System Features



- Electric Propulsion System
- High Efficiency
- Excellent Manoeuvrability
- Increased Transportation Capacity
- About 6 million operating hours
- (Nov.2010)

Azipod[®] XO System is designed to provide

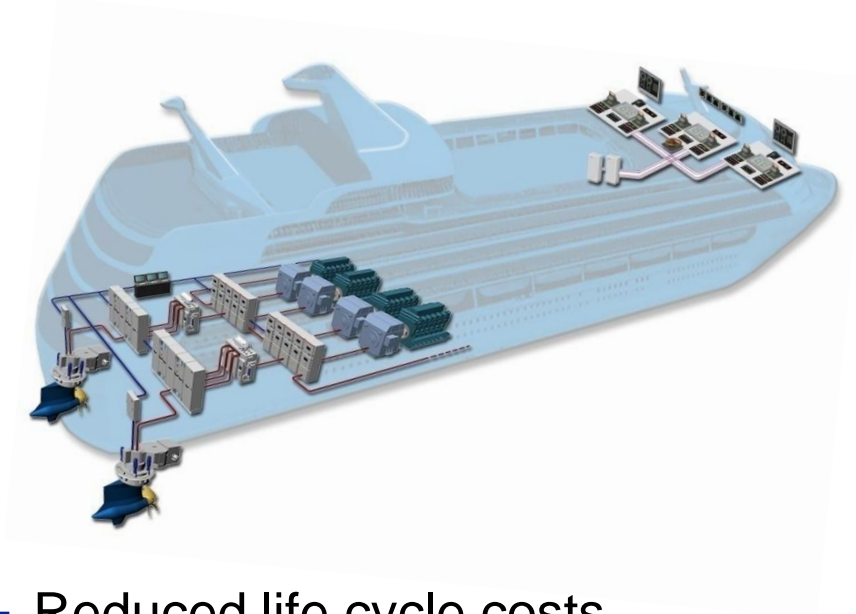

- Reduced life cycle costs
- Minimized emissions
- Enhanced maintainability
- Flexible integration to ship hull
- Improved reliability

Azipod[®] XO System Features

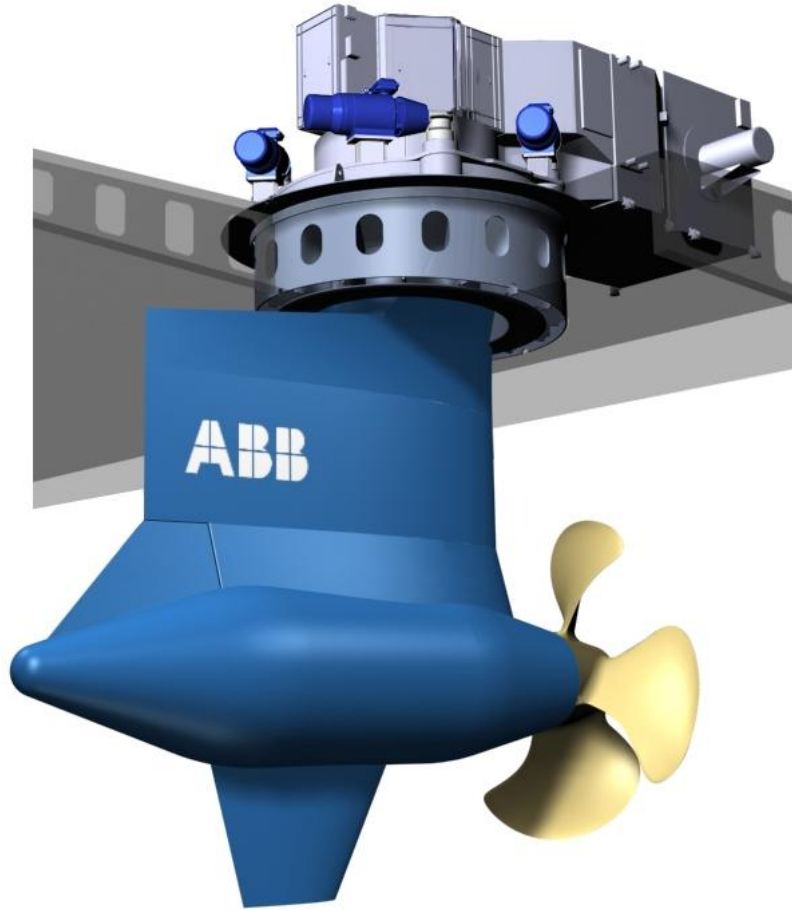

- Freely 360 degree rotating Azipod unit
- Fixed pitch pulling propeller
- Undisturbed water flow to propeller
- Extremely low vibrations

Efficiency development history (Azipod V and X)

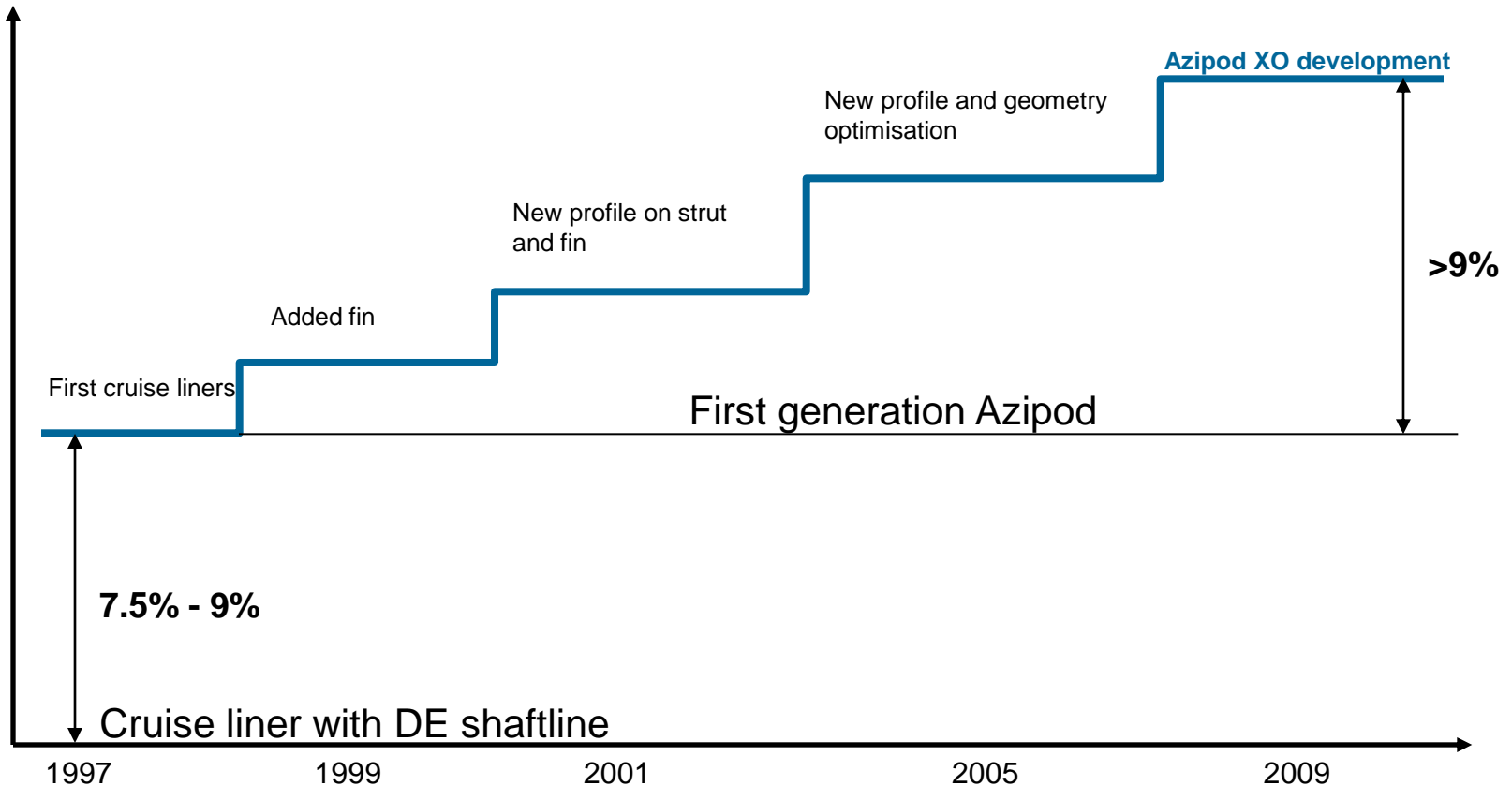

Designed for fuel saving up to 20%! *)

*) Compared to reference diesel – electric shaft line cruise liner

Azipod® XO

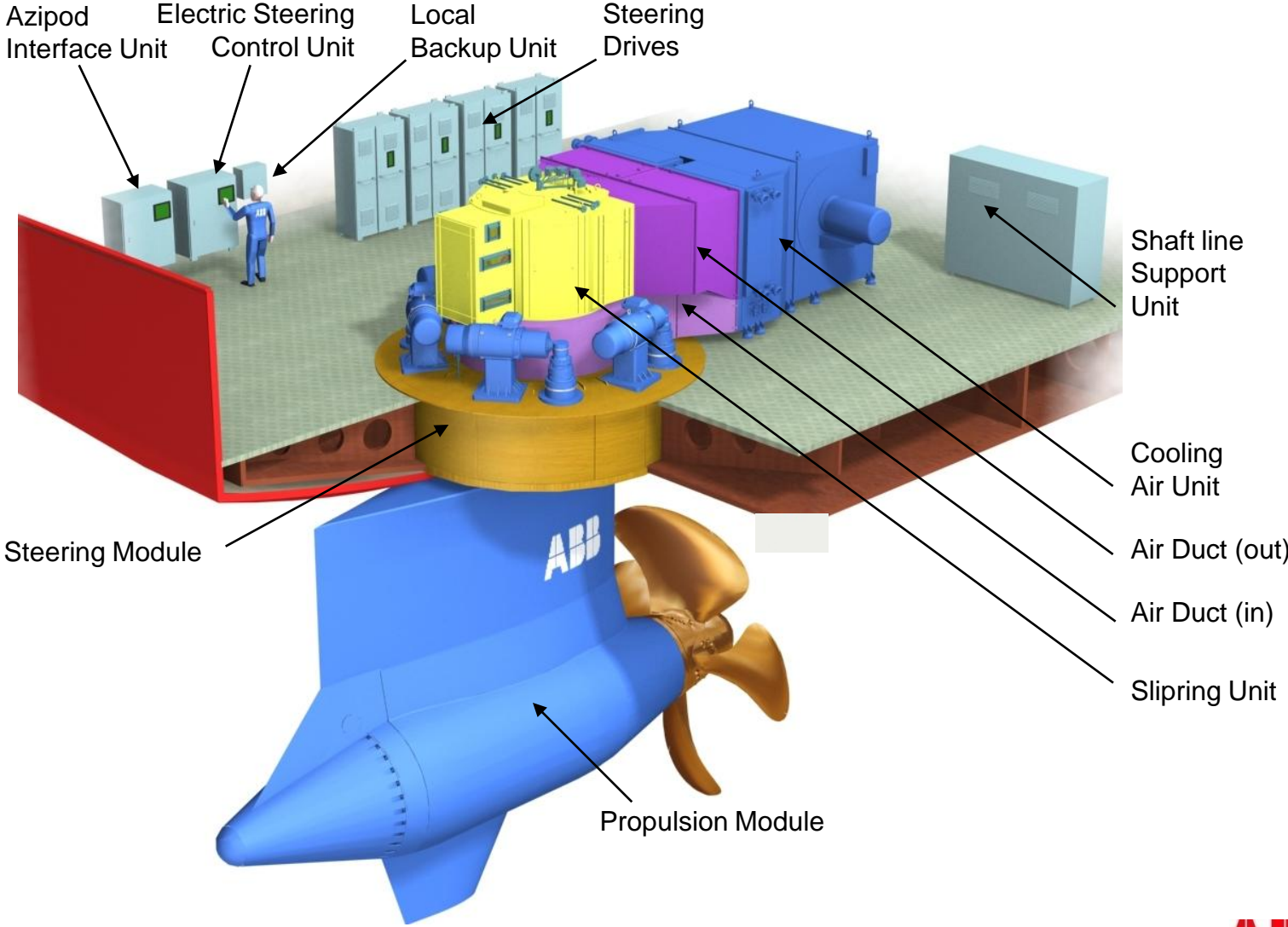

Main Components and new features

Advanced condition monitoring

Steering torque reduced over 20 %

Easy and safe access to Azipod unit

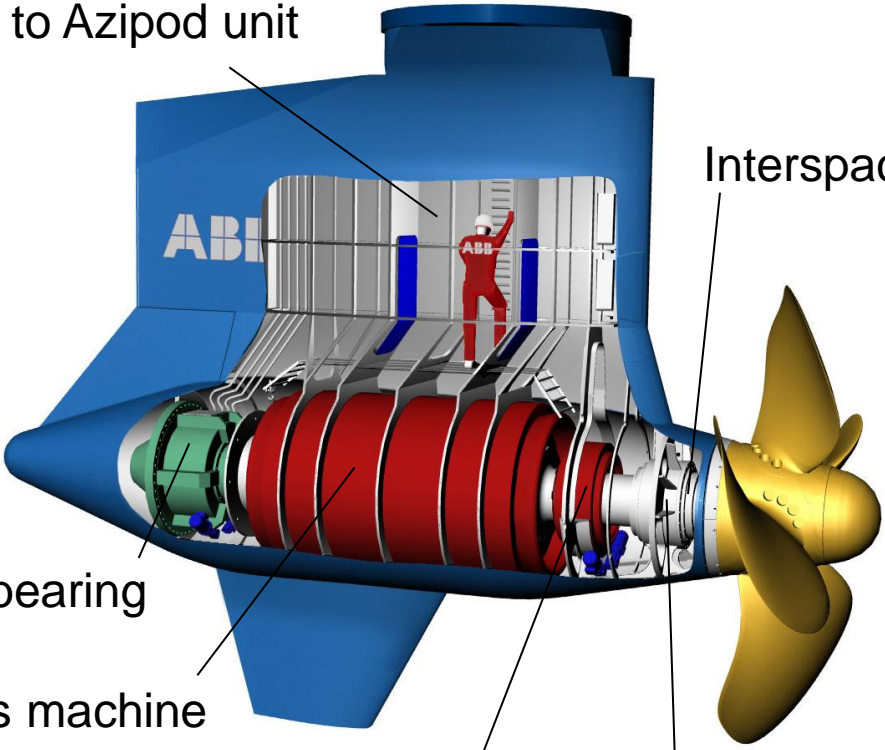

Interspace seal arrangement

Non drive end hybrid bearing

Synchronous machine

Excitation machine

Drive end bearing

Advanced Condition Monitoring

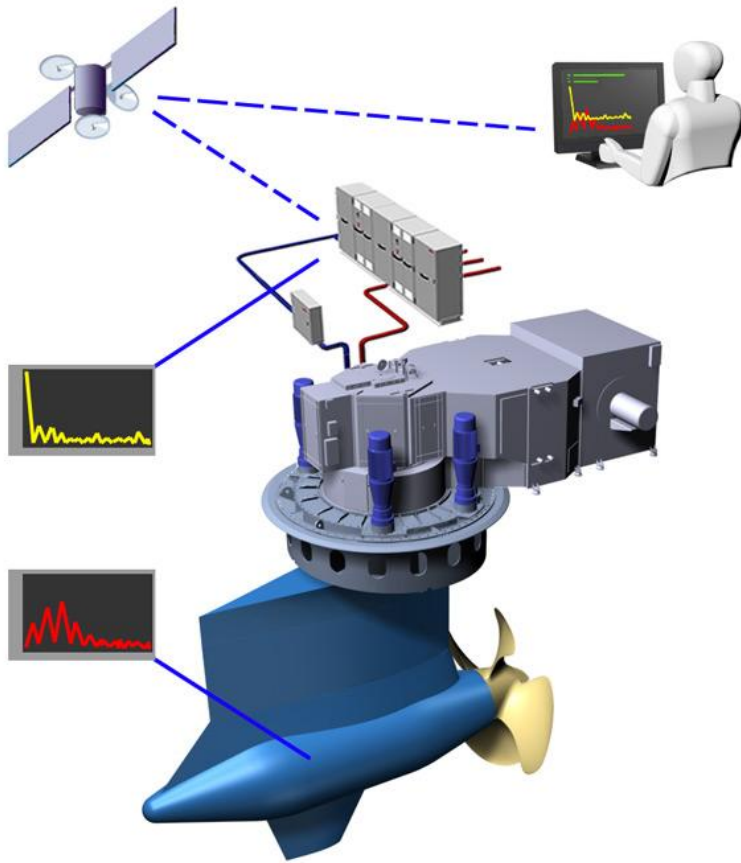

- Remote Diagnostics
 - Preventive maintenance
 - Troubleshooting
- Monitored Systems
 - Propulsion and steering systems
 - Bearings
 - Seals
 - Lubrication

Interspace - Revolutionary Shaft Seal Arrangement

Seal change possible inside the Azipod unit *)

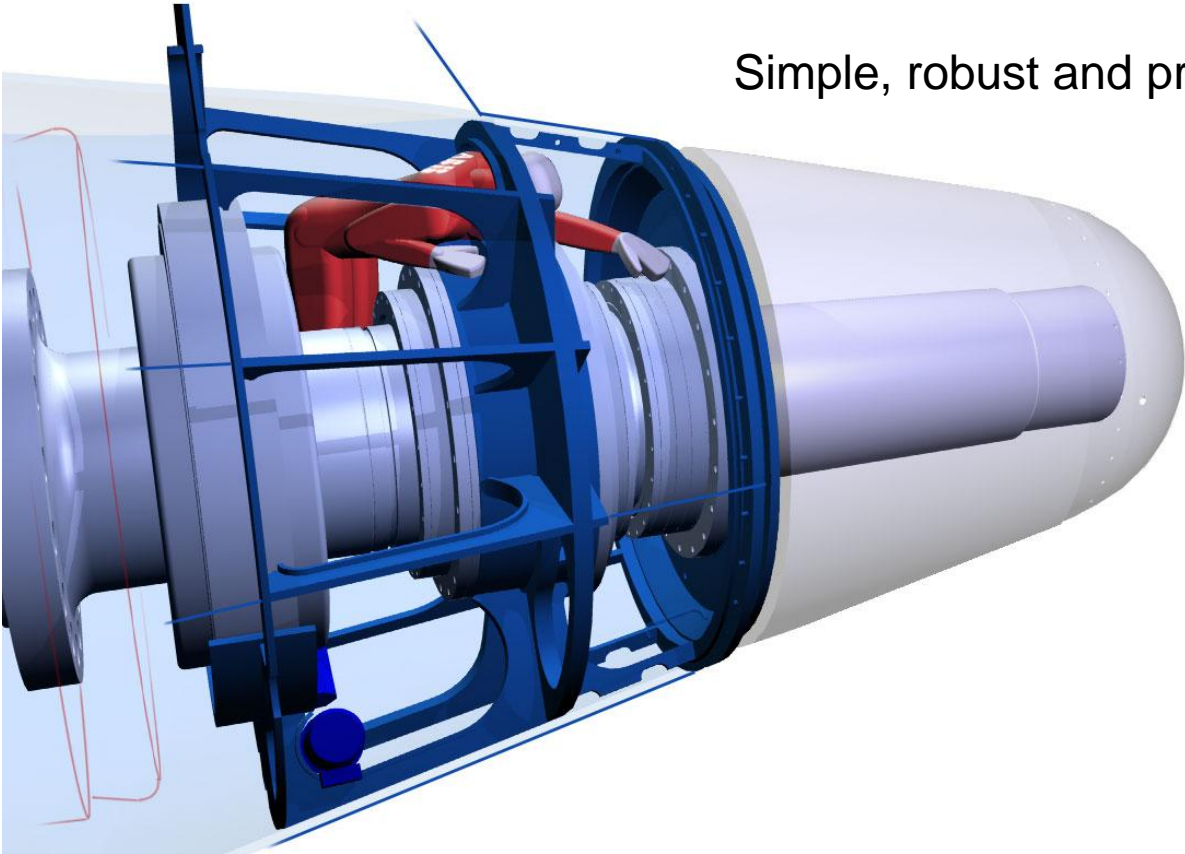

Simple, robust and proven technology

Patent pending

(*) depending on frame size



Interspace - Revolutionary Shaft Seal Arrangement

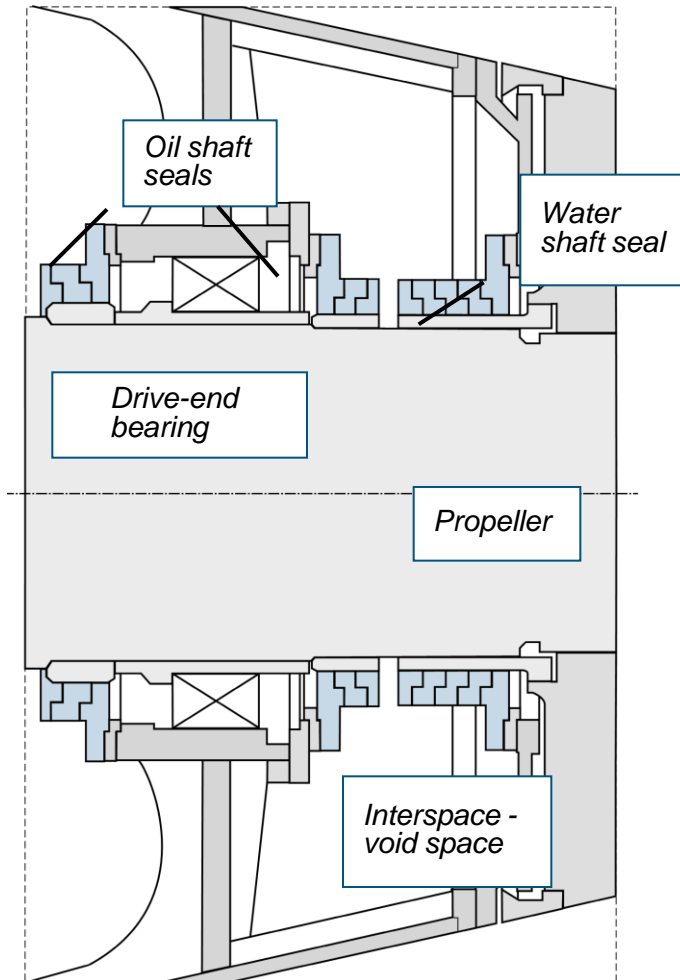

- Bearing oil seal separated from water seal
- Lubrications optimized for bearing and sealing – long lifetime
- Capacious void space with drainage for occasional leakages
- Designed for maximum reliability
- Designed to operate without harmful external leakages
- Protect the sea – **biodegradable** lubrication

Patent pending

No water to bearing oil – no bearing oil to the sea!

Hybrid Bearing, innovation which combines the advantages of two different types of bearings

Well known and proven technologies

Thrust pad change inside Azipod unit

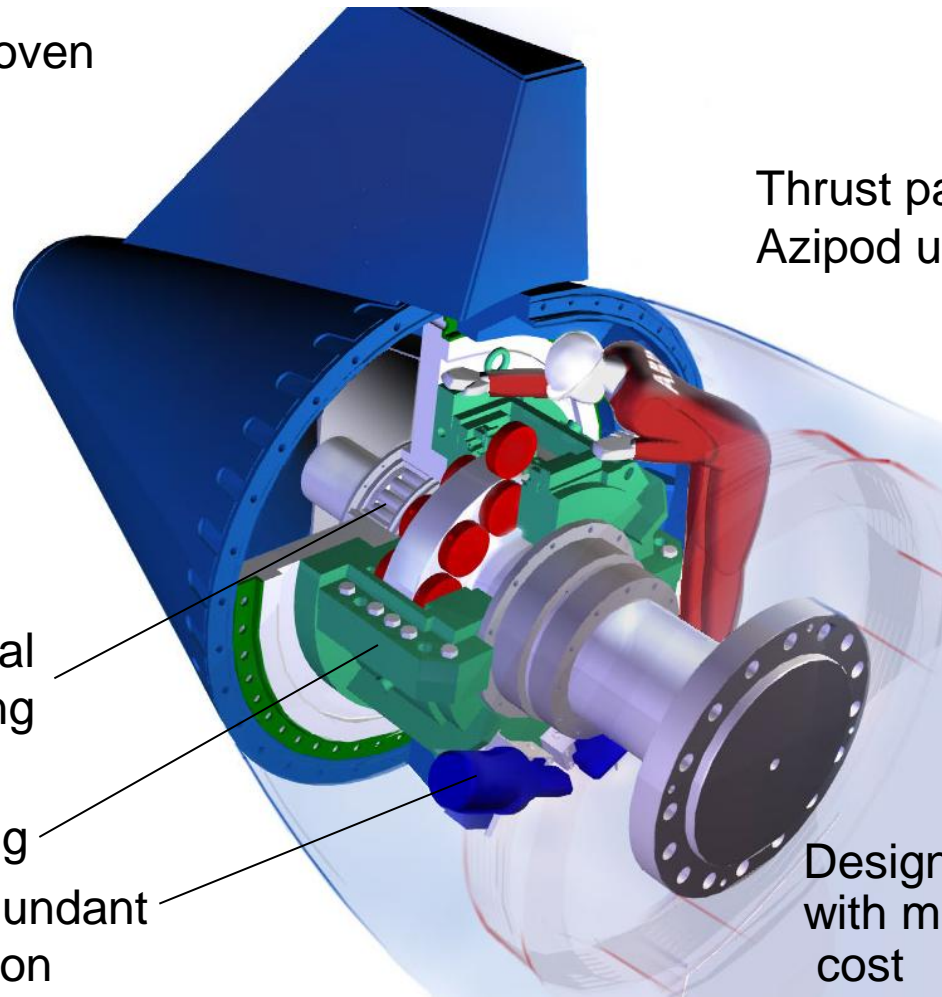

Non-drive-end radial **roller** bearing

Slide thrust bearing

Redundundant lubrication

Designed to be robust with minimum maintenance cost

Patent pending

Electric Steering

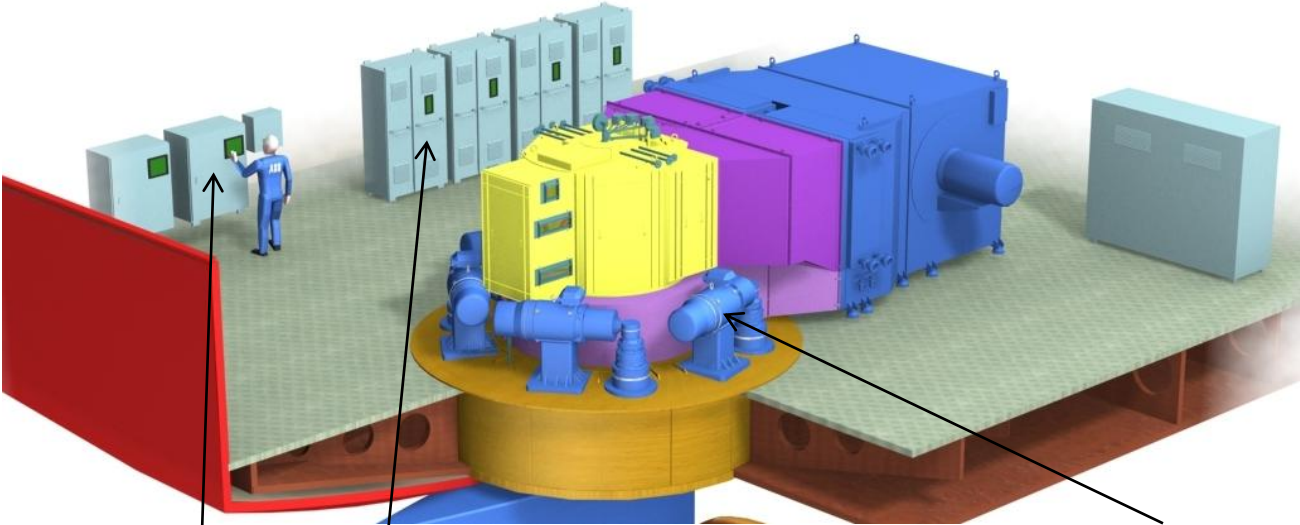

Electric steering control unit

Steering Drives

Steering motors

- Low noise
- Low vibration
- Easy Installation
- Proven Solution from Azipod[®] C
- Redundant steering drive system
- Environmentally friendly

Steering Module

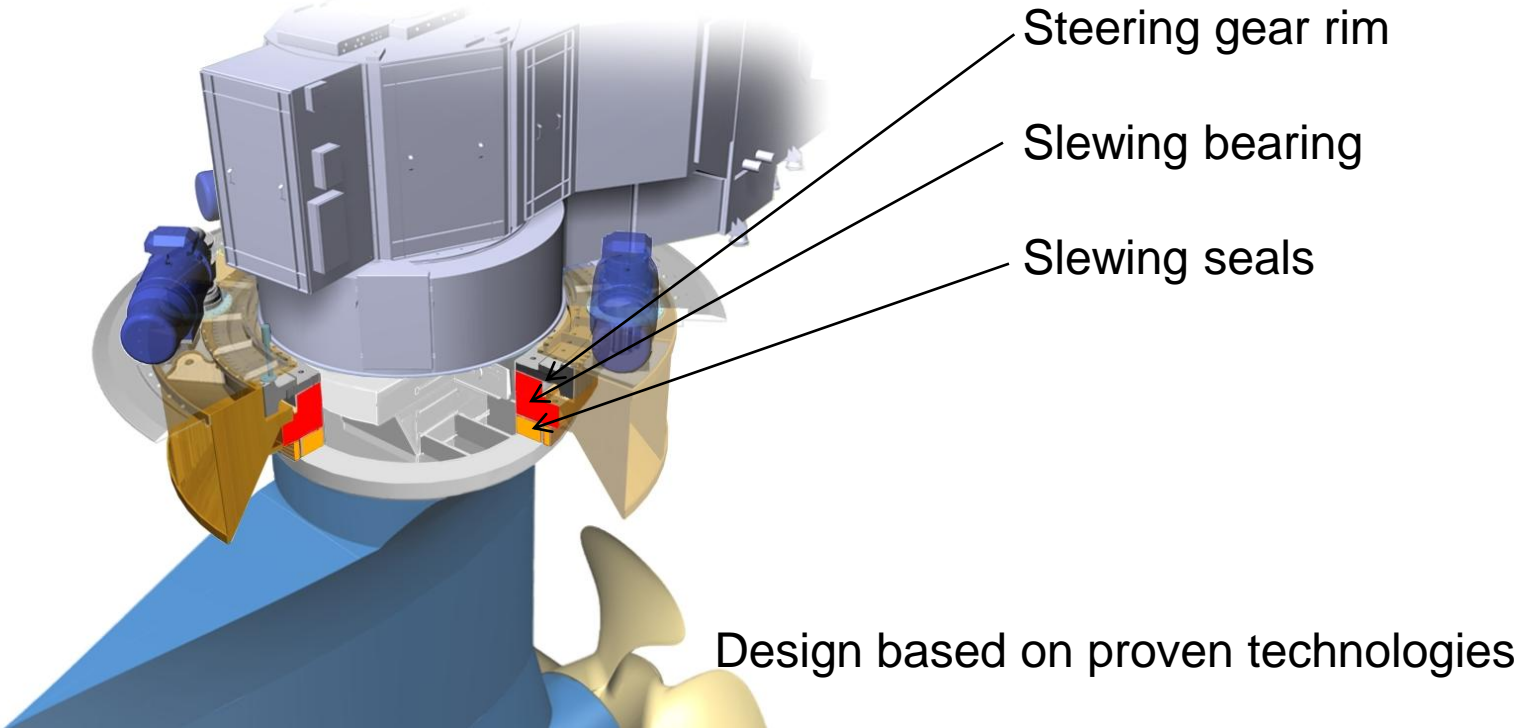

Design based on proven technologies

Designed for improved maintainability of slewing bearing and seals

Air-actuated seal for emergency cases

Intelligent Bridge Control Interface, Enhanced usability of Azipod[®] user interface on bridge

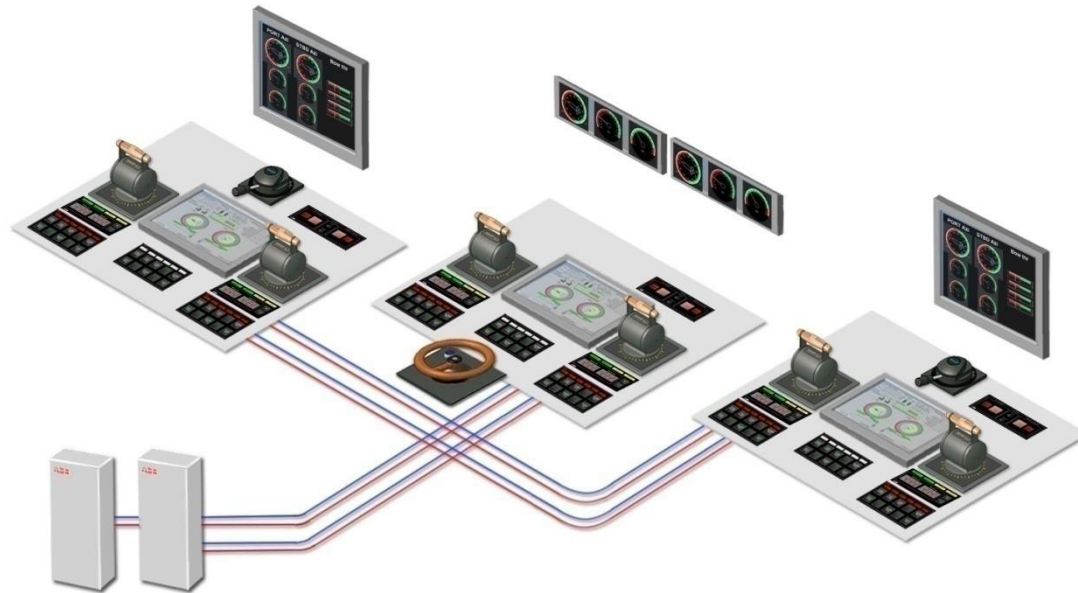

- Real time information for optimized operating practices
- Improved presentation of system state for deck officer
- Fieldbus-based modular system architecture

Intelligent Bridge Control Interface

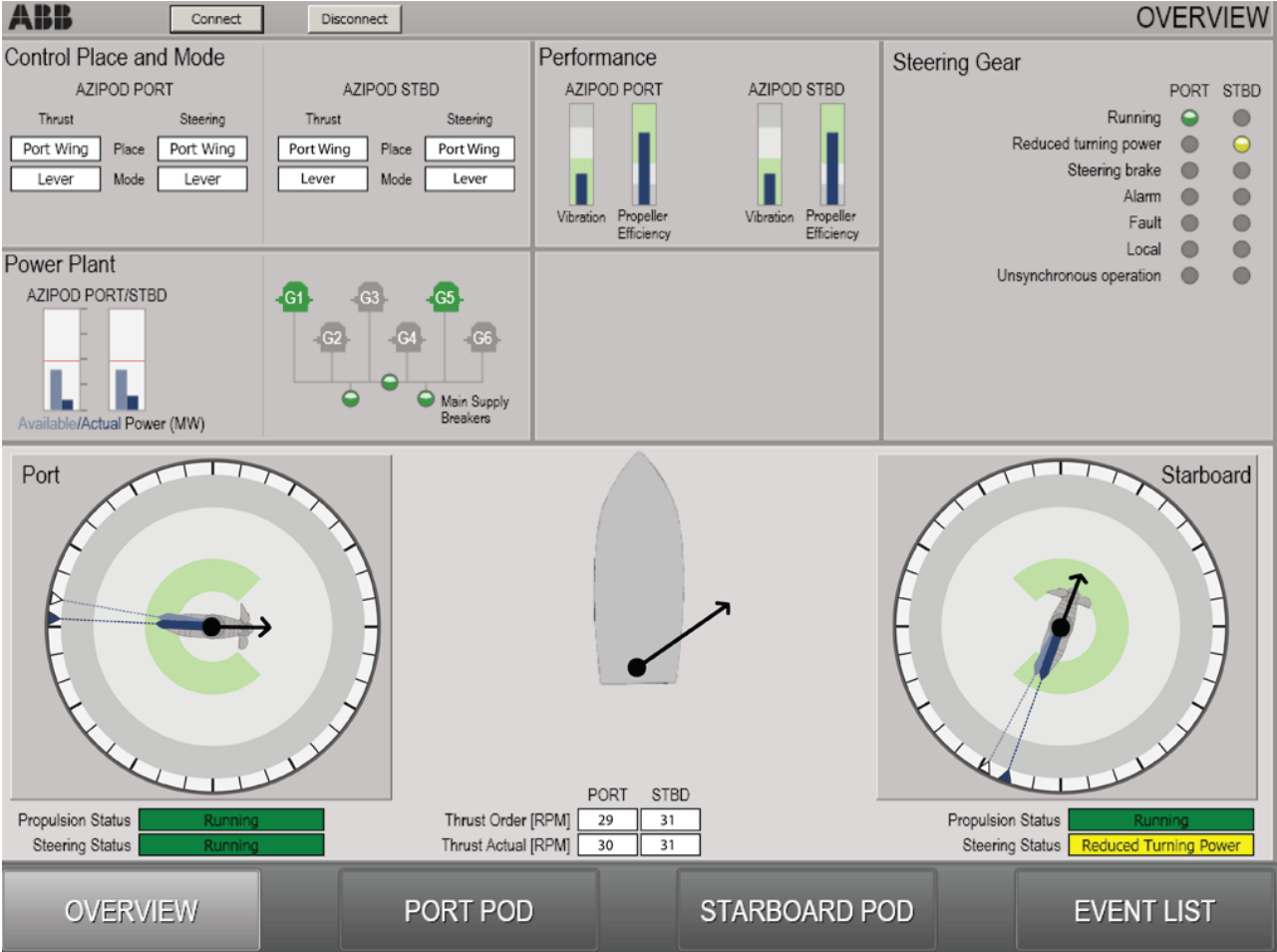

Azipod® XO Product Series

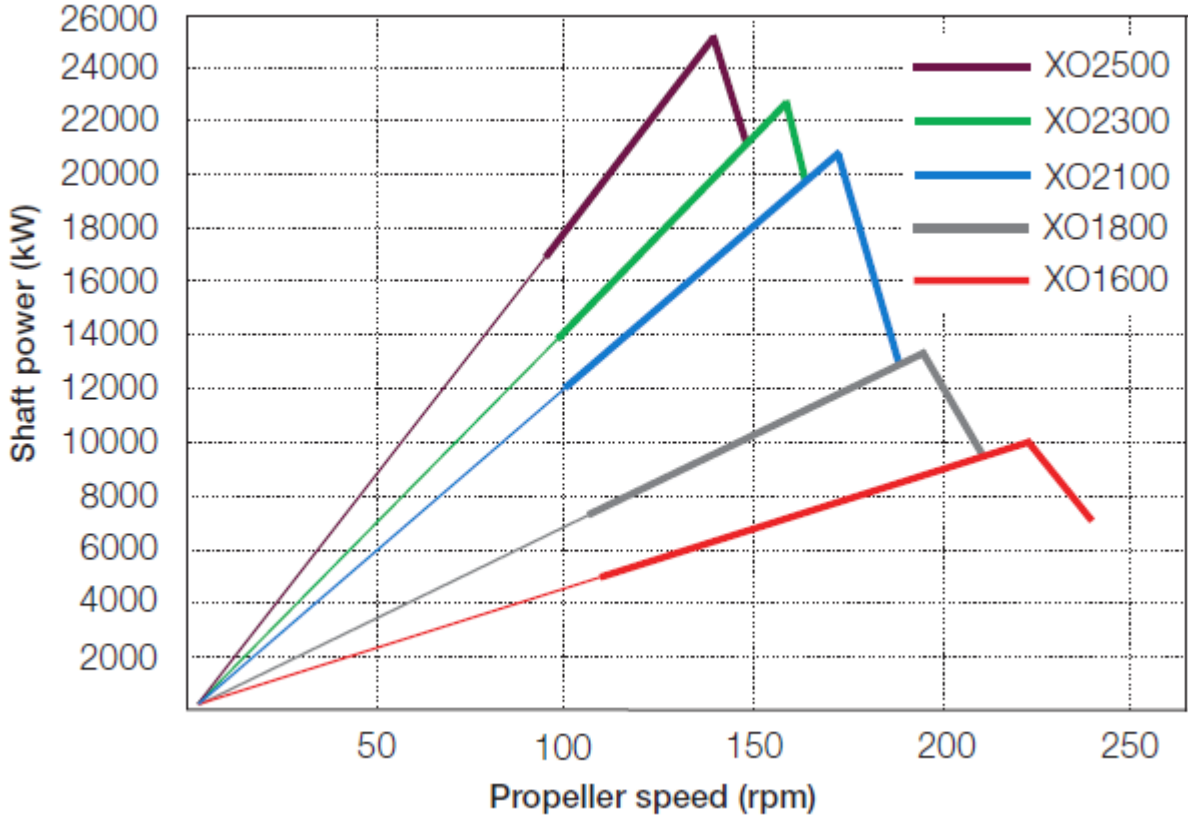

Azipod® X References

Owner	Ship type	Power/ship	
Celebrity Cruises	Cruise vessel	2 x 17,5 MW	
Japanese owner	2 pcs Fast ferries	1 x 11,8 MW	CRP concept
NCL	2 pcs Cruise vessels	2 x 17,5 MW	



NCL cruise vessel, picture by Meyer Werft

Summary for Azipod[®] XO



- Power up to 20+ MW per unit
- Energy efficient
- Designed for extended docking intervals of future needs
- Electric steering and intelligent control systems
- Optimised maintainability
- Advanced condition monitoring

...Steering to Success!

Power and productivity
for a better world™

