

Description**General**

RXTBA 1 is a three-phase phase sequence voltage filter built up by resistors and capacitors. The filter is available in two voltage variants; one for rated voltage 3x110 V 50 Hz and one for rated voltage 3x120 V 60 Hz.

Both variants can be used for measuring the positive sequence voltage U_p or the negative sequence voltage U_n .

The filter has two outputs adapted to supply the connected output relay with a voltage proportional to either the positive or the negative phase sequence component in the input voltage.

The output voltage in volt is equal to the phase sequence voltage in percent of the rated voltage when the output is loaded with the recommended output relay type RXEDK 2H, e. g. the relay voltage is 80 V when the positive phase sequence voltage is 80 % of the filter rated voltage and with the filter connected for positive sequence measuring.

Following operate values can be achieved together with the recommended output relays RXEDK 2H

Positive sequence voltage U_p : 25 – 150 % of the filter rated voltage

Negative sequence voltage U_n : 2,5 – 15 % of the filter rated voltage

The filter RXTBEA 2 is phased out during 2005.

The relay type RXEG 21 with scales 5-15 V and 40-120 V (used with RXTBEA 2) can also be used together with the RXTBA 1 filter to measure the negative and positive sequence voltages in the approximate ranges $U_n=9-27$ % and $U_p=38-115$ % of the filter rated voltage.

Application

The filter RXTBA 1 is used when it is required to measure or check the positive sequence voltage U_p or the negative sequence voltage U_n in a three-phase network.

RXTBA 1 for measuring the positive sequence voltage U_p , and undervoltage relay RXEDK 2H or RXEG 21, are used for indicating the voltage drop in the three-phase voltage, e. g. in load-shedding protection.

RXTBA 1 for measuring the negative sequence voltage U_n , and overvoltage relay RXEDK 2H or RXEG 21, are used for indicating incorrect phase sequence or phase failure.

If one phase to a motor is broken by a fuse, the back emf of the motor holds up the voltage in the open phase. Therefore an undervoltage relay may not surely be able to measure this abnormal condition, but a relay connected to a filter measuring the negative sequence component can do it. The per unit negative sequence component of the voltage resulting from an open conductor to a motor is equal to the ratio of the running to the starting currents of the motor. For example, a motor with a starting current of 6 per unit, the negative sequence voltage is approximately 16 % of rated voltage if the motor was running at full load when the fuse blew. The voltage is less if the motor was lightly loaded before the fuse blew.

Phase sequence voltage filter type RXTBA 1	SA2004-000800
Description	Rev. –
	Page 2(5)

Output relays

Measuring of the positive sequence voltage U_p :

The recommended relay is

RXEDK 2H, 1MRK 000 841-RA, set for scale constant $U_s = 1,0 \times U_r$ and connected for $U_r = 100 \text{ V } 50\text{-}60 \text{ Hz}$ according to Fig. 1, giving the scale ranges: $U_1 = 50\text{-}100 \text{ V}$ and $U_2 = 25\text{-}150 \text{ V}$.

The filter output is calibrated so the voltage to the connected recommended relay RXEDK 2H is 100 V when the filter is energized with a positive sequence voltage equal to 100 % of the filter rated voltage. Then the output voltage is directly proportional to the positive sequence voltage in to the filter. Thus the setting ranges in positive sequence voltage are $U_1=50\text{-}100 \%$ and $U_2=25\text{-}150 \%$ of the filter rated voltage.

The filter can also be used together with

RXEG 21, RK 411 101-DD or RK 411 102-DD, scale range 40-120 V. The setting range in positive sequence voltage is approximately 38-115 % of the filter rated voltage.

Measuring of the negative sequence voltage U_n :

The recommended relay is

RXEDK 2H, 1MRK 000 841-KA, set for scale constant $U_s = 0,2 \times U_r$ and connected for $U_r = 50 \text{ V } 50\text{-}60 \text{ Hz}$ according to Fig. 2, giving the scale ranges: $U_1 = 6\text{-}12 \text{ V}$ and $U_2 = 3\text{-}18 \text{ V}$.

The filter output is calibrated so the voltage to the connected recommended relay RXEDK 2H is 100 V when the filter is energized with a negative sequence voltage equal to 100 % of the filter rated voltage. Then the output voltage is directly proportional to the negative sequence voltage in to the filter. Thus the setting ranges in negative sequence voltage are $U_1=6\text{-}12 \%$ and $U_2=3\text{-}18 \%$ of the filter rated voltage.

The filter can also be used together with

RXEG 21, RK 411 101-DA or RK 411 102-DA, scale range 5-15 V. The setting range in negative sequence voltage is approximately 9-27 % of the filter rated voltage.

Check of the operate value

The operate value of the relay connected to the filter can be checked by using a single phase voltage source. Disconnect the ordinary 3-phase voltage source from the filter input terminals 11, 21 and 22. Then connect the terminals 11 and 22 together and connect an adjustable AC voltage to the terminals 11 and 21. This AC voltage is to be three times the voltage to neutral for 3-phase systems to produce the corresponding output voltage. A relay which is to operate at 10 % of the rated voltage $3 \times 110 \text{ V}$, should operate at approximately $3 \times 0,10 \times 110 / \sqrt{3} = 19 \text{ V}$ single phase.

Phase sequence voltage filter type RXTBA 1	SA2004-000800
Description	Rev. – Page 3(5)

Technical data

Rated voltage U_r	3x110 V 50 Hz and 120 V 60 Hz
Overload capacity continuously during 10 s	120 % of U_r 150 % of U_r
Output voltage to the recommended output relay	1 V per positive or negative sequence voltage in % of the rated voltage U_r
Setting ranges with RXEDK 2H, 1MRK 000 841-RA stage U1 stage U2	50-100 V, equal to $U_p=50-100$ % of U_r 25-150 V, equal to $U_p=25-150$ % of U_r
RXEDK 2H, 1MRK 000 841-KA stage U1 stage U2	5-10 V, equal to $U_n=5-10$ % of U_r 2,5-15 V, equal to $U_n=2,5-15$ % of U_r
RXEG 21, scale 40-120 V RXEG 21, scale 5-15 V	Equal to approximate $U_p=38-115$ % of U_r Equal to approximate $U_n=9-27$ % of U_r
Power consumption	0,4-0,6 VA per phase at $U=U_r$
Nominal operative temperature range	-25 °C to +55 °C
Dielectric test Impulse voltage test	2,0 kV, 50 Hz, 1 min 5,0 kV, 1,2/50 μ s, 0,5 J
Dimension	2U 6C
Weight	153 g

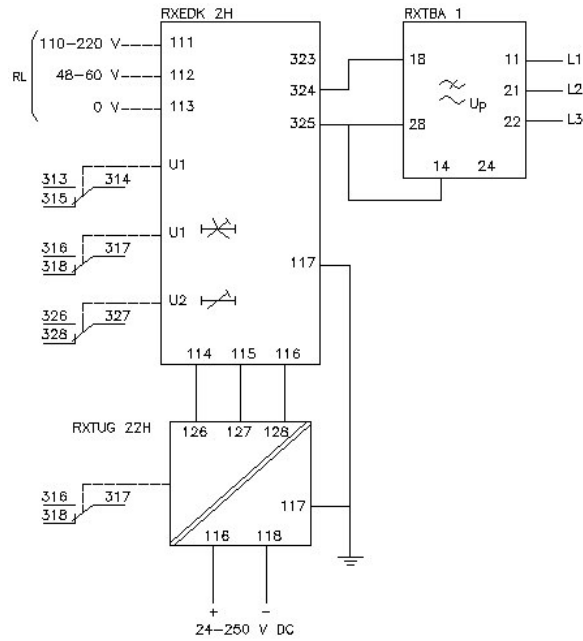

Fig. 1. Terminal diagram for measuring the positive sequence voltage U_p

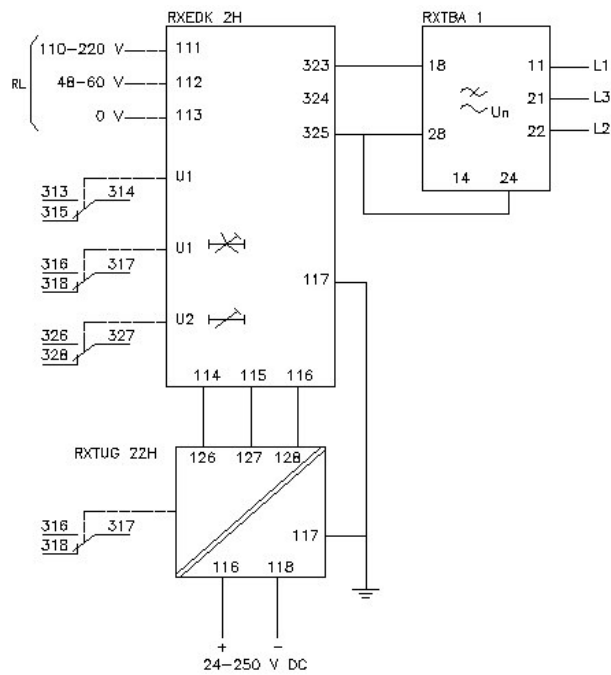

Fig. 2. Terminal diagram for measuring the negative sequence voltage U_n

Phase sequence voltage filter type RXTBA 1 Description	SA2004-000800 Rev. – Page 5(5)
--	--------------------------------------

Ordering

Specify

- Phase sequence filter RXTBA 1
- Voltage relay RXEDK 2H
- DC/DC converter RXTUG 2H
- Quantity
- Ordering No. according to below

RXTBA 1, Ur= 3x110 V 50 Hz	1MRK 002 261-AA
RXTBA 1, Ur= 3x120 V 60 Hz	1MRK 002 261-BA
RXEDK 2H, Ur=20/50 V 50-60 Hz (sharp)	1MRK 000 841-KA
RXEDK 2H, Ur=100/200 V 50-60 Hz (standard)	1MRK 000 841-RA
RXTUG 2H, 24-250 V DC / ±24 V DC	1MRK 000 592-A

References

Time over/under voltage relay RXEDK 2H	1MRK 509 004-BEN
DC-DC converter RXTUG 22H	1MRK 513 001-BEN
Connection and installation components	1MRK 513 003-BEN
Relay mounting systems	1MRK 514 001-BEN



ABB Power Technologies

Substation Automation Products
 Nätverksgatan 3, Västerås, Sweden
 Phone: +46 21 342000, Fax: +46 21 324223
www.abb.com/substationautomation