

Improved earth fault protection for high impedance earthed networks

1 Introduction

Sub-transmission networks in Sweden within the voltage range 40 – 70 kV have high impedance system earthing. The earth fault protection systems in these networks are based on zero sequence current and voltage measurement. The primary quantities have the following characteristics:

- In case of a phase to earth fault in the network, the zero sequence voltage is equal in all points in the network.
- The amplitude of the zero sequence fault current (the current in the fault point at a phase to earth fault) is independent of the fault location.

This means that neither impedance protection nor normal overcurrent protections can be used for detection and clearance of single phase to earth faults. The normal procedure is to use sensitive directional zero sequence overcurrent protection with constant time delay. To achieve selectivity different time delays are used for the different line protections. The protection most remote in the network has the shortest delay. The time delay increases successively for the protections closer to the source of the zero sequence current.

In some of the 70 kV networks the utility had a very complex structure with meshed network and multiple feeding points from the transmission grid. This resulted in some difficulties:

- The fault time for phase to earth faults hitting some lines gave unacceptable long fault duration.
- For some phase to earth faults it was impossible to achieve selective fault clearance

ABB Power Technologies got the task to study the problem area and to suggest actions in order to get acceptable earth fault clearance in the 70 kV networks.

The schematic design of the 70 kV systems can be described as in the figure:

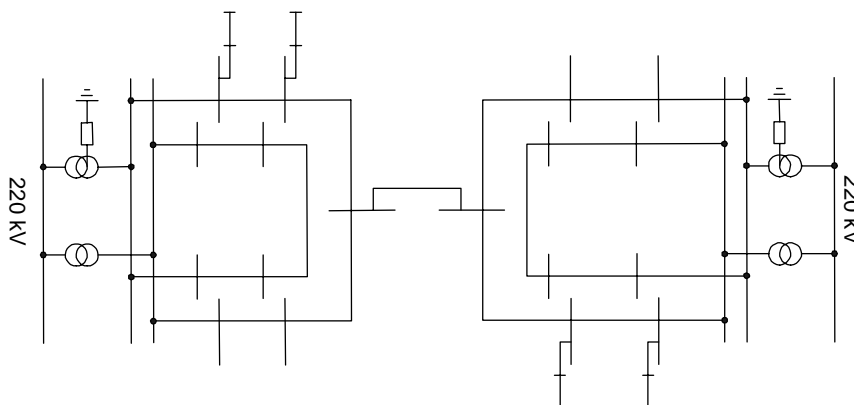

Figure 1. In the study the problems were described and analysed. The study resulted in a number of alternative suggestions. The suggestions were divided in actions taken in the primary system and actions taken in the protection system.

1.1 Secondary system alternatives

- Decrease of the time gap between the protections in series. This alternative gives requirements on the time accuracy of the protections. As a consequence many old protections should be necessary to change.
- Introduction of line earth fault protection with a communication scheme. The protection scheme is based on conventional directional earth fault current protection, detecting phase to earth faults in forward and reverse direction. The scheme is also using residual voltage measurement. With this scheme the fault clearance time for phase to earth faults on lines can be significantly reduced.
- Introduction of line differential protection, using the zero sequence current on the line. So far there are no protection schemes on the market using this principle.

1.2 Primary system alternatives

- Change of switching state in the system so that the lines are operated in a radial scheme. This alternative enables the possibility to keep acceptable fault clearance times with existing protections. The drawback is that all earth faults on the lines will cause disconnection of customers. In addition to this the losses will increase compared to the meshed network.
- Change of system earthing to effectively earthing, and maintaining the system voltage. This can be done by the connection of some 70 kV transformer neutrals directly to earth. The phase to earth fault protection can be realized by means of distance protections or other established methods for effectively earthed systems.
- Change of system earthing to effectively earthing, and increase the system voltage to 130 kV. This can be done by the connection of some of the new 130 kV transformer neutrals directly to earth. The phase to earth fault protection can be realized by means of distance protections or other established methods for effectively earthed systems. The increase of system voltage will increase transfer capacity and reduce the losses.

2 Recommendation

It was recommended to the customer to introduce the alternative with earth fault protection using a communication scheme.

For more information please contact: