

We reserve all rights in this document and in the information contained therein. Reproduction, use or distribution of this document without the written authority of ABB Automation Technologies AB is strictly forbidden.

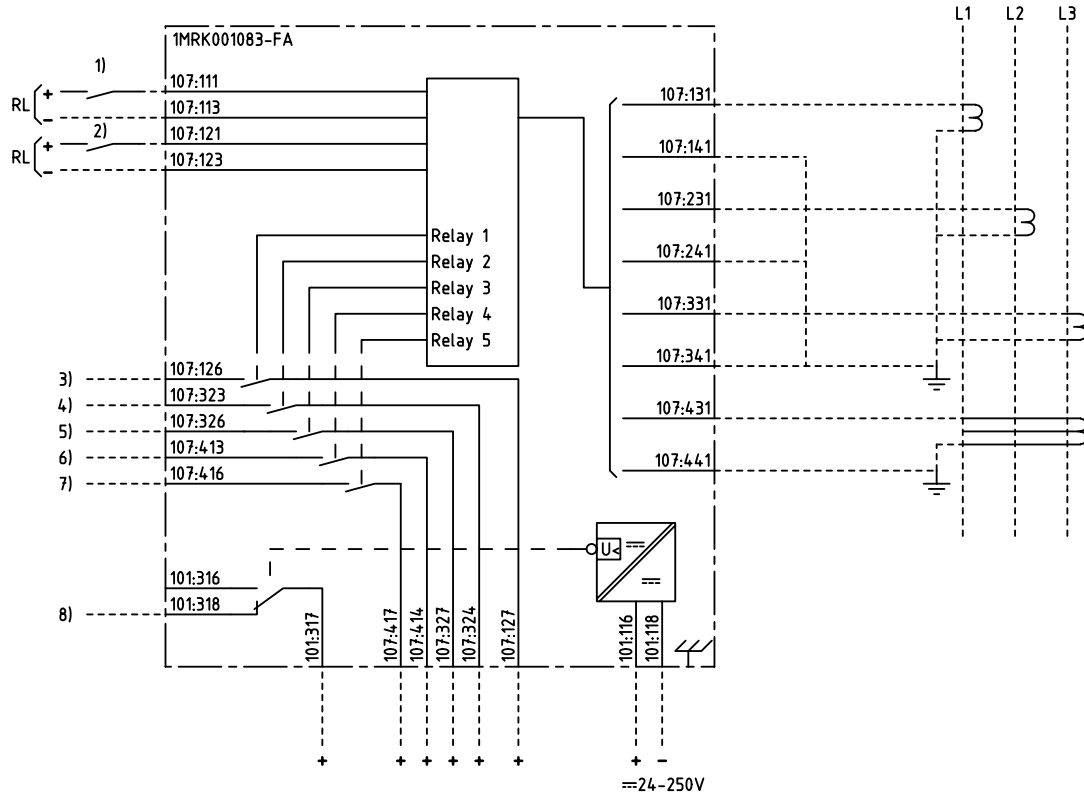

MULTI-FUNCTION CURRENT PROTECTION

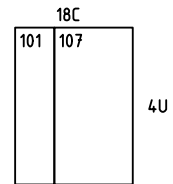

101 RXTUG 22H
107 RXHL 411

- 1), 2) BINARY INPUT, PROGRAMMABLE
- 3)-7) RELAY OUTPUTS 1-5, PROGRAMMABLE FUNCTION
- 8) LOSS OF AUXILIARY VOLTAGE

PROGRAMMABLE FUNCTIONS FOR BINARY INPUTS:
BLOCKING/ENABLING I>, I>>, I>>>, IN>, IN>>, IN>>>
THERMAL RESET 0, BREAKER FAILURE EXTERNAL START;
ALTERNATIVE SETTINGS; RESET OF LED INDICATIONS.

PROGRAMMABLE FUNCTIONS FOR BINARY OUTPUTS:
START AND TRIP I>, I>>, I>>>, IN>, IN>>, IN>>>;
THERMAL ALARM 0; THERMAL TRIP 0;
BREAKER FAILURE RE-TRIP; BREAKER FAILURE BACK-UP TRIP;
ALTERNATIVE SETTINGS; IN SERVICE

BINARY INPUT OPTIONS:
CIRCUIT-BREAKER CLOSED; CIRCUIT-BREAKER READY;
BLOCKING OF AUTORECLOSING; AUTORECLOSING EXTERNAL ON.

BINARY OUTPUT OPTIONS:
AUTORECLOSING ON; AUTORECLOSING READY;
AUTORECLOSING STARTED;
AUTORECLOSING PULSE TO CIRCUIT-BREAKER;
AUTORECLOSING UNSUCCESSFUL; INTENTIONAL OVERREACH TRIP.

Customer drw no	Prep. PTUA/ TPTD H Raza/JE 1999-09-27	Connection Diagram	Conf. sh/ No of sh
	Appr. PTUA/ Roger Karlsson 1999-09-27		
	Resp. dept PTUA/ TPTD	Document number	Lang. en
Based on	ABB ABB Automation Technologies	1MRK001083-FAA	Rev. 1
			Sheet 1

Document status: Approved