

Phasor based control of braking resistors – A case study applied to large power oscillations experienced in the Swedish grid 1997

1 Summary

Phasor measurement, i.e. AC voltages and currents represented as magnitude and phase angle from all over any power system, is now a reality. Based on GPS (Global Positioning System) time synchronization, phase angles at different geographical locations can be directly measured and compared. So far power oscillations in electric power grids have been detected only at their point of appearance, and damping control criteria have been based solely on local input quantities. PMUs (Phasor Measurement Units), located at strategic nodes in the power system, provide all necessary data for damping algorithms.

In the present paper a disturbance in Sweden, January 1, 1997, when two large nuclear units suddenly faced a large increase in transmission reactance, due to network split up, caused by clearance of a busbar fault, is studied. The generators started to oscillate with poor or negative damping, and after 6-8 seconds they tripped. The purpose of this Application Newsletter is to study the possibilities of the new phasor based technology applied to the disturbance from 1997.

Initially the pre-disturbance load flow is re-created in the simulation tool ARISTO [1], then the disturbance and fault clearance scenario is added, and finally different phasor based control algorithms for braking resistors, to counteract the oscillations, are tested, and compared.

The results show that the dynamic angle difference between the voltage vector of the "center" of the power system and an oscillating generator is a very suitable criteria for damping control. The disconnection of the two units (about 900 MW each) could probably be avoided with PMU-based on/off control of a 50 MW braking resistor. The braking resistor was in the study energized 6 times for a total time of 8 s.

2 Background

The aim of the present study is to investigate the benefit of power system voltage phase angle as input to a damping control algorithm. For this purpose a real, experienced disturbance is simulated and different control strategies are applied.

2.1 Synchronized Measurement Technology Development

The recent development in measurement technology and time synchronization accuracy has dramatically changed the possibilities for monitoring, control and protection of electric power systems. Development of PMUs and WAMS (Wide Area Measurement Systems) has been going on for some ten years now and quite reliable systems are in operation today. This technology is mostly applied in western US and Canada and in Mexico, but smaller systems are emerging all over the world today. So far phasor measurements have been used for monitoring and post fault analysis only. The PMU data were extremely useful, and speeded up the analysis and restoration process considerably, after the disturbances in western US in 1996 [2]. Nowadays discussions have started not to just store enormous amounts of data for post-fault activities, but also take the step to use these unique high quality phasor data for on-line control and protection. Therefore the ABB PMU – RES 521 – is based on protection technology and quality, i.e. all hardware and software components fulfill extremely high requirements on reliability and accuracy. This design makes RES 521 suitable not only for monitoring, but also for wide area control and protection.

2.2 Description of the Disturbance

The disturbance occurred late in the evening in the southwest of Sweden, when load was dropping and hydro power plants were about to be disconnected. The spinning reserve was large and the power system was well prepared to survive a major loss of generation. The Nordel network is shown in Figure 1. The totally installed

capacity in the system is about 90 GW. At the moment of the disturbance the power flow, around 1800 MW, was from south to north along the Swedish west coast.



Figure 1: The Nordel main grid, with the location for the disturbance marked.

In a major substation, close to Ringhals nuclear power station, water from a cooling equipment dripped to the ground and formed a growing icicle. The icicle finally caused a flashover to one phase and caused an earth-fault. The fault was located between the CT and the circuit-breaker, according to Figure 2, and was correctly cleared by the busbar protection, and later also by the transformer under-impedance protection.

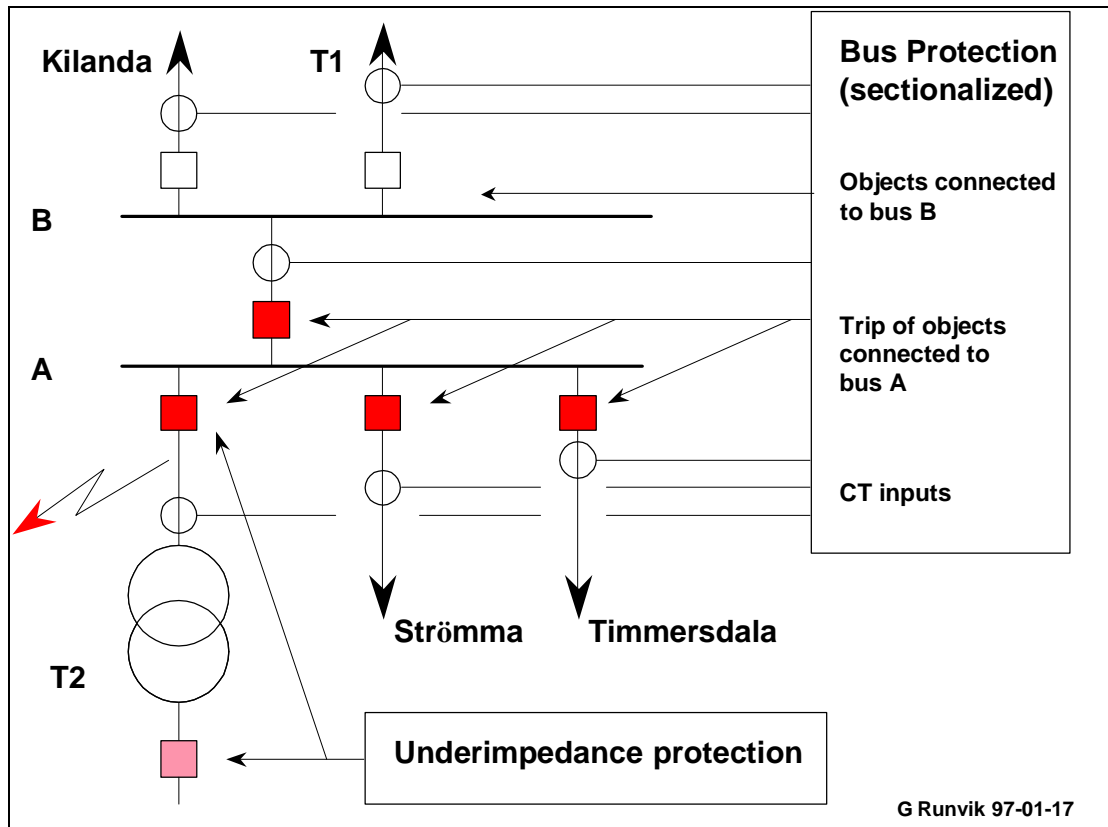

Figure 2: Busbar fault in Stenkullen substation 1997-01-01.

A number of 400 kV transmission lines were lost as a consequence of the clearance of the busbar fault. Reduction of transmission capacity on the main grid moved the power flow to the underlying 130 kV sub-transmission grid, and one line was tripped due to overload. The sudden change in 400 kV network topology, when the fault was cleared, caused two units in Ringhals to suddenly be very weakly connected to the rest of the system. Before the disturbance Ringhals 1&2 were connected to the main grid via substations Strömma and Stenkullen, see Figure 3. After the fault clearance the two units were connected to the main grid via substations Strömma, Breared, Söderåsen and Horred – a substantial increase in impedance!

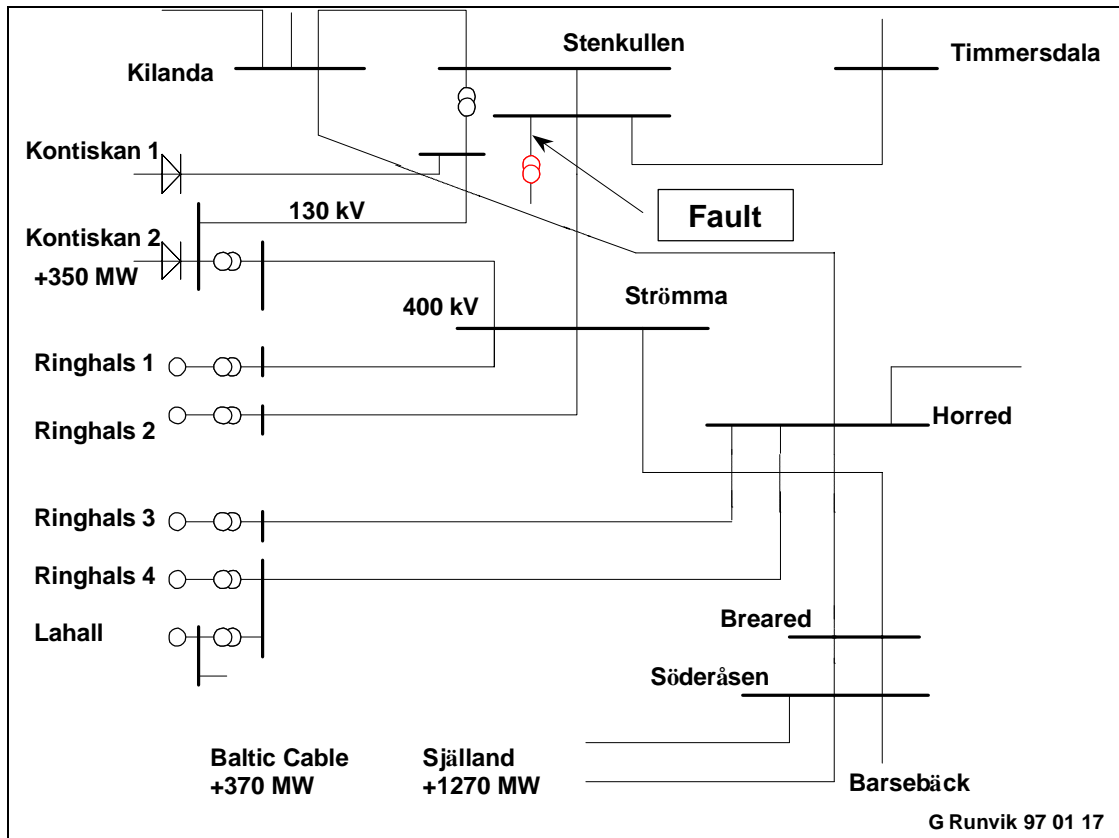

Figure 3: Topology change of transmission grid due to fault clearance.

The generation was about 900 MW per unit, and heavy oscillations were observed in the power system, sees Figure 4. The two units in Ringhals were tripped after 6.5 and 8.5 seconds, and the oscillations were damped. Losing 1800 MW is more severe than the dimensioning loss of production. Due to the late evening, load dropping and a large spinning reserve, no load shedding was activated. The frequency dropped to 49.4 Hz, which initiated automatic start up of gas turbines.

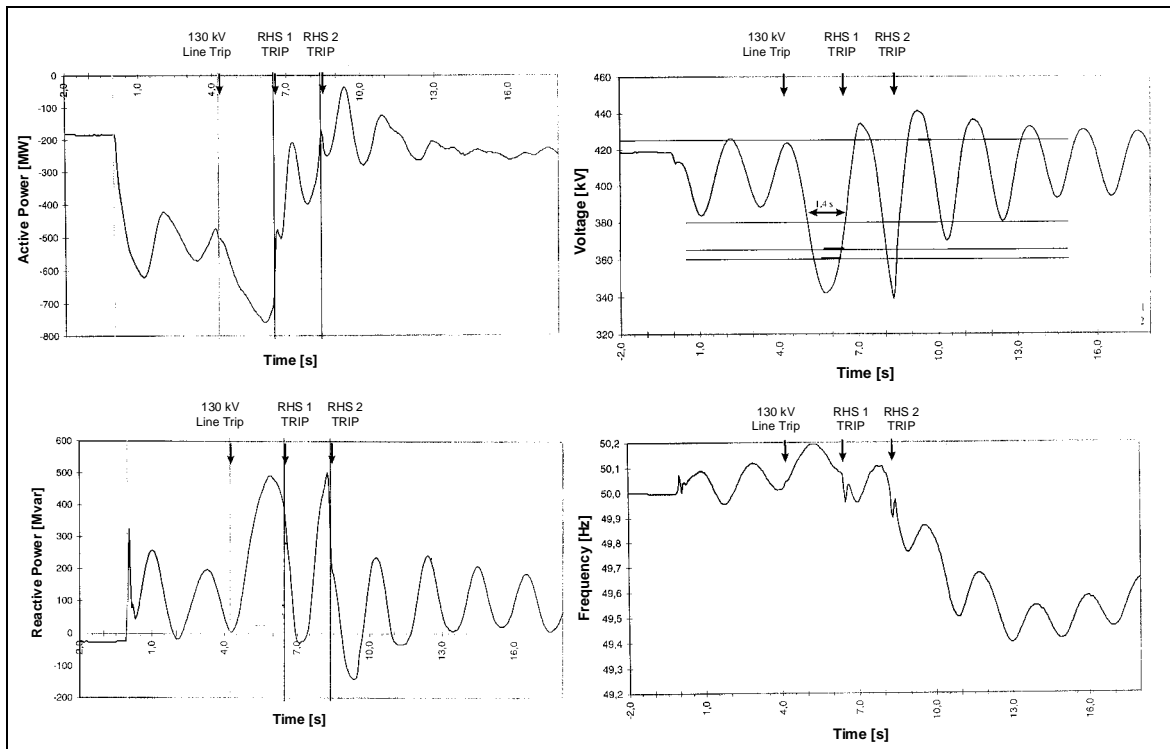

Figure 4: Oscillations in the power system due to topology change and generator trip (Sydkraft Recordings).

Upper left: 400 kV active power Barsebäck-Söderåsen.

Upper right: 400 kV voltage at Söderåsen substation.

Lower left: 400 kV reactive power Barsebäck-Söderåsen.

Lower right: 400 kV frequency at Söderåsen substation.

3 Power System Model Setup and Simulations

The power system model used for this study includes the entire synchronized Nordel network, according to Figure 1. The model is quite detailed in the neighborhood of the disturbance, i.e. southwestern part of Sweden, while equivalents are used for more peripheral parts of the grid. The real-time simulator ARISTO [1] was used for the study, which was carried out in three steps: 1) set up the pre-disturbance load flow; 2) apply the disturbance and the fault clearance scenario, and 3) add damping actions to ensure that the Ringhals units stay synchronized. The aim of the two first steps is to calibrate the model and the fault clearance scenario to recordings from the event. Most large generators are equipped with PSS (Power System Stabilizers), which act on the generator voltage control in such a way that the voltage set-point is altered a little with respect to power oscillations. Locally measured generator output power or frequency is usually used as input signal to the PSS. The PSS is very efficient to handle small signal oscillations, but since the PSS acts on the voltage controller, its capacity to handle larger oscillations is limited.

3.1 Comparison with Recordings

The simulation model was tuned by comparing ARISTO simulations of the disturbance scenario with recordings from the disturbance. Figure 5 shows the corresponding simulation results to the recordings in Figure 4.

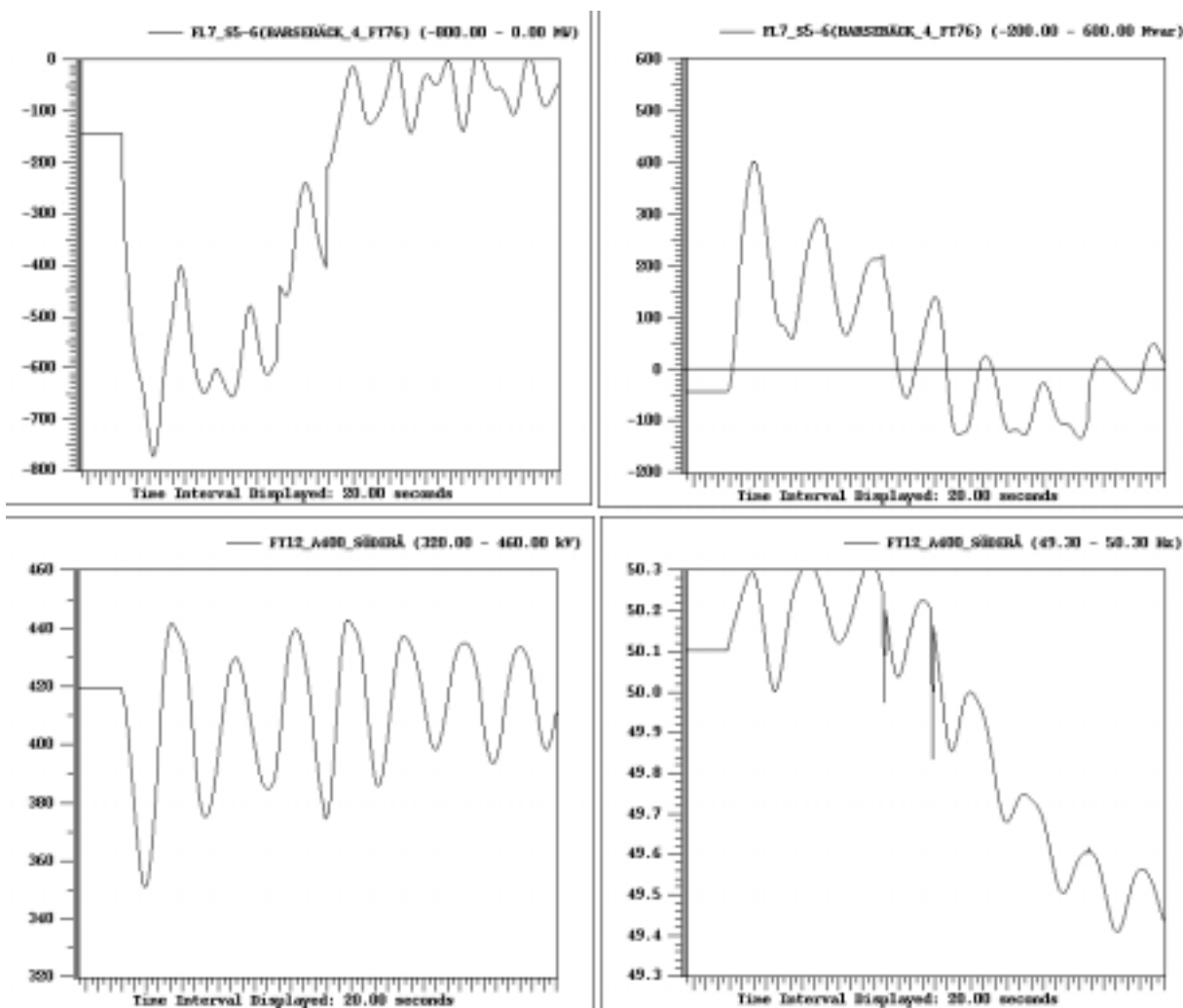

Figure 5: Simulation results corresponding to Figure 4.

- Upper left: 400 kV active power Barsebäck-Söderåsen.
- Upper right: 400 kV reactive power Barsebäck-Söderåsen.
- Lower left: 400 kV voltage at Söderåsen substation.
- Lower right: 400 kV frequency at Söderåsen substation.

3.2 Simulation of Scenarios without Generator Tripping

When the simulation model matched the recordings, actions aimed at keeping the two generators synchronized to the system could be studied. The well known KM-model for electromechanical oscillations was used to find the eigenfrequencies of the system [3]. It is also possible to use the eigenvectors in real-time, to find out how active each mode is. In a real power system the frequency, at each generator node participating in the oscillation, is compared to the system "average" frequency. The average frequency can be derived as the arithmetic mean value in a number of strategic nodes, weighted with respect to the inertia, "controlling" that frequency. Figure 6 shows the oscillations for the two units, if they were not tripped, and no damping actions were imposed. Each unit comprises two generators. In Figure 6, only the active power from one generator of each block is shown.

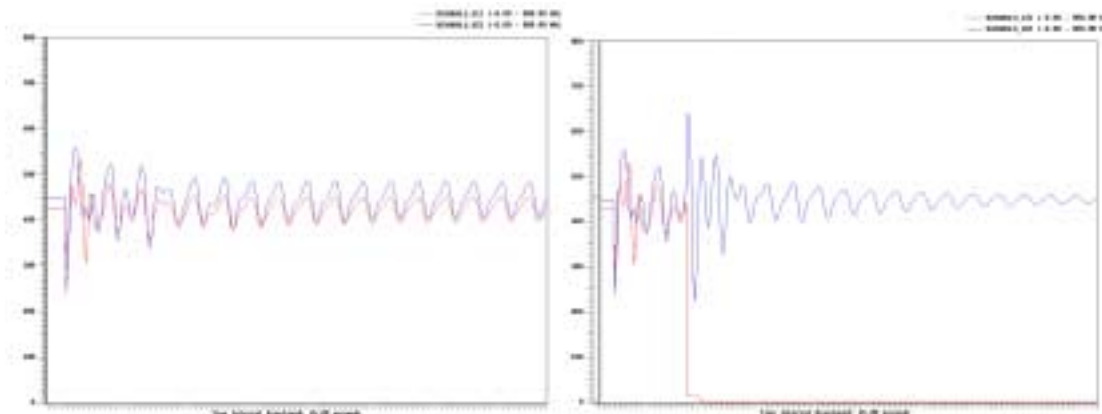

Figure 6: Simulation results for active power output, without tripping and without damping.
 Left: Both units kept synchronized.
 Right: One unit tripped.

4 PMU controlled Braking Resistors

The main idea of this study is to find methods to damp the power oscillation and prevent the unit protection from disconnecting the generators from the grid.

A simple controller according to Figure 7 and a 50 MW braking resistor for each generator seem to be sufficient. The input signal to the controller is the difference between the local frequency and the weighted average frequency of the power system. The output signal comprises square-waves of different duration, which connect the braking resistor, see Figure 8.

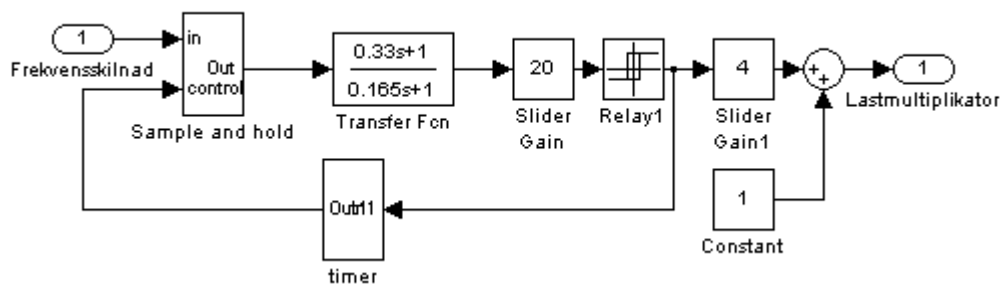

Figure 7: Controller, based on frequency difference input, for the 50 MW braking resistor.

To damp the power oscillations the braking resistor has to be switched in eight times for a total duration of about 8 seconds. For the two generators the braking energy corresponds to about 800 MWs. To be able to damp also the remaining minor oscillations, remaining after about 20-25 seconds, when the damping resistor is not used any more, smaller damping resistors have to be added, or, if small enough, the oscillations can be taken care of by the PSS on the AVR.

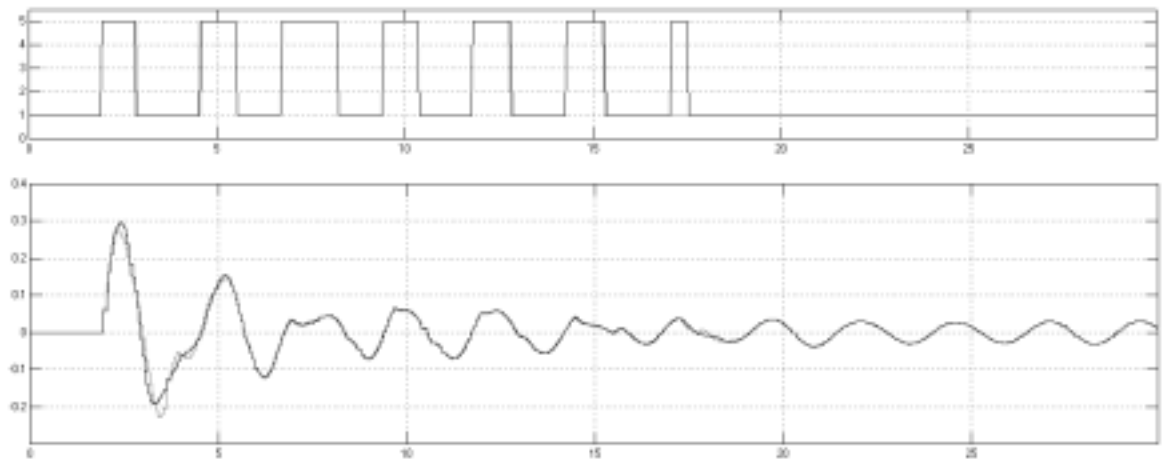

Figure 8: Controller output and input signals.

Finally the simulation result for the generator active power output is shown in Figure 9, for the case when the controller and the braking resistor are activated.

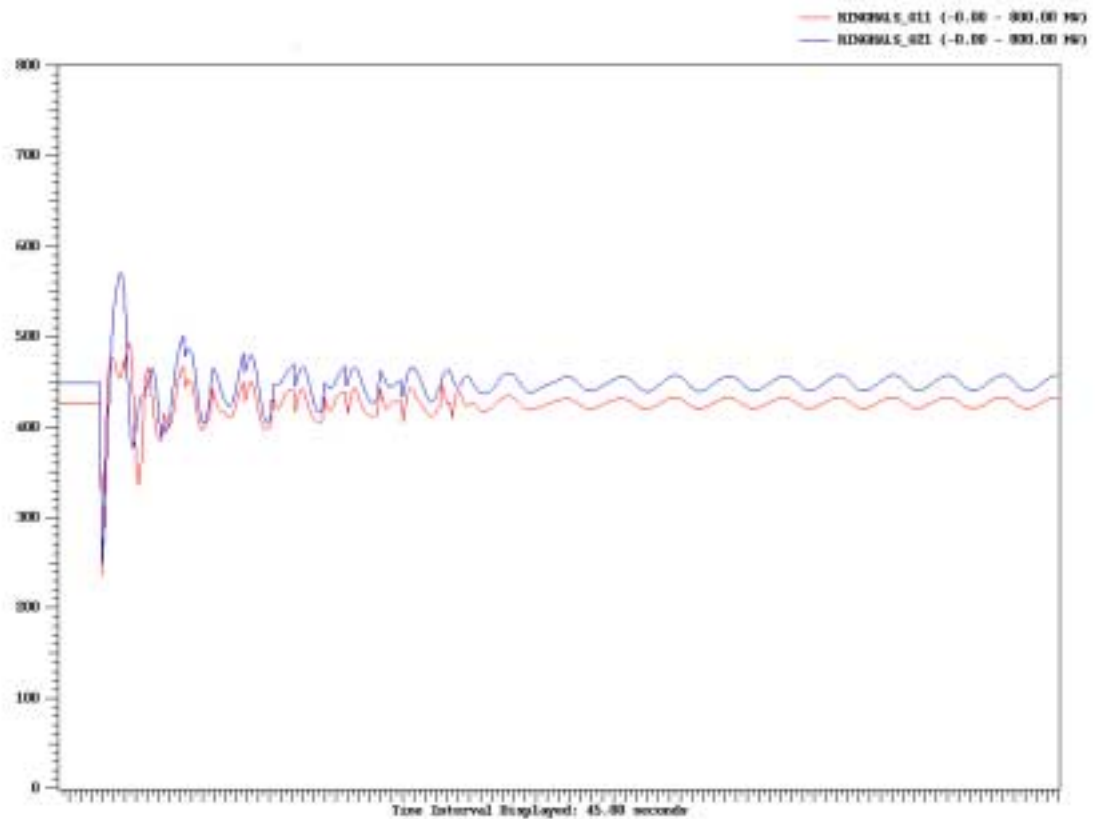

Figure 9: Generator active power output for the two units.

5 Conclusions

This study shows that with a very simple controller and a modest braking resistor, even rather heavily undamped oscillations can be controlled and damped. In this case the control signal was based on the frequency at the "center" of the power system, or a weighted average, and the local frequency.

6 References

- [1] **The training simulator ARISTO-design and experiences**; Walve, K.; Edstrom, A.; Power Engineering Society 1999 Winter Meeting, IEEE, Volume: 1, 31 Jan.-4 Feb. 1999.
- [2] **Recording and analyzing the July 2 cascading outage [Western USA power system]**; Taylor, C.W.; Erickson, D.C.; Computer Applications in Power, IEEE, Volume: 10 Issue: 1, Jan. 1997 Page(s): 26 –30.
- [3] **Damping of electro-mechanical oscillations in a multimachine system by direct load control**; Samuelsson, O.; Eliasson, B.; Power Systems, IEEE Transactions on, Volume: 12 Issue: 4, Nov. 1997 Page(s): 1604 –1609.

For more information please contact:

ABB Power Technologies AB
Substation Automation Products
721 59 Västerås, Sweden
Phone: +46 21 342000, Fax: +46 21 324223
www.abb.com/substationautomation