

## Benefits

- Conversion of one simple, non-redundant PROFIBUS line into two reciprocally redundant lines A/B
- Use on PROFIBUS DP/FMS lines
- Automatic line selection
- Transmission rate  
9.6 kBit/s .... 12 MBit/s
- Monitoring of communication
- Repeater functionality
- Redundant power supply
- Status and error display
- Monitoring of the power supply
- Potential-free alarm contact
- Simple assembly on  
DIN mounting rail
- CE,UL/CSA and  
Germanischer Lloyd certified

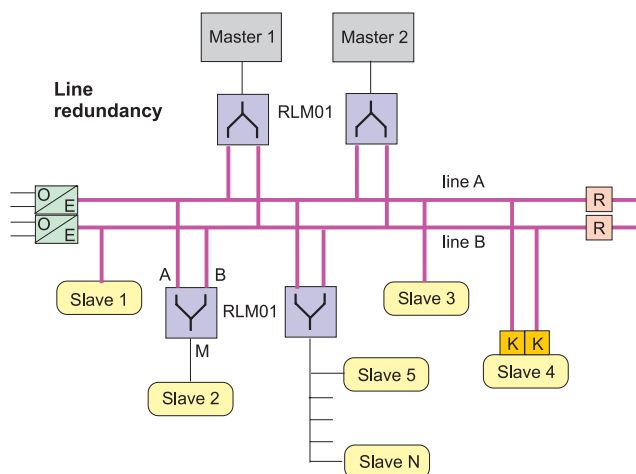

## Features



You can position the module directly after a master, before a bus segment with several slaves or before an individual slave. PROFIBUS stations with redundant couplers [K] can be directly connected to the PROFIBUS set redundant by RLM01. Stations with only one interface can be optionally assigned to the A or B line. Each RLM01 PROFIBUS interface can serve up to 31 PROFIBUS stations. Using repeaters [R] and media converters [O/E] makes it possible to increase the length of the PROFIBUS lines and the number of stations.

## Function

The three RS 485 interfaces of the module support all transmission rates specified in DIN 19245 for the PROFIBUS from 9.6 kBit/s to 12 MBit/s. The module has repeater functionality, i.e., it regenerates the signal shape and the amplitude of received data. RLM01 monitors all three lines A, B and M for activity and error states. Detected errors are signalled by lit diodes on the front panel. The potential-free alarm contact activated in parallel to this can be polled for diagnostic purposes by the process control system PCS or by a programmable logic control PLC.

The first data coming in over line A or line B with a correct telegram start are routed to terminal M. With simultaneity, either line A or line B is selected at random. Testing and selection is always based on the first character. In the case of a telegram start with error on A, the control logic switches to the redundant line B. The same procedure applies vice-versa for line B.

Data coming in over line M with a correct telegram start are routed in parallel to the two terminals A and B. The test for data is always based on the first character. In the case of a telegram start with error, the control logic does not output any data to A and B.

Either a single or a redundant power supply with 24 VDC is possible. The distribution of load across L1+ and L2+ is based on the level of the voltages applied. If a voltage source fails, the switch to the redundant supply source is made without interruption. A monitoring logic circuit tests whether both voltages are present.

RLM01 is certified for applications on ships and maritime systems by the Germanic Lloyd (GL). To keep the increased requirements regarding EMV and overvoltages RLM01 needs - depend upon supply (single / redundant) - one or two "24 VDC power pack filter (Surge)".

**Note:** Further information see User Instructions RLM01, document number: 3BDD011600R.

## Construction

Three Sub-D connectors A, B and M are located on the front panel of the RLM01 for connection of the PROFIBUS cable. The 8-pin male multi-pin connector with the associated terminal strip is used to connect the alarm and power supply wires. There are also LEDs for activity/error display, a rotary switch for setting the transmission rate and a reset button (activate transmission rate).

## Connectors / Terminals

Description:	Meaning:	Connection:
A	redundant PROFIBUS lines	9-pin Sub-D connector Open
B		
M		
Terminal strip	Power supply (L1+, L2+, M), alarm (F1, F2) and earth connection (E)	8 pole terminal strip

## Adjustment and indication

Description:	Meaning:	Remarks:
Act	Bus activity on line A, B or C	yellow LED
Err	Error on line A or B	red LED
Pwr	Power supply o.k.	green LED
Baud rate	Rotary switch for baud rate setting	9,6 kbd ... 12 Mbd
Reset	Button for transmission rate activation	-/-

## Technical data

Baud rate settings										
Switch setting:	0	1	2	3	4	5	6	7	8	9
Baud rate:	12	6	3	1,5	500	187,5	93,75	19,2	9,6	No function
Unit:	Mbd or MBit/s				kbd or kBit/s					

Technical data:	
Serial interfaces - Connections - Transmission rate - Type - Connection - Electrical isolation - Test voltage - Device protection class	A, B and M 9.6 kBit/s to 12 MBit/s RS 485 9-pin Sub-D connector To VDE 0110, functionally isolating 500 Veff 3
Data telegram delay - A/B==> M - M==> A/B	11 Bit times [us] + 0,6 us 4 Bit times [us] + 0,6 us
Power supply - Operating voltage - Power consumption - Power loss - Connection - Wire cross section	24 VDC (+20 .. +33 V) 150 mA typically at 24 V Approx. 3.6 W 8-pin terminal strip 0.14 ... 1.5 mm <sup>2</sup>
Ambient conditions - Operating temperature - Transport / storage temperature - Relative humidity	0 ... 50°C -30 ... 85°C Max. 75% non-condensing in operation
Alarm contact - Function - Switching voltage - Switching current	Open in case of error < 60 VDC Max. 1A

<b>Technical data</b> (continuation):	
Design - Dimensions - Weight - Protection - Attachment	134 x 56 x 70 mm (H,W,D) 330 g IP 20 DIN mounting rail, 35 mm
Certification - USA - Canada - Europe - ships and maritime systems	UL CSA CE Germanischer Lloyd (Category A, B, C, D), in connection with 24 VDC power filter (Surge)
Accessories (to be ordered separately, see Orderlist)	- 3 PROFIBUS connectors - 1 or 2 24 VDC power filter (Surge), depends on supply (single / redundant)

## Ordering Information

Pricebook: <b>Fieldbus Products, 3BDD012340</b> / Price List: <b>PROFIBUS, 3BDD012342</b>		
Description	Article No.	Delivery time
<b>RLM01</b> , PROFIBUS Redundancy Link Module for cable redundancy	<b>3BDZ000398R1</b>	
<b>Power supply filter</b> (Surge) 24 V DC Mandatory to fulfill the requirements of Germanischer Lloyd (GL)	<b>3BDZ000397R1</b>	
<b>PCO 010</b> , PROFIBUS DP connector, standard, up to 1,5 MBd connection	<b>3BDZ000370R1</b>	
<b>PCO 011</b> , PROFIBUS DP connector with ON/OFF switchable termination resistor, up to 12 MBd connection	<b>3BDZ000371R1</b>	
<b>PCO 012</b> , PROFIBUS DP connector with ON/OFF switchable termination resistor and test equipment jack, up to 12 MBd connection	<b>3BDZ000372R1</b>	

You can order the Redundancy Link Module RLM01 also via the ABB Onlinestore  
<http://www.abb.de/onlinestore>

*For more information of RLM01, contact us at [fieldbus@de.abb.com](mailto:fieldbus@de.abb.com)  
 For the latest information on ABB visit us on the World Wide Web at <http://www.abb.com/control>*

Our worldwide staff of professionals is ready to meet *your* needs for process automation.  
 For the location nearest you, please contact the appropriate regional office:

Automation Technology Products  
 Wickliffe, Ohio, USA  
[www.abb.com/processautomation](http://www.abb.com/processautomation)  
 email: [industrialitsolutions@us.abb.com](mailto:industrialitsolutions@us.abb.com)

Automation Technology Products  
 Västerås, Sweden  
[www.abb.com/processautomation](http://www.abb.com/processautomation)  
 email: [processautomation@se.abb.com](mailto:processautomation@se.abb.com)

Automation Technology Products  
 Mannheim, Germany  
[www.abb.de/processautomation](http://www.abb.de/processautomation)  
 email: [marketing.control-products@de.abb.com](mailto:marketing.control-products@de.abb.com)