

### Features and Benefits

- **Maximum Return on Investment**  
New generations of software and system components provide increased operating efficiency, lower cost and extended system life. ABB offers low-risk evolution and upgrade strategies to assure maximum return on investment while enhancing equipment availability and performance.
- **Investment protection through enhancement**  
Reuse of existing controllers, I/O, and field wiring with newer operator interfaces and advanced applications, not only saves capital expenses but also provides the benefit of improved productivity.
- **Nonstop production for maximum profit**  
Advant Controller 160 provides the highest level of plant availability through redundancy in all levels.
- **Reducing time to decision and action**  
800xA Process Portal, the industry's most intuitive system interface, provides consistent access to enterprise wide data. Personalized workplaces to fit the job function, and easy and consistent navigation result in timely and informed decision making.
- **Engineering for maximum performance**  
The comprehensive, multi-user engineering tool provides functions for graphical engineering instead of programming. Efficient integration of field devices via the PROFIBUS interface is a matter of course.



In today's business environment, there is a need for continuous productivity improvements to be competitive in the market. Traditional process control systems achieved high process availability, reliability, and process quality. But today, more is needed to be competitive. Advant Controller 160 enhanced with Industrial IT System 800xA paves the way to reach that goal.

Advant Controller 160 is a proven process control system for demanding applications in dedicated industries. The wide range of Advant Controller 160 references includes power stations, nuclear reactor protection systems, sugar manufacturing, and many more. Advant Controller 160's scalable redundancy enables maximum process availability. Powerful controllers are networked via a redundant bus system. In addition, they constitute the links to I/O modules, field devices, operator stations, and engineering tools. However, Advant Controller 160 is not only a traditional control system, but was and is continuously improved and enhanced to remain a state-of-the-art system allowing our customers to be more competitive. Advant Controller 160's capabilities may be now be extended by incorporating 800xA's growing set of Industrial IT applications. That's why a customer's present plant is well equipped to adapt to new opportunities and market requirements. Advant Controller 160 perfectly protects the investments.

ABB has continued the aim to protect our customers' investments: Advant Controller 160 as best-in-class process control system for dedicated markets with Industrial IT Extended Automation System 800xA featuring best-in-class productivity enhancement software such as 800xA Operations or Information Management. The enabling technology to leverage these System 800xA applications is a product called AC 100 Connect. With Industrial IT System 800xA and Advant Controller 160, the customer is provided with the technology and solutions needed to achieve a sustainable competitive advantage by enabling the plant to perform smarter and better at substantial cost savings.

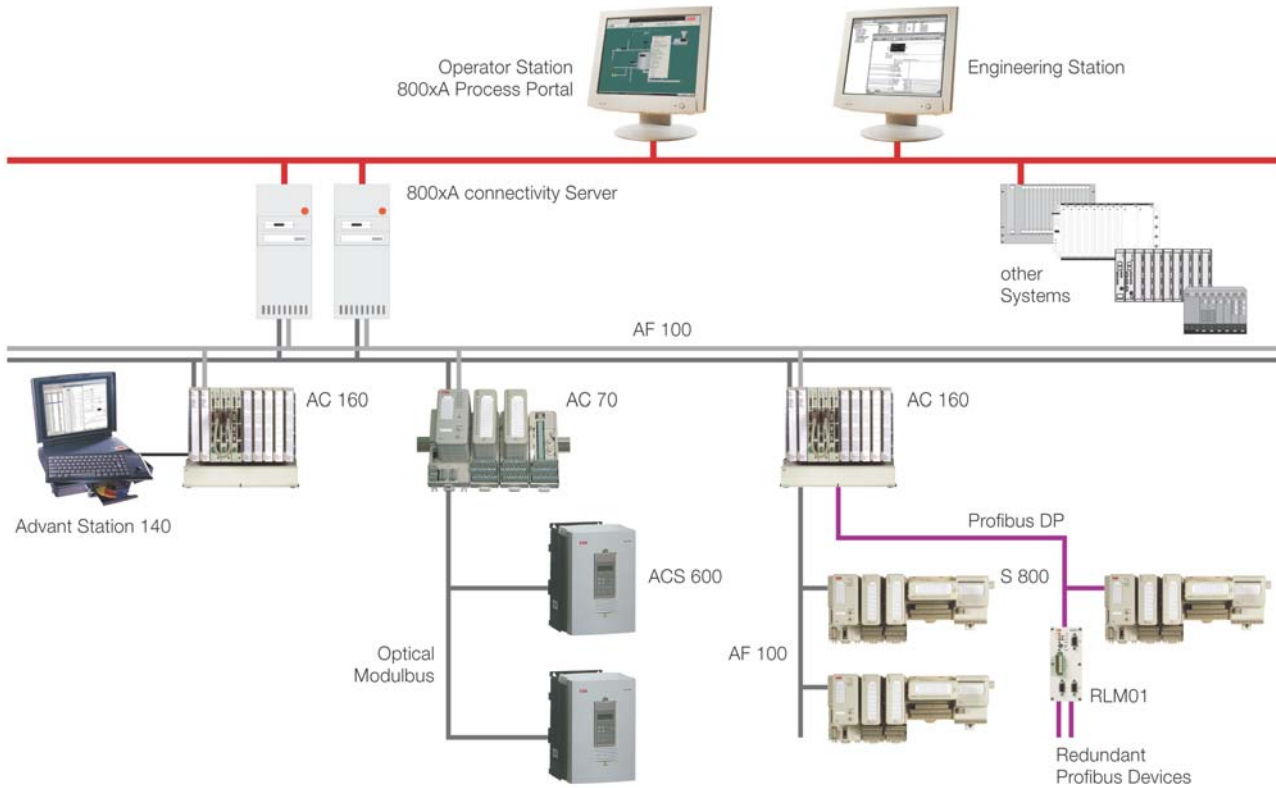

Figure 1. AC 160 System Structure

## The Industrial IT 800xA Advant Controller 160 System at a Glance

### Control & I/O

Customers have the freedom to choose the controller type that best fits their application. The customer can select between the rack based S600 I/O and the rail mounted S800 I/O as remote I/O. The S800 I/O could be connected either via our own fast and reliable AF100 bus and/or via Profibus DP.

AC 160 offers redundancy on all important levels for maximum availability. The powerful AC 160 controllers include a comprehensive scope of dedicated process functions, redundant interfaces to S600 and S800 I/O.

Integration of the 800xA Control & I/O is also well supported. AC 160 Controller, and AC 800M Controller can be operated with the same 800xA Process Portal operator interface.

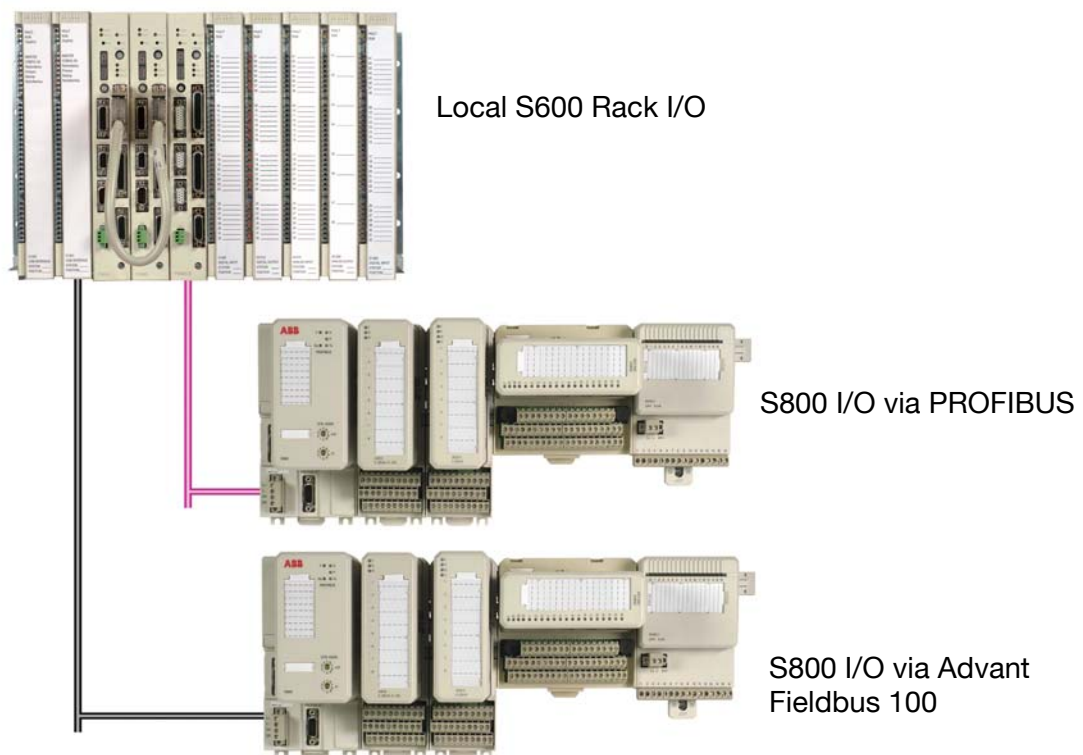

**Figure 2.** AC 160 Controllers and I/O

See following document for further details:

- 800xA Control & I/O Overview
- Product Guide AC 160

## Engineering

The Engineering Tool Control Builder A is a comprehensive, efficient multi-user engineering tool for planning, engineering, commissioning, diagnostics, and maintenance of an automation project. Parallel engineering of planning and operating phases are supported. Control Builder A provides a function-chart-oriented user interface and well integrated field device configuration for PROFIBUS.

The customer is provided with libraries, which include proven and tested solutions for dedicated industries. These libraries are available as function blocks and can be supplemented, modified and adapted according to the customer's needs. These new solutions are then available as standard templates for a project and can be reused.

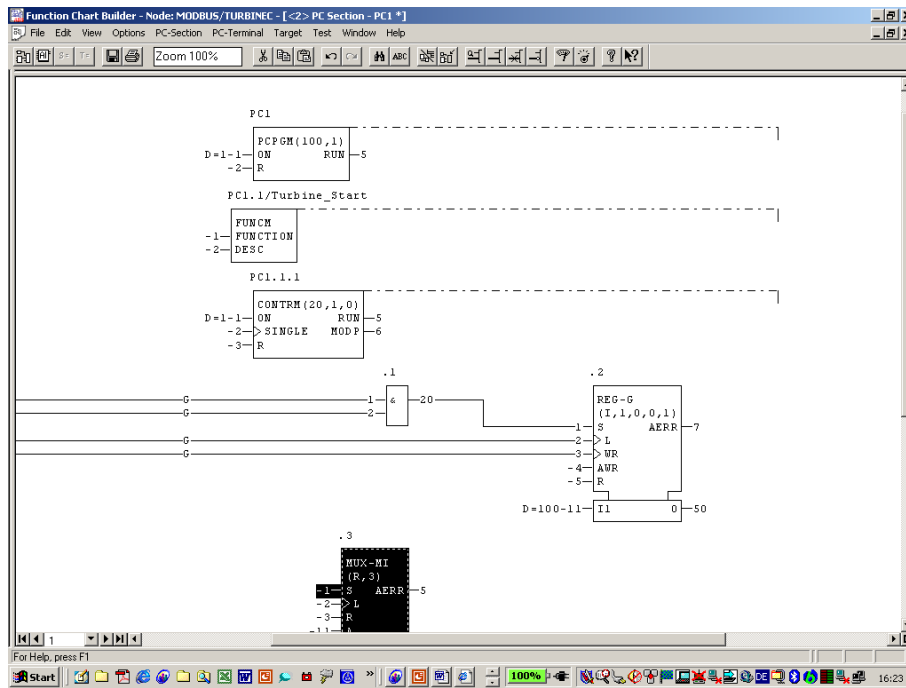

Figure 3. Function Planning with Control Builder A

For more details about Control Builder A see the Control Builder A Brochure.

## Operations

The industry's most intuitive operator software provides consistent access and interaction with data from multiple control and I/O to plant and enterprise information. 800xA Process Portal includes:

- Extensive operator functionality for handling normal and abnormal conditions including alarm and events, reporting functions, and messenger support
- Customized operator environment to meet individual user needs
- Quick, flexible and secure access to relevant displays and information
- Rapid and consistent access to smart field devices, asset optimization tools, information management systems, safety systems, and MES applications.

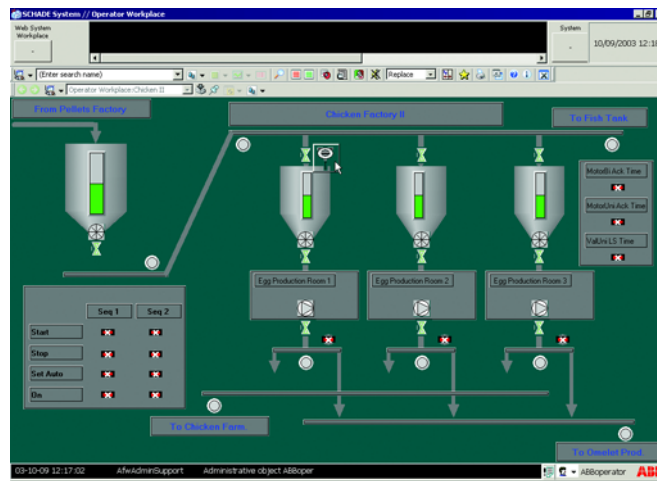

**Figure 4.** 800xA Process Portal

For more details see the 800xA Operations Overview.

## Information Management

Powerful information management software application designed to collect, store, retrieve and present historical, process and business data. Enhances the usefulness of data from all operations within the enterprise to help identify bottlenecks and operating anomalies as well as analyze under-performing assets that adversely impact profits and productivity.



Figure 5. Information Management Workplace

For more details see the 800xA Information Manager Overview.

## Asset Optimization

800xA Asset Optimization software exploits the wealth of field resident information accessible through fieldbus and higher-level systems to assess and document equipment conditions in real-time and enable personnel to schedule maintenance accordingly.

Advant Controller 160 provides an interface to 800xA Asset Optimization for tag-based signals. Additionally, software seamlessly integrates plant's maintenance management systems to greatly reduce costly corrective maintenance and time consuming preventive maintenance.

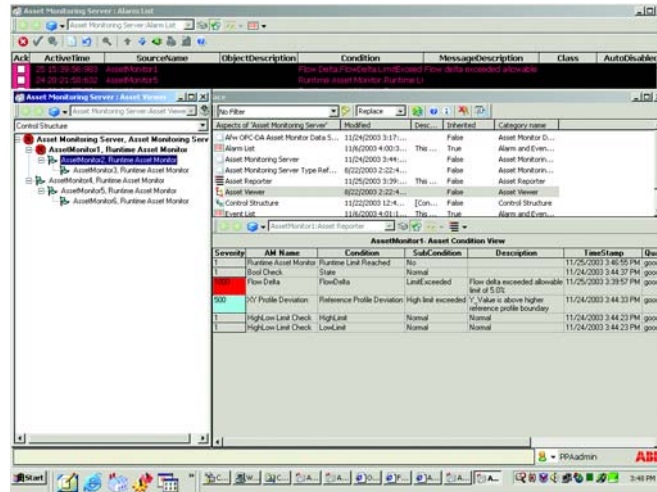

Figure 6. 800xA Asset Optimization Workplace

For more details see the 800xA Asset Optimization Overview.

*For the latest information on ABB visit us on the World Wide Web at <http://www.abb.com>*



Automation Technologies  
Västerås, Sweden  
Phone: +46 (0) 21 34 20 00  
Fax: +46 (0) 21 13 78 45  
[www.abb.com/controlsystems](http://www.abb.com/controlsystems)  
e-mail: [processautomation@se.abb.com](mailto:processautomation@se.abb.com)

Automation Technologies  
Wickliffe, Ohio, USA  
Phone: +1 440 585 8500  
Fax: +1 440 585 8756  
[www.abb.com/controlsystems](http://www.abb.com/controlsystems)  
email: [industrialitsolutions@us.abb.com](mailto:industrialitsolutions@us.abb.com)

Automation Technologies  
Mannheim, Germany  
Phone: +49 (0)1805 26 67 76  
Fax: +49 (0) 1805 77 63 29  
[www.abb.de/controlsystems](http://www.abb.de/controlsystems)  
email: [marketing.control-products@de.abb.com](mailto:marketing.control-products@de.abb.com)

3BDD013113R0101 Rev A

© Copyright 2004 ABB. All rights reserved.

Specifications subject to change without notice. Pictures, schematics, and other graphics contained herein are published for illustration purposes only and do not represent product configurations or functionality. User documentation accompanying the product is the exclusive source for functionality descriptions.

The Industrial<sup>IT</sup> wordmark, Aspect Objects, and all above-mentioned names in the form XXXXX<sup>IT</sup> are registered or pending trademarks of ABB. All rights to other trademarks reside with their respective owners.