

Calculation and choice of setting values for protection terminals in series compensated system in Venezuela

1 Introduction

Series compensation is introduced in Venezuela in the 400 kV systems in order to enable increased transfer capacity. The series capacitor banks are located in the substations Yaracuy and El Tablazo as seen in the figure.

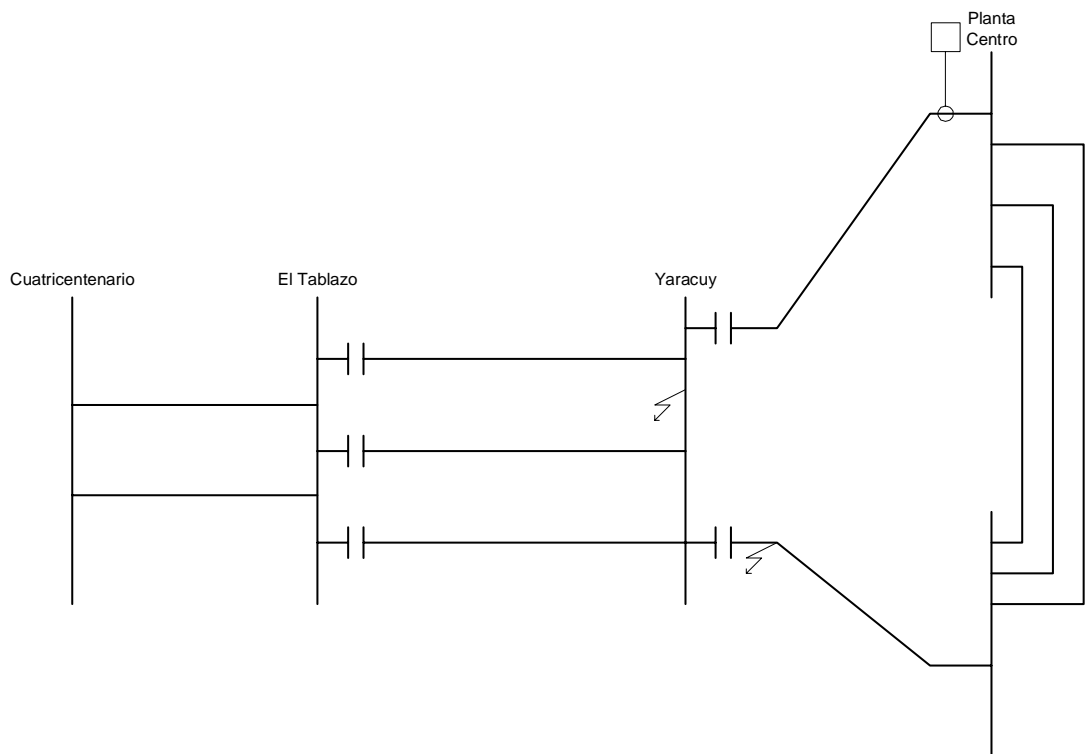

Figure 1. Yaracuy and El Tablazo substations

2 Application

On the series compensated lines and on some of the other lines, line protection terminals of type REL 531 were introduced. REL 531 involves a number of protection functions. One important feature of REL 531 is that the distance protection has a special logic to handle faults resulting in voltage inversion in the relay point. Conventional distance protections will have difficulties to get correct directional measurement to the fault point. This is handled by REL 531 and thus unwanted protection function as well as failure to clear the fault will be avoided.

The setting of the protection functions in series compensated networks involves some additional considerations compared to the normal setting procedures. Therefore ABB Power Technologies was engaged to make calculation and to give proposals for the setting parameters of the line protections.

In the setting calculations and in the choice of setting parameters the following facts had to be considered.

The series capacitor banks are protected from over voltage due to fault current through the series capacitor bank by means of Metal Oxide Varistors (MOV:s). When a short circuit current flows through the capacitor bank the voltage over the bank will reach dangerous values. At a certain protection level (voltage) the MOV will take the whole current flow, and thus short circuit the capacitors. The combination of the capacitor and MOV conducting during part of the period can be seen as equivalent impedance, dependent on the fault current level as shown in the figure.

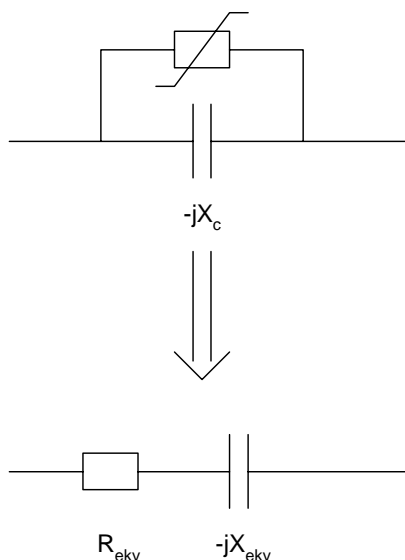

In the calculation of faults at critical fault points iterative calculations were made to get the correct capacitor bank impedance for the actual fault current.

The series capacitors can give rise to sub synchronous oscillations in the system that will influence the apparent impedance seen by the distance protection. This is considered in the setting calculations.

The parameter settings shall give acceptable fault clearance for all relevant switching states in the network, i.e. with series capacitor banks both in operation and taken out of operation. For the different settings the "worst case" must be studied.

For each line a comprehensive report was written, describing the chosen parameter settings and the calculations and special considerations made in order to get fault clearance with a high degree of security and dependability.

For more information please contact: