

Method for improved security at operation of switching devices

1 Introduction

For interlocking evaluation in a substation, the position information from switching devices, such as circuit breakers, disconnectors and earthing switches can be required from the same bay or from several other bays. When information is needed from other bays, it is exchanged over the communication bus between the distributed Intelligent Electronic Devices (IEDs) in a Substation Automation system. The problem that arises, even at a high speed of communication, is a space of time during which the information about the position of the switching devices are uncertain. The interlocking function uses this information for evaluation, which means that also the interlocking conditions will be uncertain.

To ensure that the interlocking information is correct at the time of operation, a unique reservation method is available in the IEDs. With this reservation method the operation will temporarily be blocked for all switching devices in other bays, which switching states are used for evaluation of permission to operate. Actual position indications from these bays are then transferred over the serial bus for evaluation in the IED. After the evaluation the operation can be executed with high security.

2 Application

The application can best be illustrated with an example:

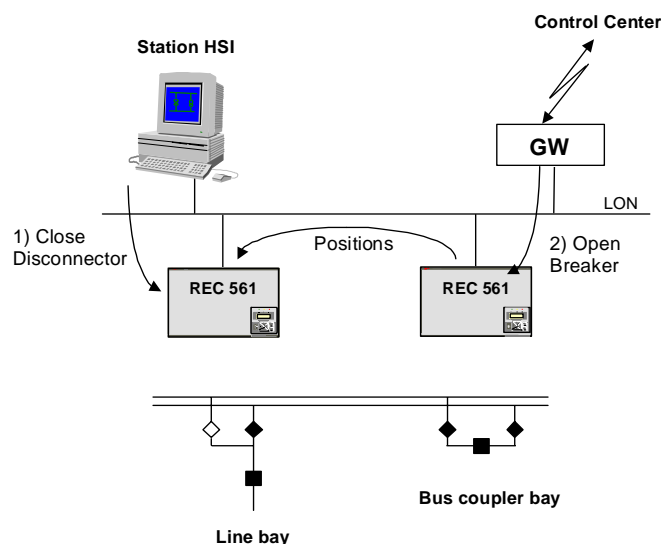

Figure 1 Operation from different workplaces

To close the busbar disconnector in the line bay, the bus coupler must be closed to fulfill the interlocking conditions. These position indications are transferred from the bus coupler to the line bay cyclically or at change of status. If the bus coupler breaker is opened from another workplace e.g. from Control Center, according to Figure 1, during the selection command of the busbar disconnector, there is a risk to evaluate the interlocking conditions with wrong information and then give permission for an incorrect closing of the busbar disconnector. Even if the position indications are sent very fast from the bus coupler bay to the line bay there exists a time gap with uncertain

information. The time gap may vary depending on the transmission speed and the transmission principle between the IEDs.

This problem also exists for conventional relay logic, but then the time gap is in the order of 10 ms, which has been commonly accepted from the security point of view.

3 Solution

ABB has a patented method to eliminate the time gap. The IEDs are provided with this solution together with the interlocking functions and is here called the reservation method.

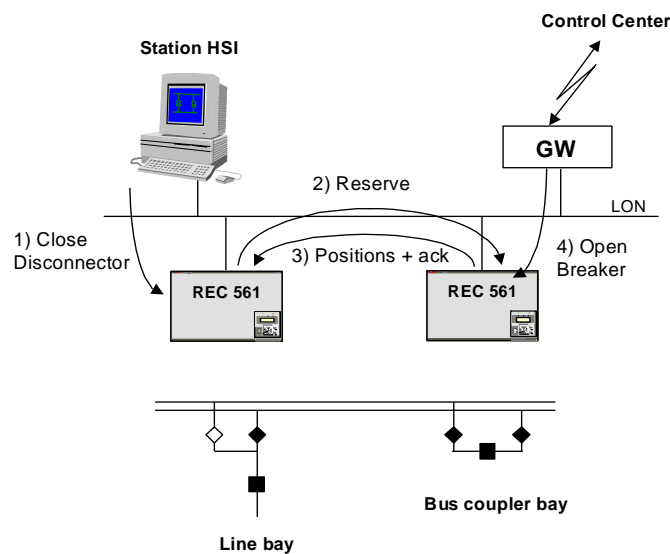

Figure 2 Operation procedure with the reservation method

Commands for operation of the switching devices in a bay may come from an operator via a Station HSI, from the Control Center, locally via mimic panel or else from some automatic function. Independently of where the request for operation originates from, the relevant switching device control module in the IED is requested to initiate a procedure to find out whether all the necessary permission conditions for operation are fulfilled and to make the necessary reservations, that is, prepare the execution of the operation. To simplify the explanation, Figure 2 is used to describe the procedure of operation according to the following steps:

1. The selection command in order to close the busbar disconnector in the line bay initiates a request to reserve the bus coupler bay.
2. This request to reserve is sent to the bus coupler bay. If the bus coupler bay is not reserved by some other function, this reservation will block the switching devices included in the bus coupler bay, so these cannot be operated. If the bus coupler bay is already reserved, the command is cancelled.
3. If the bus coupler bay is not reserved, it responds to the line bay with a message containing an acknowledgment that the bay is reserved, so no operations are allowed, together with all position information from the bus coupler bay. After this response the close command for the disconnector in the line bay can be performed in a secure way with correct interlocking information, because the bus coupler devices are temporarily blocked for manual operation.
4. After the close execution of the disconnector in the line bay, the reservation is cancelled and the bus coupler bay is released for operation.

As mentioned above, this was just an example. The reservation method can be implemented also for other arrangements in a corresponding way, where the interlocking function is dependent on the switching states in other bays for the evaluation.

4 Configuration

The IED configuration is illustrated in Figure 3 and is made for arrangements with a bus coupler bay in one REC 561 and a line bay in another REC 561 as a simplified example. The arrangement can be seen in the Figure 1 and Figure 2 above. The configuration can easily be extended for more bays.

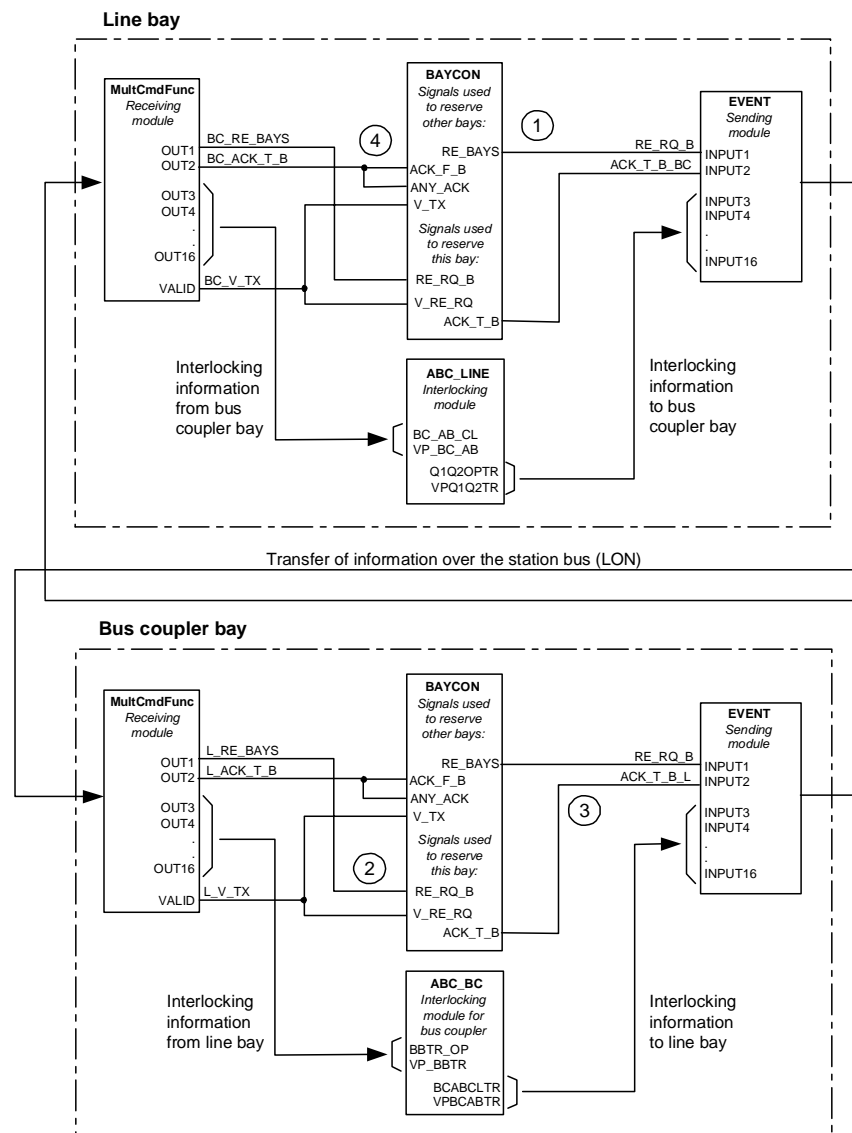

Figure 3 Configuration example for the reservation function in REC 561

The command sequence to operate a busbar disconnector is performed according to Figure 3. Note that only signals involved in the reservation process are included in the figure. The numbers in the figure refer to the following steps:

1. When a selection of the disconnector in the line bay is made from the operator workplace (HSI), the output RE_BAYS (reserve other bays) in function block BAYCON is activated in order to reserve other bays. This signal is sent over the LON-bus to reserve, in this example, only the bus coupler bay.

2. The signal is received in the bus coupler bay and connected to input RE_RQ_B (reservation request) in BAYCON. At activation of this input, BAYCON checks if this bay is already reserved, i.e. busy with another operation. The signal connected to input V_RE_RQ (valid reservation request) comes from the output VALID on the receiving module (multiple command function). This output detects if there is a transmission problem over the LON-bus and consequently invalid output signals from the receiving module.
3. If the bus coupler bay is not reserved, the bay will be reserved and sends an acknowledgement (ACK_T_B) back to the line bay. At the same time and in the same sending module (event function) where the acknowledgement is located, the position information from the interlocking module is included.
4. The position information is received in the line bay and used for evaluation of the interlocking conditions. The acknowledgement from the bus coupler bay (ACK_F_B and ANY_ACK) releases the possibility to execute the command.

The meaning of the inputs and outputs for included interlocking modules in the figure is:

Interlocking module for line bay (ABC_LINE)

BC_AB_CL	A bus coupler connection exists between busbar A and B
VP_BC_AB	Valid switch status for the bus coupler apparatuses connected between busbar A and B
Q1Q2OPTR	Either busbar disconnector Q1 or Q2 or both are open
VPQ1Q2TR	Valid switch status for Q1 and Q2 (open or closed)

Interlocking module for bus coupler bay (ABC_BC)

BBTR_OP	No busbar transfer is in progress concerning this bus coupler
VP_BBTR	Valid switch status for all apparatuses involved in the busbar transfer
BCABCLTR	A bus coupler connection exists between busbar A and B
VPBCABTR	Valid switch status for the bus coupler apparatuses connected between busbar A and B

For more details regarding the configuration see the Application Manual for REC 561.

5 Conclusions

In a distributed Substation Automation system with information exchange between the IEDs a time gap with uncertain information can arise. Especially for interlocking, this information can result in dangerous situations. ABB has a patented method to eliminate this time gap. With use of REC 561 including a configuration described above an improved security at operation of switching devices can be attained.

For more information please contact:

ABB Power Technologies AB
Substation Automation Products
721 59 Västerås, Sweden
Phone: +46 21 342000, Fax: +46 21 324223
www.abb.com/substationautomation