

Control^{IT}

Features and Benefits

- Distributed I/O system for zone 1 and zone 2 applications
- Modular design, with hot-pluggable modules
- Redundancy in power supply and communication interface
- HART pass through, access to parameter settings, states and variables
- Configuration, communication and diagnosis via PROFIBUS-DP
- FDT/DTM system integration or import of GSD file

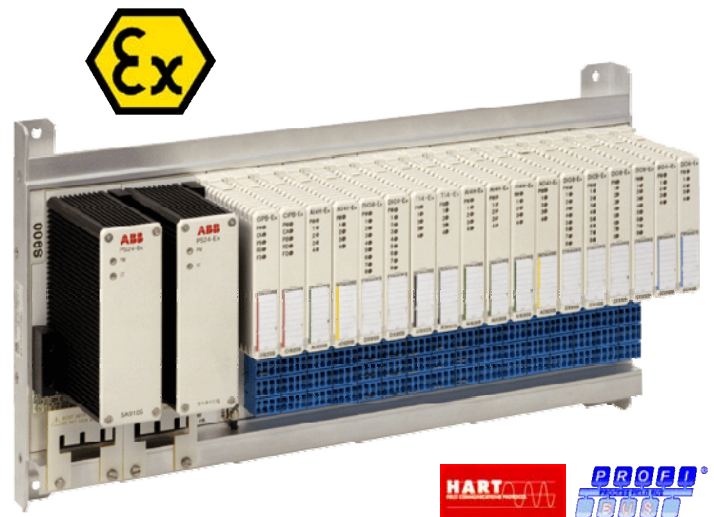

Function

The S900 Remote I/O System is for use in hazardous and non hazardous areas. It provides various input and output modules for connection of digital and analog field instruments.

ABB

Notice

The information in this document is subject to change without notice and should not be construed as a commitment by ABB. ABB assumes no responsibility for any errors that may appear in this document.

In no event shall ABB be liable for direct, indirect, special, incidental or consequential damages of any nature or kind arising from the use of this document, nor shall ABB be liable for incidental or consequential damages arising from use of any software or hardware described in this document.

This document and parts thereof must not be reproduced or copied without written permission from ABB, and the contents thereof must not be imparted to a third party nor used for any unauthorized purpose.

The software or hardware described in this document is furnished under a license and may be used, copied, or disclosed only in accordance with the terms of such license.

Copyright © 2008 by ABB
All rights reserved

Issue date: 2008-07-01

Document number: 3BDD010420R0601

Trademarks

Registrations and trademarks used in this document include:

Windows	Registered trademark of Microsoft Corporation.
ActiveX	Registered trademark of Microsoft Corporation.
PostScript	Registered trademark of Adobe Systems Inc.
Acrobat Reader	Registered trademark of Adobe Systems Inc.
Industrial IT	Trademark of ABB.
PROFIBUS	Registered trademark of the PROFIBUS User Organisation.

	Page
Introduction	
System description	5
General data	9
System architecture	9
Housings	
Field housing	10
Compact box.....	11
Termination unit	
Extended termination unit	13
Power supplies	
Power supplies for termination unit.....	16
Power supplies for compact box	22
Power conditioner	25
Coupling modules	
Communication interface for PROFIBUS-DP V1	26
Digital modules	
Digital I/O	27
Solenoid driver	28
Relay output.....	29
Frequency modules	
Frequenzy input	30
Analog modules	
Analog input.....	31
Analog input HART, active.....	32
Analog input HART, passive	33
Temperature	34
Analog output.....	35
Analog output, isolated	36
Analog output HART.....	37
Ordering information	
S900 Ex devices Zone 1	40
S900 Ex devices Zone 2	41
S900 Safe area devices.....	42
Accessories	
Fieldbus isolating repeater	44
Accessories and software	45
Mounting and installation	
Coding	48
Mounting in hazardous areas.....	49
Safety and precautions	49

System description

S900 provides the input and output modules needed for intrinsically safe field signal connection. The field signals are digitized in every S900 functional module, electrically isolated, and then output via an internal serial bus. The communication interface converts the signals to adapt them to the standardized PROFIBUS-DP V1 fieldbus protocol.

Supervisory process control systems, DCS or SCADA systems use an intrinsically safe fieldbus to communicate with the communication interface. A single fieldbus network suffices for configuring the individual S900 stations, for cyclic data exchange, for all acyclic services, and for communication with HART®-compatible field instruments. All functional modules can be replaced easily and quickly in the installation or maintenance phase. The functional modules and the – optionally redundant – communication interfaces of systems placed in Zone 1 can be removed and plugged in while operation is running. Only the primary power for the plug-in type power supply modules requires increased safety in order to improve the performance.

Integrated encapsulated switch-off mechanisms allow for hot swapping of the power supplies. Due to its little space requirements and robust design and its environmentally ruggedized case, the S900 Remote I/O System is the best, cost-saving solution for use on site, in hazardous Zone 1 or Zone 2 areas (ATEX).

Various installation solutions for different tasks

The S900 components are arranged in a passive termination unit for direct mounting in a junction box. The termination unit contains the internal redundant communication interface and all connectors for the field circuitry, communication and primary power. The functional modules are plugged in the appropriate slot of the termination unit.

Two termination unit versions are available: a redundant one with slots for two power supplies and two communication interfaces and 16 slots for the different functional modules (type TU921), and a non-redundant one (integrated in a field housing type CB220) with a maximum of 4 slots. Digital functional modules are designed for up to 8 channels, and analog functional modules for up to 4 channels. Thus, up to 128 digital or up to 64 analog channels are possible for each fieldbus node when using a redundant termination unit. It is also possible to combine different functional modules. Up to 125 fieldbus nodes can be connected to a single fieldbus network. This means that up to 10,000 inputs or outputs can be handled by single S900 network. Extensions beyond this scope depend upon the fieldbus type used.

No external signal adaptation or routing required

S900 provides various input and output modules: Analog input modules with or without integral transmitter supply, or with direct temperature measuring input for 2-, 3- or 4-wire resistance thermometers or thermocouples with internal cold junction compensation. Analog output modules for direct positioner or actuator control. Solenoid driver units or NAMUR inputs for intrinsically safe and short-circuit-proof power supply of digital field instruments.

Additionally, options are available for critical applications, allowing for channel-wise electrical isolation of the inputs and outputs. S900 permits direct connection of the entire field level through only 2 lines. As no separate routing, power supply or fusing is needed, the installation cost is reduced considerably.

Consistent configuration

Just like local I/O modules, the individual S900 Remote I/O stations can be configured directly, using the engineering tool integrated in the Distributed Control System (DCS). The Device Type Manager (DTM) exactly “knows” the functionality and parameters of the individual functional modules and their interface to the bus. Besides the module configuration, the DTM also provides for forcing (simulation) of the inputs and outputs and for display of the diagnosis messages.

Due to the standardized FDT/DTM interface the DTM can be easily integrated in the configuration tool of the DCS. Since the DTM belongs to the instrument and not to the DCS, the user has to get familiar with the operating procedure only once. The complete configuration and all parameters are automatically loaded into the S900 stations when the bus network is starting up or upon replacement of a hardware component. So, this is a real “plug & play” system.

In consequence, there is no local service interface for the communication interface, since it is no longer needed. The configuration and parameter data is exclusively visualized and updated by the DTM. The data is stored in the central database of the engineering tool. Thus, system-wide data consistency is ensured. The efforts needed for commissioning and trouble-shooting are reduced to the minimum. Of course, it is alternatively possible to use the GSD file for commissioning/putting into operation.

System features

S900 is a remote I/O system for use in hazardous areas. It provides bus-compatible local inputs and outputs (protection class IP20) for connection of digital and analog field instruments. Due to its degree of explosion protection it can be mounted in both hazardous areas (zone 1 and zone 2 / ATEX) and safe areas.

The system consists of a termination unit accommodating the power supply units, the communication interfaces, and the I/O modules. The passive termination unit ensures power distribution and data transfer, and also provides the connection platform. The power supply units reliably power the entire system. One power supply unit is sufficient for normal operation. A second (redundant) power supply unit can be added, to improve the system availability (for termination unit TU921). The communication interface controls all data traffic between the I/O modules and the distributed control system (DCS) or the programmable logical controller (PLC). The communication interfaces can also be used in redundancy mode (line redundancy and station redundancy with termination unit TU921).

S900 Remote I/O System for hazardous areas

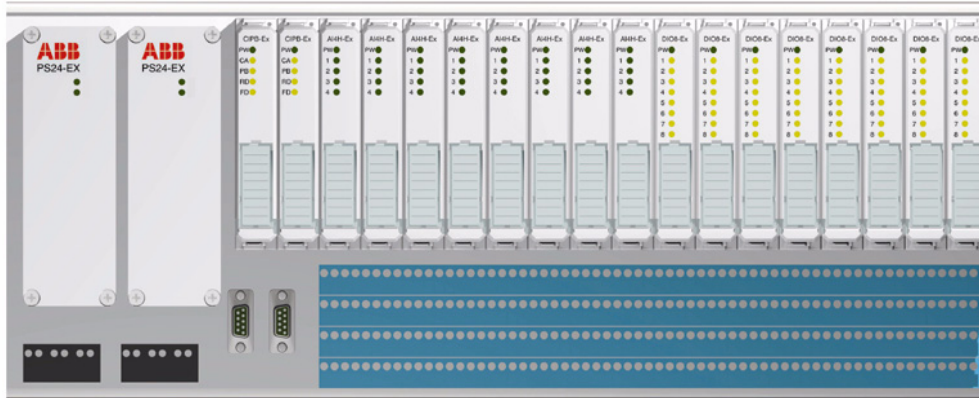

S900 Remote I/O System with a redundant power supply unit, a redundant communication interface, and 16 I/O modules (front view)

The termination unit is accommodated in a suitable field housing (junction box) to protect it from environmental exposure. When mounting the unit in a hazardous area you have to use a field housing with increased safety (EEx-e). Appropriate ready-made S900 field housings are available. The S900 Remote I/O System is powered/connected via sufficiently protected terminals on the termination unit, with increased safety EEx-e. The power supply units, the communication interfaces, and the I/O modules are plugged into the termination unit and locked automatically. The power supply modules have a built-in shut-off mechanism with automatic locking and can be plugged/removed under power (even in zone 1 / ATEX), although the EEx-e supply in the primary circuit is still active in this case. As a result, the S900 Remote I/O system does not require a flame-proof enclosure or pressurized housing and, therefore, is easy to handle.

The termination unit and the power supply unit(s) ensure intrinsically safe power supply of the communication interfaces and up to 16 I/O modules. The mounting termination unit provides all internal connections. Thus, only the peripheral units need to be connected by the user. Also, hot swapping of the communication interfaces and I/O modules is possible, i.e. these units can be connected or removed during operation. This ensures easy replaceability of all active components, and a high degree of flexibility and user-friendliness.

Field instruments complying with protection class EEx ia IIC can be connected to the Ex I/O modules. Up to 16 I/O modules can be run on the same termination unit. Each I/O module is designed for connecting 2, 4, 6 or 8 field instruments, depending on the respective model. The I/O modules and the underlying field instrument level are powered via the termination unit. All intrinsically safe modules are self-feeding and short-circuit proof. No separate routing level with additional power supply and individual fusing is required.

HART® communication in the field with all analog S900 I/O modules is possible via a PC or a hand-held terminal. In addition, the special HART® variants allow for a consistent HART® communication up to the distributed control system (DCS). Cyclic transmission of all secondary HART® variables, HART® diagnosis, and (acyclic) configuration of all HART® devices are possible.

The S900 I/O modules are slot-addressed and, therefore, do not require any settings on the modules themselves. The PROFIBUS address is set via three coding switches on TU921 and two coding switches on CB220.

The S900 communication interface, the I/O modules, and the connected HART® devices are configured and parameterized via a fieldbus network. No additional configuration and parameterization network is required. The communication interface and the I/O modules have built-in LEDs allowing for "on site" diagnostics. All diagnostic and status indicator LEDs comply with DIN EN 60073 and NAMUR NE44. In addition, PROFIBUS diagnosis down to channel-specific error messages is possible via the communication bus.

Required S900 components

The S900 Remote I/O System for hazardous areas in its minimum hardware configuration (based on termination unit TU921S) consists of the following components:

Type TU921S Catalog No.	Extended Termination Unit / TU16R-Ex 3KDE175111L9210
Type SA920S Catalog No.	Power Supply 24 V DC 3BDH000602R1
Type BP901S Catalog No.	Power Supply Filter (only for SA910S / not required for the power supplies type: SA920X, SA910N, SA910B, SA911N, SA911B, SA911S) 3KDE175831L9010
Type CI920S Catalog No.	Communication Interface / CIPB-Ex 3BDS014111
Type BP910S Catalog No.	Sub D connector EEx i for PROFIBUS-DP 3KDE175831L9100
Type DX910S Catalog No.	Digital I/O Module / DIO-Ex 3KDE175311L9100
Type BI9xxS Catalog No.	Fieldbus isolating repeater / (see ordering information for accessories) 3KDE175831L9xxx

If required, a 230 V AC / 24 V DC power supply unit must be provided by the customer to ensure 24 V DC supply of the S900 Remote I/O System.

For more installation details refer to the installation guide on the CD910 (Catalog No. 3KDE175839L9100). The CD910 will be delivered with every ordered TU921 or CB220.

Requirements on PLC/DCS master systems

S900 Remote I/O can be connected to systems with a PROFIBUS DP master.

The PROFIBUS-DP V0 services provide the following S900 Remote I/O functions:

- Configuring/ setting parameters of the S900 Remote I/O station by restarting all slaves.
- S900 diagnosis messages
- Reading HART[®] secondary variables from the connected field instruments
- Reading HART[®] diagnosis from the connected field instruments through PROFIBUS diagnosis messages.

To be able to use the full range of functions provided by the S900 Remote I/O System, the master has to support additional functions. Modern, state of the art master systems support PROFIBUS-DP V1 services, and are capable to (re)load user-defined and configuration parameters while the system is running, without affecting other slaves or requiring to restart the network.

PROFIBUS-DP V1 services allow you to

- simulate (force) the S900 inputs and outputs
- configure HART[®] field instruments connected to the system

You can select special user-defined and configuration parameters and (re)load them while the system is running to

- change the parameters of the communication interfaces or of individual I/O modules
- add more S900 Remote I/O groups
- add, remove or replace S 900 I/O modules .

All I/O modules not involved in these parameter or configuration changes continue cyclic communication. The S900 outputs hold their values/states while the master is downloading the parameters.

Modern master systems meeting the requirements stated above are, for example

- System 800xA
- Melody / AC870P
- Freelance 800F
- other systems

System features

Number of PROFIBUS nodes

With PROFIBUS-DP a maximum of 32 nodes (including the master and the class 2 configuration tool, if applicable) can be connected to a segment. A maximum of 10 nodes per segment can be connected to the intrinsically safe PROFIBUS-DP. When using repeaters, you can connect up to 126 nodes to a DP master.

The specified transmission rate and the max. permissible cable length of the segments (see installation guide) must be observed. For example, a cable length of 400 m (1314 ft) is permissible for a network with a transmission rate of 500 Kbauds. Longer cables are possible when using FO cables.

Number of I/O modules

In accordance with the PROFIBUS standard up to 240 user parameters are available for parameterizing the S900 System. The S900 System uses one byte per module in Mode 1, and six bytes per module in Mode 2 for the module parameterization. The 16 slots can be assigned as required.

The total quantity of I/O data must not exceed 216 bytes. If no HART[®] variables are to be transmitted, no system limitations result from this, since the max. possible I/O data quantity is 128 bytes, with up to 8 bytes per module and a maximum of 16 modules. Thus, an S900 Remote I/O Station can be equipped with up to 16 I/O modules.

However, the max. number of transferable HART[®] secondary variables is limited, since the maximum quantity of I/O data is 240 bytes. The max. number of HART[®] variables can be derived from the table below. If the system is configured using a configuration tool based on the FDT/DTM technology, the DTM will monitor the system limits (see the DTM manual).

Modules	I/O Modules		HART devices
	out bytes	in/status bytes	in bytes
CI920 ⁽¹⁾	0	0	0
AI930 ⁽¹⁾	0	8	0/4/16/32 ⁽²⁾
AO930 ⁽¹⁾	8	0	0/4/16/32 ⁽²⁾
AI950 ⁽¹⁾	0	8	0
DX910 ⁽¹⁾	1	1	0
DI910 ⁽¹⁾ with Status	1	2	0
DO910 ⁽¹⁾	1	0	0
DP910 ⁽¹⁾	2	8	0

I/O data of various I/O modules

¹⁾ stands for S900 S/B/N modules

²⁾ 0...8 (0/4/16/32) HART variables per channel can be selected here

Calculation of the total I/O data example

Modules: 1 x CI920, 6 x AI930, 4 x AO930, 6 x DX910 with status

Total of out bytes	= 6 x 0 + 4 x 8 + 6 x 1	= 38
Total of in/status bytes	= 6 x 8 + 4 x 0 + 6 x 2	= 60
Total of I/O bytes	= 38 + 60	= 98
Number of still available bytes	= 216 - 98	= 118
Number of possible HART [®] variables	= 118 / 4	= 29

Cycle time

The PROFIBUS master defines the transmission rate used in the system. The internal cycle time is 5 ms for processing 128 digital signals and 20 ms for processing 64 analog signals. The response time of the entire system depends on the total I/O data quantity of all PROFIBUS nodes and the processing speed of the supervisory system.

S900 Remote I/O System for hazardous areas

The S900 output data are synchronized with the higher-level bus. Therefore, the internal cycle time only needs to be considered once.

The following approximation formula is valid: $T_R = T_i + 2 \times T_B + T_S$

- T_R = response time
- T_i = internal cycle time
- T_B = cycle time of the higher-level bus
- T_S = cycle time of the DCS

With a bus cycle time of 5 ms and a DCS cycle time of 5 ms, a response time of $T_R = 5 + 2 \times 5 + 5 = 20$ ms results from this for the 128 digital signals.

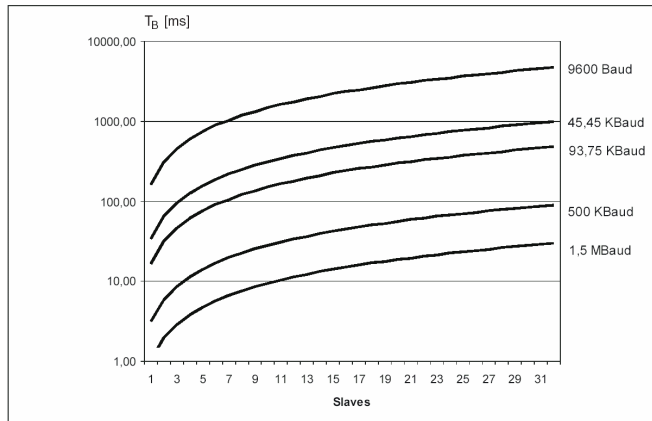

PROFIBUS DP cycle time

For every S900 station (slave): 80 bytes input, 20 bytes output (corresponding to 32 digital output, 48 digital input with status, 16 analog input, 8 analog output, 12 secondary HART variables).

I/O module power supply

The S900 power supplies are designed for two communication interfaces and up to 16 I/O modules of any type. No system limitations result from the selection of typical combinations of the module types DX910, AI930, AI950 and DO910. The power supply dimension on the secondary side can cause a reduction of the possible number of I/O modules, if:

- the type DO910 is used to power valves which support less than 1500 Ω input impedance
- types AO920 (or AI920 / AI921) are to be used exclusively.

In these cases, the user must ensure that the total power loss of all Ex modules is less than 45 Watt. (For non-Ex modules / type N a total power loss of less than 60 Watt must be observed).

When using redundant termination units (e.g. TU921), a redundant slot can be left free for the power supply unit if required. The power supply units are designed to power the entire S900 station.

Range of applications

The S900 Remote I/O System is tailored to applications in the field of process engineering. It provides a variety of functions which make the system robust, fault-tolerant and easy to diagnose. The main features of the system are its compact design, the redundant bus architecture, and the direct access to the configuration data of the connected HART[®]-compatible instruments via the fieldbus network.

The S900 Remote I/O System is the economic extension of your sensors and actors which can be directly contacted via the standardized fieldbus protocol. Due to the FDT/DTM technology both simple digital field instruments or temperature sensors and the wellproven basis of the intelligent HART[®] instruments can be integrated easily into the fieldbus system.

As a result, the S900 Remote I/O System provides a considerable cost-saving potential for all applications in the field of process engineering.

General Data

Power supply

Material	Aluminium anodized
Colour	RAL 9002 + black
External dimensions (W x H x D)	47 x 129 x 117 mm
Weight	approx. 1.5 kg

I/O modules and communication interface

Material	PC
Fire protection class	V2, UL 94 (DIN IEC 707)
Colour (light grey)	RAL 9002
External dimensions (W x H x D)	20 x 104 x 104 mm
Weight	approx. 0.15 kg
Test voltage (fieldbus, PS, I/O)	1500 V
Test voltage (fieldbus -> I/O)	500 V (intrinsically safe Profibus)
Test voltage (I/O -> I/O)	500 V (with el. isolation)

Termination unit

Material	Aluminium chromatised
Colour	Aluminium + RAL 9002
External dimensions (W x H x D)	498 x 274 x 147 mm
Weight	approx. 3 kg

Mounting

Zone1/Zone 2 (modules B/S only)

Operating temperature	
horizontal mounting	-20 °C...60 °C
vertical mounting	not allowed
Storage temperature	-40 °C...85 °C

Standards

Transport / shock	15 g (IEC 68-2-27)
Function / Vibration	2 g (IEC 68-2-6)
Reference conditions	IEC 60770
EMC	EN 61326
Humidity	IEC 60654, T 1-4
Relative humidity	< 85% (annual average)
Condensation	short duration, commissioning or temperature transient
Corrosive gases	ANSI/ISA S71.04 G3 Harsh Group A DIN EN 60068-2-60 Method 4

System Architecture

I/O modules per station	16 (on Termination Unit)
No. of channels	2, 4 and 8 channel
S900 stations for Zone 1 (IS fieldbus via IS isolating repeater)	
mounting options	safe area, Zone 2, Zone 1
stations / isolating repeater	max. 10 stations type S
S900 stations für Zone 2 (IS fieldbus via IS isolating repeater)	
mounting options	safe area, Zone 2
stations / isolating repeater	max. 10 stations type B
S900 stations for safe area (standard fieldbus)	
mounting options	safe area
S900 stations per bus line	PROFIBUS non-Ex standard
Bus length (copper)	200 m (1.5 MBaud) 400 m (0.5 MBaud)
Bus length (fibre optic)	(see instruction manual)

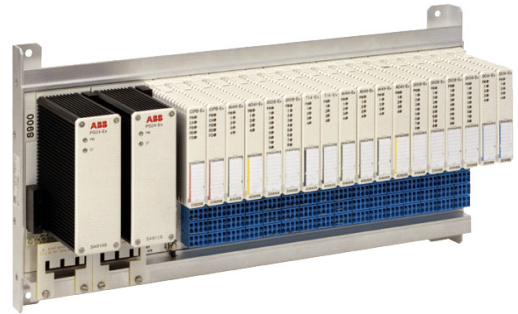

Device variants for

safe area mounting	Type N
Zone 2 mounting	Type B
Zone 1 mounting	Type S

Attention:

Do not mix Type N, B, S components!

Examples for applications

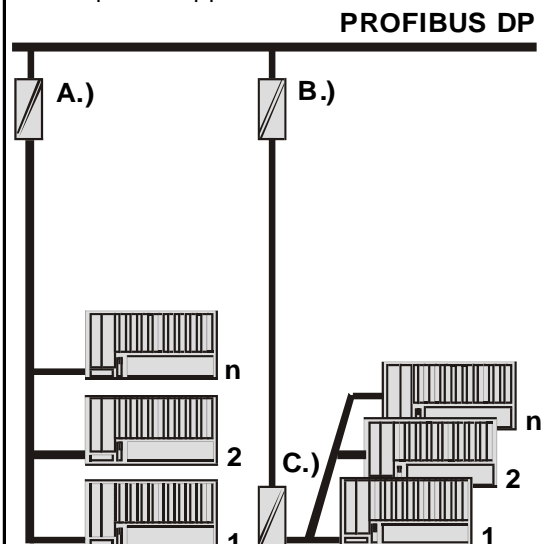

- A.) isolating repeater (e.g. BI912S / BI913S)
- B.) fibre optic converter (e.g. BI924S)
- C.) fibre optic converter Zone 1 (e.g. BI933S)

Conditions

All specifications are valid only if the products are stored correctly and used as intended.

Storage of the equipment into original packing only!

- Stainless steel field housing for extended termination unit
- Prepared for wall mounting
- Optional isolated shielding bar or terminals
- Mounting in Zone 1 or Zone 2

Technical Data

Explosion protection (type ...S) PTB 02 ATEX 1133
 Type of protection II 2(1)G EEx edm ia/ib [ia] IIC T4

General Data FH660S

External dimensions (W x H x D) 600 x 600 x 300 mm
 Protection degree IP 66 (EN 60529)
 Drain plug/breather M25, IP 56
 Door hinges left hand side
 Material M6, stainless steel 1.4301
 Cable gland Brass (chromium-plated)
 - for central power 6 x M20 / 2 x M32
 cable diameter 8.5...13 mm / 17.5...25 mm
 - for field signals and fieldbus 100 x M16
 cable diameter 6...11 mm
 External earth M6, stainless steel 1.4301
 Weight
 - without S900 Process I/O approx. 24 kg
 - fully equipped approx. 33 kg

General Data FH680S

External dimensions (W x H x D) 600 x 800 x 300 mm
 Protection degree IP 66 (EN 60529)
 Drain plug/breather M25, IP 56
 Door hinges left hand side
 Material M6, stainless steel 1.4301
 Cable gland Brass (chromium-plated)
 - for central power 6 x M20 / 2 x M32
 cable diameter 8.5...13 mm / 17.5...25 mm
 - for field signals and fieldbus 100 x M16
 cable diameter 6...11 mm
 External earth M6, stainless steel 1.4301
 Weight
 - without S900 Process I/O approx. 31 kg
 - fully equipped approx. 40 kg

Note:

Other field housings on request.

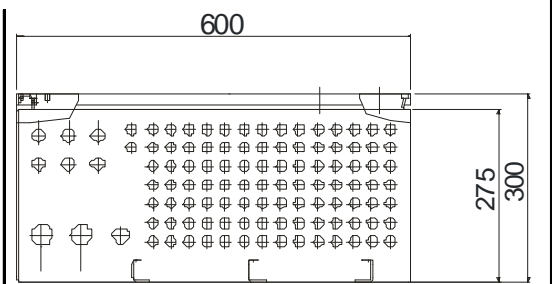

Bottom view FH660S

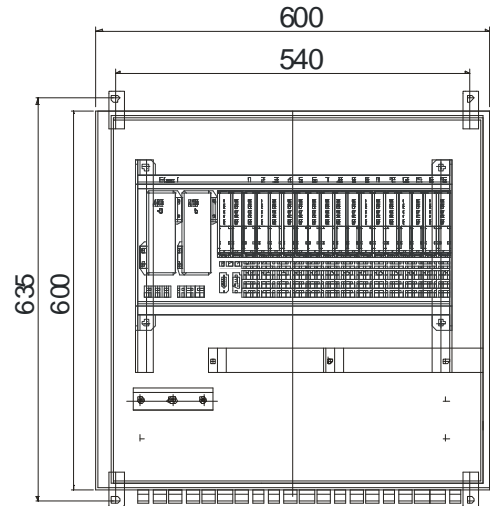

Front (inside) view FH660S

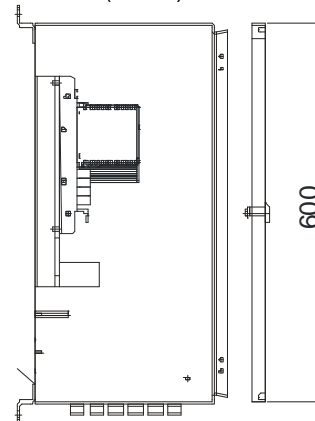

Side view FH660S

Order No.	FH660S	3KDE15804L
	FH680S	3KDE15811L

- Field housing for power supply and communication interface
- Mounting of max. 4 I/O modules
- Preselection of fieldbus address (0 ... 99)
- Separation of function level and wiring level
- Mounting in Zone 1 or Zone 2

Technical Data

I/O modules and communication interface

Material	PC
Fire protection class	V2, UL 94 (DIN IEC 707)
Colour (light grey)	RAL 9002
External dimensions (W x H x D)	20 x 104 x 104 mm
Weight	approx. 0.15 kg
Test voltage (fieldbus, PS, I/O)	1500 V
Test voltage (fieldbus -> I/O)	500 V (intrinsically safe Profibus)
Test voltage (I/O -> I/O)	500 V (with el. isolation)

Mounting Zone1/Zone 2 (modules S/B only)

Operating temperature	
horizontal mounting	-20 °C...60 °C Observe equipping !
vertical mounting	not allowed
Storage temperature	-40 °C...85 °C

Fieldbus connection PROFIBUS DP

Preselection of bus address	0 ... 99 (rotary switch)
Bus termination	(see manual)

Standards

Transport / shock	15 g (IEC 68-2-27)
Function / Vibration	2 g (IEC 68-2-6)
Reference conditions	IEC 60770
EMC	EN 61326
Humidity	IEC 60654, T 1-4
Relative humidity	< 85% (annual average)
Condensation	short duration, commissioning
Corrosive gases	ANSI/ISA S71.04 G3 Harsh Group A DIN EN 60068-2-60 Method 4

System Architecture

I/O modules per station	max. 4
No. of channels	2, 4, 6 and 8 channel
Bus length (copper)	200 / 400 m (1.5 / 0.5 Mbaud)

CB220 in Zone 1 (type S)
 mounting possibilities safe area, Zone 2, Zone 1
 stations / isolating repeater max. 10 stations type S

CB220 in Zone 2 (type B)
 mounting possibilities safe area, Zone 2
 stations / isolating repeater max. 10 stations type B

CB220 in safe area (type N)
 mounting possibilities safe area
 stations per bus line PROFIBUS non-Ex standard

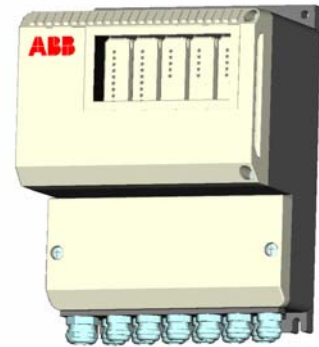

Device variants for

safe area mounting	Type N
Zone 2 mounting	Type B
Zone 1 mounting	Type S

Attention:
Do not mix Type N, B, S components!

Examples for applications

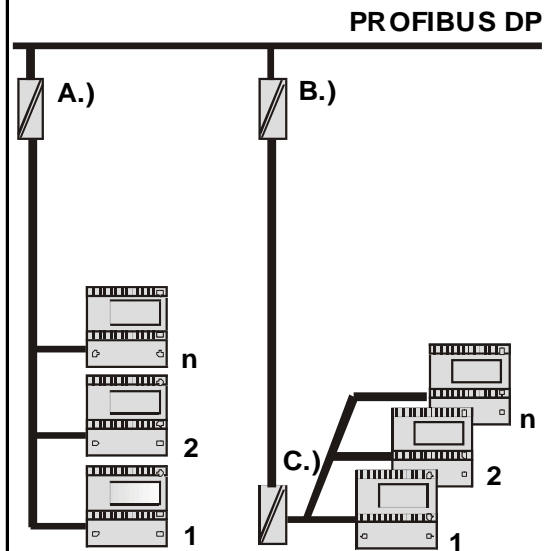

- A.) isolating repeater (e.g. BI912S / BI913S)
- B.) fibre optic converter (e.g. BI924S)
- C.) fibre optic converter Zone 1 (e.g. BI933S)

Conditions

All specifications are valid only if the products are stored correctly and used as intended.

Storage of the equipment into original packing only!

General Data

Protection class	IP66 (EN60529)
Door hinges	left hand side
Material	Aluminium
Colour (light grey)	RAL 9002
External dimensions (W x H x D)	208 x 278 x 153 mm
Weight	
- only CB220	approx. 3.8 kg
- fully equipped	approx. 5.8 kg
Cable gland	
- for central power	1 x M20
cable diameter	8...12 mm
- for field signals and fieldbus	12 x M16
cable diameter	6...9 mm
External earth	M6, stainless steel 1.4301
Fastening drillings	4 x 6.8 mm diameter

Terminals

System power terminals	EEx e (black)
Wire CSA	0,5 ... 2,5 mm ²
Connection	screw terminals
I/O and fieldbus terminals (type N)	black
I/O and fieldbus terminals (type B)	EEx i (blue)
I/O and fieldbus terminals (type S)	EEx i (blue)
Wire CSA	0,08 ... 2,5 mm ²
Connection	Spring loaded

Power

Supply voltage	24 V DC (19.2...32 V)
Max. current consumption	see power supply
Power consumption	see power supply

Explosion protection (type ...S) PTB 04 ATEX 2054
II 2(1)G EEx em ib/ia IIC T4

Explosion protection (type ...B) PTB 04 ATEX 2093
II (1 / 2)G [EEx ib/ia] IIB/IIC
PTB 04 ATEX 2094
II 3 G EEx nA II T4

Front view drawing

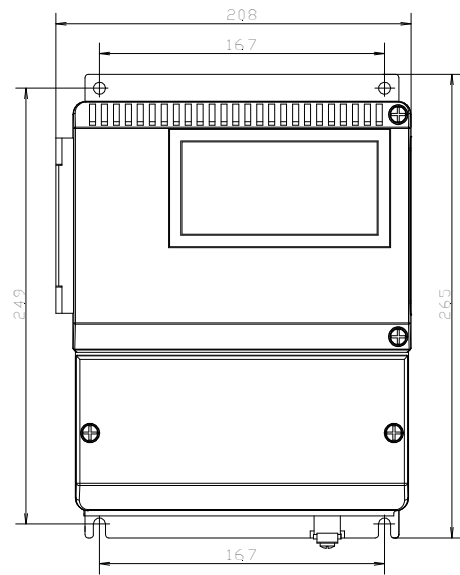

Side view drawing

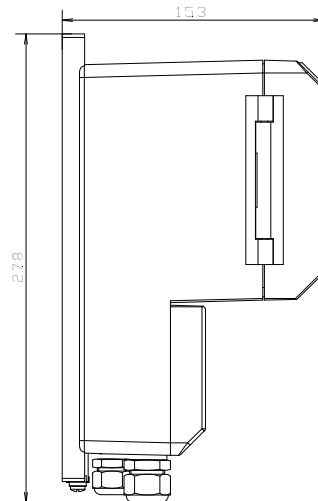

Order No.	CB220S	3KDE175611L2210
	CB220B	3KDE175612L2210
	CB220N	3KDE175613L2210

- Termination unit for up to 16 I/O modules
- Prepared for redundant system power and communication
- Up to 4 terminals per channel
- Preselection of fieldbus address
- Prepared for certified field housing
- Mounting in Zone 1 or Zone 2 possible

Technical Data

Field Terminals

Rated supply voltage (PS)	depending on power supply
System power terminals	screw terminals
Wire CSA	0,5 ... 2,5 mm ²
Fieldbus plug connector	SUB D, 9 pins
Preselection of bus address	0 ... 126 (rotary switch)
I/O Terminals (type TU921N)	black
I/O Terminals (type TU921B)	EEx i (blue)
I/O Terminals (type TU921S)	EEx i (blue)
Wire CSA	0,08 ... 2,5 mm ²
Connection	Spring loaded

Explosion protection (type ...S) PTB 00 ATEX 2156 U
II 2(1) G EEx e ib [ia] IIC

Explosion protection (type ...B) PTB 03 ATEX 2028
II (2) G [EEx ib] IIB/IIC
PTB 03 ATEX 2029
II 3 G EEx nA II T4

General Data

Protection class	
I/O Terminals	IP 20
System power terminals	IP 30
Electrical safety	EN 61010
Explosion protection	EN 50020, EN 50019, EN 50021
Mounting in a junction box	Zone 1 (S), Zone 2 (B)
Required protection class	IP 54 or better
External dimensions (W x H x D)	498 x 274 x 147 mm
Weight	3 kg

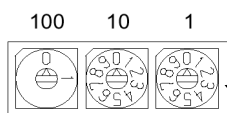

Setting of
PROFIBUS address

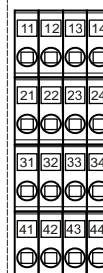
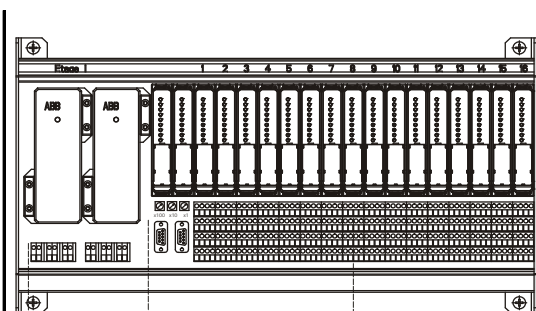

I/O Terminals

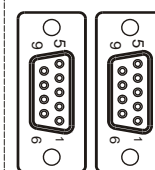

PROFIBUS
3 B-Line
5 GND
6 +5V
D-SUP

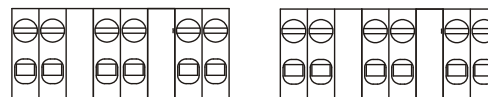

L DC+ 1.1 1.2 N DC- 1.3 1.4 PE 1.5 1.6 L DC+ 2.1 2.2 N DC- 2.3 2.4 PE 2.5 2.6

System power terminals

Order No.	TU921S	3KDE175111L9210
	TU921B	3KDE175112L9210
	TU921N	3KDE175113L9210

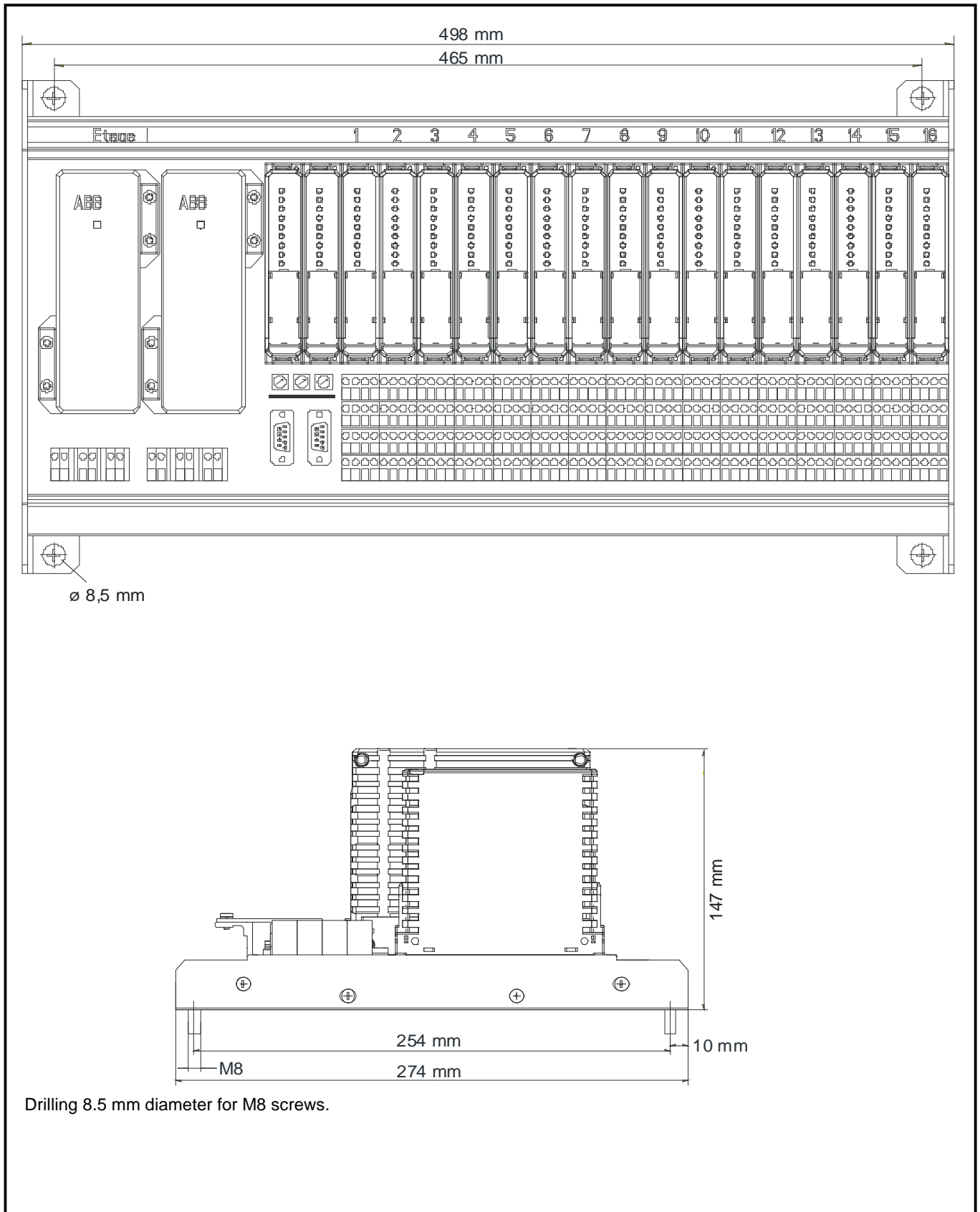

- Powering of communication interfaces and I/O modules
- Hot swap capability
- Redundant powering
- Alarm in case of power failure (with redundancy)

for TU921N

Technical Data

Input

Power supply (PS)	24 V DC (19.2...32 V DC)
Max. current consumption	< 2.95 A / 24 V; < 3.65 A / 19.2 V
Power consumption	≤ 70 Watt, Ta ≤ 60 °C

Output

Available power for modules	≤ 60 Watt, Ta ≤ 60 °C ≤ 45 Watt, Ta ≤ 70 °C
Number of powered modules (Ta ≤ 60 °C)	16 I/O modules + 2 x CI920N * < 16 I/O modules + 2 x CI920N ** e.g. 9 x DO910N + 2 x CI920N ***

- * for any I/O module with power loss < 3.4 W
- ** for I/O modules with power loss > 3.4 W
- *** DO910N with power loss > 2.2 W (for valves <1500 Ohm)

Diagnosis

Module power on	LED green
-----------------	-----------

Test voltage

Power supply	
- for module supply	1500 V AC
- for Exi current circuits	1500 V AC
- for PA/PE	500 V AC
EEx i - current circuits	
- for module supply	500 V AC

General Data

External dimensions (W x H x D)	47 x 129 x 117 mm
Weight	approx. 1.4 kg

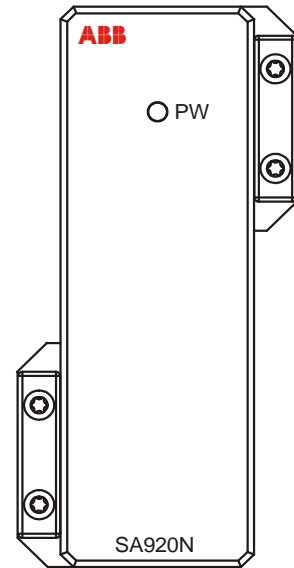

Do not mix SA910N and SA920N for redundancy on TU921N!

Observe Release Note 3BDD010401!

Order No.		
	SA920N	3BDH000600R1



Observe Installation Guide
3BDD010421_CIO_S900_Install_S-N-System_SA920x

- Powering of communication interfaces and I/O modules
- Hot swap capability in Zone 2
- Redundant powering
- Alarm in case of power failure (with redundancy)
- Switching On by tighten the 4 switch-on interlock screws

for TU921B

Technical Data

Input

Power supply (PS)	24 V DC (19.2...32 V DC)
Max. current consumption	< 2.71 A / 24 V; < 3.39 A / 19.2 V
Power consumption	≤ 65 Watt, Ta ≤ 60 °C

Output

Available power for modules	≤ 55 Watt, Ta ≤ 60 °C ≤ 45 Watt, Ta ≤ 70 °C
Number of powered modules (Ta ≤ 60 °C)	16 I/O modules + 2 x CI920B * < 16 I/O modules + 2 x CI920B ** e.g. 7 x DO910B + 2 x CI920B *** e.g. 12 x AO920B + 2 x CI920B

- * for any I/O module with power loss < 2.5 W
- ** for I/O modules with power loss > 2.5 W
- *** DO910S with power loss > 2.2 W (for valves <1500 Ohm)

Explosion protection (type ...B)	PTB 03 ATEX 2028
Type of protection	II (2) G [Ex ib] IIB/IIC
	PTB 03 ATEX 2029
	II 3 G Ex nA nC II T4

Diagnosis

Module power on	LED green
-----------------	-----------

Test voltage

Power supply	
- for module supply	1500 V AC
- for Exi current circuits	1500 V AC
- for PA/PE	500 V AC
EEx i - current circuits	
- for module supply	500 V AC

General Data

External dimensions (W x H x D)	47 x 129 x 117 mm
Weight	approx. 1.4 kg

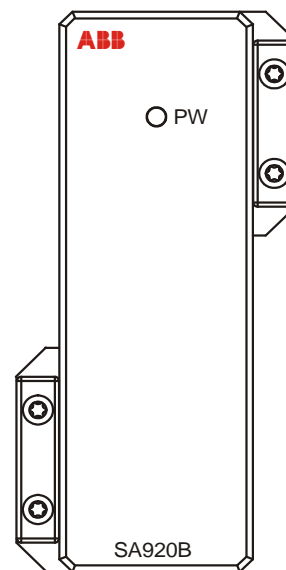

Do not mix SA910B and SA920B for redundancy on TU921B!

Observe Release Note 3BDD010401!

Order No.	SA920B	3BDH000601R1



Observe Installation Guide 3BDD010432_CIO_S900_Install_B-System_SA920B

- Powering of communication interfaces and I/O modules
- Hot swap capability in Zone 1
- Redundant powering
- Alarm in case of power failure (with redundancy)
- Switching On by tighten the 4 switch-on interlock screws

for TU921S

Technical Data

Input

Power supply (PS)	24 V DC (19.2...32 V DC)
Max. current consumption	< 2.71 A / 24 V; < 3.39 A / 19.2 V
Power consumption	≤ 65 Watt, Ta ≤ 60 °C

Output

Available power for modules	≤ 55 Watt, Ta ≤ 60 °C ≤ 45 Watt, Ta ≤ 70 °C
Number of powered modules (Ta ≤ 60 °C)	16 I/O modules + 2 x CI920S * < 16 I/O modules + 2 x CI920S ** e.g. 7 x DO910S + 2 x CI920S *** e.g. 12 x AO920S + 2 x CI920S

- * for any I/O module with power loss < 2.5 W
- ** for I/O modules with power loss > 2.5 W
- *** DO910S with power loss > 2.2 W (for valves <1500 Ohm)

Explosion protection (type ...S) PTB 07 ATEX 2020
Type of protection II 2 G Ex de [ib] IIC T4

Diagnosis

Module power on	LED green
-----------------	-----------

Test voltage

Power supply	
- for module supply	1500 V AC
- for Exi current circuits	1500 V AC
- for PA/PE	500 V AC
EEx i - current circuits	
- for module supply	500 V AC

General Data

External dimensions (W x H x D)	47 x 129 x 117 mm
Weight	approx. 1.4 kg

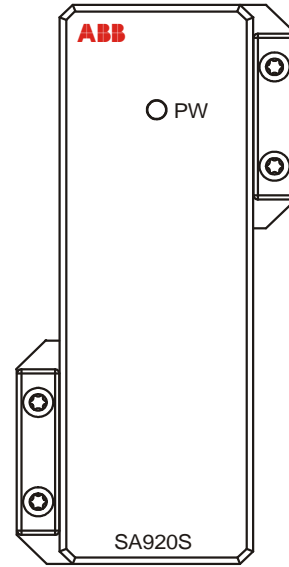

Do not mix SA910S and SA920S for redundancy on TU921S!

Observe Release Note 3BDD010401!

Order No.	SA920S	3BDH000602R1



Observe Installation Guide
3BDD010421_CIO_S900_Install_S-N-System_SA920x

- **Powering of communication interfaces and I/O modules**
- **Hot swap capability**
- **Redundant powering**
- **Alarm in case of power failure (with redundancy)**

for TU921N

Technical Data

Input

Power supply (PS)	24 V DC (19.2...32 V)
Max. current consumption	< 2.7 A / 24 V; < 3.4 A / 19.2 V
Power consumption	< 65 Watt

Output

Available power for modules	< 60 Watt
Number of powered modules	16 I/O modules + 2 x CI920N * < 16 I/O modules + 2 x CI920N ** e.g. 9 x DO910N + 2 x CI920N ***

- * for any I/O module with power loss < 3.4 W
- ** for I/O modules with power loss > 3.4 W
- *** DO910N with power loss > 2.2 W (for valves <1500 Ohm)

Diagnosis

System / Module power on	LED green / green
--------------------------	-------------------

Test voltage

Power supply	
- for module supply	1500 V AC
- for Exi current circuits	1500 V AC
- for PA/PE	500 V AC
EEx i - current circuits	
- for module supply	500 V AC

General Data

External dimensions (W x H x D)	45 x 135 x 105 mm
Weight	approx. 0.8 kg

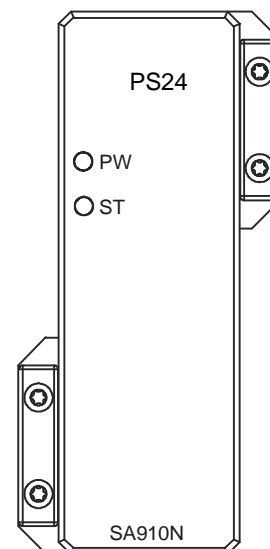

For redundant use in existing installations with power supplies of type SA910N only!

Do not mix SA910N and SA920N for redundancy on TU921N!

Observe Release Note 3BDD010401!

Order No.		
	SA910N	3KDE175133L9100

Observe the order of installation for SA910N:

1. Connect supply lines to termination unit
2. Plug the SA910N into the termination unit
3. Switch on primary power supply

Do not connect supply lines under power to the termination unit when an enabled SA910N module is plugged into the termination unit.

For redundancy operation of SA910N, use independent primary power supplies with a peak power (10 ms) > 210 W only !
For single operation of SA910N, only primary power supplies with a peak power (10 ms) > 70 W only !

- Powering of communication interfaces and I/O modules
- Hot swap capability in Zone 2
- Redundant powering
- Alarm in case of power failure (with redundancy)
- Switching On by tighten the 4 switch-on interlock screws

for TU921B

Technical Data

Input

Power supply (PS)	24 V DC (19.2...32 V)
Max. current consumption	< 2.1 A / 24 V; < 2.6 A / 19.2 V
Power consumption	< 50 Watt

Output

Available power for modules	< 45 Watt
Number of powered modules	16 I/O modules + 2 x CI920B * < 16 I/O modules + 2 x CI920B ** e.g. 7 x DO910B + 2 x CI920B *** e.g. 12 x AO920B + 2 x CI920B

- * for any I/O module with power loss < 2.5 W
- ** for I/O modules with power loss > 2.5 W
- *** DO910S with power loss > 2.2 W (for valves <1500 Ohm)

Explosion protection (type ...B)	PTB 03 ATEX 2028
Type of protection	II (2) G [Ex ib] IIB/IIC
	PTB 03 ATEX 2029
	II 3 G EEx nA nC II T4

Diagnosis

System / Module power on	LED green / green
--------------------------	-------------------

Test voltage

Power supply	
- for module supply	1500 V AC
- for Exi current circuits	1500 V AC
- for PA/PE	500 V AC
EEx i - current circuits	
- for module supply	500 V AC

General Data

External dimensions (W x H x D)	45 x 135 x 105 mm
Weight	approx. 1.2 kg

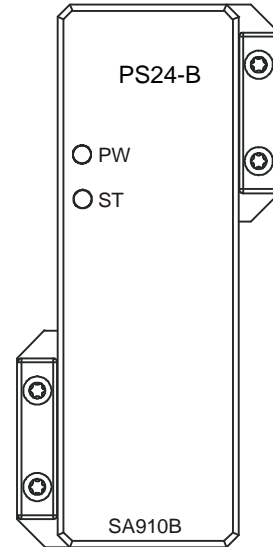

For redundant use in existing installations with power supplies of type SA910B only!

Do not mix SA910B and SA920B for redundancy on TU921B!

Observe Release Note 3BDD010401!

Order No.	SA910B	3KDE175132L9100

Observe the order of installation for SA910B:

1. Connect supply lines to termination unit.
2. Plug the SA910B into the termination unit.
3. Switch on primary power supply.
4. Tighten the switch-on interlock screws, SA910B starts up.

Do not connect supply lines under power to the termination unit when the SA910B is plugged into the termination unit and is enabled (i.e. the switch-on interlock screws are tightened).

For redundancy operation of SA910B, use only independent primary power supplies with a peak power (10 ms) > 170 W !
For single operation of SA910B, use primary power supplies with a peak power (10 ms) > 60 W only !

- **Powering of communication interfaces and I/O modules**
 - **Hot swap capability in Zone 1**
 - **Redundant powering**
 - **Alarm in case of power failure (with redundancy)**
 - **Switching On by tighten the 4 switch-on interlock screws**
 - **Connect power conditioner BP901S between primary supply and termination unit**
- for TU921S**

Technical Data

Input

Power supply (PS)	24 V DC (19.2...32 V)
Max. current consumption	< 2.1 A / 24 V; < 2.6 A / 19.2 V
Power consumption	< 50 Watt

Output

Available power for modules	< 45 Watt
Number of powered modules	16 I/O modules + 2 x CI920S * < 16 I/O modules + 2 x CI920S ** e.g. 7 x DO910S + 2 x CI920S *** e.g. 12 x AO920S + 2 x CI920S

- * for any I/O module with power loss < 2.5 W
- ** for I/O modules with power loss > 2.5 W
- *** DO910S with power loss > 2.2 W (for valves <1500 Ohm)

Explosion protection (type ...S) PTB 00 ATEX 2199
Type of protection II 2 G EEx m [ib] e IIC T4

Diagnosis

System / Module power on	LED green / green
--------------------------	-------------------

Test voltage

Power supply	
- for module supply	1500 V AC
- for Exi current circuits	1500 V AC
- for PA/PE	500 V AC
EEx i - current circuits	
- for module supply	500 V AC

General Data

External dimensions (W x H x D)	45 x 135 x 105 mm
Weight	approx. 1.2 kg

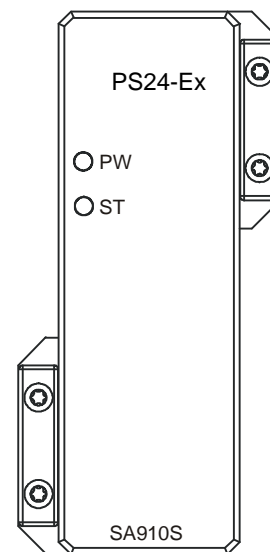

For redundant use in existing installations with power supplies of type SA910S only!

Do not mix SA910S and SA920S for redundancy on TU921S!

Observe Release Note 3BDD010401!

Order No.	SA910S	3KDE175131L9100

Observe the order of installation for SA910S:

1. Connect supply lines to termination unit.
2. Plug the SA910S into the termination unit.
3. Switch on primary power supply.
4. Tighten the switch-on interlock screws, SA910S starts up.

Do not connect supply lines under power to the termination unit when the SA910S is plugged into the termination unit and is enabled (i.e. the switch-on interlock screws are tightened).

For redundancy operation of SA910S, use independent primary power supplies with a peak power (10 ms) > 170 W only !
For single operation of SA910S, use primary circuits with a peak power (10 ms) > 60 W only !

- Powering of communication interfaces and I/O modules
- Hot swap capability

for CB220N

Technical Data

Input

Power supply (PS)	24 V DC (19.2...32 V)
Max. current consumption	< 1.25 A / 24 V; < 1.56 A / 19.2 V
Power consumption	< 30 Watt

Output

Available power for modules	< 27 Watt
-----------------------------	-----------

Diagnosis

System / Module power on	LED green / green
--------------------------	-------------------

Test voltage

Power supply	
- for module supply	1500 V AC
- for Exi current circuits	1500 V AC
- for PA/PE	500 V AC
EEx i - current circuits	
- for module supply	500 V AC

General Data

External dimensions (W x H x D)	45 x 135 x 105 mm
Weight	approx. 0.8 kg

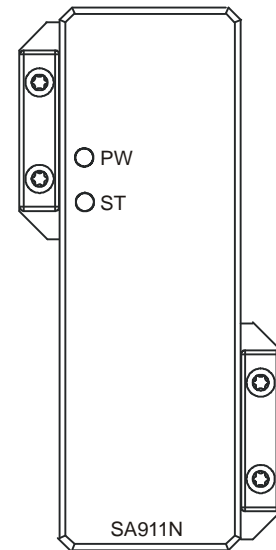

Order No.		
	SA911N	3KDE175613L9110

Observe the order of installation for SA911N:

1. Connect supply lines to CB220N.
2. Plug the SA911N into the CB220N.
3. Switch on primary power supply

Do not connect supply lines under power to the CB220N when an enabled SA911N is plugged into the CB220N.

For single operation of SA911N, use primary power supplies with a peak power (10 ms) > 50 W only !

- Powering of communication interfaces and I/O modules
- Hot swap capability in Zone 2

for CB220B

Technical Data

Input

Power supply (PS)	24 V DC (19.2...32 V)
Max. current consumption	< 1.25 A / 24 V; < 1.56 A / 19.2 V
Power consumption	< 30 Watt

Output

Available power for modules	< 27 Watt
-----------------------------	-----------

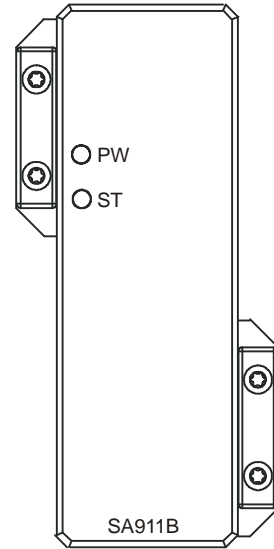

Explosion protection (type ...B)	PTB 04 ATEX 2093
Type of protection	II (2) G [Ex ib] IIB/IIC
	PTB 04 ATEX 2094
	II 3 G EEx nA II T4

Diagnosis

System / Module power on	LED green / green
--------------------------	-------------------

Test voltage

Power supply	
- for module supply	1500 V AC
- for Exi current circuits	1500 V AC
- for PA/PE	500 V AC
EEx i - current circuits	
- for module supply	500 V AC

General Data

External dimensions (W x H x D)	45 x 135 x 105 mm
Weight	approx. 1.2 kg

Order No.		
	SA911B	3KDE175612L9110

Observe the order of installation for SA911B:

1. Connect supply lines to CB220.
2. Plug the SA911B into the CB220B.
3. Switch on primary power supply.
4. Tighten the switch-on interlock screws, SA911B starts up.

Do not connect supply lines under power to the termination unit when the SA911B is plugged into the termination unit and is enabled (i.e. the switch-on interlock screws are tightened).

For single operation of SA911B, use primary power supplies with a peak power (10 ms) > 50 W only !

- Powering of communication interfaces and I/O modules
- Hot swap capability in Zone 1

for CB220S

Technical Data

Input

Power supply (PS)	24 V DC (19.2...32 V)
Max. current consumption	< 1.25 A / 24 V; < 1.56 A / 19.2 V
Power consumption	< 30 Watt

Output

Available power for modules	< 27 Watt
-----------------------------	-----------

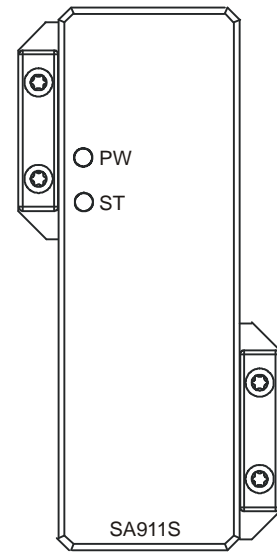

Explosion protection (type ...S) PTB 04 ATEX 2054
 Type of protection II2G EEx em[ib] IIC T4

Diagnosis

System / Module power on	LED green / green
--------------------------	-------------------

Test voltage

Power supply	
- for module supply	1500 V AC
- for Exi current circuits	1500 V AC
- for PA/PE	500 V AC
EEx i - current circuits	
- for module supply	500 V AC

General Data

External dimensions (W x H x D)	45 x 135 x 105 mm
Weight	approx. 1.2 kg

Order No.	SA911S	3KDE175611L9110

Observe the order of installation for SA911S:

1. Connect supply lines to CB220.
2. Plug the SA911S into the CB220S.
3. Switch on primary power supply.
4. Tighten the switch-on interlock screws, SA911S starts up.

Do not connect supply lines under power to the termination unit when the SA911S is plugged into the termination unit and is enabled (i.e. the switch-on interlock screws are tightened).

For single operation of SA911S, use primary power supplies with a peak power (10 ms) > 50 W only !

- Power supply filter with increased safety
- Zone 1 mounting inside approved field housings
- Ready for mounting to 24 V DC power supplies
- Connect power conditioner between primary supply and backplane

Technical Data

Nominal voltage $U_N = 24 \text{ V DC}$
 Voltage range 19.2...33 V DC
 Nominal current $I_N = 4 \text{ A}$
 Integrated capacitance $C = 470 \mu\text{F}$

Explosion protection (type ...S) PTB 97 ATEX 1068 U
 Type of protection II 2 G EEx de IIC I M 2 EEx de I T4

General Data

Mounting Zone 1
 Mounting type on top hat rail NS35 according to EN 50022
 Protection class IP 20
 Mounting orientation any
 Storage temperature $-40 \dots +60 \text{ }^\circ\text{C}$
 Operating temperature $-20 \dots +60 \text{ }^\circ\text{C}$
 Relative humidity $< 85 \%$
 Material thermoplastic resin
 External dimensions (W x H x D) 30 mm x 91 mm x 94 mm
 Weight approx. 0.27 kg

Attention:

The power supply filter only is needed for use with power supply SA910S!

The power supply filter is not needed for installing CB220S, CB220B and CB220N.

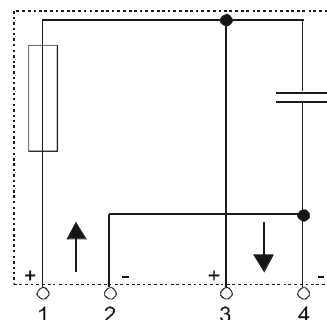

Terminal assignment

Example of application

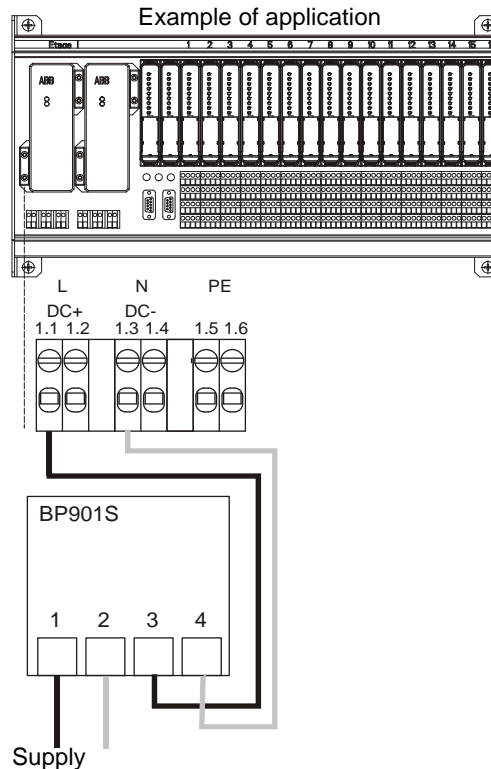

Order No.	BP901S	3KDE175831L9010

- Fieldbus protocol PROFIBUS-DP V1 (EN 50170)
- Coupling of the internal CAN bus to external PROFIBUS
- HART protocol on PROFIBUS-DP V1
- Line or media redundancy via two coupling modules
- Electrical isolation between field bus, power
- Diagnosis, configuration and parameterisation via PROFIBUS

Technical Data

Internal bus

Internal bus protocol	CAN Open
Cycle time for digital I/Os	< 5 ms
Cycle time for analog I/Os	< 20 ms

Fieldbus

	PROFIBUS-DP V1, C1+C2 (EN 50170), RS485 intrinsically safe (CI920S) redundancy
DP baud rate	max. 1.5 Mbaud Hot Configuration in Run (HCIR)

Explosion protection (type ...S) PTB 00 ATEX 2201
II 2 G SYST EEx ib IIC T4

Explosion protection (type ...B) PTB 03 ATEX 2028
II (2) G [EEx ib] IIB/IIC
PTB 03 ATEX 2029
II 3 G EEx nA II T4

Diagnosis

System / Module power on	LED green / red
PROFIBUS communication	LED yellow / red
Internal communication	LED yellow / red
Active status	LED yellow
Configuration error	LED red

Via fieldbus

- Station diagnosis
- Redundancy diagnosis
- I/O module diagnosis
- Channel diagnosis

Configuration and Parameterization

DTM	FDT 1.2 (observe release notes)
GSD	

General Data

Power consumption	approx. 2.5 W
-------------------	---------------

Attention:

Redundancy works only with 2 CI920x with the same firmware observe release notes

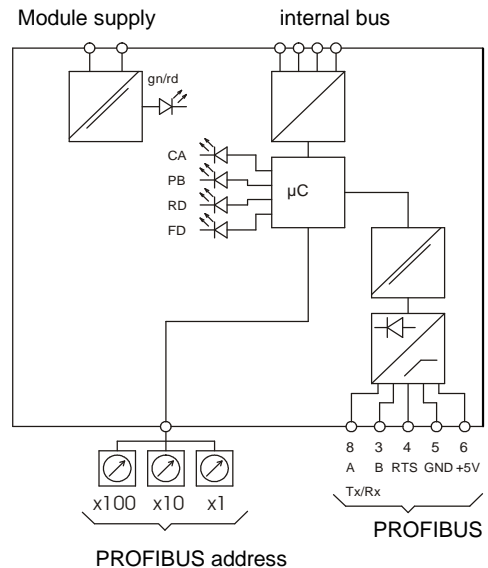
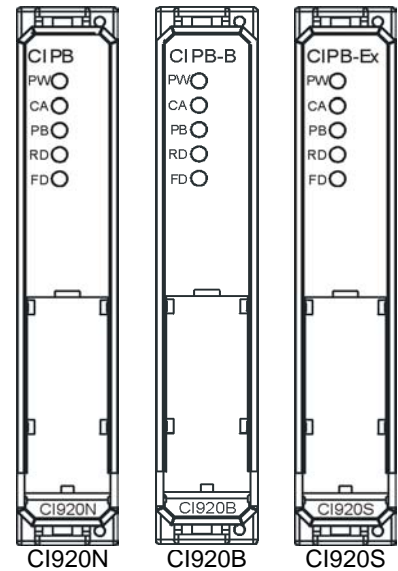

Setting has to be done on termination unit

At TU921 below the bus couplers
At CB220 on the right next to the bus coupler

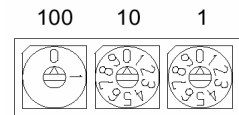

Order No.	CI920S	3BDS014111
Firmware	CI920B	3BDS014112
V.1.5.x	CI920N	3BDS014113
Order No.	CI920S	3KDE175121L9200
Firmware	CI920B	3KDE175122L9200
V.1.4.x	CI920N	3KDE175123L9200

- Input for dry contacts or proximity switches (NAMUR)
- Output for low power intrinsically safe valves
- Short and break detection
- Electrical isolation between input / bus and input / power
- Common return for all inputs / outputs
- Configurable as a mixture of inputs and outputs
- 8 I/O channel, EEx ia II C

Technical Data

Input

No-load voltage	8 V DC
Short-circuit current	4 mA...5 mA
Switching point in range	1.4...1.8 mA
Switching hysteresis	0.2 mA
Switching frequency	< 100 Hz
Short-circuit detection	< 300...350 ohms
Line-break detection	< 0.1...0.2 mA

Explosion protection (type ...S) PTB 00 ATEX 2180
II 2(1) G EEx ib [ia] IIC T4

Explosion protection (type ...B) PTB 03 ATEX 2078
II (1) G [EEx ia] IIB/IIC
PTB 03 ATEX 2079
II 3 G EEx nA II T4

Input or output

Max. short-circuit current	$I_o = 44 \text{ mA}$
Max. voltage	$U_o = 9,6 \text{ V}$
Max. power	$P_o = 106 \text{ mW}$
External inductance	$L_o = 1 \text{ mH}$
External capacitance	$C_o = 1100 \text{ nF}$

Output

No-load voltage	approx. 8 V DC
Effective current	< 4 mA
Internal resistance	320 ohms
Switching frequency	< 100 Hz
Short-circuit detection	300...350 ohms
Line-break detection	0.1... 0.2 mA

Diagnosis

System / Module power on	LED green / red
Open (off)/ closed (on)	LED 1...8, off / yellow
Line break or short circuit	LED 1...8, red

Via fieldbus

Break, short	channelwise
Simulation	channelwise
Via fieldbus	for each I/O module

Characteristics at rated conditions

De-bounce filter, software on/off	2...100 ms
Power consumption	< 1.1 W

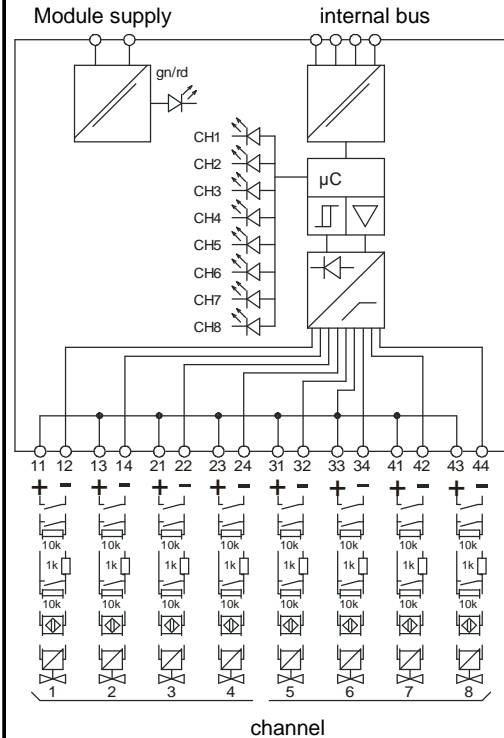
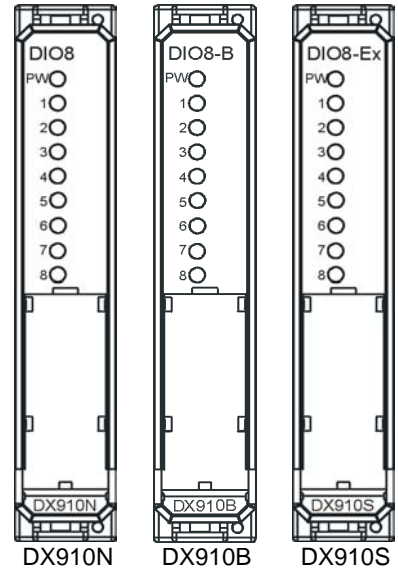

Inputs for:
dry contacts, NAMUR proximity switches
Output for valves from e.g.:
Samson (all standard valves with 6 V coil)

Order No.	DX910S	3KDE175311L9100
	DX910B	3KDE175312L9100
	DX910N	3KDE175313L9100

- Output for intrinsically safe valves or alarms
- Integrated driving power
- Short and break detection
- Electrical isolation between output / bus and output / power
- Electrical isolation channel to channel
- 4 channels, EEx ia II C

Technical Data

Output	high voltage (low voltage)
Supply voltage and current	21 V / 8 mA (Curve A) 18 V / 20 mA (Curve A) 15 V / 30 mA (Curve B) 12 V / 40 mA (Curve B)
No-load voltage	24 V DC (16 V DC)
Internal resistance	300 ohms
Switching frequency	< 100 Hz
Line-break detection	< 0.2...1.2 mA

Explosion protection (type ...S) PTB 01 ATEX 2048
II 2(1) G EEx ib [ia] IIC T4

Explosion protection (type ...B) PTB 03 ATEX 2078
II (1) G [EEx ia] IIB/IIC
PTB 03 ATEX 2079
II 3 G EEx nA II T4

Max. short-circuit current	$I_o = 100 \text{ mA}$
Max. voltage	$U_o = 27 \text{ V (18,9 V)}$
Max. power	$P_o = 675 \text{ mW}$
External inductance	$L_o = 0,5 \text{ mH}$
External capacitance	$C_o = 46 \text{ nF}$

Diagnosis

System / Module power on	LED green / red
Output on	LED 1...4, yellow
Line break or short circuit	LED 1...4, red

Via fieldbus

Break, short	channelwise
Simulation	channelwise
Communication, hardware	for each I/O module

Characteristics at rated conditions

Power consumption	< 2.2 W (for valves >1500 ohms) < 5.6 W (for valves > 275 ohms)
-------------------	--

Valves with input resistance < 270 ohms must not be connected !
(< 270 ohms short circuit detection)

Output for valves from e.g.: Bürkert
(Observe the technical data) Eugen Seitz
Festo
Norgren-Herion
Samsomatic
etc.

We recommend pilot valves >1500 ohms input impedance

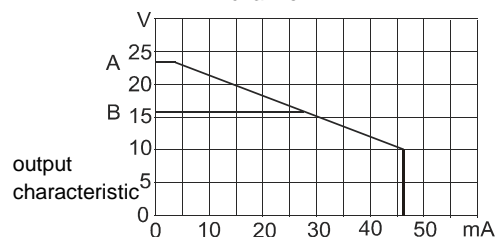
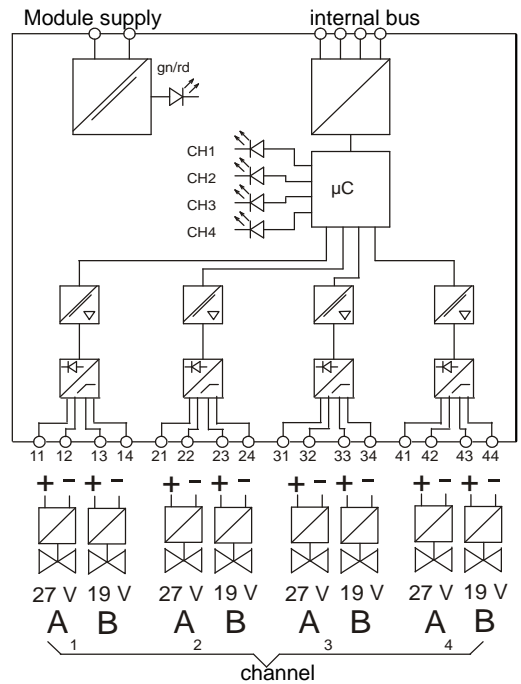
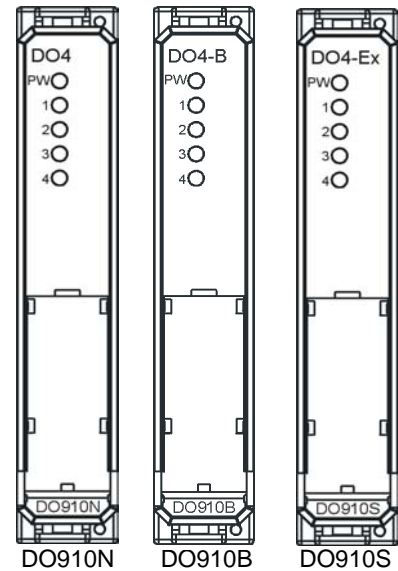

Order No.	DO910S	3KDE175321L9100
	DO910B	3KDE175322L9100
	DO910N	3KDE175323L9100

- Relay output for higher switching power
- Output configurable as NO or NC contact
- Electrical isolation between output / bus and output / power
- Electrical isolation channel to channel
- Configurable as 4 x changeover contact
- Configurable as 6 x NO contact

Technical Data

Output

Switching voltage	max. 60 V DC / 60 V AC min. 12 V DC / 12 V AC
Switching current	max. 1 A (60 V AC, 30 V DC) max. 0.7 A (60 V DC) min. 10 mA (DC) / 10 mA (AC)
Switching delay	> 4 ms ... < 12 ms
Contact type	2 x changeover (channel 1 and 2) 4 x NO contacts (channel 3 to 6) The channels 3+4 and 5+6 resp. are switchable via software as changeover contacts. For this an external bridge is required at the terminals.
Mechanical life time	30 x 10 ⁶ switching cycles

Electrical isolation

Contact circuit to int. bus / module supply	1500 V
between contact circuits	500 V

Diagnosis

System / Module power on	LED green / red
Output on	LED 1...4, yellow
Line break or short circuit	LED 1...4, red

Characteristics at rated conditions

Power consumption	2 W
-------------------	-----

Note:

In order to protection the termination unit, the contact circuits in the DO930 module are fuse-protected (1A slow blow).
Once the fuses are blown, the module must be replaced.

The links between the terminals 12 - 13 or 22 - 23, are not fuse-protected.
The maximum ampacity of these links corresponds to the max. relay switching capacity. Preferably use the terminals 12 and 22 for connecting.

Attention:

DO930 module functionality will be supported from Communication Interface CI920x with Firmware V.1.5.x or higher only!
Observe release Notes CI920 !

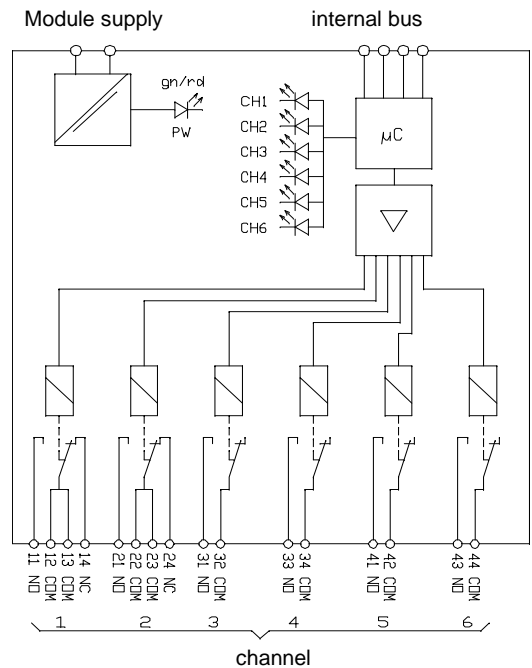
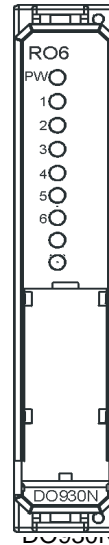

Figure:
Relays in the currentless state

Order No.		
	DO930N	3BDS014114

- Frequency input for dry contacts or proximity switches
- Short and break detection
- Electrical isolation between input / bus and input / power
- Frequency measurement or counting applications
- 2 Function blocks
- Reset via fieldbus or control input
- Status outputs / Direction recognition

Technical Data

Input

No-load voltage	8 V DC
Short-circuit current	4...5 mA
Switching point in range	1.4...1.8 mA
Switching hysteresis	0.2 mA
Short-circuit detection	300...350 ohms
Line-break detection	0.1...0.2 mA
Input frequency	max. 4 kHz
Counter	1,25 kHz w. direction recognition 30 bit (29 bit and digit sign)

Explosion protection (type ...S) PTB 00 ATEX 2180
II 2 (1) G EEx ib [ia] IIC T4

Explosion protection (type ...B) PTB 03 ATEX 2078
II (1) G [EEx ia] IIB/IIC
PTB 03 ATEX 2079
II 3 G EEx nA II T4

Max. short-circuit current	$I_o = 44 \text{ mA}$
Max. voltage	$U_o = 9,6 \text{ V}$
Max. power	$P_o = 106 \text{ mW}$
External inductance	$L_o = 1 \text{ mH}$
External capacitance	$C_o = 1100 \text{ nF}$

Diagnosis

System / Module power on	LED green / red
Open (off)/ closed (on)	LED 1...8, off / yellow
Line break or short circuit	LED 1...8, red

Via fieldbus

Break, short	channelwise
Simulation	blockwise
Alarm, counter over/underflow	approx. 1.2 kg
Communication, hardware	for each I/O module

Characteristics at rated conditions

De-bounce filter, software on/off	0...100 ms
Power consumption	< 1.1 W
Accuracy for frequency measurement	0.1 % / 1 %, depending on time window

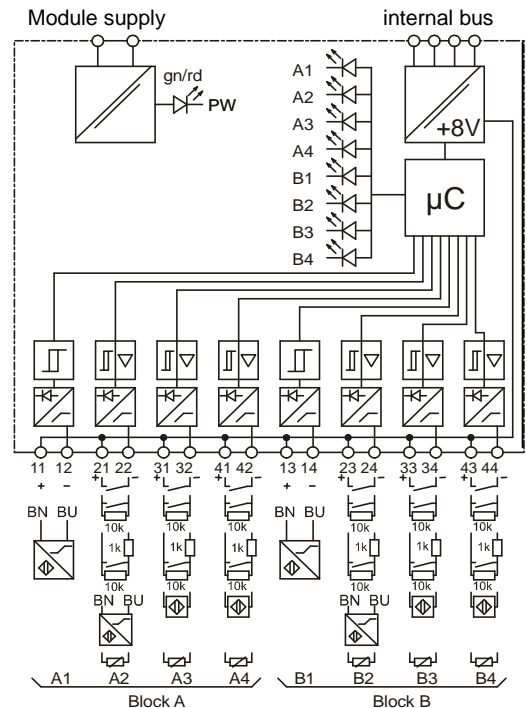
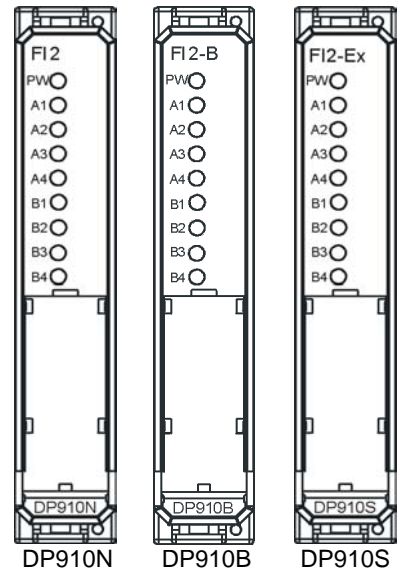

Order No.	DP910S	3KDE175361L9100
	DP910B	3KDE175362L9100
	DP910N	3KDE175363L9100

- Power supply for 4...20 mA loop powered 2-wire transmitters
- Short and break detection
- Electrical isolation between input / bus and input / power
- Common return for all inputs
- 4 channels, EEx ia II C

Technical Data

Input

Input current	4...20 mA
Transmitter supply	> 15 V (20 mA)
Internal current limitation	24...26 mA
Input impedance	240 ohms
Residual ripple	< 100 mV
Short-circuit detection	< 5 V
Line-break detection	< 2 mA

Explosion protection (type ...S) PTB 00 ATEX 2058 X
II 2 (1G/D) G EEx [ia] ib IIC T4

Explosion protection (type ...B) PTB 03 ATEX 2078
II (1) G [EEx ia] IIB/IIC
PTB 03 ATEX 2079
II 3 G EEx nA II T4

Max. short-circuit current	$I_o = 93 \text{ mA}$
Max. voltage	$U_o = 22,1 \text{ V}$
Max. power	$P_o = 640 \text{ mW}$
External inductance	$L_o = 1,78 \text{ mH}$
External capacitance	$C_o = 100 \text{ nF}$

Diagnosis

System / Module power on	LED green / red
Line break or short circuit	LED 1...4, red

Via fieldbus

Break, short	channelwise
Over-/underrange	channelwise
Simulation	channelwise
Communication, hardware	for each I/O module

Characteristics at rated conditions

Accuracy incl. linearity	< 0.1 %
Digital accuracy	14 bit
Linearity	< 0.05 %
Temperature effect	< 0.05 % / 10 K
Response time	50 ms (10% -> 90%)
50/60 Hz filter	> 30 dB
Damping by software	PT1
Power consumption	< 2.5 W (20 mA)

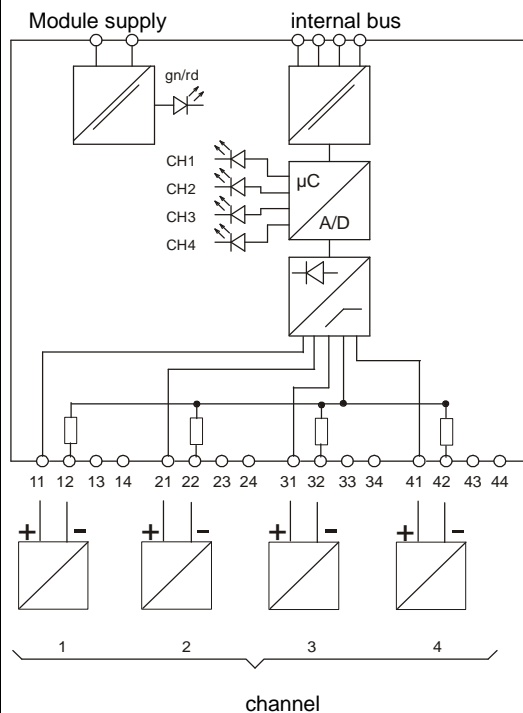
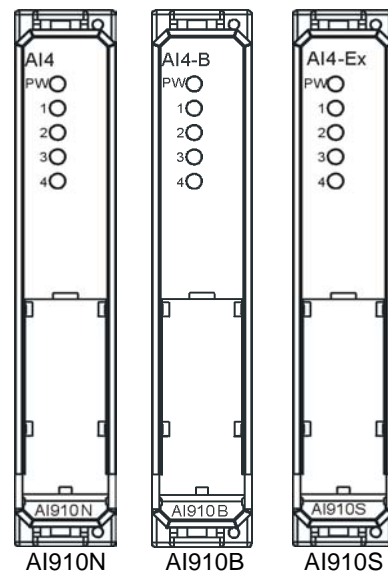

Order No.	AI910S	3KDE175511L9100
	AI910B	3KDE175512L9100
	AI910N	3KDE175513L9100

- Power supply for 4...20 mA loop powered 2-wire transmitters
- Short and break detection
- Electrical isolation between input / bus and input / power
- Common return for all inputs
- 4 channels, EEx ia II C
- Transmission of HART frames via the fieldbus

Technical Data

Input

Input current	4...20 mA
Transmitter supply	> 15 V (20 mA)
Internal current limitation	24...26 mA
Input impedance	240 ohms
Residual ripple	< 100 mV
Short-circuit detection	< 5 V
Line-break detection	< 2 mA

Explosion protection (type ...S) PTB 00 ATEX 2058 X
II 2 (1G/D) G EEx [ia] ib IIC T4

Explosion protection (type ...B) PTB 03 ATEX 2078
II (1) G [EEx ia] IIB/IIC
PTB 03 ATEX 2079
II 3 G EEx nA II T4

Max. short-circuit current	$I_o = 93 \text{ mA}$
Max. voltage	$U_o = 22,1 \text{ V}$
Max. power	$P_o = 640 \text{ mW}$
External inductance	$L_o = 1,78 \text{ mH}$
External capacitance	$C_o = 100 \text{ nF}$

Diagnosis

System / Module power on	LED green / red
Line break or short circuit	LED 1...4, red

Via fieldbus

Break, short	channelwise
Over-/underrange	channelwise
Simulation	channelwise
Communication, hardware	for each I/O module

Characteristics at rated conditions

Accuracy incl. linearity	< 0.1 %
Digital accuracy	14 bit
Linearity	< 0.05 %
Temperature effect	< 0.05 % / 10 K
Response time	50 ms (10% -> 90%)
50/60 Hz filter	> 30 dB
Damping by software	PT1
Power consumption	< 2.5 W (20 mA)

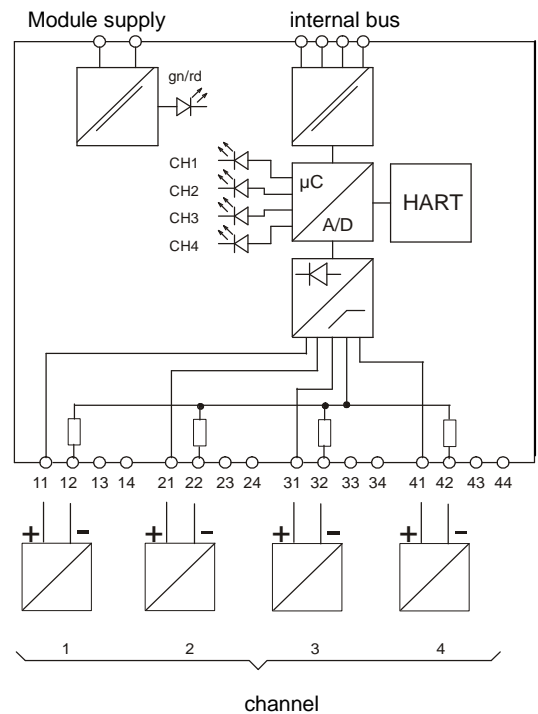
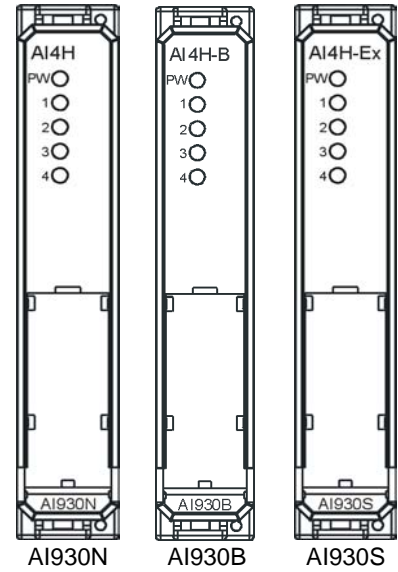

Order No.	AI930S	3KDE175511L9300
	AI930B	3KDE175512L9300
	AI930N	3KDE175513L9300

- Passive inputs for 0/4...20 mA
- Short and break detection
- Electrical isolation between input / bus and input / power
- Common return for all inputs
- 4 channels, EEx ia II C
- Transmission of HART frames via the fieldbus

Technical Data

Input

Input current	0/4...20 mA
Input impedance	240 ohms
Line-break / short circuit det.	< 2 mA (4...20 mA)

Explosion protection (type ...S) PTB 00 ATEX 2058 X
II 2 (1G/D) G EEx [ia] ib IIC T4

Explosion protection (type ...B) PTB 03 ATEX 2078
II (1) G [EEx ia] IIB/IIC
PTB 03 ATEX 2079
II 3 G EEx nA II T4

Max. short-circuit current	$I_o = 16 \text{ mA}$
Max. voltage	$U_o = 7,2 \text{ V}$
Max. power	$P_o = 29 \text{ mW}$

Diagnosis

System / Module power on	LED green / red
Line break or short circuit	LED 1...4, red

Via fieldbus

line-break or short-circuit	channelwise
Over-/underrange	channelwise
Simulation	channelwise
Communication, hardware	for each I/O module

Characteristics at rated conditions

Accuracy incl. linearity	< 0.1 %
Digital accuracy	14 bit
Linearity	< 0.05 %
Temperature effect	< 0.05 % / 10 K
Response time	50 ms (10% -> 90%)
50/60 Hz filter	> 30 dB
Damping by software	PT1
Power consumption	< 0.5 W

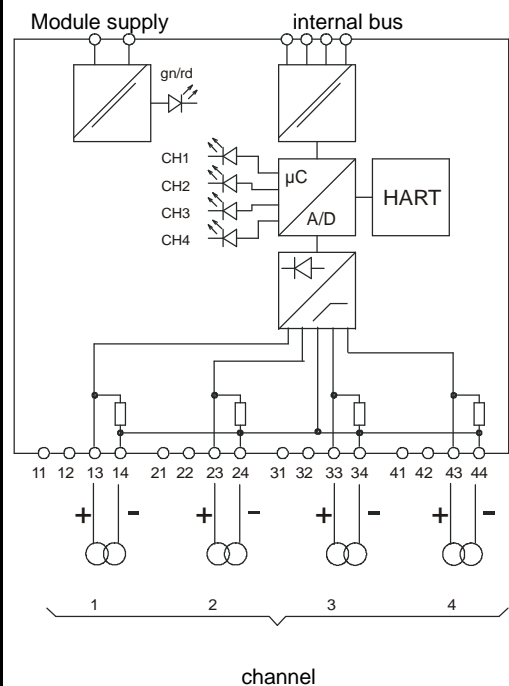
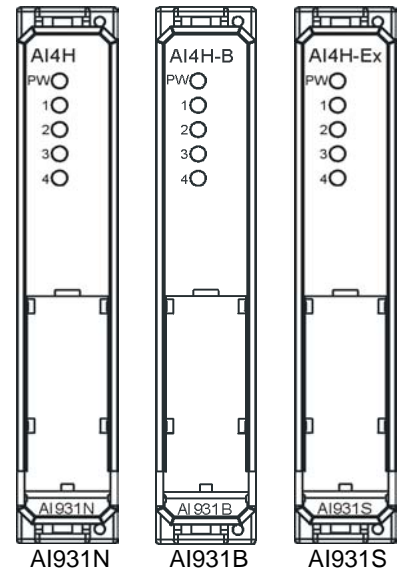

Order No.	AI931S	3KDE175511L9310
	AI931B	3KDE175512L9310
	AI931N	3KDE175513L9310

- Pt 100, Pt 1000, Ni 100, 0...3 kohms in 2/3/4 wire technique
- Thermocouple Type B, E, J, K, L, N, R, S, T, U, mV
- Internal or external cold junction compensation
- Short and break detection
- Electrical isolation between input / bus and input / power
- Electrical isolation channel to channel
- 4 channels, EEx ia II C

Technical Data

Input

Input (Pt 100, Pt 1000)

Wire resistance (4 wire)	< 50 ohms for each wire
Wire resistance (3 wire)	0...10 ohms symmetric
Wire resistance (2 wire)	< 10 ohms
Short-circuit detection	< 5 ohms
Sensor, line-break detection	> 10 kohms

Input (Thermocouple)

Line-break detection	< 100 nA, > 150 mV
----------------------	--------------------

Explosion protection (type ...S) PTB 00 ATEX 2182
II 2(1) G EEx ib [ia] IIC T4

Explosion protection (type ...B) PTB 00 ATEX 2078
II (1) G [EEx ia] IIB/IIC
PTB 00 ATEX 2079
II 3 G EEx nA II T4

Max. short-circuit current	$I_o = 25 \text{ mA}$
Max. voltage	$U_o = 5,5 \text{ V}$
Max. power	$P_o = 35 \text{ mW}$
External inductance	$L_o = 2 \text{ mH}$
External capacitance	$C_o = 1600 \text{ nF}$

Diagnosis

System / Module power on	LED green / red
Line break or short circuit	LED 1...4, red

Via fieldbus

Break, short	channelwise
Over-/underrange	channelwise
Simulation	channelwise
Communication, hardware	for each I/O module

Characteristics at rated conditions

Calibrated accuracy	< 0.2K, < 80 mohms, < 0.01 mV
Digital accuracy	16 bit
Linearity	< 0.05 %
Temperature effect	< 0.05 % / 10 K
Response time	1 s (10% -> 90%)
50/60 Hz filter	> 40 dB
Damping by software	PT1
Power consumption	< 0.7 W

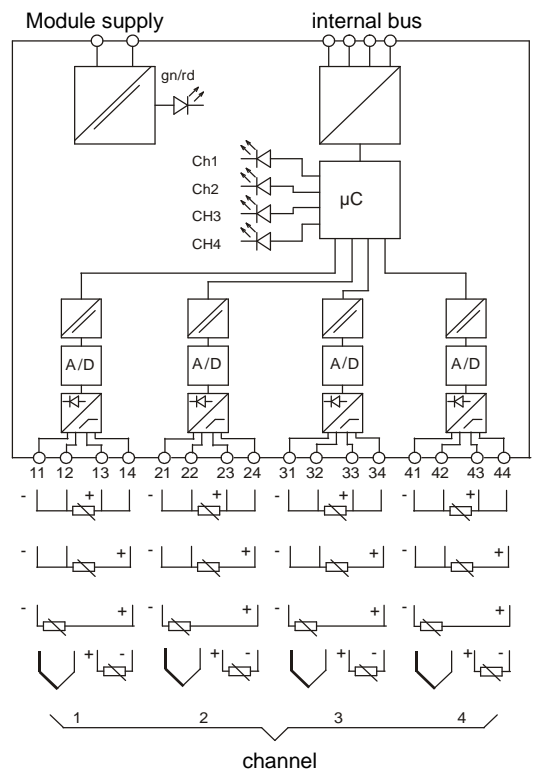
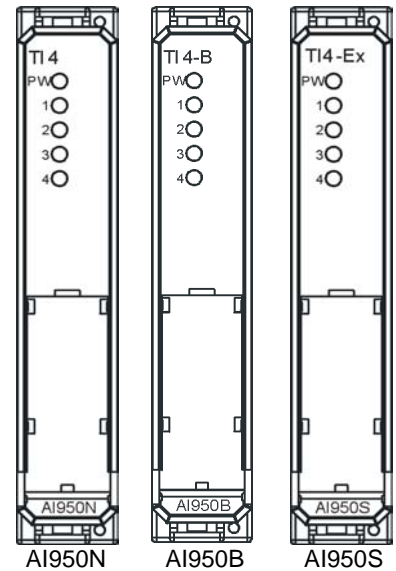

Order No.	AI950S	3KDE175521L9500
	AI950B	3KDE175522L9500
	AI950N	3KDE175523L9500

- Output signal 0/4...20 mA for actuators
- Short and break detection
- Electrical isolation between output / bus and output / power
- Output with common ground
- 4 channels, EEx ia II C

Technical Data

Output

Output current	0/4...20 mA
Range	0...24 mA
Load	700 ohms (20 mA)
Short-circuit detection	< 30 ohms ($I_a > 2$ mA)
Line-break detection	15...18 V

Explosion protection (type ...S) PTB 02 ATEX 2029
II 2 (1G/D) G EEx [ia] ib IIC T4

Explosion protection (type ...B) PTB 03 ATEX 2078
II (1) G [EEx ia] IIB/IIC
PTB 03 ATEX 2079
II 3 G EEx nA II T4

Max. short-circuit current	$I_o = 93$ mA
Max. voltage	$U_o = 22,1$ V
Max. power	$P_o = 640$ mW
External inductance	$L_o = 1,78$ mH
External capacitance	$C_o = 100$ nF

Diagnosis

System / Module power on	LED green / red
Line break or short circuit	LED 1...4, red

Via fieldbus

Break, short	channelwise
Simulation	channelwise
Communication, hardware	for each I/O module

Characteristics at rated conditions

Accuracy incl. linearity	< 0.1 %
Digital accuracy	13 bit
Linearity	< 0.05 %
Temperature effect	< 0.05 % / 10 K
Response time	50 ms (10% -> 90%)
Power consumption	< 2.5 W (20 mA)

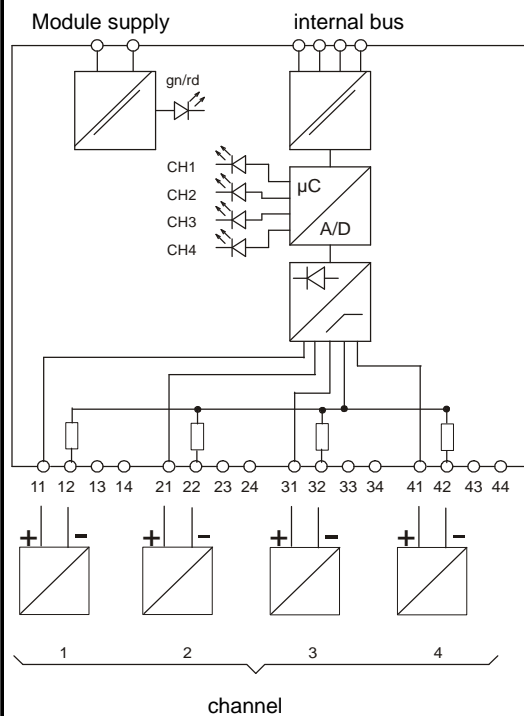
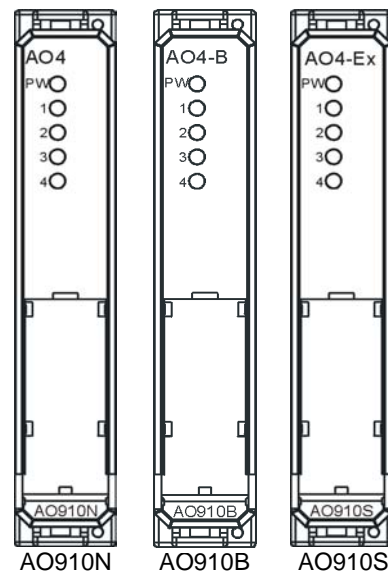

Order No.	AO910S	3KDE175531L9100
	AO910B	3KDE175532L9100
	AO910N	3KDE175533L9100

- Output signal 0/4...20 mA for actuators
- Short and break detection
- Electrical isolation between output / bus and output / power
- Electrical isolation channel to channel
- 4 channels, EEx ia II C

Technical Data

Output

Output current	0/4...20 mA
Range	0...24 mA
Load	700 ohms (20 mA)
Short-circuit detection	100...180 ohms
Line-break detection	< 2 mA

Explosion protection (type ...S) PTB 00 ATEX 2200
II 2 (1) G EEx e ib [ia] II C T4

Explosion protection (type ...B) PTB 03 ATEX 2078
II (1) G [EEx ia] IIB/IIC
PTB 03 ATEX 2079
II 3 G EEx nA II T4

Max. short-circuit current	$I_o = 80 \text{ mA}$
Max. voltage	$U_o = 18,9 \text{ V}$
Max. power	$P_o = 510 \text{ mW}$
External inductance	$L_o = 2 \text{ mH}$
External capacitance	$C_o = 100 \text{ nF}$

Diagnosis

System / Module power on	LED green / red
Line break or short circuit	LED 1...4, red

Via fieldbus

Break, short	channelwise
Simulation	channelwise
Communication, hardware	for each I/O module

Characteristics at rated conditions

Accuracy incl. linearity	< 0.1 %
Digital accuracy	13 bit
Linearity	< 0.05 %
Temperature effect	< 0.05 % / 10 K
Response time	50 ms (10% -> 90%)
Power consumption	< 3.3 W (20 mA)

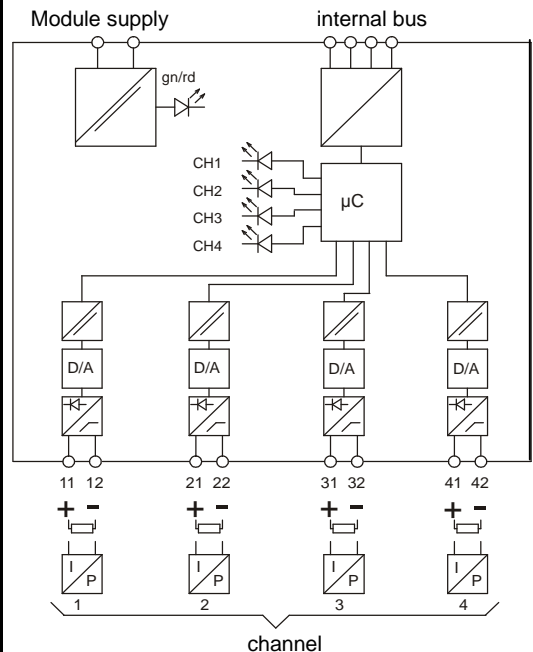
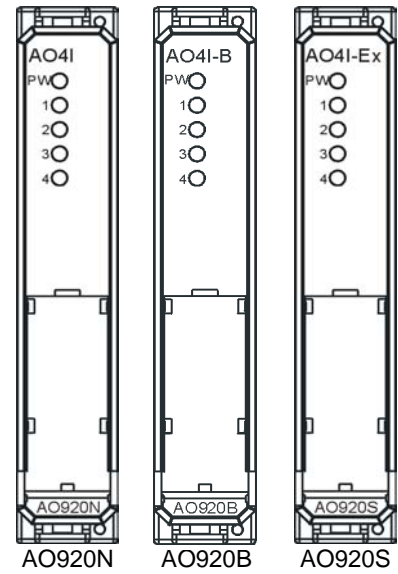

Order No.	AO920S	3KDE175531L9200
	AO920B	3KDE175532L9200
	AO920N	3KDE175533L9200

- Output signal 0/4...20 mA for actuators
- Short and break detection
- Electrical isolation between output / bus and output / power
- Output with common ground
- 4 channels, EEx ia II C
- Transmission of HART frames via the fieldbus

Technical Data

Output

Output current	0/4...20 mA
Range	0...24 mA
Load	700 ohms (20 mA)
Short-circuit detection	< 30 ohms ($I_a > 2$ mA)
Line-break detection	15...18 V

Explosion protection (type ...S) PTB 02 ATEX 2029
II 2 (1G/D) G EEx [ia] ib IIC T4

Explosion protection (type ...B) PTB 03 ATEX 2078
II (1) G [EEx ia] IIB/IIC
PTB 03 ATEX 2079
II 3 G EEx nA II T4

Max. short-circuit current	$I_o = 93$ mA
Max. voltage	$U_o = 22,1$ V
Max. power	$P_o = 640$ mW
External inductance	$L_o = 1,78$ mH
External capacitance	$C_o = 100$ nF

Diagnosis

System / Module power on	LED green / red
Line break or short circuit	LED 1...4, red

Via fieldbus

Break, short	channelwise
Simulation	channelwise
Communication, hardware	for each I/O module

Characteristics at rated conditions

Accuracy incl. linearity	< 0.1 %
Digital accuracy	13 bit
Linearity	< 0.05 %
Temperature effect	< 0.05 % / 10 K
Response time	50 ms (10% -> 90%) 200 ms (for HART)

Power consumption < 2.5 W (20 mA)

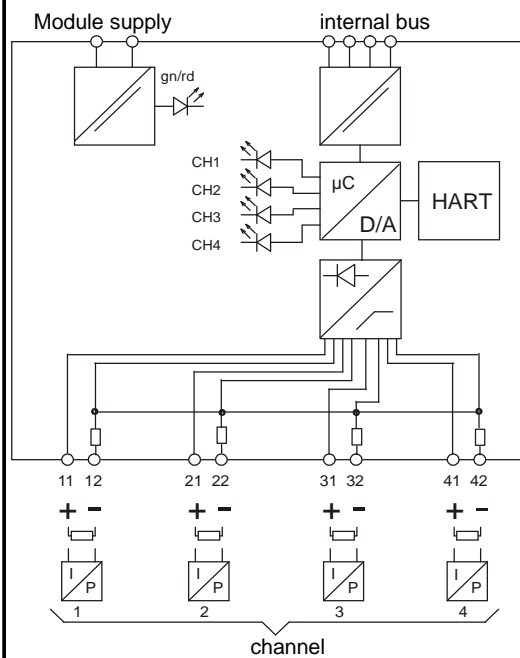
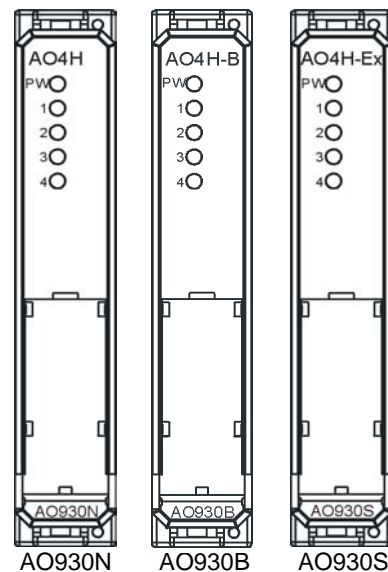

Order No.	AO930S	3KDE175531L9300
	AO930B	3KDE175532L9300
	AO930N	3KDE175533L9300

S900 Ex devices Zone 1	Page 40
S900 Ex devices Zone 2	Page 41
S900 Safe area devices	Page 42

Ordering information

Ex zone 1/1 system components

Ordering information		Catalog No.
Type	Designation	
TU921S	Redundant Termination Unit (TU16R-Ex) for 16 I/O-modules redundant communication and power (Delivery includes CD910)	3KDE175111L9210
SA920S	Power Supply for 24 V DC The power supply filter, type BP901S, is not required. Do not mix SA920S with SA910S for redundancy!	3BDH000602R1
SA910S	Power Supply (PS24-Ex) (classic) for 24 V DC The power supply filter, type BP901S, is required. Do not mix SA910S with SA920S for redundancy!	3KDE175131L9100
CI920S	Communication Interface V.1.5.x (CIPB-Ex) use only CI920S with the same firmware for redundancy for PROFIBUS-DP V1 (observe release notes)	3BDS014111
CI920S	Communication Interface V.1.4.x (CIPB-Ex) use only CI920S with the same firmware for redundancy for PROFIBUS-DP V1 (observe release notes)	3KDE175121L920
DX910S	Digital Input or Output (DIO8-Ex) input for dry contact or NAMUR initiator output for low power I.S. valves	3KDE175311L9100
DO910S	Solenoid Driver (DO4-Ex) output for I.S. valves	3KDE175321L9100
DP910S	Frequency Input (FI2-Ex) input for dry contact or NAMUR initiator	3KDE175361L9100
AI910S	Analog input (AI4-Ex) transmitter power supply, 4...20 mA, for 2-wire transmitters	3KDE175511L9100
AI930S	Analog Input, HART® (AI4H-Ex) transmitter power supply, 4...20 mA, for 2-wire transmitters	3KDE175511L9300
AI931S	Analog Input, HART® (AI4H-Ex) passive input, 0/4...20 mA	3KDE175511L9310
AI950S	Temperature Input (TI4-Ex) Pt100, Pt1000, Ni100 in 2-/3-/4-technology thermocouples type B, E, J, K, L, N, R, S, T isolated inputs channel by channel	3KDE175521L9500
AO910S	Analog output (AO4-Ex) output 0/4...20 mA, for final control elements	3KDE175531L9100
AO920S	Analog output, isolated (AO4I-Ex) output 0/4...20 mA, for final control elements isolated outputs channel by channel	3KDE175531L9200
AO930S	Analog output HART® (AO4H-Ex) output 0/4...20 mA, for final control elements	3KDE175531L9300
CB220S	Compact Box for power supply SA911S, communication interface CI920S and four I/O modules S900 type S (Delivery includes CD910)	3KDE175611L2210
SA911S	Power supply for CB220S for 24 V DC the power supply filter, type BP901S, is not required	3KDE175611L9110
	Field Housing with completely installed S900 incl. documentation - see price list S900 field housing	

Ex zone 2/1 system components

Ordering information		Catalog No.
Type	Designation	
TU921B	Redundant Termination Unit (TU16R-B) for 16 I/O-modules redundant communication and power (Delivery includes CD910)	3KDE175112L9210
SA920B	Power Supply for 24 V DC The power supply filter, type BP901S, is not required. Do not mix SA920B with SA910B for redundancy!	3BDH000601R1
SA910B	Power Supply (PS24-B) (classic) for 24 V DC The power supply filter, type BP901S, is <u>not</u> required. Do not mix SA910B with SA920B for redundancy!	3KDE175132L9100
Ci920B	Communication Interface V.1.5.x (CIPB-B) use only Ci920B with the same firmware for redundancy for PROFIBUS-DP V1 (observe release notes)	3BDS014112
Ci920B	Communication Interface V.1.4.x (CIPB-B) use only Ci920B with the same firmware for redundancy for PROFIBUS-DP V1 (observe release notes)	3KDE175122L9200
DX910B	Digital Input or Output (DIO8-B) input for dry contact or NAMUR initiator output for low power I.S. valves	3KDE175312L9100
DO910B	Solenoid Driver (DO4-B) output for I.S. valves	3KDE175322L9100
DP910B	Frequency Input (FI2-B) input for dry contact or NAMUR initiator	3KDE175362L9100
AI910B	Analog input (AI4-B) transmitter power supply, 4..20 mA, for 2-wire transmitters	3KDE175512L9100
AI930B	Analog Input, HART® (AI4H-B) transmitter power supply, 4..20 mA, for 2-wire transmitters	3KDE175512L9300
AI931B	Analog Input, HART® (AI4H-B) passive input, 0/4..20 mA	3KDE175512L9310
AI950B	Temperature Input (TI4-B) Pt100, Pt1000, Ni100 in 2-/3-/4-technology thermocouples type B, E, J, K, L, N, R, S, T isolated inputs channel by channel	3KDE175522L9500
AO910B	Analog output (AO4-B) output 0/4..20 mA, for final control elements	3KDE175532L9100
AO920B	Analog output, isolated (AO4I-B) output 0/4..20 mA, for final control elements isolated outputs channel by channel	3KDE175532L9200
AO930B	Analog output HART® (AO4H-B) output 0/4..20 mA, for final control elements	3KDE175532L9300
CB220B	Compact Box for power supply SA911B, communication interface Ci920B and four I/O modules S900 type B (Delivery includes CD910)	3KDE175612L2210
SA911B	Power supply for CB220B for 24 V DC the power supply filter, type BP901S, is not required	3KDE175612L9110

Ordering information

Safe area system components

Ordering information		Catalog No.
Type	Designation	
TU921N	Redundant Termination Unit (TU16R) for 16 I/O-modules redundant communication and power (Delivery includes CD910)	3KDE175113L9210
SA920N	Power Supply for 24 V DC The power supply filter, type BP901S, is not required. Do not mix SA920N with SA910N for redundancy!	3BDH000600R1
SA910N	Power Supply (PS24-N) (classic) for 24 V DC The power supply filter, type BP901S, is <u>not</u> required. Do not mix SA910N with SA920N for redundancy!	3KDE175133L9100
C1920N	Communication Interface V.1.5.x (CIPB) use only C1920N with the same firmware for redundancy for PROFIBUS-DP V1 (observe release notes)	3BDS014113
C1920N	Communication Interface V.1.4.x (CIPB) use only C1920N with the same firmware for redundancy for PROFIBUS-DP V1 (observe release notes)	3KDE175123L9200
DX910N	Digital Input or Output (DIO8) input for dry contact or NAMUR initiator output for low power valves	3KDE175313L9100
DO910N	Solenoid Driver (DO4) output for valves	3KDE175323L9100
DO930N	Relay Output (RO6) with 4 normally-open contacts and 2 changeover contacts	3BDS014114
DP910N	Frequency Input (FI2) input for dry contact or NAMUR initiator	3KDE175363L9100
AI910N	Analog input (AI4) transmitter power supply, 4...20 mA, for 2-wire transmitters	3KDE175513L9100
AI930N	Analog Input, HART® (AI4H) transmitter power supply, 4...20 mA, for 2-wire transmitters	3KDE175513L9300
AI931N	Analog Input, HART® (AI4H) passive input, 0/4...20 mA	3KDE175513L9310
AI950N	Temperature Input (TI4) Pt100, Pt1000, Ni100 in 2-/3-/4-technology thermocouples type B, E, J, K, L, N, R, S, T isolated inputs channel by channel	3KDE175523L9500
AO910N	Analog output (AO4) output 0/4...20 mA, for final control elements	3KDE175533L9100
AO920N	Analog output, isolated (AO4I) output 0/4...20 mA, for final control elements isolated outputs channel by channel	3KDE175533L9200
AO930N	Analog output HART® (AO4H) output 0/4...20 mA, for final control elements	3KDE175533L9300
CB220N	Compact Box for power supply SA911N, communication interface C1920N and four I/O modules S900 type N (Delivery includes CD910)	3KDE175613L2210
SA911N	Power supply for CB220N for 24 V DC the power supply filter, type BP901S, is not required	3KDE175613L9110

Fieldbus isolating repeater

Page 44

Accessories and software

Page 45

Fieldbus isolating repeater

Fieldbus isolating repeater ordering information		Catalog No.
Type	Designation	
BI914S	Fieldbus isolating repeater separates one intrinsically safe RS485 fieldbus segment from a non intrinsically safe RS485 fieldbus DIN rail housing with IP20 protection	3BDH000649R1
BI923S	Ring-coupler RS485 / FO - intrinsically safe - Slave separates an intrinsically safe fibre optic ring from a non intrinsically safe RS485 interface BARTEC - 07-7311-97WP5000 integrated in DIN rail mounted housing with IP20 protection (Slave)	3KDE175831L9230
BI924S	Ring-coupler RS485 / FO intrinsically safe - Master separates an intrinsically safe fibre optic ring from a non intrinsically safe RS485 interface BARTEC - 07-7311-97WP5200 integrated in DIN rail mounted housing with IP20 protection (Master)	3KDE175831L9240
BI933S	Ring-coupler IS-RS485 / FO ring intrinsically safe separates an intrinsically safe fibre optic ring from an intrinsically safe RS485 interface integrated in separate field housing BARTEC - 07-3103-2512/177M (Slave)	3KDE175831L9330

Accessories and Software

Accessories ordering information		Catalog No.
Type	Designation	
BP910S	Intrinsically safe PROFIBUS-DP connector D-SUB Connector (color blue) for use with the intrinsically safe PROFIBUS-DP	3KDE175831L9100
BP901S	Power supply filter (classic) One filter is necessary for each power supply SA910S	3KDE175831L9010
IP920	Module housing IP20 protection for empty slots of the termination unit for use in S900 S, B, and N systems	3KDE175831L9200
IL910	Insert labels 320 pcs.	3KDE175839L9101

Software ordering information		Catalog No.
Type	Designation	
BI992	ABB DTM S900 DP - licence for parameterization and configuration of the S900 station FDT 1.2, for all PROFIBUS addresses including HART® (see release notes)	3KDE175839L9920
CD910	Additional software CD ROM incl. S900 Documentation, Certificates, GSD (file) ABB DTM S900 DP and Software Tools CD ROM will be delivered with all TU921 and CB220	3KDE175839L9100

Coding	Page 48
Mounting in hazardous areas	Page 49
Safety and precautions	Page 49

Coding proposal

Proposal 1 (Ex / non-Ex)

Ex module	Position 1
non-Ex module	Position 4

Proposal 2 (module type)

AI active (AI910, AI920, AI930)	Position 1
AI passive (AI931)	Position 2
AO (AO910, AO920, AO930)	Position 3
DIO/FI (DX910, DP910)	Position 4
DO (DO910, DO930)	Position 5
TI (AI950)	Position 6

The user is free to select any of the 6 possible coding options shown on the right-hand side.

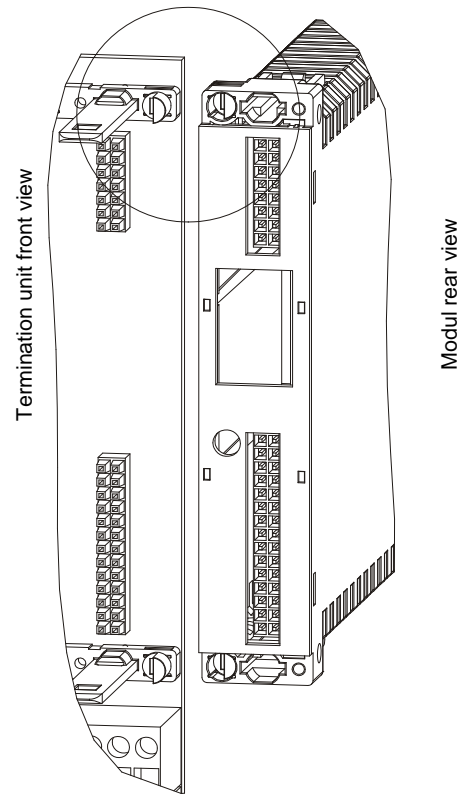

Position 1

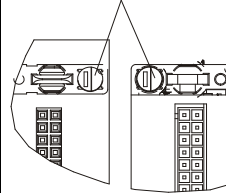

Position 2

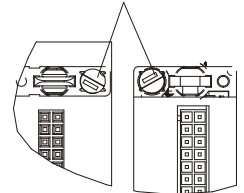

Position 3

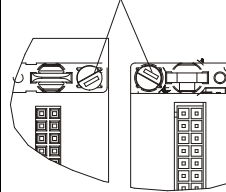

Position 4

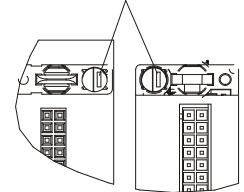

Position 5

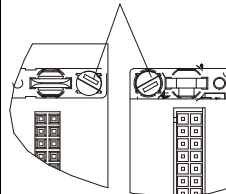

Position 6

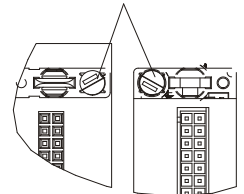

Mounting in hazardous areas

The S900 Remote I/O System can be mounted in safe and in hazardous areas (ATEX zone 1 and zone 2). Observe the general regulations and directives for electrical apparatus used in hazardous areas according to EN 50014 (VDE 0170/0171 Part 2).

On the customer side, explosion protection classes "e" (increased safety) and "i" (intrinsic safety) are applicable for the S900 Remote I/O System.

The power supply circuits on the S900 termination unit must meet the requirements of explosion protection class "e". Observe the directives and regulations specified in EN 60079-14 (VDE 0165 Part 1), especially Section 11 (Special requirements for explosion protection class "e" – Increased safety).

The field current circuits on the S900 termination unit must meet the requirements of explosion protection class "i". Observe the directives and regulations specified in EN 60079-14 (VDE 0165 Part 1), especially Section 12 (Special requirements for explosion protection class "i" – Intrinsic safety).

Safety and precautions

For mounting in hazardous areas be sure to observe the following safety instructions:

Safe and proper operation of the S900 Remote I/O System requires proper transportation and storage, installation and commissioning by qualified personnel, proper use and careful maintenance.

The S900 Remote I/O System components have been designed, produced and tested in accordance with IEC 61010-1 (corresponding to DIN/EN 61010-1 or VDE 0411, Part 1 "Safety Requirements for Electrical Measuring, Control and Laboratory Apparatus), have a CE certificate, and have been supplied in a safe condition.

When using the device (i.e. transporting, storing, installing, commissioning, operating or maintaining it or putting it out of operation) observe the operating instructions (3BDD010421R0101) and the instructions given on the type plates, labels and safety notes attached to the device in order to retain the device in a safe condition and to ensure safe operation. Otherwise, persons may be injured, or the device itself or other devices or installations may be damaged or fail.

The regulations, standards and directives referred to in this product catalog and in the operating instructions (3BDD010421R0101) are applicable in Germany. When using the device in any other countries, the relevant regulations, standards and directives applicable in the country where the device is used must be observed.

The connected devices must meet the requirements of VDE 0106 T.101 (basic requirements of protective separation) to achieve protective separation of live current circuits. To ensure protective separation, always lay feed cables separately from live current circuits or provide an additional insulation.

Prior to switching on the device make sure that the ambient conditions are in accordance with the device's environmental capabilities specified under "Technical data", and that the mains voltage is identical with the specified S900 Remote I/O System voltage.

If you are in doubt whether the device is still working safely or safe operation can no longer be ensured, immediately put the device out of operation and secure it against accidental operation.



Observe the instructions given in the manuals referenced in this product catalog. Additionally observe:

- the relevant safety regulations, directives and standards for the installation and operation of electrical systems
- the regulations, directives and standards related to explosion protection
- the conformity compliance information of the individual S900 Remote I/O System components used in hazardous areas
- the installation and commissioning instructions in the S900 Remote I/O System User's Guide (3BDD010421R0101)

If you should need any information which is not contained in this product catalog or in the relevant operating instructions (3BDD010421R0101) please contact the vendor. Refer to the back side of this catalog for the vendor addresses.

For the latest information on ABB visit us on the World Wide Web at <http://www.abb.com>



Automation Technologies
Västerås, Sweden
Phone: +46 (0)21 34 20 00
Fax: +46 (0)21 13 78 45

www.abb.com/controlsystems

e-mail: processautomation@se.abb.com

Automation Technologies
Wickliffe, Ohio, USA
Phone: +1 440 585 8500
Fax: +1 440 585 8756

www.abb.com/controlsystems

e-mail: industrialitsolutions@us.abb.com

Automation Technologies
Mannheim, Germany
Phone: +49 (0) 1805 26 67 76
Fax: +49 (0) 1805 77 63 29

www.abb.com/controlsystems

e-mail: marketing.control-products@de.abb.com

3BDD010420R0601

©Copyright 2008 ABB.

All rights reserved. Specifications subject to change without notice. Pictures, schematics, and other graphics contained herein are published for illustration purposes only and do not represent product configurations or functionality. User documentation accompanying the product is the exclusive source for functionality descriptions.

The IndustrialIT wordmark, Aspect Objects, and all above-mentioned names in the form OperateIT are registered or pending trademarks of ABB. All rights to other trademarks reside with their respective owners.