

We reserve all rights in this document and in the information contained therein. Reproduction, use in documents or in any form without the written authority of ABB Automation Technologies AB is strictly forbidden.

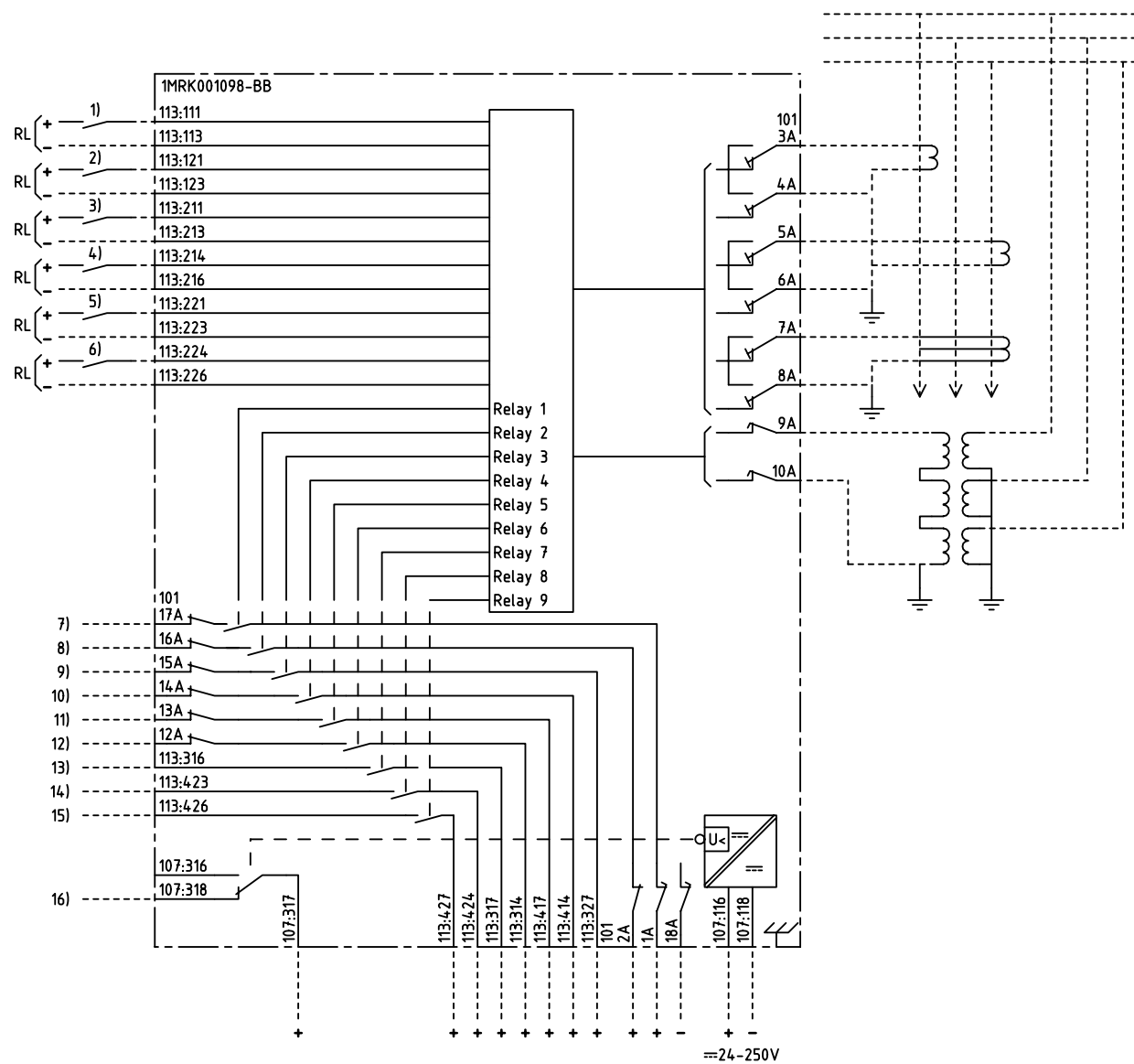

**MULTI-FUNCTION OVERCURRENT AND DIR. EARTH-FAULT PROTECTION WITH BINARY I/O MODULE**

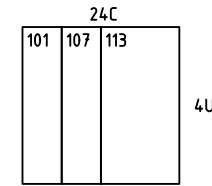

101 RTXP 18  
107 RXTUG 22H  
113 RXHL 421

- 1)-6) BINARY INPUT, PROGRAMMABLE
- 7)-15) RELAY OUTPUTS 1-9, PROGRAMMABLE FUNCTION
- 16) LOSS OF AUXILIARY VOLTAGE

**PROGRAMMABLE FUNCTIONS FOR BINARY INPUTS:**  
BLOCKING/ENABLING I>, I>>, I>>>, DIR. IN>, UN>  
THERMAL RESET  $\theta$ , BREAKER FAILURE EXTERNAL START,  
CHANGING OF CHARACTERISTIC ANGLE  $\alpha$  0° TO 90° OR -90° TO 0°;  
ALTERNATIVE SETTINGS; RESET OF LED INDICATIONS.

**PROGRAMMABLE FUNCTIONS FOR BINARY OUTPUTS:**  
START AND TRIP I>, I>>, I>>>, DIR. IN>, UN>;  
THERMAL ALARM  $\theta$ ; THERMAL TRIP  $\theta$ ;  
BREAKER FAILURE RE-TRIP; BREAKER FAILURE BACK-UP TRIP;  
ALTERNATIVE SETTINGS; IN SERVICE

**BINARY INPUT OPTIONS:**  
CIRCUIT-BREAKER CLOSED; CIRCUIT-BREAKER READY;  
BLOCKING OF AUTORECLOSING; AUTORECLOSING EXTERNAL ON.

**BINARY OUTPUT OPTIONS:**  
AUTORECLOSING ON; AUTORECLOSING READY;  
AUTORECLOSING STARTED;  
AUTORECLOSING PULSE TO CIRCUIT-BREAKER;  
AUTORECLOSING UNSUCCESSFUL; INTENTIONAL OVERREACH TRIP.

Customer drw no	Prep. PTUA/ TPTD H Raza/JE 2000-05-29	Connection Diagram	Cont. sh/ No of sh			
	Appr. PTUA/ Roger Karlsson 2000-05-29			Multi-f dir. O/C prot.		
	Resp. dept PTUA/ TPTD					
Based on	<b>ABB</b> ABB Automation Technologies		Document number <b>1MRK001098-BBA</b>	Lang. en	Rev. A	Sheet 1

Document status: Approved