

xx02000677.jpg

## Features

- Sensitive protection for bearings of large rotating machines
- Operates for shaft currents larger than 0.4-1.0 A AC, depending on the diameter of the shaft
- Fundamental or third harmonic operating principle
- AC or DC powered, galvanically isolated
- Shaft current transformer with test winding
- Can be applied to shafts with diameters up to 2960 mm
- Settable time delay
- Trip relay with heavy duty contacts and indicating flag
- Test switch

## Application

If the bearing insulation on rotating machines breaks down, the voltage induced between the shaft ends, due to machine dissymmetries, creates a shaft current that can damage the bearings. The damage depends on the magnitude and duration of the shaft current. It is therefore desirable to provide sensitive protection that can detect shaft currents of 1 A or less.

The shaft current measuring principle enables more sensitive protection than shaft voltage measurements or vibration monitoring. Vibration monitors only operate after the bearing is damaged. By applying the shaft current protection RARIC together with a special current transformer ILDD, the machine can be tripped and the cause of the bearing insulation breakdown can be eliminated before the bearing is damaged.

The RARIC protection is available in two versions. Version 1, most common, has a linear frequency characteristic and operates on the fundamental and harmonic components of the shaft current. If the lowest setting 0.5 mA

can be used (small disturbances), the protection can detect primary shaft currents of 0.4-1.0 A at machines with shaft diameters in the range 160 to 2960 mm.

Version 2 is used when the shaft current transformer is exposed to large fundamental leakage flux from the machine. This version measures the third harmonic component of the shaft current and can, at its lowest setting, (0.5 mA) detect primary shaft currents of 0.4-1.0 A, 150 Hz. The shaft voltage must contain a third harmonic component if version 2 is to be used.

The shaft current transformer type ILDD required for the relay measurement of the shaft current is a special designed transformer. It is ring shaped to be mounted around the shaft. Depending on the size of the diameter it is split up in two or four (> 2000 mm) sections.

To avoid disturbances the shaft current transformer shall be mounted on that side of the machine which is free from field bars.

## Design

The RARIC protection is built up of a test switch, terminal bases, plug-in modules and connection parts in the COMBIFLEX mounting system. It includes the test switch RTXP 18, an AC/DC converter RXTUB 2 or a DC/DC converter RXTUG 22H, an overcurrent relay RXIK 1, a time relay RXKL 1 and a trip relay RXME 18 with heavy-duty contacts and an indicating red flag.

Version 2 also includes a filter unit RXTFB 4 which attenuates the fundamental current into the overcurrent relay.

The overcurrent relay RXIK 1 includes surge suppression filtering on the input and the operation of its output relay is maintained even in cases of intermittent shaft currents.

The required time delay for tripping is provided by the time relay RXKL 1. The contacts of the trip relay RXME 18 can be connected for alarm or tripping. A hand reset red flag indicates operation.

The shaft current transformer ILDD is available with diameters from 160 to 3000 mm. The transformer is made in two or four (> 2000 mm) sections for mounting between the rotor and the nearest bearing on the turbine side of the rotor which is free from field bars.

The transformer is of special design with a core of high quality magnetic iron. It has an uniformly distributed measuring winding. The number of turns and the core cross section area is matched to the overcurrent relay RXIK 1 for highest possible sensitivity. The transformer has also a test winding for simple testing of the protection.

To mount the shaft current transformer around the shaft, an axial distance of 250 mm or more is recommended. The inner diameter of the transformer should be 20-50 mm larger than the shaft diameter,

The test switch RTXP 18 enables a complete test of RARIC and the shaft current transformer ILDD.

## Technical data

**Table 1: Basic data**

|   |   |
|---|---|
| Current setting range (RXIK)  | 0,5-2 mA, 50-60 Hz  |
| Operate shaft current at setting<br>0,5 mA and transformer diameters<br>160-3000 mm   | Version 1: 0.4-1.0 A, 50-60 Hz<br>Version 2: 0.4-1.0 A, 150 Hz  |
| Reset ratio   | > 99%   |
| Filter characteristic, version 2  | The filter rejects the fundamental by 70:1  |
| Input impedance   | 80 ohm resistive  |
| Overload capacity<br>shaft diameter < 700 mm<br>shaft diameter 700-1600 mm<br>shaft diameter 1610-2500 mm<br>shaft diameter > 2500 mm | 50 A shaft current continuously and 200 A in 1 s<br>65 A shaft current continuously and 250 A in 1 s<br>75 A shaft current continuously and 300 A in 1 s<br>100 A shaft current continuously and 400 A in 1 s |
| Auxiliary rated voltage   | 100, 110 and 220 V, 50-60 Hz or 24-250 V DC   |
| Power consumption from aux.voltage<br>AC supply<br>DC supply  | Approx. 2 VA before and 8 VA after operation<br>Approx. 3 W before and 7 W after operation  |
| Time setting range (RXKL)   | 30 ms-99 h  |
| Permissible ambient temperature   | -5 to +55 °C  |
| Permissible range auxiliary voltage<br>supply   | 80-110% of rated voltage  |

**Table 2: Electromagnetic compatibility tests**

|                                     |                   |
|-------------------------------------|-------------------|
| Power frequency test (SS 436 15 03) | 0.5 kV, class PL4 |
| Fast transient test (SS 436 15 03)  | 4-8 kV, class PL4 |
| 1 MHz burst test (IEC 60255-22-1)   | 2.5 kV, class III |

**Table 3: Insulating tests (IEC 60255-5)**

|                      |                               |
|----------------------|-------------------------------|
| Dielectric test      | 2 kV, 50 Hz, 1 min            |
| Impulse voltage test | 5.0 kV, 1.2/50 $\mu$ s, 0.5 J |

**Table 4: Contact data**

| <b>Trip circuits (RXME 18)</b>                       |  |
|--|--|
| Max system voltage within a contact set              | 450 V dc, 400 V ac   |
| Current-carrying capacity for already closed contact | 55 A for 200 ms<br>30 A for 1 s<br>6 A continuously                            |
| Making and conducting capacity, L/R < 10 ms          | 30 A for 200 ms<br>20 A for 1 s  |
| Breaking capacity, max. 250 Vac, PF > 0.1            | 20 A   |
| Breaking capacity, dc, L/R < 40 ms                   | 20 A at 24 V<br>18 A at 48 V<br>3 A at 110 V<br>1 A at 220 V                   |
| <b>Alarm circuits (RXKL1, RXTUG22H/RXIK1)</b>        |  |
| Max. system voltage within a contact set             | 250/250 V dc<br>250/250 V ac   |
| Current-carrying capacity for already closed contact | 30/- A for 200 ms<br>15/10 A for 1 s<br>5/4 A continuously                     |
| Making and conducting capacity, L/R < 10 ms          | 30/20 A for 200 ms<br>10/10 A for 1 s  |
| Breaking capacity, dc, L/R < 40 ms                   | 2/1.5 A at 24 V<br>1/0.5 A at 48 V<br>0.4/0.2 A at 110 V<br>0.2/0.1 A at 220 V |

**Table 5: Weights and dimensions**

|                  |   |
|------------------|---|
| Weight           |   |
| RARIC, version 1 | 4 kg  |
| RARIC, version 2 | 5 kg  |
| ILDD             | 10 + 80(D - 300) / 2300 kg<br>where D is the inner diameter in mm |
| Dimension        |   |
| RARIC, version 1 | 4U 24C  |
| RARIC, version 2 | 4U 36C  |
| ILDD             | See Fig. 4  |

## Diagrams

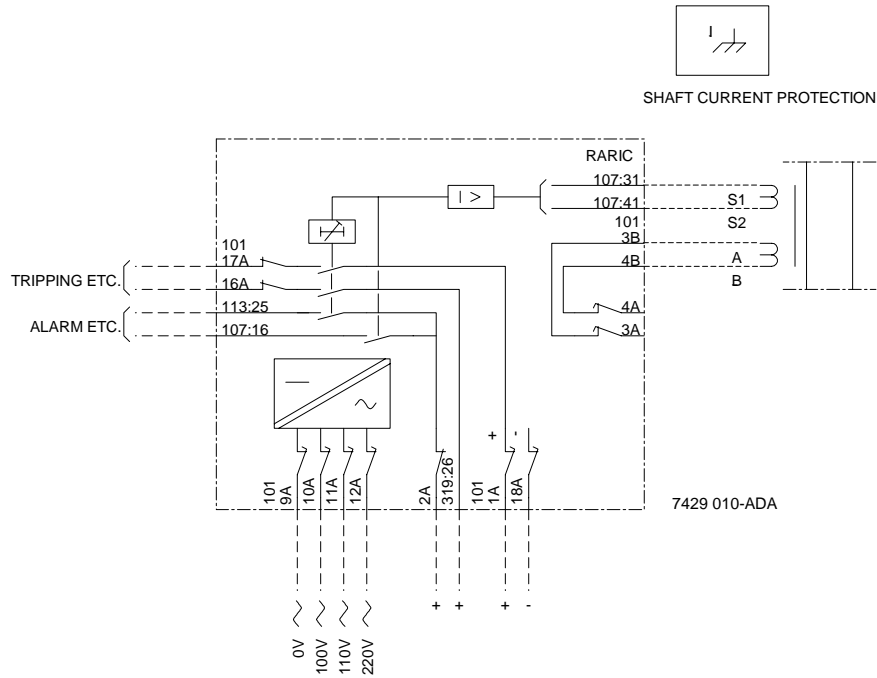

Fig. 1 Terminal diagram 7429 010-ADA for RARIC, RK 649 101-AD

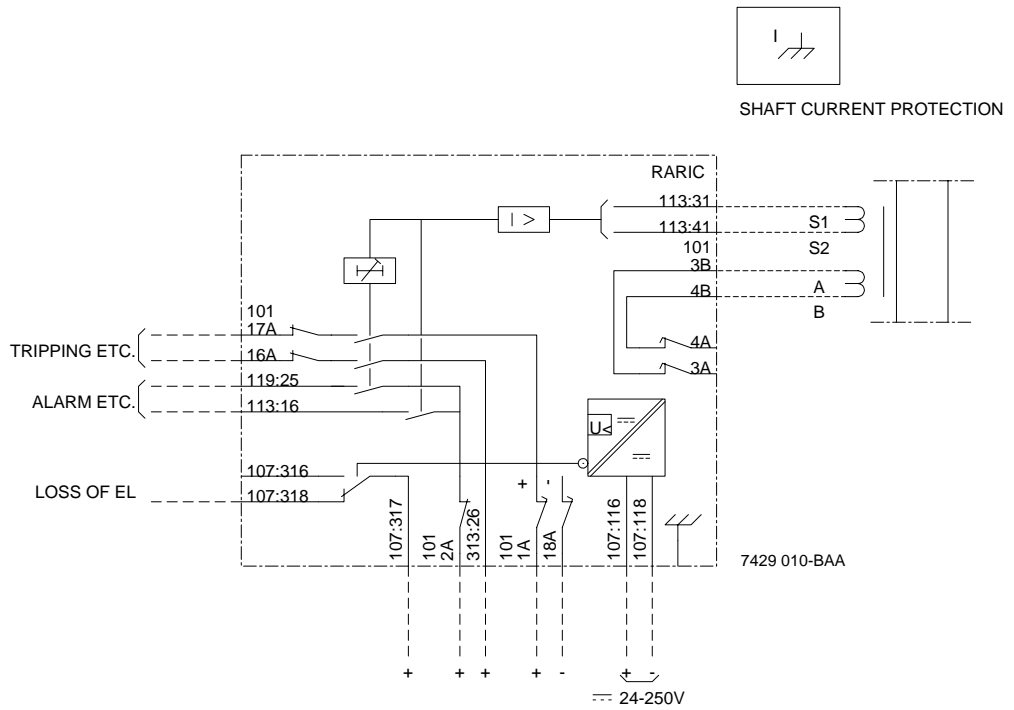

Fig. 2 Terminal diagram 7429 010-BAA for RARIC, RK 649 101-BA

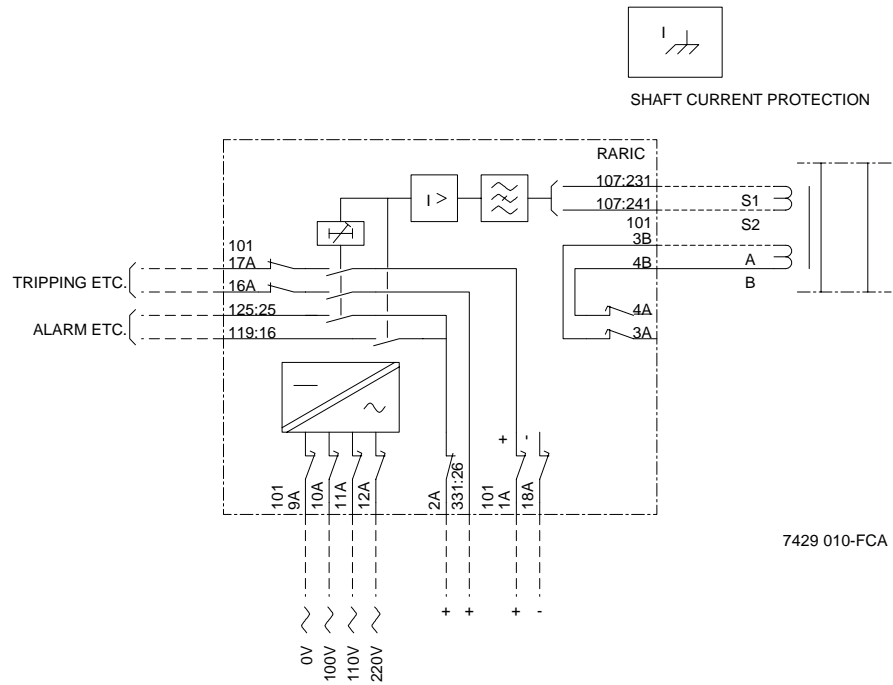

Fig. 3 Terminal diagram 7429 010-FCA for RARIC, RK 649 101-FC

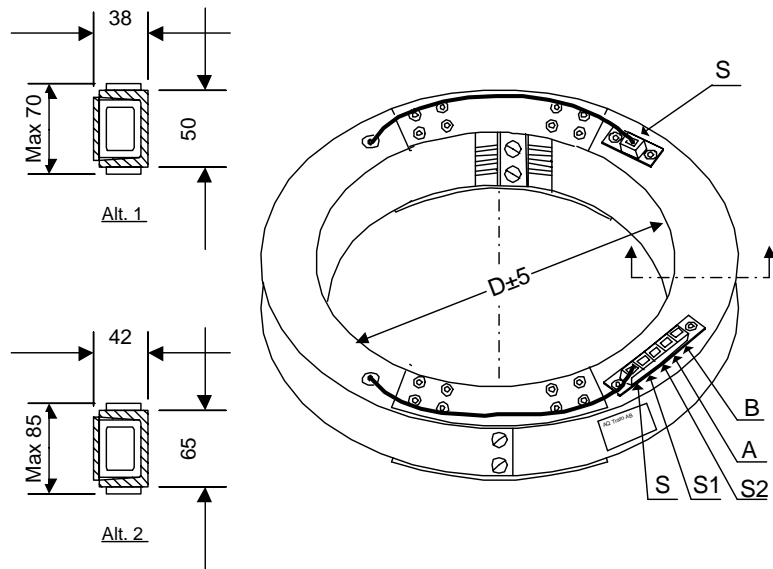

Fig. 4 Shaft current transformer ILDD dimensions in mm.

**Ordering**

Specify:

- **Shaft current protection RARIC**
- Ordering No.
  - Version 1, AC supply: RK 649 101-AD
  - Version 1, DC supply: RK 649 101-BA
  - Version 2, AC supply: RK 649 101-FC
- Quantity
- Desired wording on the lower half of the test switch face plate. Max. 13 lines with 14 characters per line

Mounting:

RARIC is provided on apparatus bars. When additional mounting is required, specify a 4U equipment frame for 19" rack mounting or a type RHGX 8, 12 or 20 case for panel mounting

• **Shaft current transformer ILDD**

- Ordering No. 1MRK 002 073-XXX  
where XXX is the inner diameter in cm from 16 to 300 cm in steps of 2 cm for diameters ≤ 140 cm and in steps of 4 cm for diameters > 140 cm

## • Quantity

Ordering No. ex.1: 1MRK 002 073-72 is an ILDD with 72 cm inner diameter

Ordering No. ex.2: 1MRK 002 073-244 is an ILDD with 244 cm inner diameter

**References**

|   |                  |
|---|------------------|
| Current relay RXIK 1                                | 1MRK 508 018-BEN |
| Time relay RXKL                                     | 1MRK 508 002-BEN |
| Auxiliary relay RXME 18                             | 1MRK 508 015-BEN |
| DC/DC-converter RXTUG 22H                           | 1MRK 513 001-BEN |
| AC/DC-converter RXTUB 2                             | 1MRK 513 004-BEN |
| Test system COMBITEST                               | 1MRK 512 001-BEN |
| Connection and installation components in COMBIFLEX | 1MRK 513 003-BEN |
| User's Guide RARIC                                  | 1MRK 502 001-UEN |

**Manufacturer**

**ABB Automation Technology Products AB**  
 Substation Automation  
 SE-721 59 Västerås  
 Sweden  
 Telephone: +46 (0) 21 34 20 00  
 Facsimile: +46 (0) 21 14 69 18  
 Internet: [www.abb.com/substationautomation](http://www.abb.com/substationautomation)