



(SE970120)

(SE970114)

Features

- Micro-processor based time-over/undervoltage relay with continuous settings for start and time functions
- Three variants, with wide setting ranges in two measuring stages:
 - Stage 1: $U1 = (0,5-1,0) \times U_s$
 - Stage 2: $U2 = (0,25-1,5) \times U_s$
 - $U_s = (0,2-1,6) \times U_r$
- The two measuring stages are switchable for over- or undervoltage function independently of each other
- Stage 1 is programmable for two time characteristics:
 - Inverse time
 - Definite time delay settable 50 ms-16,1 s
- Stage 2 can be delayed up to 10 s
- Reset ratio typical 96% for overvoltage function and 104% for undervoltage function enables a setting close to maximum service values
- Available with optional filters for different frequency characteristics:
 - 50-60 Hz, Sharp
 - 150-180 Hz, Sharp
 - 16 2/3 Hz, Flat

Application

RXEDK 2H is a time-over/undervoltage relay with two measuring stages, which are switchable for over- or undervoltage functions independently of each other. Stage 1 is programmable for the following two different time functions:

- Definite-time characteristic – where the operate time is independent of the voltage deviation. The definite-time is settable from 50 ms to 16,1 s.
- Inverse time characteristic – where the operate time is dependent of the voltage deviation from the set value (see Fig. 1). The relationship between time and voltage for this characteristic can be expressed as follows:

Overvoltage function:
standard

$$t = \frac{k}{\left(\frac{U}{U_1} - 1\right)} \text{ [s]}$$

16 2/3 Hz
alternative version

$$t = \frac{k}{\left(\left(\frac{U}{U_1}\right)^{0,5} - 1\right)}$$

Undervoltage function:
standard

$$t = \frac{k}{1 - \frac{U}{U_1}} \text{ [s]}$$

16 2/3 Hz
alternative version

$$t = \frac{k}{\left(1 - \left(\frac{U}{U_1}\right)^{0,5}\right)}$$

where
k = inverse time constant
U1 = over/undervoltage start value
U = operate value

Time characteristics is independent to the settable value. The delay time is settable between 50 ms and 16,1 s.

Stage 2 has a definite-time characteristic, and is settable from 30 ms to 10 s.

The time-over/undervoltage relays of type RXEDK 2H can be used in a number of different applications such as:

Neutral point voltage protection

Time delayed single-phase relay is used to detect occurrence of an earth fault in a network by detecting neutral point voltage on an open delta winding of phase transformers or on a neutral transformer. The start step can be used to release selective earth fault current protection.

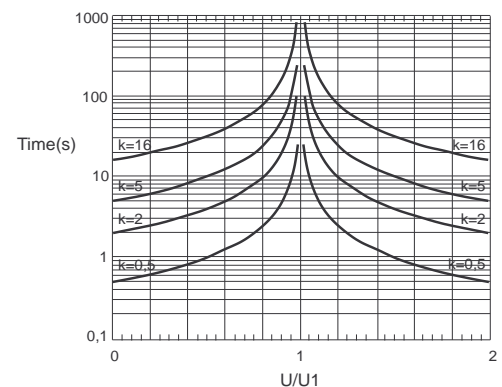

(96000260)

Fig. 1 Inverse time characteristic.

Overvoltage protection

For generator protection an overvoltage relay is used to detect failure in voltage regulation. For transformers and transmission lines, overvoltage protection is sometimes used to detect excessive voltages. For these applications the high reset ratio is essential.

Flash-over protection

For transformer low voltage windings an instantaneous protection will detect the high overvoltages occurring at a flash-over from the high to low voltage side of transformers where the low voltage side is not solidly earthed.

Undervoltage protection

An undervoltage protection is used to disconnect motors at low system voltage to prevent problems with inrush at system voltage recovery. Single-phase versions connected phase-phase are used for asynchronous motors, whereas measuring of positive sequence voltage is used for synchronous motors.

Stator earth fault protection

With optimal filters for measuring either fundamental overvoltage or third harmonic undervoltage.

Design

The voltage relay assemblies with RXEDK 2H can be delivered in several variants for single- and three-phase over- or undervoltage protection with different output circuits.

All assemblies are with test switch RTXP 18, for simple secondary testing, and with trip indication either with LED or flag relay.

The RXEDK 2H relay requires a separate dc-dc converter for auxiliary supply (± 24 V). One RXTUG converter can supply up to nine relays.

Note:

When RXEDK 2H relay or the dc-dc converter RXTUG is plugged into or withdrawn from a terminal base, the auxiliary voltage supply must be interrupted. Neither is it allowed to open wiring on plus or minus supply with unit in service.

RXEDK 2H measuring relay

The over/undervoltage relay, type RXEDK 2H, is a static microprocessor based relay with two delayed stages. The relay consists mainly of an input voltage transformer, filter circuits, microprocessor, HMI, LEDs for start and trip indications and three output units which provide separate change-over contacts for start and trip of stage 1, and trip of stage 2. The relay has also one binary input for reset LED.

Operate values for both stage 1 and 2, are set with the potentiometers and programming switches marked with U_s . Both measuring stages can independently be programmed for over- or undervoltage functions. Operation occurs for a voltage equal to or larger/lower than the product of set scale value and the selected scale constant.

The start function output is energized immediately after the measured value exceeds or falls below the set start voltage level.

Stage 1 can be set for definite-time or inverse-time delay, while stage 2 only has definite time delay.

For definite-time delayed operation the time voltage output operates after the set time delay.

For inverse-time operation, the operate time will depend on the time setting (constant $k +$ setting of programming switches), and by how much the measured voltage magnitude exceeds or falls below the start voltage level setting (see Fig. 1 for operation characteristic).

The relay can be supplied with optional filters for sharp measuring of fundamental frequencies (50-60 Hz) or third harmonics (150-180 Hz). The characteristics of the filters are shown in Fig. 2.

Technical data

Table 1: Voltage input

Rated voltage U_r	2/5 V or 20/50 V or 100/200 V, For 16 2/3 Hz: 2/5 V or 20/50 V, For 16 2/3 Hz: alternative version 20/50 V	
Scale constant U_s	$(0,2-1,6) \times U_r$ (in steps of 0,2)	
Setting ranges		
Stage U1		
2/5 V	0,2-3,2 V/0,5-8 V	
20/50 V	2-32 V/5-80 V	
100/200 V	10-160 V/20-320 V	
Stage U2		
2/5 V	0,1-4,8 V/0,25-12V	
20/50 V	1-48 V/2,5-120 V	
100/200 V	5-240 V/10-480 V	
Effective voltage range U	$(0,25-2,0) \times U_s$	
Rated frequency f_r	50-60 Hz Filter opt.: 50-60 Hz, flat std (see Fig. 2) 50-60 Hz, sharp (see Fig. 3) 150-180 Hz, sharp (see Fig. 4)	16 2/3Hz (see Fig. 5)
Frequency range	40-1000 Hz	15-150 Hz
Power consumption		
U = lowest U_s	2 mVA	
U = highest U_s	210 mVA	
Overload capacity		
continuously	3,5 x U_r (Max. 500 V AC for COMBIFLEX)	
during 10 s	4,0 x U_r (Max. 500 V AC for COMBIFLEX)	

Table 2: Start and trip functions for standard, 50 Hz sharp and 150-180 Hz sharp

Voltage function	Stage U1	Stage U2
Scale range	$(0,5-1,0) \times U_s$	$(0,25-1,5) \times U_s$
Measuring mode	Over/Under voltage	
Operate time	Start function	t = 0,03 s
Over-voltage (typical)		
U = 0 => 1,1 x op. value	45 ms	45 ms
U = 0 => 1,5 x op. value	40 ms	40 ms
U = 0,9 => 1,1 x op. value	35 ms	35 ms
U = 0,9 => 1,5 x op. value	30 ms	30 ms
U = 0,9 => 2,0 x op. value	25 ms	25 ms
Under-voltage (typical)		
U = 1,1 => 0,9 x op. value	35 ms	35 ms
U = 1,1 => 0,5 x op. value	30 ms	30 ms
U = 1,1 => 0 x op. value	25 ms	25 ms
Reset time, Over-voltage (typical)	Start function	t = 0,03 s
U = 1,5 => 0,9 x op. value	35 ms	35 ms
U = 1,5 => 0 x op. value	45 ms	45 ms
Consistency of the operate value	< 0,5%	
Reset ratio over/under	> 95% / <105%	
Recovery time	< 50 ms	
Overshoot time	< 25 ms	

Table 2: Start and trip functions for standard, 50 Hz sharp and 150-180 Hz sharp

Voltage function	Stage U1	Stage U2
Frequency dependence within frequency range 50 Hz, $\pm 5\%$ frequency range 60 Hz, $\pm 5\%$	< 0,5% < 1,0%	
Operate value at 150 Hz	App. 1,45 x op. value at 50 Hz	
Influence of harmonics 100 / 120 Hz, 5% 150 / 180 Hz, 20% 250 / 300 Hz, 20%	< 2% < 6% < 3%	

Table 3: Time functions for standard, 50 Hz sharp and 150-180 Hz sharp

Time function	Stage U1	Stage U2
Time delay	Definite time and inverse time	Definite time
Setting range Definite time, Def. time Inverse time, Inv Formula for inverse time Overvoltage function Undervoltage function	t = 0,05-16,1 s k = 0,05-16,1 t = k / (a - 1) t = k / (1 - a) k = Inverse time factor a = Over / under-voltage times operate value	0,03-10 s –
Accuracy Definite time Inverse time	1% and ± 10 ms 1% of the over/under-voltage and ± 10 ms or 3% of the operate time and ± 30 ms	1% and ± 10 ms –
Consistency	< 0,5%	< 0,5%

Table 4: Filter option, deviation from technical data for RXEDK 2H, standard

	Filter options	
	50-60 Hz, sharp	150-180 Hz, sharp
Operate time for start function over-voltage (typical) U = 0 => 1,1 x op. value U = 0 => 1,5 x op. value	90 ms 70 ms	65 ms 50 ms
Reset ratio for over-voltage	> 95%	
Recovery time	< 50 ms	< 50 ms
Overshoot time	< 35 ms	< 30 ms
Frequency dependence within frequency range $\pm 5\%$	< 15%	< 15%
Influence of harmonics 50, 60 Hz, 100% 100, 120 Hz, 100% 150, 180 Hz, 100% 250, 300 Hz, 100%	– < 3% < 3% < 1%	< 1% < 2% – < 2%

Technical data (cont'd)

Table 5: Start and trip functions 16 2/3 Hz

Voltage function	Stage U1	Stage U2
Scale range	$(0,5-1,0) \times U_s$	$(0,25-1,5) \times U_s$
Measuring mode	Over/Under voltage	
Operate time	Start function	t = 0,08 s
Over-voltage (typical)		
U = 0,9 => 1,1 x op. value	75 ms	75 ms
U = 0,9 => 1,5 x op. value	55 ms	55 ms
U = 0,9 => 2,0 x op. value	50 ms	50 ms
Under-voltage (typical)		
U = 1,1 => 0,9 x op. value	75 ms	75 ms
U = 1,1 => 0,5 x op. value	55 ms	55 ms
U = 1,1 => 0 x op. value	50 ms	50 ms
Reset time, Over-voltage (typical)	Start function	t = 0,08 s
U = 1,1 => 0,9 x op. value	85 ms	85 ms
U = 1,1 => 0,5 x op. value	60 ms	60 ms
U = 1,1 => 0 x op. value	50 ms	50 ms
Consistency of the op. value	< 1,0%	
Reset ratio Over/Under	> 95% / < 105%	
Recovery time over-voltage		
U = 1,1 => 0 x op. value	< 60 ms	
U = 2,0 => 0 x op. value	< 90 ms	
Overshoot time	< 60 ms	
Frequency dependence within frequency range 15,00-18,33 Hz	< 2,0%	
Influence of harmonics		
33 1/3 Hz, 5%	< 2%	
50 Hz, 20%	< 5%	
83 1/3 Hz, 20%	< 3%	

Table 6: Time functions 16 2/3 Hz

Time function	Stage U1	Stage U2
Time delay	Definite time and inverse time	Definite time
Setting range		
Definite time, Def. time	t = 0,05-16,1 s	0,08-10 s
Inverse time, Inv	k = 0,05-16,1	-
Formula for inverse time		
Overvoltage function	$t = k / (a - 1)$ *) $t = k / (a^{0,5} - 1)$	
Undervoltage function	$t = k / (1 - a)$ *) $t = k / (1 - a^{0,5})$	
	k = Inverse time factor	
	a = Over / under-voltage times operate value	
	*) 16 2/3 Hz alternative version	
Accuracy		
Definite time	1% and ±30 ms	1% and ±30 ms
Inverse time	1% of the over/under-voltage and ±30 ms or 3% of the operate time and ±60 ms	-
Consistency	< 0,5%	< 0,5%

Table 7: Auxiliary DC voltage supply

Auxiliary voltage EL for RXTUG 22H Auxiliary voltage to the relay	24-250 V DC, $\pm 20\%$ ± 24 V (from RXTUG 22H)	
Power consumption at RXTUG 22H input 24-250 V before operation after operation without RXTUG 22H ± 24 V before operation after operation	Standard Max. 4,5 W Max. 6,0 W Max. 1,3 W Max. 3,0 W	Other filters Max. 5,5 W Max. 6,5 W Max. 2,0 W Max. 3,0 W

Table 8: Binary input

Binary input voltage RL	48-60 V and 110-220 V DC, -20% to +10%
Power consumption 48-60 V 110-220 V	Max. 0,3 W Max. 1,5 W

Table 9: Output relays

Contacts	3 change-over
Maximum system voltage	250 V AC / DC.
Current carrying capacity continuous during 1 s	5 A 15 A
Making capacity at inductive load with L/R >10 ms during 200 ms during 1 s	30 A 10 A
Breaking capacity AC, max. 250 V, $\cos \varphi > 0,4$ DC, with L/R < 40 ms 48 V 110 V 220 V 250 V	8 A 1 A 0,4 A 0,2 A 0,15 A

Table 10: Electromagnetic compatibility (EMC), immunity tests

All tests are done together with the DC/DC-converter, RXTUG 22H

Test	Severity	Standard
Surge	1 and 2 kV, normal service 2 and 4 kV, destructive test	IEC 61000-4-5, class 3 IEC 61000-4-5, class 4
AC injection	500 V, AC	SS 436 15 03, PL 4
Power frequency magnetic field	1000 A/m	IEC 61000-4-8
1 MHz burst	2,5 kV	IEC 60255-22-1, class 3
Spark	4-8 kV	SS 436 15 03, PL 4
Fast transient	4 kV	IEC 60255-22-4, class 4
Electrostatic discharge In normal service with cover on	8 kV (contact) 15 kV (air) 8 kV, indirect application	IEC 60255-22-2, class 4 IEC 60255-22-2, class 4 IEC 61000-4-2, class 4
Radiated electromagnetic field	10 V/m, 26-1000 MHz	IEC 61000-4-3, level 3
Conducted electromagnetic	10 V, 0,15-80 MHz	IEC 61000-4-6, level 3
Interruptions in auxiliary voltage 110 V DC, no resetting for interruptions	2-200 ms < 40 ms	IEC 60255-11

Technical data (cont'd)

Table 11: Electromagnetic compatibility (EMC), emission tests

Test	Severity	Standard
Conducted	0,15-30 MHz, class A	EN 50081- 2
Radiated	30-1000 MHz, class A	EN 50081- 2

Table 12: Insulation tests

Test	Severity	Standard
Dielectric Circuit to circuit and circuit to earth Over open contact	2,0 kV AC, 1 min 1,0 kV AC, 1 min	IEC 60255-5
Impulse voltage	5 kV, 1,2/50 μ s, 0,5 J	IEC 60255-5
Insulation resistance	> 100 M Ω at 500 V DC	IEC 60255-5

Table 13: Mechanical tests

Test	Severity	Standard
Vibration	Response: 2,0 g, 10-150-10 Hz Endurance: 1,0 g, 10-150-10 Hz, 20 sweeps	IEC 60255-21-1, class 2 IEC 60255-21-1, class 1
Shock	Response: 5 g, 11 ms, 3 pulses Withstand: 15 g, 11 ms, 3 pulses	IEC 60255-21-2, class 1
Bump	Withstand: 10 g, 16 ms, 1000 pulses	IEC 60255-21-2, class 1
Seismic	X axis: 3,0 g, 1-35-1 Hz Y axis: 3,0 g, 1-35-1 Hz Z axis: 2,0 g, 1-35-1 Hz	IEC 60255-21-3, class 2 extended (Method A)

Table 14: Temperature range

Storage	-20 °C to +70 °C
Permitted ambient temperature	-5 °C to +55 °C

Table 15: Weight and dimensions

Equipment	Weight	Height	Width
RXEDK 2H without RXTUG 22H	0,7 kg	4U	6C

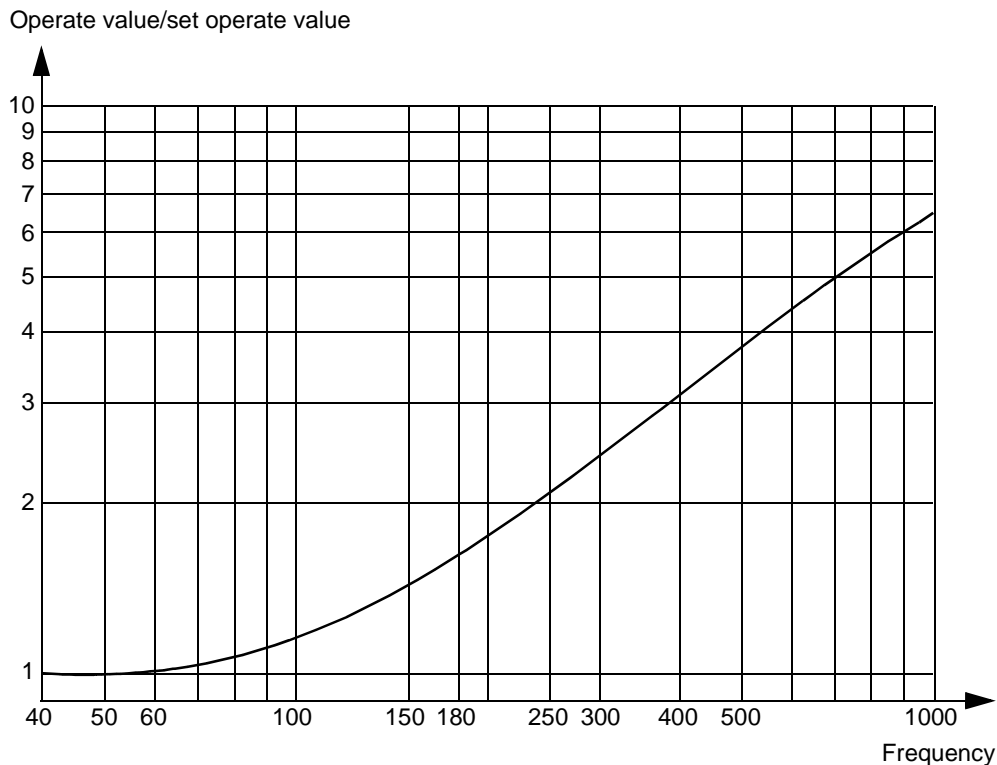

Fig. 2 Typical frequency characteristic for RXEDK 50-60 Hz, standard, valid for $U \leq 2,0 \times U_s$.

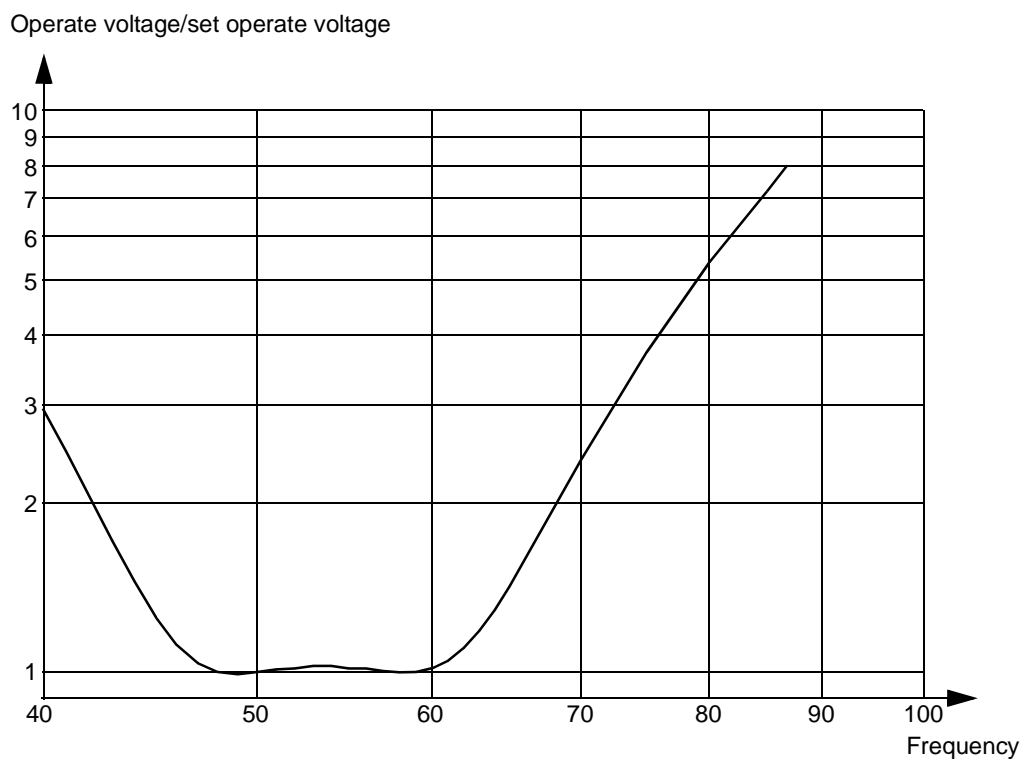

Fig. 3 Typical frequency characteristic for RXEDK 50-60 Hz, sharp, valid for $U \leq 2,0 \times U_s$.

Technical data (cont'd)

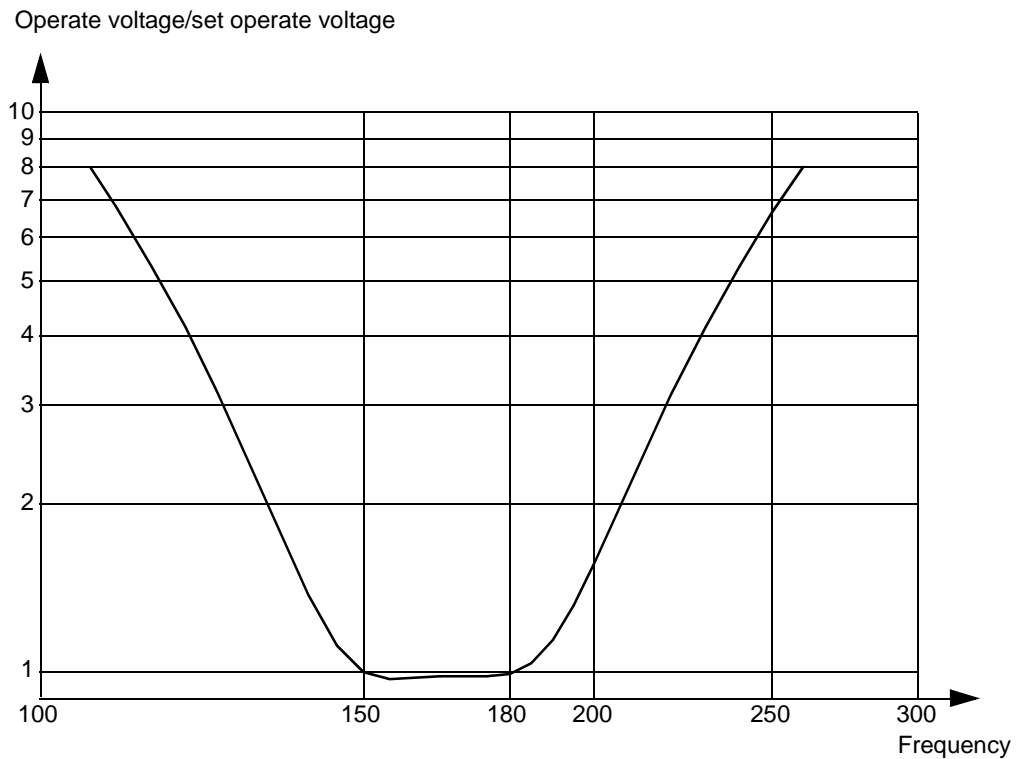

Fig. 4 Typical frequency characteristic for RXEDK 150-180 Hz, sharp, valid for $U \leq 2,0 \times U_s$.

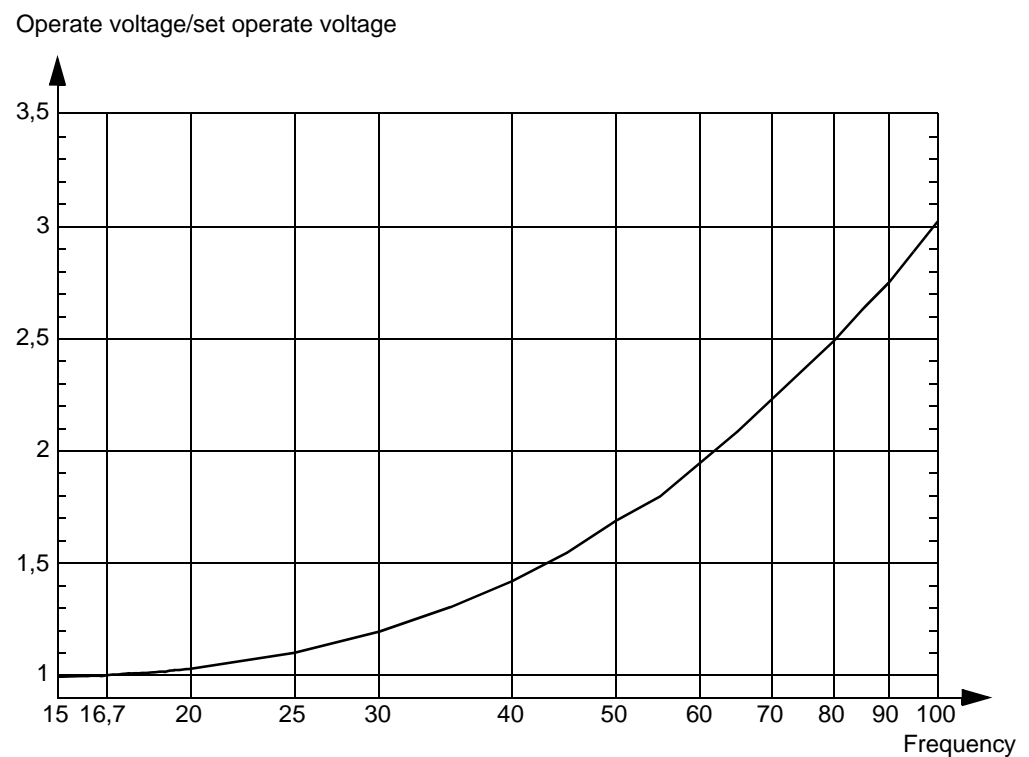

Fig. 5 Typical frequency characteristic for RXEDK 16 2/3 Hz, flat, valid for $U \leq 2,0 \times U_s$.

Diagrams

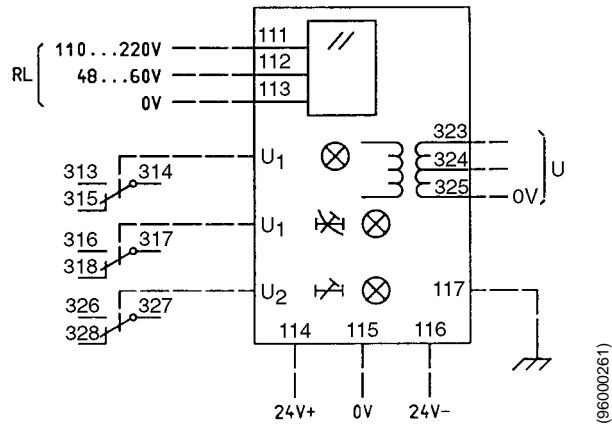

Fig. 6 Terminal diagram RXEDK 2H.

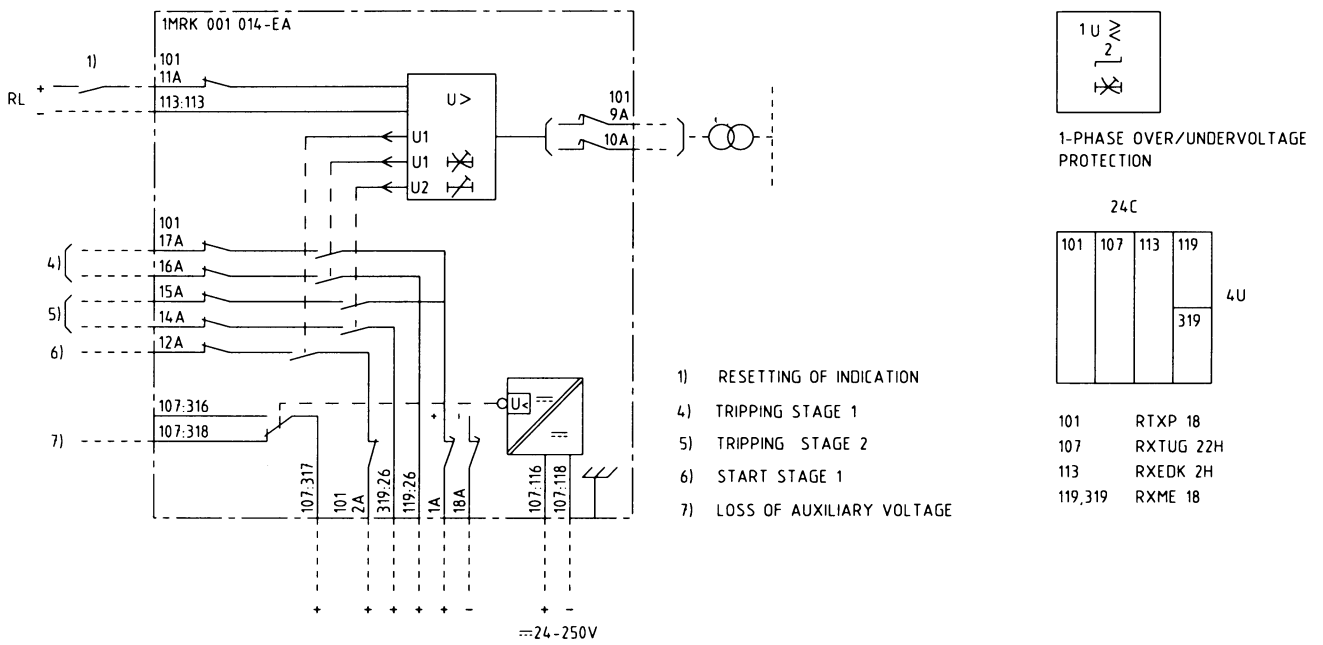

Fig. 7 Terminal diagram 1MRK 001 014-EAA

Diagrams (cont'd)

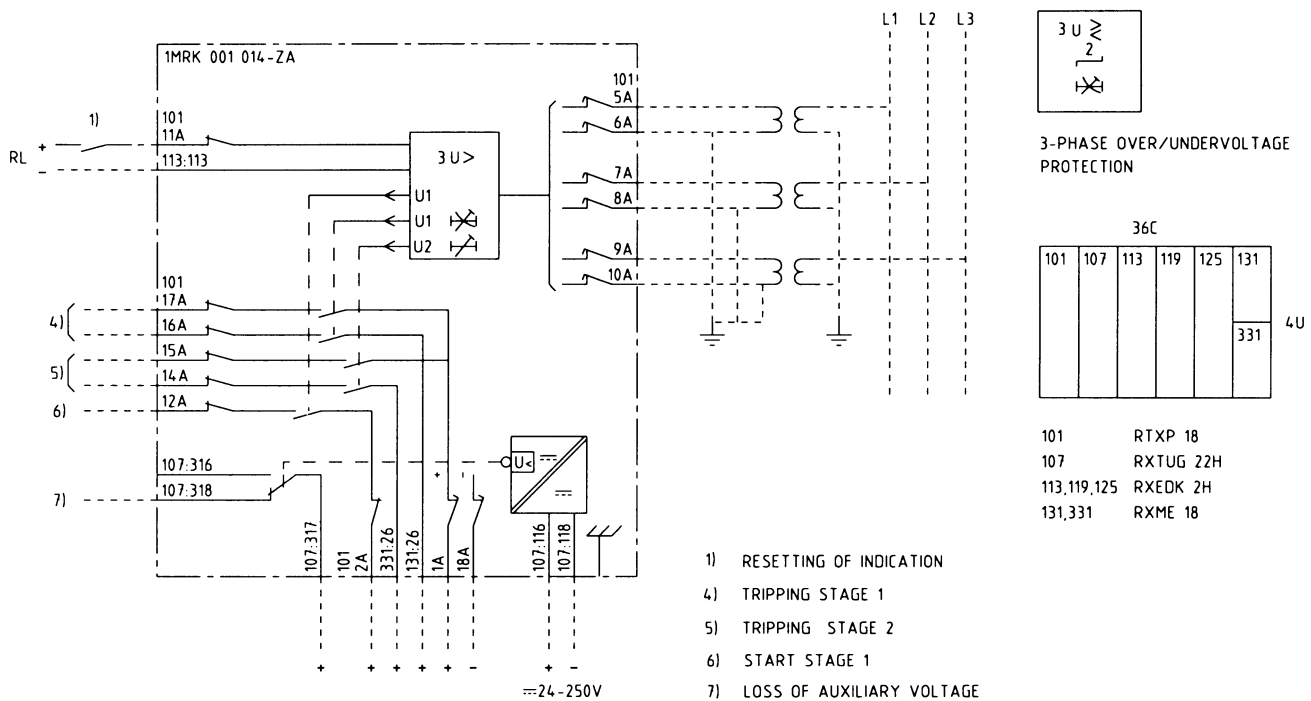

Fig. 8 Terminal diagram 1MRK 001 014-ZAA

Protection assemblies

RAEDK

Protection assemblies are built up based upon time voltage relay RXEDK 2H. Test device RXP 18 and dc/dc-converter RXTUG 22H can also be included for specific application requirements. Test device RXP 18 is a tool for relay testing.

DC/DC-converter RXTUG 22H can be used either separately for a single protection or to feed also other protections with up to 9 units of the same relay family. With RXTUG 22H all requirements concerning disturbance emission and immunity with this protection assembly will be met.

The assemblies have output contacts as specified for the relay RXEDK 2H, which in most cases are fully sufficient. Protections are

normally available with output logic with heavy duty relay RXME 18 (RK 221 825-XX) with indicating flag and can upon request be completed with an output logic of free choice. Output relays are connected to separate auxiliary voltage.

The extremely flexible mounting system COMBIFLEX together with a modern CAD-system enables us to present a unique flexibility for designing assemblies upon the customers requests.

The interface voltage for enable or block impulses can be connected to either 48-60 V dc or 110-220 V dc by connecting the voltage circuit to separate terminals. At delivery all relays are connected for 110-220 V dc.

RAEDK 1 Single-phase voltage protection

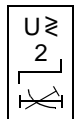
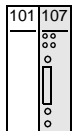
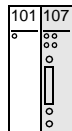
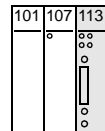
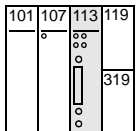
 <p>27,59</p> <p>[1=>0]</p>				
	101 RTXP 18 107 RXEDK 2H	101 RXTUG 22H 107 RXEDK 2H	101 RTXP 18 107 RXTUG 22H 113 RXEDK 2H	101 RTXP 18 107 RXTUG 22H 113 RXEDK 2H 119 RXME 18 319 RXME 18
	Order No. Circuit diagram	Order No. Circuit diagram	Order No. Circuit diagram	Order No. Circuit diagram
Standard	1MRK 001 013-BS 1MRK 001 014-BA	1MRK 001 013-CS 1MRK 001 014-CA	1MRK 001 013-DS 1MRK 001 014-DA	1MRK 001 013-ET 1MRK 001 014-EA
Filter	1MRK 001 013-BA 1MRK 001 014-BA	1MRK 001 013-CA 1MRK 001 014-CA	1MRK 001 013-DA 1MRK 001 014-DA	1MRK 001 013-EA 1MRK 001 014-EA

RAEDK 2 Two-phase voltage protection

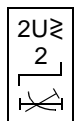
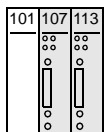
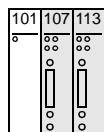
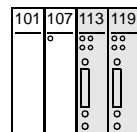
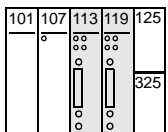
 <p>27,59</p> <p>[1=>0]</p>				
	101 RTXP 18 107 RXEDK 2H 113 RXEDK 2H	101 RXTUG 22H 107 RXEDK 2H 113 RXEDK 2H	101 RTXP 18 107 RXTUG 22H 113 RXEDK 2H 119 RXEDK 2H	101 RTXP 18 107 RXTUG 22H 113 RXEDK 2H 119 RXEDK 2H 125 RXME 18 325 RXME 18
	Order No. Circuit diagram	Order No. Circuit diagram	Order No. Circuit diagram	Order No. Circuit diagram
Standard	1MRK 001 013-GS 1MRK 001 014-GA	1MRK 001 013-HS 1MRK 001 014-HA	1MRK 001 013-KS 1MRK 001 014-KA	1MRK 001 013-LS 1MRK 001 014-LA
Filter	1MRK 001 013-GA 1MRK 001 014-GA	1MRK 001 013-HA 1MRK 001 014-HA	1MRK 001 013-KA 1MRK 001 014-KA	1MRK 001 013-LA 1MRK 001 014-LA

Protection assemblies (cont'd)

RAEDK 3 Three-phase voltage protection

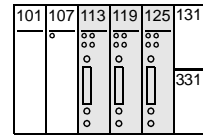
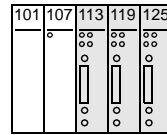
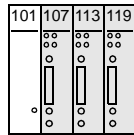
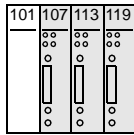
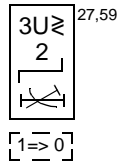

101 RTXP 18
107 RXEDK 2H
113 RXEDK 2H
119 RXEDK 2H

101 RXTUG 22H
107 RXEDK 2H
113 RXEDK 2H
119 RXEDK 2H

101 RTXP 18
107 RXTUG 22H
113 RXEDK 2H
119 RXEDK 2H
125 RXEDK 2H

101 RTXP 18
107 RXTUG 22H
113 RXEDK 2H
119 RXEDK 2H
125 RXEDK 2H
131 RXME 18
331 RXME 18

Order No. Circuit diagram

Order No. Circuit diagram

Order No. Circuit diagram

Order No. Circuit diagram

Standard

1MRK 001 013-NS 1MRK 001 014-NA

1MRK 001 013-YS 1MRK 001 014-YA

1MRK 001 013-PS 1MRK 001 014-PA

1MRK 001 013-ZS 1MRK 001 014-ZA

Filter

1MRK 001 013-NA 1MRK 001 014-NA

1MRK 001 013-YA 1MRK 001 014-YA

1MRK 001 013-PA 1MRK 001 014-PA

1MRK 001 013-ZA 1MRK 001 014-ZA

Mounting alternatives

All assemblies can be delivered in the following mounting alternatives:

- on apparatus bars
- in equipment frame 60C
- in RHGX
- in RHGS

Ordering

Specify RAEDK (Protection):

- Quantity
- Ordering number
- Code U, H, M
- Desired wording on the lower half of the test switch face plate max. 13 lines with 14 characters per line.

Specify RXEDK (Loose Relay):

- Quantity
- Ordering number

Over/undervoltage relay, standard 50-60 Hz

Type	Voltage	Filter	Article No.	Code
RXEDK 2H	2/5 V	50-60 Hz (standard)	1MRK 000 841-AA	<input type="checkbox"/> U1
RXEDK 2H	20/50 V	50-60 Hz (standard)	1MRK 000 841-HA	<input type="checkbox"/> U5
RXEDK 2H	100/200 V	50-60 Hz (standard)	1MRK 000 841-RA	<input type="checkbox"/> U9

Over/undervoltage relay; with optional filters

Type	Voltage	Filter	Article No.	Code
RXEDK 2H	2/5 V	50-60 Hz (sharp)	1MRK 000 841-BA	<input type="checkbox"/> U2
RXEDK 2H	2/5 V	150-180 Hz (sharp)	1MRK 000 841-CA	<input type="checkbox"/> U3
RXEDK 2H	2/5 V	16 ² / ₃ Hz (flat)	1MRK 000 841-EA	<input type="checkbox"/> U4
RXEDK 2H	20/50 V	50-60 Hz (sharp)	1MRK 000 841-KA	<input type="checkbox"/> U6
RXEDK 2H	20/50 V	150-180 Hz (sharp)	1MRK 000 841-LA	<input type="checkbox"/> U7
RXEDK 2H	20/50 V	16 ² / ₃ Hz (flat)	1MRK 000 841-NA	<input type="checkbox"/> U8
RXEDK 2H	100/200 V	50-60 Hz (sharp)	1MRK 000 841-SA	<input type="checkbox"/> U10
RXEDK 2H	100/200 V	150-180 Hz (sharp)	1MRK 000 841-TA	<input type="checkbox"/> U11
RXEDK 2H	20/50 V	16 ² / ₃ Hz (alternative version)	1MRK 000 841-PA	<input type="checkbox"/> U12

Auxiliary voltage

For included auxiliary relays

	Code
24 V dc	<input type="checkbox"/> H5
48-55 V dc	<input type="checkbox"/> H6
110-125 V dc	<input type="checkbox"/> H7
220-250 V dc	<input type="checkbox"/> H8

Mounting

Mounting alternatives	Size	Article No.	Code
Apparatus bars			<input type="checkbox"/> M10
Equipment frame without door	4U 19"	1MRK 000 137-GA	<input type="checkbox"/> M11
Equipment frame with door	4U 19"	1MRK 000 137-KA	<input type="checkbox"/> M12
RHGX 4	4U 12C	RK 927 001-AB	<input type="checkbox"/> M71
RHGX 8	4U 24C	RK 927 002-AB	<input type="checkbox"/> M72
RHGX 12	4U 36C	RK 927 003-AB	<input type="checkbox"/> M73
RHGX 20	4U 60C	RK 927 004-AB	<input type="checkbox"/> M74
RHGS 30	6U x 1/1 19" rack	1MRK 000 315-A	<input type="checkbox"/> M81
RHGS 12	6U x 1/2 19" rack	1MRK 000 315-B	<input type="checkbox"/> M82
RHGS 6	6U x 1/4 19" rack	1MRK 000 315-C	<input type="checkbox"/> M83

References

Connection and installation components in COMBIFLEX	1MRK 513 003-BEN
Relay accessories COMBIFLEX	1MRK 513 004-BEN
User's Guide RXEDK	1MRK 508 008-UEN

Manufacturer

ABB Automation Technology Products AB
Substation Automation
SE-721 59 Västerås
Sweden
Telephone: +46 (0) 21 34 20 00
Facsimile: +46 (0) 21 14 69 18
www.abb.com/substationautomation

