



## CPO 01 Cabinet Power Supply

### Contents:

1	Features .....	2
2	Application .....	2
3	Description .....	3
4	Operation and Signals .....	3
5	Connection Methods .....	5
6	Equipping Levels .....	8
7	Technical Data .....	9
7.1	Technical Data for the CPO 01 .....	9
7.2	Technical Data CS 400 / CS 410 .....	10
7.3	Technical Data for the CS 445 .....	11
8	Ordering information .....	12

# 1 Features

## Appearance may differ from picture

- Single or redundant single-phase AC supply
- Single or redundant DC supply
- Redundant supply from multiple mains networks
- Parallel feed for increased power capacity
- Automatic load distribution between power supply modules



# 2 Application

24 V DC power supply for devices fitted into 19" cabinets.

### 3 Description

The CPO 01 Cabinet Power Supply feeds 24 V DC to components built into 19" cabinets, such as the Maestro UX process control system. The modular structure with insertion slots allows requirements

- from the supply network
- on availability
- on electrical current requirements
- on the monitoring and signalling of operating and fault conditions

to be individually satisfied.

Up to 3 plug-in power supply units (type CS400, CS 410) can be operated in the CPO 01 Cabinet Power Supply. They may be operated singly, or more than one may be operated in parallel or redundantly (depending on the number and supply of the modules). Any desired combination of various power supply unit types is also possible here.

On the input side, the CPO 01 Cabinet Power Supply mains units have wide-range inputs for DC and for AC. At the output, 8 fused and monitored main circuits (F1 to F8) are available, together with a fused auxiliary circuit (F9).

Further monitoring and control functions are implemented in the CS 445 monitoring module which is integrated into the CPO 01 Cabinet Power Supply.

### 4 Operation and Signals

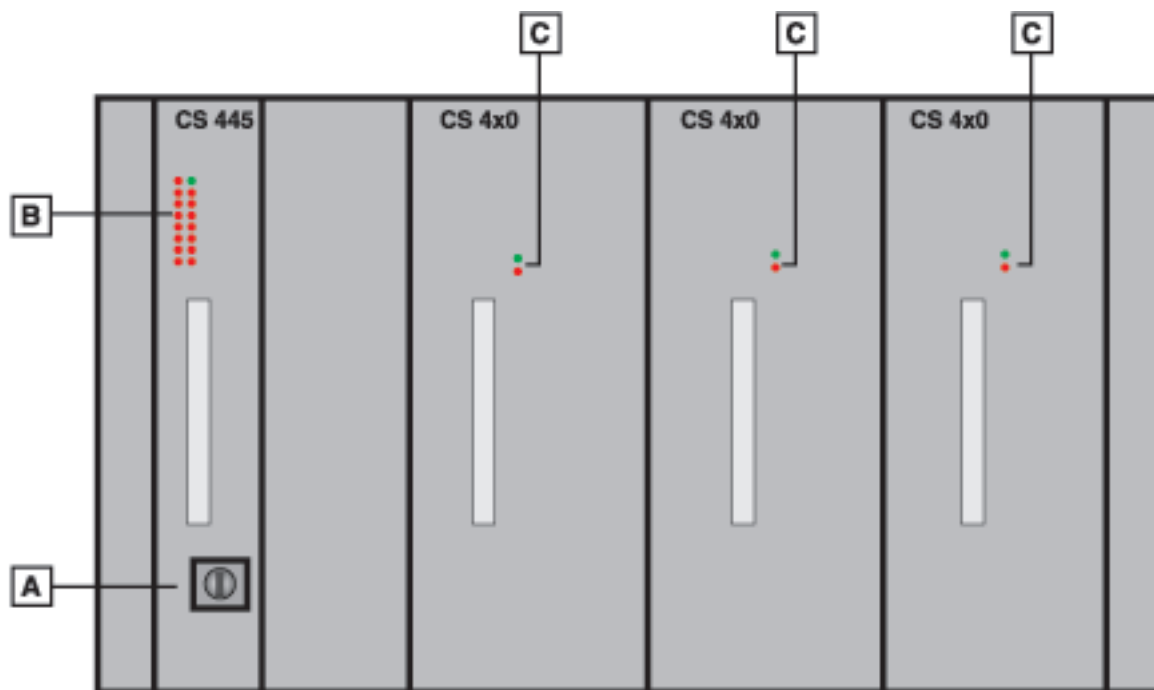

CPO 01 front view

A	Switch with which the outputs F1 to F9 can be electrically isolated. (Input RCI on plug X10 operates in parallel with this.)		
B	LED display on the CS 445		
	CF1 (red)	LED display on CS 4x0 Power (green) LED on=input voltage (AC or DC) present Error (red) LED on=Fault / error (including when supply voltage present and switch A is "OFF")	
	F2 (red)		
			LED on=F1 fuse triggered
			LED on=F2 fuse triggered
	F3 (red)	LED on=F3 fuse triggered	
	F4 (red)	LED on=F4 fuse triggered	
	F5 (red)	LED on=F5 fuse triggered	
	F6 (red)	LED on=F6 fuse triggered	
	F7 (red)	LED on=F7 fuse triggered	
	F8 (red)	LED on=F8 fuse triggered	
	Power (green)	LED on=CS 445 power (auxiliary power circuit) OK	
	A1 (red)	LED on=input ALARM-IN-1 contact closed (fault)	
	A2 (red)	LED on=input ALARM-IN-2 contact closed (fault)	
	A3 (red)	LED on=input ALARM-IN-3 contact closed (fault)	
A4 (red)	LED on=input ALARM-IN-4 contact closed (fault)		
S1 (red)	LED on=Fault on power unit inserted in position 1		
S2 (red)	LED on=Fault on power unit inserted in position 2		
S3 (red)	LED on=Fault on power unit inserted in position 3		

## 5 Connection Methods

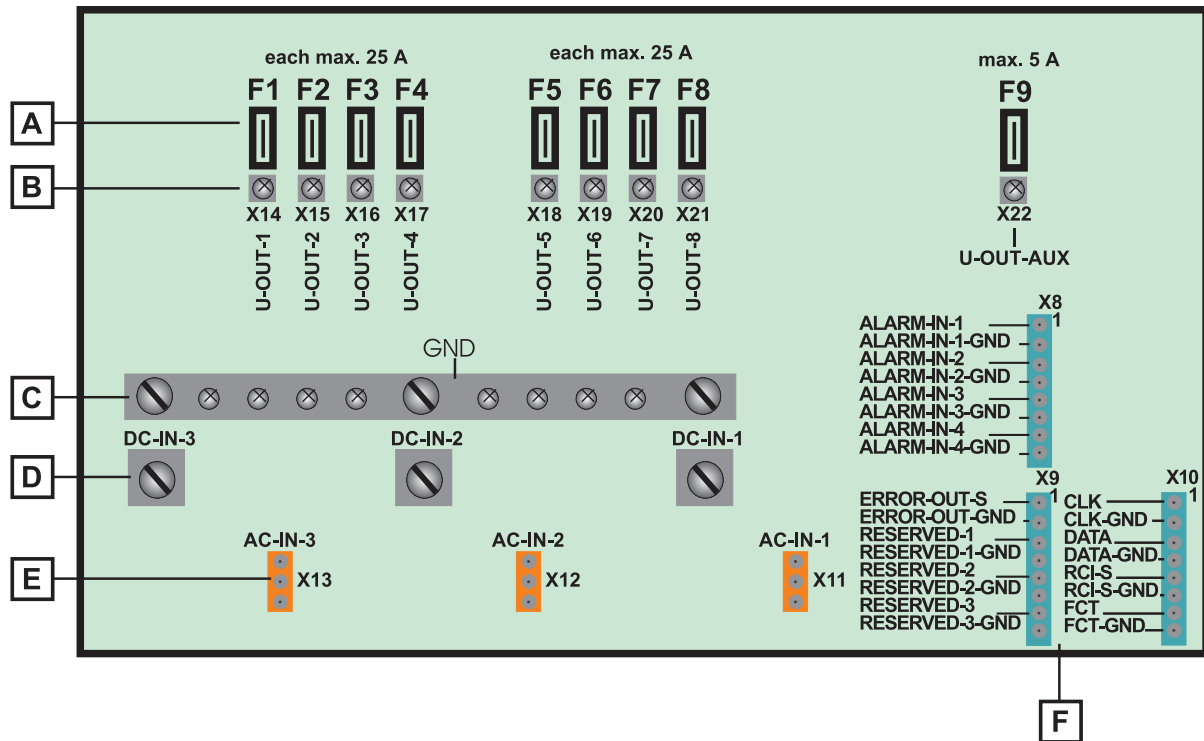

A	Fuse	
	F1 - F8	Output 24 V DC max. 25 A fl. (blade fuse type FK2 in accordance with DIN 72581 T3) monitored by CS 445
	F9	Output 24 V DC max. 5 A fl. (blade fuse type FK2 in accordance with DIN 72581 T3) (not monitored, for supply of the CS 445 and U-OUT-AUX)
B	CPO 01 output connections protected by F1 - F9	
	U-OUT-1 to U-OUT-8	24 V DC outlets to the rack units M4 screw connection for leads < 10 mm <sup>2</sup> or FAST ON connector / 2 pin / for leads < 4 mm <sup>2</sup>
	U-OUT-AUX	24 V DC outlet M4 screw connection for leads < 10 mm <sup>2</sup> or FAST ON connector / 2 pin / for leads < 4 mm <sup>2</sup>
C	GND rail 8 connections as outlets to the rack units (M4 screw connection for leads < 10 mm <sup>2</sup> ) 3 connections as inputs for the CS 410 (M6 screw connection for leads < 16 mm <sup>2</sup> )	
D	Connections for DC IN for each CS 410 power module (M6 screw connection for leads < 16 mm <sup>2</sup> ) 24 V DC preliminary fuse, 63 A anti-surge	

E	<p>Connections for AC IN for each CS 400 power module</p> <p>MATE-N-LOK 3 pin connector for leads &lt; 4 mm<sup>2</sup></p> <p>Plug connection:</p> <p>Pin 1: N (blue)</p> <p>Pin 2: L1 (brown)</p> <p>Pin 3: PE (Green/Yellow)</p> <p>Single phase 50...60 Hz / 115 V...230 V</p> <p>Preliminary fuse 16 A anti-surge / 10 A anti-surge</p>	
F	Connectors for signals 3 x PCB 8-pin terminal strips for leads < 1.5 mm <sup>2</sup>	
	ALARM-IN-1	Connector X8 / pin 1 + 2 Input free for allocation (contact closed=fault) H-signal=12...33 V / > 47 kOhm L-signal < 5 V (Can optionally be switched to L+ or L-)
	ALARM-IN-1-GND	

ALARM-IN-2 ALARM-IN-2-GND	Connector X8 / pin 3 + 4 Input free for allocation (contact closed=fault) H-signal=12...33 V / > 47 kOhm L-signal < 5 V (Can optionally be switched to L+ or L-)
ALARM-IN-3 ALARM-IN-3-GND	Connector X8 / pin 5 + 6 Input free for allocation (contact closed=fault) H-signal=12...33 V / > 47 kOhm L-signal < 5 V (Can optionally be switched to L+ or L-)
ALARM-IN-4 ALARM-IN-4-GND	Connector X8 / pin 7 + 8 Input free for allocation (contact closed=fault) H-signal=12...33 V / > 47 kOhm L-signal < 5 V (Can optionally be switched to L+ or L-)
ERROR-OUT-S ERROR-OUT-GND	<p>Connector X9 / pin 1 + 2 1 x collective alarm, includes:</p> <ul style="list-style-type: none"> <li>• F1 fuse triggered</li> <li>• F2 fuse triggered</li> <li>• F3 fuse triggered</li> <li>• F4 fuse triggered</li> <li>• F5 fuse triggered</li> <li>• F6 fuse triggered</li> <li>• F7 fuse triggered</li> <li>• F8 fuse triggered</li> <li>• Input ALARM-IN-1</li> <li>• Input ALARM-IN-2</li> <li>• Input ALARM-IN-3</li> <li>• Input ALARM-IN-4</li> <li>• Power unit inserted in position 1 faulty</li> <li>• Power unit inserted in position 2 faulty</li> <li>• Power unit inserted in position 3 faulty</li> </ul> <p>Collective alarm (H-signal=fault) H-signal=12...33 V / &lt; 100 mA (to L-) L-signal &lt; 5 V / &lt; 100 µA (to L-) short-circuit protected, overload protected</p>
RESERVED-1 RESERVED-1-GND	<p>Connector X9 / pin 3 + 4</p> <p>Reserved for extensions</p>
RESERVED-2 RESERVED-2-GND	<p>Connector X9 / pin 5 + 6</p> <p>Reserved for extensions</p>
RESERVED-3 RESERVED-3-GND	<p>Connector X9 / pin 7 + 8</p> <p>Reserved for extensions</p>
CLK CLK-GND	<p>Connector X10 / pin 1 + 2</p> <p>I<sup>2</sup>C-Bus (not currently used)</p>
DATA DATA-GND	<p>Connector X10 / pin 3 + 4</p> <p>I<sup>2</sup>C-Bus (not currently used)</p>
RCI-S RCI-GND	<p>Connector X10 / pin 5 + 6 RCI=Remote Control Input The secondary power circuits (F1 - F9) can be switched off:</p> <ul style="list-style-type: none"> <li>• by the switch on the CS 445 front panel (the switch contact is closed)</li> <li>• by the RCI input (switch closed).</li> </ul> <p>The two switches operate in parallel.</p> <p>Power unit ON &gt; 100 kOhm (or open-circuit) (to L-)</p> <p>Power unit OFF &lt; 10 Ohm (to L-)</p>

# 6 Equipping Levels

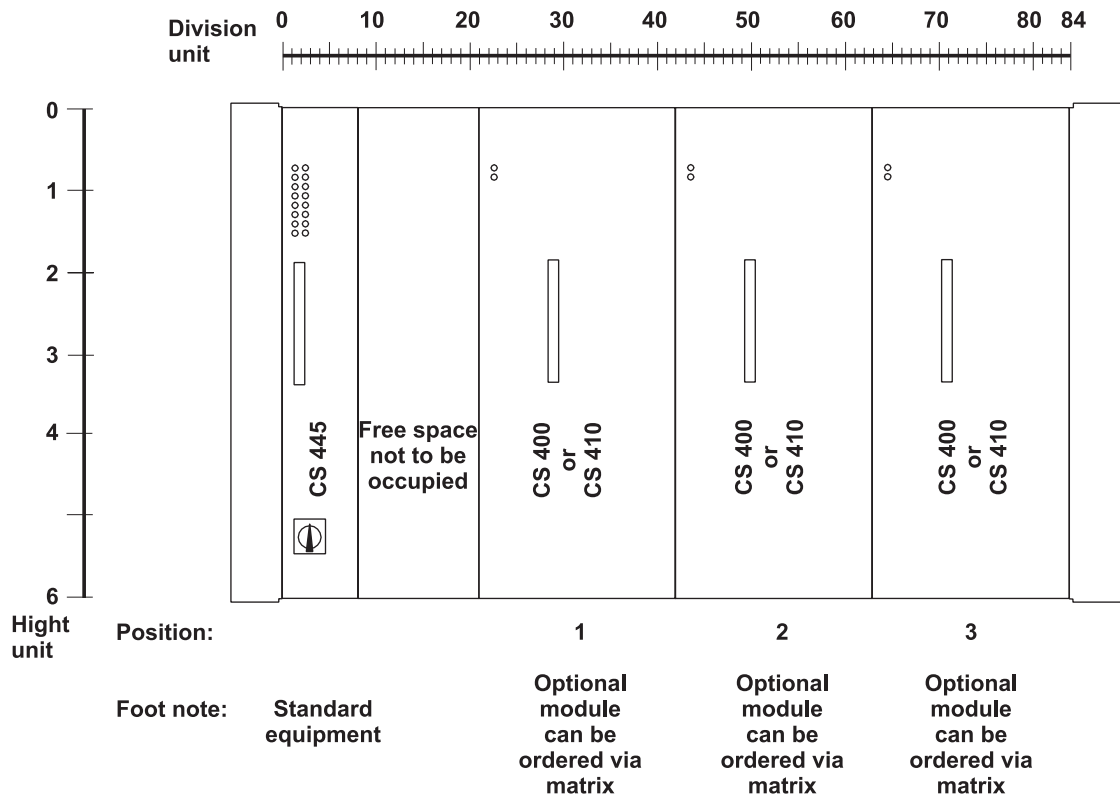

Order of the equipment of the power supply units acc. to order matrix.

Required space of the power supply units:

- CS 400 power supply unit AC / DC 21 TE
- CS 410 power supply unit DC / DC 21 TE
- CS 445 monitoring 8 TE

## 7 Technical Data

### 7.1 Technical Data for the CPO 01

Model	CPO 01 Cabinet Power Supply			
Dimensions		19" rack		
	Slots	Number of slots	1 x for CS 445 monitoring module ( 8 DU ) 3 x for power modules CS 4x0 ( 21 DU each ) 1 x empty slot, not usable ( 13 DU )	
	Width	483 mm		
Weight	Height			
		Net Weight	without plug-ins	5.5 kg fully occupied by 3 x CS 400 19.9 kg fully occupied by 3 x CS 410 12.7 kg
	Voltage supply		For the CS 400 power supply unit	<a href="#">See Section 5 [E]</a> For the CS 410 power supply unit <a href="#">See Section 5 [D]</a>
Outputs	Nominal voltage	24 V=		
		Rated current with 1 power unit	35 A	
Rated current with 2 power units Redundant operation:	35 A			
Rated current with 3 power units Parallel operation:	105 A			
Rated current with 3 power units Redundant operation (2 out of 3):	70 A			

For permissible environmental conditions and physical data see the "Standard Data" data sheet 72-0.11 for application class(es) A + B.

## 7.2 Technical Data CS 400 / CS 410

The CS 4x0 power supply modules convert a variable input voltage into a fixed output voltage with a nominal value of 24 V DC. They are capable of maintaining output through brief ( $\leq 20$  ms) interruptions in the input supply.

Model	Type	CS 400	CS 410	
	Dimensions	Height	Structural form F, 6 HU (266 mm)	
Net weight			4.7 kg	2.3 kg
Front panel	Color	RAL 7043		
Input	Voltage	Single phase 50-60 Hz / 115...230 V	21...33 V=	
	Output	General	Short-circuit protected, safe against overload, can be connected in parallel with automatic load distribution	
Protection circuits		Current limit	45...55 A at $U_{Out} > 5$ V 50...60 A at $U_{Out} \leq 5$ V Overload time $\geq 5$ s (to cut-out activation) Over-voltage $U_{out} \geq 33$ V (forced switch-off) Over temperature $T_{over} > 60$ °C (forced switch-off)	
	Output	UV/F monitoring (via backplane to CS 445)	H-signal ( $> 12V/R_i=4.7$ kOhm)=OK signal L-signal ( $< 5V/R_i=5.2$ kOhm)=Fault signal	
	Input	REMOTE ON/OFF (via backplane from CS 445)	ON=not connected OFF= $R_a < 10$ Ohm	
Idle voltage		25.5 V $\pm$ 0.5 %		
Internal resistance		33 mOhm $\pm$ 10 %		
		40 A at 35 °C ambient temperature 21 DU (105.84 mm)		
Minimum current		0 A (open circuit safe)		
Depth		Structural form F long (220 mm)		
Residual ripple		$< 250$ mV <sub>pp</sub> at $I_{nom} 10$ A / 5 A		
Max. current consumption		$< 65$ A		
Dynamic behavior		$U_{out} \pm 10$ % for $< 1$ ms $< 2 : 1$		
Crest factor		-		
Efficiency		$< 85$ % at maximum current		
Mains failure bridging		$\leq 20$ ms		

### 7.3 Technical Data for the CS 445

The CS 445 monitoring and signalling module evaluates the signals presented to its inputs. When it recognizes a fault it sets the "collective alarm" output. The Remote ON-OFF switch is used to switch the whole of the secondary side of the cabinet power supply on or off.

Model	Type	CS 445	
Dimensions	Height	Structural form F, 6 HU (266 mm)	
	Net weight		0.3 kg
Front panel	Color	RAL 7043 Instruments 16 light emitting diodes (green / red) 1 rotary switch: remote ON-OFF	
Voltage supply	Voltage	24 V= max. current consumption 120 mA at U nom	
Inputs	4 x freely assignable inputs External: ALARM-IN-1 to ALARM-IN-4	<a href="#">See Section 5 [F]</a>	
	Outputs	1 x collective alarm	<a href="#">See Section 5 [F]</a> 2-wire interface External: CLK / DATA <a href="#">See Section 5 [F]</a>
	8 x fuse cut-out (F1 to F8) (Internal from the CPO 01 backplane)	H-signal=12...33 V / > 20 kOhm (to L-) L-signal ≤ 5 V (to L-)	
	3 x power supply unit monitoring (Internal via backplane from the inserted C 4x0 power supply units)	H-signal=12...33 V / (or not connected)	
1 x lamp / function test External: FCT-Depth	<a href="#">See Section 5 [F]</a> Structural form F long (220 mm)		
1 x remote ON-OFF External: RCI-S	<a href="#">See Section 5 [F]</a>		

## 8 Ordering information

Order - number								Description	Delivery time
Delivery of individual parts									
72365-4-	0	3	3	8	8	3	0	Signalling / monitoring module CS 445	
73559-4-	0	7	4	6	5	7	8	CS 400 power supply module (input 115/230 V AC); Output 24 V DC, 30 A	
72386-4-	0	3	3	6	1	3	7	CS 410 power supply module (input 24 V DC); Output 24 V DC, 30 A	

Item no.							Description	Delivery time
0	3	3	6	7	6	7	5m cable with Mate-N-Lok plug and safety plug	
0	4	5	7	6	0	9	Housing, 3 pin	
0	5	4	6	7	6	6	Mate-N-Lok connector socket contacts 3 off per connector / special tool (crimp) required	
0	7	4	5	3	2	8	Contact strip with threaded terminal end for 8-pin PCB terminal strip	
0	7	4	5	3	3	6	Cable housing for 8-pin PCB terminal strip	
0	7	4	6	5	1	4	Fuse insert, type FK2 / 5.0 A	
0	7	4	5	8	9	0	Fuse insert, type FK2 / 7.5 A	
0	7	4	5	8	9	1	Fuse insert, type FK2 / 25 A	

For connecting cable, see Data Sheet 72-6.70 "Cables and Adapters"

Order - number								Description	Delivery time
								Cabinet Power Supply CPO 01	
72373-0-	x	x	x	0	0	0	0	19" rack, 6 HU, with: <ul style="list-style-type: none"> <li>• 1 off signalling / monitoring module CS 445</li> <li>• 3 off Mate-N-Lok housings (corresponding connector for AC supply input AC-IN-1 to 3)</li> <li>• 9 off Mate-N-Lok socket contacts (for the Mate-N-Lok housings, special tool needed for assembly)</li> <li>• 3 off 8 pin contact strip (corresponding connector for the signal input / output)</li> <li>• 3 off cable housing for contact strip cable routing</li> <li>• 8 off M6 x 16 bolts for fastening the rack in the cabinet</li> </ul>	
								In position 1	
	1							CS 400 power supply module (input 115/230 V AC); Output 24 V DC, 30 A inc. 5m cable with Mate-N-Lok plug and safety plug	
	2							CS 410 power supply module (input 24 V DC); Output 24 V DC, 30 A	
								In position 3	
		0						none	
		1						CS 400 power supply module (input 115/230 V AC); Output 24 V DC, 30 A inc. 5m cable with Mate-N-Lok plug and safety plug	
		2						CS 410 power supply module (input 24 V DC); Output 24 V DC, 30 A	
								In position 2	
			0					none	
			1					CS 400 power supply module (input 115/230 V AC); Output 24 V DC, 30 A inc. 5m cable with Mate-N-Lok plug and safety plug	
			2					CS 410 power supply module (input 24 V DC); Output 24 V DC, 30 A	
72373-0-	x	x	x	0	0	0	0		
								Additional ordering information	
								Unpackaged for cabinet fitting in HGS (The Ba no. 601 does not replace the assembly identifier "H"!)	Ba no. 601
								Packaging for the supply of individual parts inc. 9 off flat plugs 6.3 x 0.8	Ba no. 602







Industriestraße 28  
65729 Eschborn  
Tel. (06196) 800-0  
Fax (06196) 800-11 19

Höseler Platz 2  
42567 Heiligenhaus  
Tel. (0 20 56) 12- 0  
Fax (0 20 56) 12- 56 79

Kohlstraße 4  
32425 Minden  
Tel. (05 71) 830- 0  
Fax (05 71) 830- 11 05

## **ABB Automation Products**