



Substation Automation Products

Line differential protection RED670 Relion[®] 670 series

For maximum reliability of your power system

The RED670 IED (Intelligent Electronic Device) is designed for protection, monitoring and control of overhead lines and cables with up to five line terminals. The phase segregated line differential protection of RED670 enables reliable single/two/three pole tripping and auto-reclosing with synchronizing and synchro-check. In addition, this IED is capable of handling transformer feeders, and generator and transformer blocks. It provides an extensive functionality with application opportunities and expandable hardware to meet your specific requirements.

RED670 provides absolutely selective protection without time grading. All line short circuits and earth faults can be cleared instantaneously. Additionally, the high sensitivity of RED670 allows for detection of small fault currents, which in turn allows high resistive phase to earth faults to be detected.

Ready to use IEDs

The RED670 IEDs are delivered pre-configured, type tested and with default parameters for easy handling of products – from ordering, engineering and commissioning to reliable operation. These IEDs are equipped with complete functionality adapted for four different configuration alternatives: single pole breaker or multi-breaker arrangements with single or three phase tripping. If needed, they can also be easily adapted for your power system's specific requirements.



Increase grid reliability – Invest in an intelligent solution

- RED670 provides phase segregated line differential protection for up to five line terminals including power transformers in the protected zone
- RED670 provides redundancy based on integrated distance protection
- RED670 provides improved availability through outstanding performance and efficient information management for any high voltage application
- Ready-to-use RED670 IEDs enable significant savings and reliable operation
- RED670 provides you with an integrated solution for protection, control and monitoring

Protection for up to five line terminals

RED670 provides phase segregated line differential protection for two to five line terminal applications in impedance or solidly earthed networks, including [series compensated systems](#).

All individual phase currents in 11/2 and multi-breaker configurations can be connected to RED670 without external summation. Therefore, each current will always be correctly measured. This [improves the stability of the line differential protection function](#) and [enables integration of a number of breaker related protection and control functions](#).

Power transformer in the protected zone

RED670 is able to handle [two or three-winding power transformer\(s\) in the protected zone](#). The line differential protection function handles all transformer winding vector groups and matches all transformer configurations with a simple parameter setting. This simplifies engineering since no auxiliary CTs or other protection equipment is needed.

[Advanced stabilization methods](#) are used for detection of transformer inrush current during energization to ensure sensitive differential protection when a power transformer is included in the protected zone.

When a small transformer is connected as a tap on the line, the line differential protection can be used without having an additional RED670 installed at the transformer tap. For low fault currents behind the tap transformer the line differential protection of RED670 includes a useful definite time or inverse time delayed characteristic. This enables selective operation of other protection functions located at the tapped transformer's high or low voltage side.

Extensive built-in protection for lines and cables

The RED670 features integrated distance protection to ensure fault clearance in case of communication failure. The [full scheme](#) distance protection provides independent phase selection, power swing detection and a wide range of scheme communication logics. The four-zone distance protection is further enhanced with [load encroachment](#), which increases the ability to detect high resistive faults on heavily loaded lines.

You can increase the functionality of your RED670 IEDs with [optional back-up and multipurpose protection functions](#). Versatile overcurrent and thermal overload functions provide additional back-up protection. Breaker failure protection allows high speed back-up tripping of surrounding breakers and re-tripping of the own breaker, for instance, to avoid

Integrated protection and control

operational mistakes during testing. The distance directional earth fault overcurrent and directional negative sequence overcurrent functions can communicate with the remote end in any communication scheme.

In addition to the wide range of overcurrent protection functions, RED670 provides a [negative sequence overcurrent protection](#). This function detects all unsymmetrical faults with or without earth connection. It features high sensitivity, which [enables detection of faults with low fault current](#). The negative sequence overcurrent protection can also be used as directional. This facilitates the coordination with protection for other objects.

The four-step negative sequence overcurrent protection can serve as back-up protection for most faults. It can also serve as the main protection for earth faults and other unsymmetrical faults.

Integrated protection and control

RED670 is designed for IEC 61850, implementing all the aspects of this standard and thus ensuring open, future-proof and flexible system architectures, with state-of-the-art performance. It features extensive functionality and expandable I/O. As a result, [you can benefit from applications with multiple algorithms and comprehensive bay control functionality](#), such as synchronizing, synchro-check, dead-line detection and auto-reclosing in integrated and distributed architectures.

The advanced interlocking functionality of RED670 allows you to avoid dangerous or damaging switchgear operations, and thus ensure personnel safety. The control is based on the select before operate principle to assure secure operation and to avoid human mistakes.



Application examples

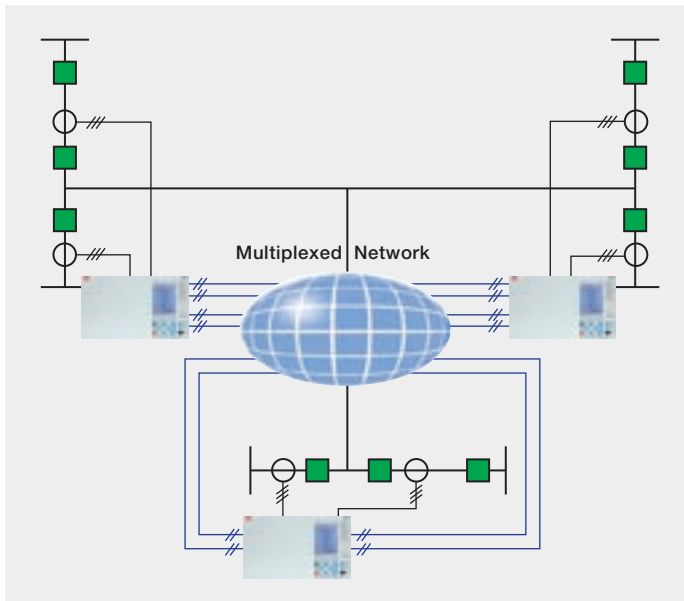

RED670 in three-terminal line application with individual phase current exchange.

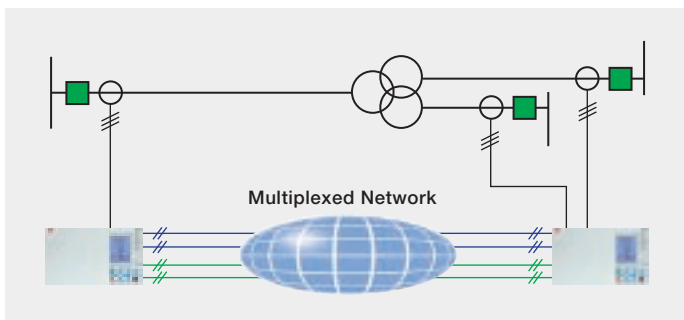

RED670 for line and three-winding transformer application with individual phase current exchange and redundant communication.

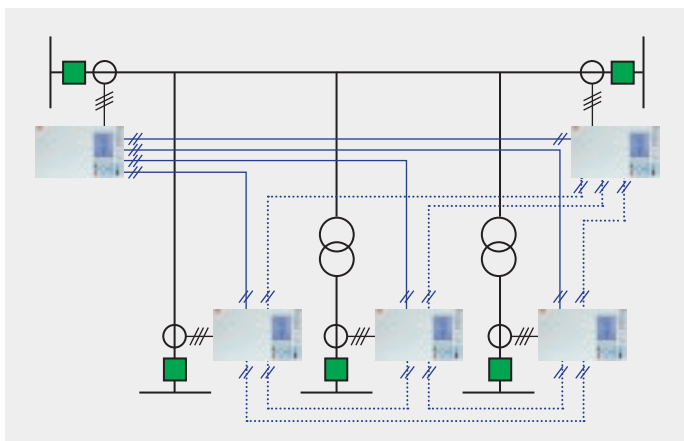

RED670 for five-terminal line application in master-master or master-slave operating mode.

The integrated HMI of RED670 allows secure and quick local control for stand-alone applications and provides back-up control for substation automation systems. It also enables instant access to important data, such as settings, events and disturbance information.

The two-position versatile switch and the 32-position selector switch functions enable you to easily manage switching operations via an icon on the IED HMI. The versatile switch function allows you to directly change, for instance, the autorecloser function from On to Off or vice versa without changing the configuration. The function also presents an indication of the selected position.

The selector switch can replace an external mechanical selector switch and allows you to directly select the position you desire, for instance, to change the auto-recloser mode between 1-pole, 3-pole or 1- & 3-pole modes. In addition to the IED HMI, these switch functions can be operated from a remote system.

The RED670 IEDs provide you with a future-proof concept based on wide application flexibility, which makes these IEDs an excellent choice for both new and retrofit installations.

Protection communication according to the standards

Due to development in communication technologies and synchronization of measurements, line differential protection can be used in a wide range of applications. Consequently, you can also protect long lines using line differential protection and still maintain high security. RED670 can exchange phase current and binary signal information between up to five line terminals.

The RED670 IEDs are designed to communicate. They feature extensive supervision of communication channels and provide detailed information for fast restoration of the communication system. The built-in C37.94 interface of the RED670 enables easy and safe standardized optical connection to "off-the-shelf" communication equipment.

You can:

- Choose either master-master or master-slave operating mode depending on your system's functionality or your economic requirements.
- Connect RED670 to redundant channels to increase the dependability of the protection scheme.
- Use GPS or IRIG-B module for time tagging of samples, which allows RED670 to be used in switched networks with unequal channel delays.
- Use the echo-synchronization method for channels with stable and equal delays in both directions without time tagging of samples via GPS.

RED670 IEDs can also provide [additional logic in the direct transfer trip schemes](#) to minimize the risk of unwanted operation caused by a false signal in protection communication. Several different protection functions can be used as local criteria when configuring the logic for a specific application. Furthermore, the line differential protection function offers additional local criteria, such as phase-to-phase current variation. This ensures correct operation of the IED in case data is lost due to frequent failures in protection communication. Consequently, the protection system security is maintained, and the risk of interruption in electricity supply to customers is reduced.

Fast and efficient system integration

RED670 IEDs are [more than just devices](#). They utilize ABB's unique connectivity package concept, which simplifies the system engineering and reduces the risks of errors in system integration. This package contains a complete description of the specific IED, consisting of data signals, parameters, addresses and IED documentation.

The signal data is configured automatically based on the information provided by the connectivity package to efficiently integrate the IEDs in ABB's MicroSCADA Pro automation system.

Relion® 670 series IEDs support [IEC 62439 standard redundant communications on the station bus](#). The solution from ABB utilizes the IEC 62439-3 [standardized Parallel Redundancy Protocol \(PRP\)](#). PRP improves the communication system reliability and features a unique capability of zero seconds' recovery time in case of communication failures. This means that there will be [no interruption in communication](#) if one link fails as the other link instantaneously takes over the communication. As a result, there is no data lost when communication failures have occurred.

The [supervision of communication links](#) provides real-time status information about both communication links individually. If a failure occurs, an alarm is sent to the IED HMI and the substation automation system. This also allows for maintenance of the station bus while it is in operation. Thus, redundant communication further [improves personnel safety](#) and ensures that the [necessary information](#) about the system is available [for operators in all situations](#).

Relion 670 series IEDs can also [support synchronized sampled measured value communication over the process bus using IEC 61850-9-2 LE](#) which replaces conventional wiring between the process and the secondary system. This enables new design of substations. For example, utilization of sensor technology eliminates problems caused by, for instance, CT saturation and EMC influence. Furthermore, extensions and maintenance of substations can be completed more efficiently as fiber-optic cables are used instead of copper wires.

670 series IEDs allow you to mix conventional wiring and fiber-optic communication with IEC 61850-9-2 LE in a single IED. This way you can shift from conventional wiring for analog data to fiber-optic-based communication for synchronized sampled measured values step by step.

Relion® – Complete confidence

Line differential protection RED670 is a member of the Relion® protection and control product family. The Relion product family offers the widest range of products for the protection, control, measurement and supervision of power systems. To ensure interoperable and future-proof solutions, Relion products have been designed to implement the core values of the IEC 61850 standard. With ABB's leading-edge technology, global application knowledge and experienced support network, you can be completely confident that your system performs reliably – in any situation.



Features

- Fully IEC 61850 compliant
- Control, monitoring and protection integrated in one IED
- Extensive self-supervision including analog channels
- Six independent parameter setting groups
- Large HMI for visualization of single line diagrams
- Ethernet interface for fast and easy communication with PC
- Signal matrix for easy configuration of binary and analog signals
- Advanced multi-terminal line differential protection
- Extensive supervision of communication channels
- User management and authority handling

Pre-configured solutions

- Pre-configured and tested solutions including default settings for:
 - Single breaker with selective single or three phase tripping
 - Double breaker with selective single or three phase tripping
 - 11/2 circuit breaker arrangements with selective single or three phase tripping
 - Sub-transmission high impedance earthed systems (single breaker)

Most important protection functions

- Line differential protection
 - Phase segregated line differential protection with charging current compensation for up to five line terminals
 - Power transformers can be included in the protected zone
 - Suitable for multiplexed, route switched, as well as dedicated fibre, communication networks using C37.94 protocol
 - Time synchronization with the echo-method or built-in GPS
 - Master-master or master-slave line differential communication arrangement
- High impedance differential protection for tee-feeders
- Additional security logic
- Distance protection
 - Full-scheme distance protection with quadrilateral, Mho- or series compensation characteristics for up to four zones, and with load encroachment
 - Power swing detection
 - Phase preference logic
 - Pole slip protection
- Current
 - Instantaneous phase- and residual overcurrent protection
 - Four-step phase- and residual directional overcurrent protection with definite and inverse time characteristics
 - Four-step negative sequence directional overcurrent protection
 - Directional residual overcurrent protection with scheme communication logic
 - Current reversal and weak end infeed logic
 - Sensitive directional earth-fault protection
 - Broken conductor
 - Thermal overload protection
 - Breaker failure protection
 - Stub protection
 - Pole discordance protection
- Power functions
 - Directional under- and over power protection
- Voltage
 - Two step phase- and residual overvoltage protection with definite and inverse time characteristics
 - Two step undervoltage protection with definite and inverse time characteristics
 - Voltage three-phase differential for capacitor banks
 - Overexcitation protection
 - Loss of voltage
- Power system supervision
 - Loss of voltage check configured based on undervoltage protection
 - Dead line detection included in fuse failure supervision and switch on to fault logic
- Secondary system supervision
 - Fuse failure supervision
 - Current circuit supervision
- Frequency functions
 - Over- and under-frequency protection

- Rate-of-change frequency protection
- Multipurpose function
 - General current and voltage protection

Logic

- Tripping logic
- Trip matrix logic
- Configurable logic blocks

Monitoring

- Disturbance recorder
 - 100 disturbances
 - 40 Analog channels 30 physical and 10 derived
 - 96 Binary channels
- Event list for 1000 events
- Disturbance report
- Event and trip value recorders
- Fault locator
- Event counters
- Supervision of AC and mA input quantities
- Small and large HMI in local language
- LED indications with 6 red and 9 yellow LEDs

Metering

- U, I, P, Q, S, f, and cosφ
- Differential voltage per zone
- AC input quantities with accuracy better than 0,5%
- Inputs for mA measuring
- Energy metering function for energy statistic
- Pulse counting support for energy metering

Control functions

- Apparatus control for 8 or 15 apparatus
- Ready to use interlocking modules for different switchgear arrangements
- Several alternatives for reservation functionality
- Synchronizing, synchro-check and energizing check
- Auto-recloser
- Versatile switch with two positions
- Selector switch with up to 32 positions

Communication

- IEC 61850-8-1 including GOOSE messaging
- IEC 61850-9-2 LE Process bus
- Individually supervised redundant station bus with zero seconds recovery time
- IEC 60870-5-103
- DNP 3.0 slave protocol
- LON
- SPA
- Remote end communication for transfer of eight binary signals

Setting, configuration and disturbance handling

- Protection and Control IED Manager PCM600

Hardware

- 1/1 x 19", 3/4 x 19" or 1/2 x 19", 6U height case selected according to the number of required I/O modules
- TRM module with measurement transformers
- ADM module
- Power supply modules from 24 to 250 V DC ± 20%
- Up to 14 I/O modules in 1/1 x 19" case
- Binary input module, 30 mA and 50 mA, with 16 inputs
- Binary output module with 24 outputs
- Static binary output module with 12 outputs (6 static)
- Binary input/output module, 30 mA and 50 mA, with 8 inputs and 12 outputs
- mA input module with 6 transducer channels
- Accurate time-synchronization through GTM, GPS time module, IRIG-B-module, SNTP and DNP 3.0
- Remote end data communication modules for C37.94, X21 and G.703/G.703E1
- COMBITEST test switch module

Technical details are available in the RED670 Product Guide.

Contact us

ABB AB

Substation Automation Products

SE-721 59 Västerås, Sweden

Tel. +46 21 32 50 00

Fax +46 21 14 69 18

www.abb.com/substationautomation