



Substation Automation Products

Transformer protection RET670/650 Relion[®] 670 and 650 series

For reliable protection and control of all types of power transformers and reactors

RET670/650 IEDs (Intelligent Electronic Device) provide fast and selective protection, monitoring and control for all types of transformers, such as two and three-winding transformers, step-up transformers in power stations and special railway transformers. In addition, RET670 offers state-of-the-art protection for autotransformers, phase shifting transformers and shunt reactors including switching control. With up to six three phase restraint current inputs into differential protection, it allows for multi-breaker substation arrangements on any winding. The advanced RET670 and RET650 communication capabilities allow you to integrate these IEDs into your substation automation system or use them as stand-alone multifunctional units.

The transformer protection IEDs offer several solutions for voltage control. Voltage control can be integrated in the same IED together with differential protection function and back-up protection functions, or as a separate stand-alone voltage control unit. The advanced voltage control functionality of RET670 is capable of handling single and up to eight parallel transformers in any combination of parallel groups. RET650 provides a solution for single transformer voltage control and for two parallel operating transformers.

These IEDs provide you with a [future-proof concept](#) based on application flexibility, which makes them an excellent choice for both new and retrofit installations. The integration of the main protection and a wide range of back-up protection functions within these IEDs improve your power system performance. It also reduces engineering and installation time as well as space and spare parts requirements.

RET670 – optimized for transmission applications

RET670 IEDs provide [customized or pre-configured protection solutions for any type of transformer and shunt reactor application](#). The customized RET670 gives you the freedom to select functionality entirely according to your needs. The pre-configured RET670 variants simplify handling since the basic functionality is included and pre-configured. If needed, you can add optional functions to increase the functionality of the pre-configured RET670 IEDs to meet the specific requirements of your transformer or shunt reactor.

You can also [protect and control several objects with a single RET670 IED](#). For instance, a single RET670 IED can integrate complete protection and control functionality for a transformer and a connected transmission line. The distance protection function can also be used as back-up protection for faults within the



transformer. This solution provides efficient protection and control in FACTS installations. The distance protection function can also be used as back-up protection for faults in the connected lines. The parameters related to line distance protection are mostly set as primary ohms, which significantly reduce the need to re-calculate the current and voltage values. This [allows the IEDs to be quickly taken into operation](#). The application manual includes setting examples to support the protection engineer. In all, RET 670 [increases both the reliability and profitability of your entire power system](#).

RET650 – your best choice for sub-transmission applications

RET650 offers [optimum 'off-the-shelf', ready-made solutions](#) for protection of two- and three winding transformers, including voltage control for a single transformer. Additionally, a separate voltage control unit can handle two parallel operating transformers and integrate back-up protection functionality.

The type tested variants of RET650 IEDs are delivered equipped and configured with complete functionality and with default parameters for easy handling of products – from ordering, engineering and commissioning to reliable operation.

The 650 series IEDs introduce a number of innovations, such as a [significantly reduced number of parameter settings](#) and [extended IED HMI functionality](#) including 15 dynamic three- color-indication LEDs per page, on up to three pages, and configurable push-button shortcuts for different actions. In the 650 series IEDs, most basic parameters are set before delivery from the factory. You only need to set the parameters specific to your application.

Unrivalled sensitivity and speed

The extremely fast differential protection of RET670 makes it the ideal solution in the most demanding applications. The differential protection function in RET670 features tap-changer position adaptation, which significantly increases the sensitivity of the IEDs. This offers [the best possible coverage for power transformer winding turn-to-turn faults, including low-level internal faults](#). The [unique negative sequence internal/external fault discriminator](#) is faster than a conventional stabilized transformer differential protection function. It also enables extremely sensitive protection to detect evolving internal faults so that the system can be tripped before a more severe fault with serious damages occurs. RET670 and RET650 place low requirements on the main CTs and no interposing CTs are needed.

The low impedance restricted ground fault function for all directly or low impedance grounded windings ensures high sensitivity and fast tripping. The additional directional zero sequence current criterion of this function increases security.

Non-directional and/or directional overcurrent functions provide the necessary back-up protection. This, together with fast and sensitive

restricted ground fault protection of stabilized low impedance types, with sensitivity down to 1% of the total number of turns, ensures [comprehensive protection for your power transformers](#). The thermal overload function prevents transformer damage caused by overload. Breaker failure protection allows high speed back-up tripping of surrounding breakers and re-tripping of the own breaker, for instance, to avoid operational mistakes during testing.

Intelligent protection investment

Integrated under-/over voltage and frequency protection functions make these IEDs [ideal for use in power plant applications](#), where they handle part of the tasks of generator protection, or provide back-up for the generator protection. The IEDs are designed to operate correctly over a wide frequency range in order to accommodate power system frequency variations during disturbances and generator start-up and shut-down.

The [capacitor bank protection](#) in RET670 [detects dangerous operation situations and trips before any damage occurs](#) in capacitor units that are vulnerable to different phenomena in power systems.

The capacitor bank protection in RET670 IEDs consists of overcurrent protection, undercurrent protection, harmonic overload protection, reactive power overload protection and a reconnection inhibit function. These, together with other protection functions that can be included in RET670 IEDs, such as unbalance protection based on overcurrent protection, provide complete protection for capacitor banks.

In addition to the wide range of overcurrent protection functions, RET670 provides a [negative sequence overcurrent protection](#). This function detects all unsymmetrical faults with or without ground connection. It features high sensitivity, [which enables detection of faults with low fault current](#). The negative sequence overcurrent protection can also be used as directional. This facilitates the coordination with protection for other objects.



Intelligent protection investment

The four-step negative sequence overcurrent protection can serve as back-up protection for most faults. It can also serve as the main protection for ground faults and other unsymmetrical faults.

Additionally, the advanced logic capabilities and multipurpose protection function of the RET670 allow you to [design special applications](#). These include automatic operation of disconnectors and load transfer logics for a double busbar, and special protection applications. The logic can be easily generated, tested and commissioned with the help of the graphical engineering tool.

Advanced voltage control

Tap changer control functions include line drop compensation and a load shedding function based on voltage reduction. RET670 IED's tap changer position monitoring with mA- or BCD-signals enables [supervision of the correct tap changer operation](#).

For parallel operating transformers, the RET670 and RET650 IEDs can utilize the minimum circulating current principle, which ensures the correct split of reactive power flow between each transformer in accordance with its rating. Using the average measured voltage between the IEDs within each group of transformers ensures the correct tap changer control. This also allows [easy and efficient supervision of VTs](#). Alternatively the master-follower principle can be used for transformers with similar characteristics. Automatic control for a hot-stand-by transformer can also be included.

The RET670 IED can be equipped with integrated advanced voltage control functionality for single and up to eight parallel transformers in any combination of parallel groups.

RET650 provides integrated voltage control for single transformers. The dedicated voltage control variant of RET650 is capable of handling two parallel operating transformers including back-up protection.

The right information for the right action

The integrated HMI of RET670 and RET650 provide you with [a quick overview of the status of the substation with position indications and service values](#). Using a library of symbols, you can easily configure the graphical display to correspond to your needs and to your substation. The built-in disturbance and event recorders provide you with [valuable data for postfault analysis and corrective actions to increase the security](#) of your power system.

RET670 also features also functions for [local and remote apparatus control on all sides of the transformer](#). Secure bay- and station-wide interlocking allows you to avoid dangerous or damaging switchgear operations and to ensure personnel safety. The large HMI allows for local control and instant access of important data, such as settings,



events and disturbance information. You can locally control and visualize up to 30 primary apparatus with one RET670 IED.

The two-position versatile switch and 32-position selector switch functions of RET670/650 enable you to [easily manage switching operations via an icon on the IED HMI](#). The versatile switch function allows you to directly change, for instance, a voltage control function from manual to automatic mode. The function also presents an indication of the selected position. The selector switch can replace an external mechanical selector switch and allows you to [directly select the position you desire](#). In addition these switch functions can be also operated from a remote control system.

The HMI of RET650 features [15 dynamic three-color status indication LEDs on up to three pages](#), which is useful in maintenance and operation routines. It also has [five configurable push-button shortcuts](#) that can be used for different actions.

Optimized utilization of transformers

The monitoring functionality of the RET670 and RET650 IEDs provides [important information about the state of the transformers](#) to an operator. The RET670 IEDs receive information about the transformer temperature and issue an alarm, log the event and trip if needed. This gives the operator time to disconnect the transformer in case of an overload during network emergency conditions. Early actions [prevent forced ageing and prolong the transformer lifetime](#). The information about temperature can also be used to control the cooling system of the transformer.

Fast and efficient system integration

The RET670 and RET650 IEDs are [designed for IEC 61850](#), implementing all aspects of this standard, thus ensuring open, future-proof and flexible system architectures, with state-of-the-art performance. They utilize ABB's unique connectivity package concept, which simplifies the system engineering and reduces the risks of errors in system integration. A connectivity package contains a complete description of the specific IED, consisting of data signals,

parameters, addresses and IED documentation. The signal data is configured automatically based on the information provided by the connectivity package to efficiently integrate the IEDs into ABB's MicroSCADA Pro automation system.

Relion® 670 series IEDs support [IEC 62439 standard redundant communications on the station bus](#). The solution from ABB utilizes the IEC 62439-3 [standardized Parallel Redundancy Protocol \(PRP\)](#). PRP improves the communication system reliability and features a unique capability of zero seconds' recovery time in case of communication failures. This means that there will be [no interruption in communication](#) if one link fails as the other link instantaneously takes over the communication. As a result, there is no data lost when communication failures have occurred.

The [supervision of communication links](#) provides real-time status information about both communication links individually. If a failure occurs, an alarm is sent to the IED HMI and the substation automation system. This also allows for maintenance of the station bus while it is in operation. Thus, redundant communication further [improves personnel safety](#) and ensures that the [necessary information](#) about the system is available [for operators in all situations](#).

Relion 670 series IEDs can also [support synchronized sampled measured value communication over the process bus using IEC 61850-9-2 LE](#) which replaces conventional wiring between the process and the secondary system. This enables new design of substations. For example, utilization of sensor technology eliminates problems caused by, for instance, CT saturation and EMC influence. Furthermore, extensions and maintenance of substations can be completed more efficiently as fiber-optic cables are used instead of copper wires.

670 series IEDs allow you to mix conventional wiring and fiber-optic communication with IEC 61850-9-2 LE in a single IED. This way you can shift from conventional wiring for analog data to fiber-optic-based communication for synchronized sampled measured values step by step.

Relion® – Complete confidence

Transformer protection RET670/650 IEDs belong to the Relion® protection and control product family. The Relion product family offers the widest range of products for the protection, control, measurement and supervision of power systems. To ensure interoperable and future-proof solutions, Relion products have been designed to implement the core values of the IEC 61850 standard. With ABB's leading-edge technology, global application knowledge and experienced support network, you can be completely confident that your system performs reliably – in any situation.

Application examples

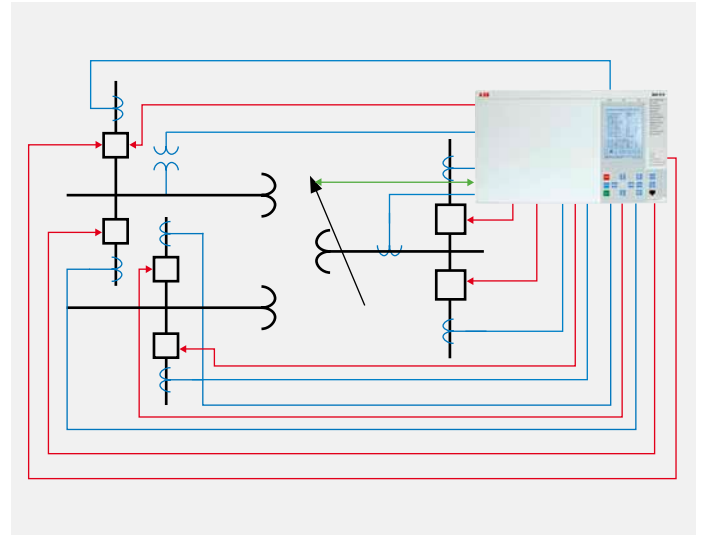

RET670 ensures enhanced through-fault stability for multi-breaker arrangements

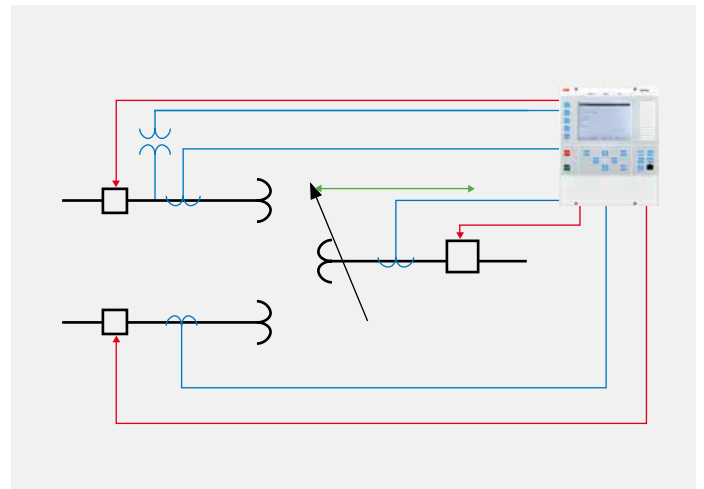

RET650 provides complete protection and control for two- and three- winding power transformers.

Features

- Fully IEC 61850 compliant
- Control, monitoring and protection integrated in one IED
- Extensive self-supervision including analog channels
- Six independent parameter setting groups
- Signal matrix for easy configuration of binary and analog signals
- Ethernet interface for fast and easy communication with PC
- Large HMI for visualization of single line diagrams
- User management and authority handling

Pre-configured solutions

- Pre-configured and type tested solutions including default settings for:
 - Two winding transformer in multi breaker arrangements
 - Two winding transformer in single breaker arrangements
 - Three winding transformer in multi breaker arrangements

Most important protection functions

- Transformer differential protection
 - Percentage bias restraint
 - Waveform and second harmonic restraint for transformer inrush
 - Fifth harmonic restraint for overexcitation
 - Automatic CT ratio matching and vector group compensation
 - High sensitivity for interturn faults
- High impedance differential protection
- Restricted ground fault protection
 - Extremely fast operation
 - High and low impedance based
- Distance protection
 - Full-scheme distance protection with quadrilateral, Mho- or series compensation characteristics for up to four zones, and with load encroachment
- Current
 - Instantaneous phase- and residual overcurrent protection
 - Four-step phase- and residual directional/non-directional overcurrent protection with definite and inverse time characteristics
 - Four-step directional negative sequence overcurrent protection
 - Two-step negative sequence non-directional overcurrent protection
 - Sensitive directional ground fault protection
 - Broken conductor
 - Thermal overload protection
 - Breaker failure protection
 - Pole discordance protection
 - Capacitor bank protection
- Power functions
 - Directional under- and over power protection
- Voltage
 - Two step phase- and residual overvoltage protection with definite and inverse time characteristics
 - Two step undervoltage protection with definite and inverse time characteristics
 - Overexcitation protection
 - Loss of voltage
- Secondary system supervision
 - Fuse failure supervision
 - Current circuit supervision
- Frequency functions
 - Over- and under-frequency protection
 - Rate-of-change frequency protection
- Multipurpose function
 - General current and voltage protection

Control functions

- Automatic voltage control for a single transformer
- Automatic voltage control for up to four/eight parallel transformers based on the minimum circulating current principle or master-follower principle
- Apparatus control for up to 30 apparatus

- Ready to use interlocking modules for different switchgear arrangements
- Several alternatives for reservation functionality
- Synchronizing, synchro-check and energizing check
- Versatile switch with two positions
- Selector switch with up to 32 positions

Logic

- Tripping logic
- Trip matrix logic
- Configurable logic blocks

Monitoring

- Disturbance recorder
 - 100 disturbances
 - 40 analog channels 30 physical and 10 derived
 - 96 binary channels
- Event list for 1000 events
- Disturbance report
- Event and trip value recorders
- Fault locator
- Event counters
- Supervision of AC and mA input quantities
- Small and large HMI in local language
- LED indications with 6 red and 9 yellow LEDs

Measurements

- U, I, P, Q, S, f, and $\cos\phi$
- Differential voltage per zone
- AC input quantities with accuracy better than 0.5%
- Inputs for mA measuring

Metering

- Energy metering function for energy statistics
- Pulse counting support for energy metering

Communication

- IEC 61850-8-1 including GOOSE messaging
- IEC 61850-9-2 LE Process bus
- Individually supervised redundant station bus with zero seconds recovery time
- IEC 60870-5-103
- DNP 3.0 slave protocol
- LON
- SPA
- Remote end communication for transfer of 192 binary signals

Setting, configuration and disturbance handling

- Protection and Control IED Manager PCM 600

Hardware

- 1/1 x 19", 3/4 x 19" or 1/2 x 19", 6U height case selected according to the number of required I/O modules
- Power supply modules from 24 to 250 V DC \pm 20%
- TRM module with measurement transformers
- ADM module
- Up to 14 I/O modules in 1/1 x 19" case
- Binary input module, 30 mA and 50 mA, with 16 inputs
- Binary output module with 24 outputs
- Static binary output module with 12 outputs (6 static)
- Binary input/output module, 30 mA and 50 mA, with 8 inputs and 12 outputs
- mA input module with 6 transducer channels
- Accurate time-synchronization through GTM, GPS time module, SNTP, DNP 3.0 or IIRIG-B-module
- Remote end data communication modules for C37.94, X.21 and G.703/G.703E1
- COMBITEST test switch module

Technical details are available in the RET670 Product Guide.

Features

- Fully IEC 61850 compliant
- Control, monitoring and protection integrated in one IED
- Extensive self-supervision including analog channels
- Four independent parameter setting groups
- Signal matrix for easy configuration of binary and analog signals
- Ethernet interface for fast and easy communication with PC
- Large HMI for visualization of single line diagrams
- Integrated or detachable HMI with 1-5 m cable for easy installation wiring
- User management and authority handling

Configured solutions

- Pre-configured and type tested solutions including default settings for:
 - Two winding transformer in single breaker arrangements
 - Three winding transformer in single breaker arrangements
 - Voltage control for two parallel transformers

Most important protection functions

- Transformer differential protection
 - Percentage bias restraint
 - Waveform and second harmonic restraint for transformer inrush
 - Fifth harmonic restraint for overexcitation
 - Automatic CT ratio matching and vector group compensation
 - High sensitivity for interturn faults
- Low Impedance Restricted ground fault protection
 - Extremely fast operation
- Current
 - Instantaneous phase- and residual overcurrent protection
 - Four-step phase- and residual directional/non-directional overcurrent protection with definite and inverse time characteristics
 - Sensitive directional ground fault protection
 - Negative sequence directional overcurrent protection
 - Broken conductor
 - Thermal overload protection
 - Breaker failure protection
 - Pole discordance protection
- Power functions
 - Directional under- and over power protection
- Voltage
 - Two step phase- and residual-overvoltage protection with definite and inverse time characteristics
 - Two step undervoltage protection with definite and inverse time characteristics
 - Overexcitation protection
 - Loss of voltage
- Secondary system supervision
 - Fuse failure supervision
 - Current circuit supervision
- Frequency functions
 - Over- and under-frequency protection
 - Rate-of-change frequency protection

Control functions

- Automatic voltage control for a single transformer
- Automatic voltage control for two parallel transformers based on the minimum circulating current principle or master-follower principle
- Versatile switch with two positions
- Selector switch with up to 32 positions

Logic

- Tripping logic
- Trip matrix logic
- Configurable logic blocks

Monitoring

- Disturbance recorder
 - 100 disturbances
 - 40 analog channels 30 physical and 10 derived
 - 96 binary channels
- Event list for 1000 events
- Disturbance report
- Event and trip value recorders
- Fault locator
- Event counters
- Supervision of AC input quantities
- Indication of up to 135 binary signals via 15 three-color-state indication LEDs on up to three pages

Measurements

- U, I, P, Q, S, f, and $\cos\varphi$
- Differential voltage per zone
- AC input quantities with accuracy better than 0.5%

Metering

- Energy metering function for energy statistics
- Pulse counting support for energy metering

Communication

- IEC 61850-8-1 including GOOSE messaging
- DNP 3.0 slave protocol

Setting, configuration and disturbance handling

- Protection and Control IED Manager PCM 600

Hardware

- 1/2 x 19", 6U height case
- Power supply modules from 48 to 250 V DC or 100 to 240 V AC with 9 outputs, which of 3 with trip circuit supervision
- Communication and processor module with 14 inputs
- Binary input/output module with 9 inputs and 9 outputs
- Accurate time-synchronization through IRIG-B-module

Technical details are available in the RET650 Product Guide.

Contact us

ABB Inc.

Operations, Engineering and
Sales Support Center
940 Main Campus Drive
Raleigh, NC 27606, USA
Toll Free: 1-800-HELP-365

ABB Inc.

Sales Support Center
3450 Harvester Road
Burlington, ON L7N 3W5, Canada
Toll Free: 1-800-HELP-365

ABB México S.A de C.V.

Sales Support Center
Paseo de las Américas No. 31
53125, Naucalpan, Edo. De Mexico, Mexico
Tel. +52-55-3601 9500

www.abb.com/substationautomation