

We reserve all rights in this document and in the information contained therein. Reproduction, use or disclosure to third parties without express authority is strictly forbidden. Copr. ABB AB

### Table of contents

Part of product	Sheet
Designation for 6U, 1/2x19" casing with 1 TRM slot	2
Communication module (COM)	3
Power supply module 48–125 VDC (PSM)	4
Power supply module 110–250 VDC, 100–240 VAC (PSM)	5
Transformer module (TRM)	6
Binary input/output module (BIO)	7
Binary input/output module (BIO)	8
Binary input/output module (BIO)	9
Binary input/output module (BIO)	10

Based on		Prepared 2010-05-12	Agneta Rydh	Title Connection Diagram		Doc.des.	Ref.des.	
		Approved 2011-12-08	Patrik Nyback	REC650 (3Ph/1CBAB) A02		Doc.kind		
		Project		IEC symbols		Resp.dept.	PSNX/TPLA	Rev.ind. B
				<b>ABB</b> ABB AB		Doc.No. 1MRK006501-CB		Lang. en
Rev	Rev. Note	Date	Name			Sheet 1		
1		2				Cont. 2		

We reserve all rights in this document and in the information contained therein. Reproduction, use or disclosure to third parties without express authority is strictly forbidden. Copr. ABB AB

1/2x19"

Rear view slot

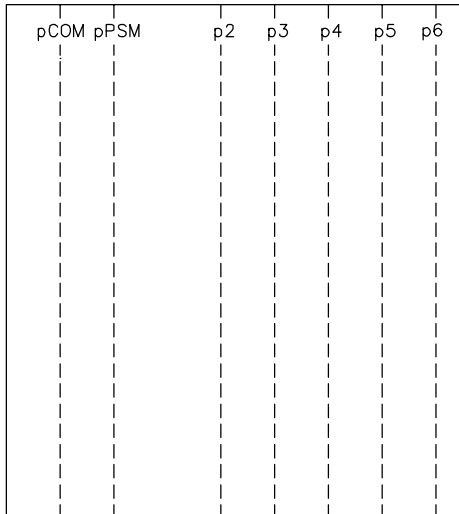

6U

Designation for 6U, 1/2x19" casing with 1 TRM

Module	Slot	Terminal
COM	pCOM	X0, X1, X4, X9, X304
PSM	pPSM	X307, X309, X410
TRM	p2	X101, X102
BIO	p3	X321, X324
BIO	p4	X326, X329
BIO	p5	X331, X334
BIO	p6	X336, X339

p= Position

Rear view terminal

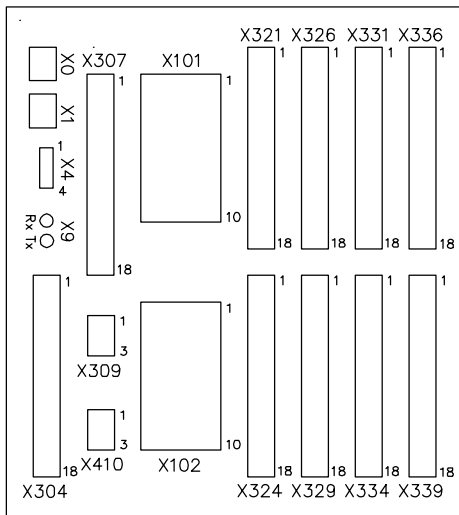

Based on		Prepared 2010-05-12	Agneta Rydh	Title Connection Diagram		Doc.des.	Ref.des.	
		Approved 2011-12-08	Patrik Nyback	REC650 (3Ph/1CBAB) A02		Doc.kind		
		Project		IEC symbols		Resp.dept.	PSNX/TPLA	Rev.ind. B
				<b>ABB</b> ABB AB		Doc.No. 1MRK006501-CB		Lang. en
Rev	Rev. Note	Date	Name			Sheet 2		
1		2				Cont. 3		

We reserve all rights in this document and in the information contained therein. Reproduction, use or disclosure to third parties without express authority is strictly forbidden. Copr. ABB AB

Communication module (COM)

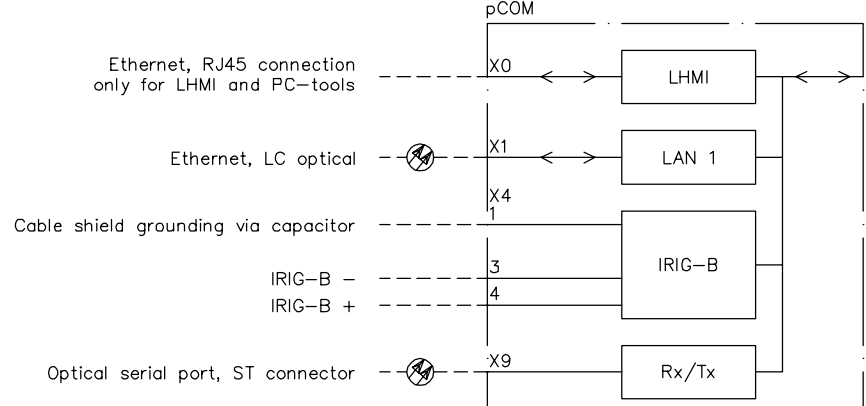

Observe polarity sequence of RL connectors

X304		CONFIGURATION
1	C1-4	
+ 2	BI01	// QA1_OPEN
+ 3	BI02	// QA1_CLOSE
+ 4	BI03	// QA1_SPR_CHRGD
+ 5	BI04	// QA1_SF6_LOW
+ 6	C5-8	
+ 7	BI05	// QB9_OPEN
+ 8	BI06	// QB9_CLOSED
+ 9	BI07	// QC9_OPEN
+ 10	BI08	// QC9_CLOSED
+ 11	C9-11	
+ 12	BI09	// BLOCK_CMD
+ 13	BI10	// SPARE
+ 14	BI11	// SPARE
+ 15	C12-14	
+ 16	BI12	// RESET_LOCKOUT
+ 17	BI13	// EXT_START_DR
+ 18	BI14	// ACTV_TESTMODE

Based on		Prepared 2010-05-12	Agneta Rydh	Title Connection Diagram		Doc.des.	Ref.des.	
		Approved 2011-12-08	Patrik Nyback	REC650 (3Ph/1CBAB) A02		Doc.kind		
		Project		IEC symbols		Resp.dept.	PSNX/TPLA	Rev.ind. B
								Lang. en
Rev	Rev. Note	Date	Name	<b>ABB</b>		Doc.No. 1MRK006501-CB		Sheet 3
1		2						Cont. 4

We reserve all rights in this document and in the information contained therein. Reproduction, use or disclosure to third parties without express authority is strictly forbidden. Copr. ABB AB

### Power supply module 48–125 VDC (PSM)

pPSM

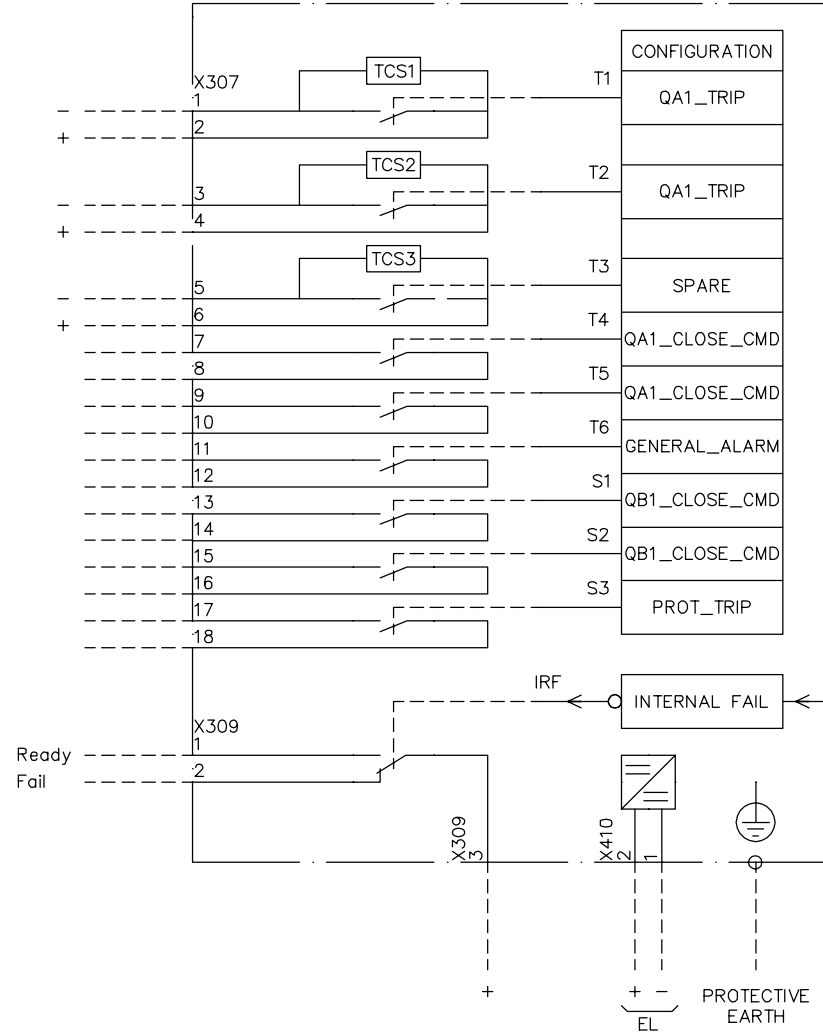

Observe polarity sequence

Based on		Prepared 2010-05-12	Agneta Rydh	Title Connection Diagram		Doc.des.	Ref.des.	
		Approved 2011-12-08	Patrik Nyback	REC650 (3Ph/1CBAB) A02		Doc.kind		
		Project		IEC symbols		Resp.dept.	PSNX/TPLA	Rev.ind. B
								Lang. en
Rev	Rev. Note	Date	Name	<b>ABB</b>		Doc.No. 1MRK006501-CB		Sheet 4
1		2						Cont. 5

We reserve all rights in this document and in the information contained therein. Reproduction, use or disclosure to third parties without express authority is strictly forbidden. Copr. ABB AB

### Power supply module 110–250 VDC, 100–240 VAC (PSM)



Observe polarity sequence

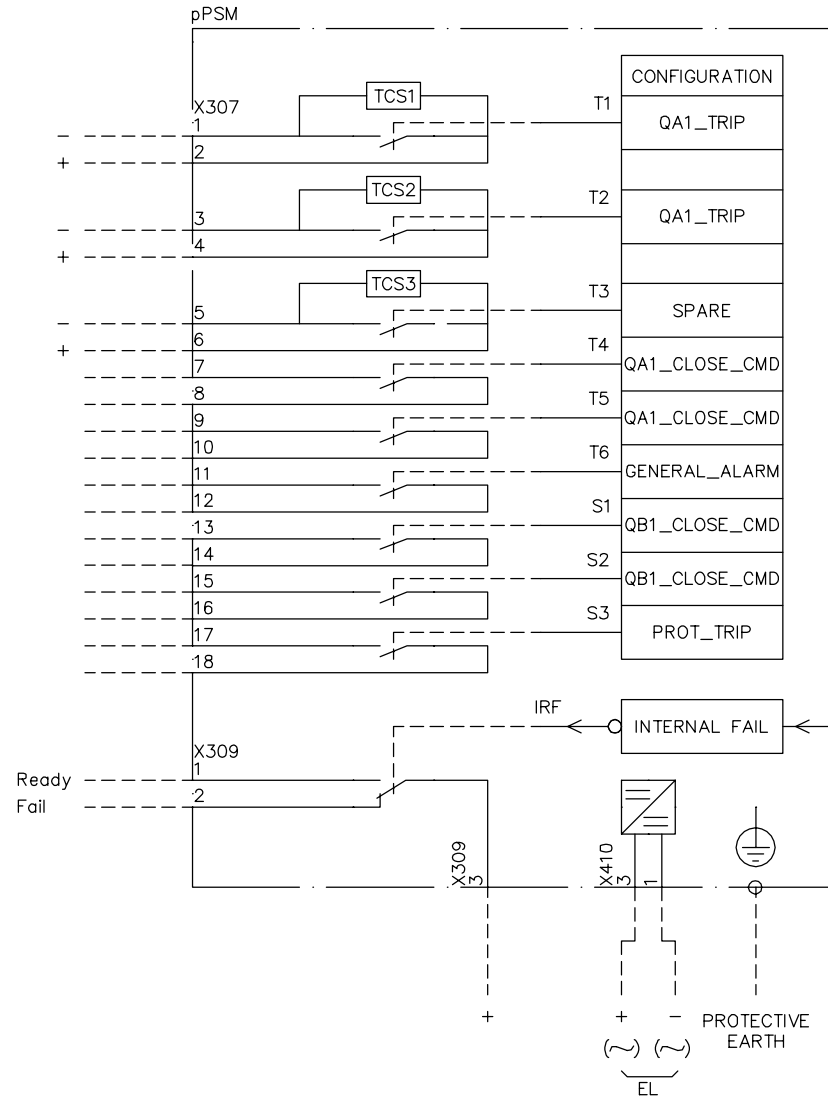

Based on		Prepared 2010-05-12		Agneta Rydh		Title Connection Diagram		Doc.des.		Ref.des.	
		Approved 2011-12-08		Patrik Nyback		REC650 (3Ph/1CBAB) A02		Doc.kind			
		Project				IEC symbols		Resp.dept. PSNX/TPLA		Rev.ind. B Long. en	
Rev		Rev. Note		Date		Name		Doc.No. 1MRK006501-CB		Sheet 5	
1		2		3		4		7		Cont. 6	



ABB AB

We reserve all rights in this document and in the information contained therein. Reproduction, use or disclosure to third parties without express authority is strictly forbidden. Copr. ABB AB

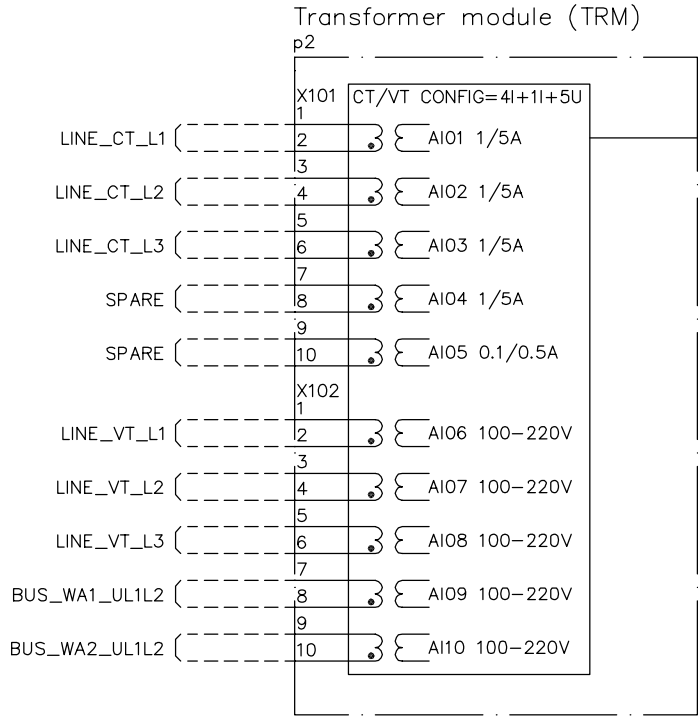

Compression or ringlug terminals

- Indicates high polarity. Note that internal polarity can be adjusted by setting of analog input CT neutral direction and or on SMAI pre-processing function blocks.

Based on		Prepared 2010-05-12	Agneta Rydh	Title Connection Diagram REC650 (3Ph/1CBAB) A02 IEC symbols	Doc.des.	Ref.des.	
		Approved 2011-12-08	Patrik Nyback		Doc.kind		
		Project		Resp.dept.	PSNX/TPLA	Rev.ind.	B Long. en
Rev	Rev. Note	Date	Name	<b>ABB</b> ABB AB		Doc.No. 1MRK006501-CB	
1		2				Sheet 6	

We reserve all rights in this document and in the information contained therein. Reproduction, use or disclosure to third parties without express authority is strictly forbidden. Copr. ABB AB

### Binary input/output module (BIO)

p3

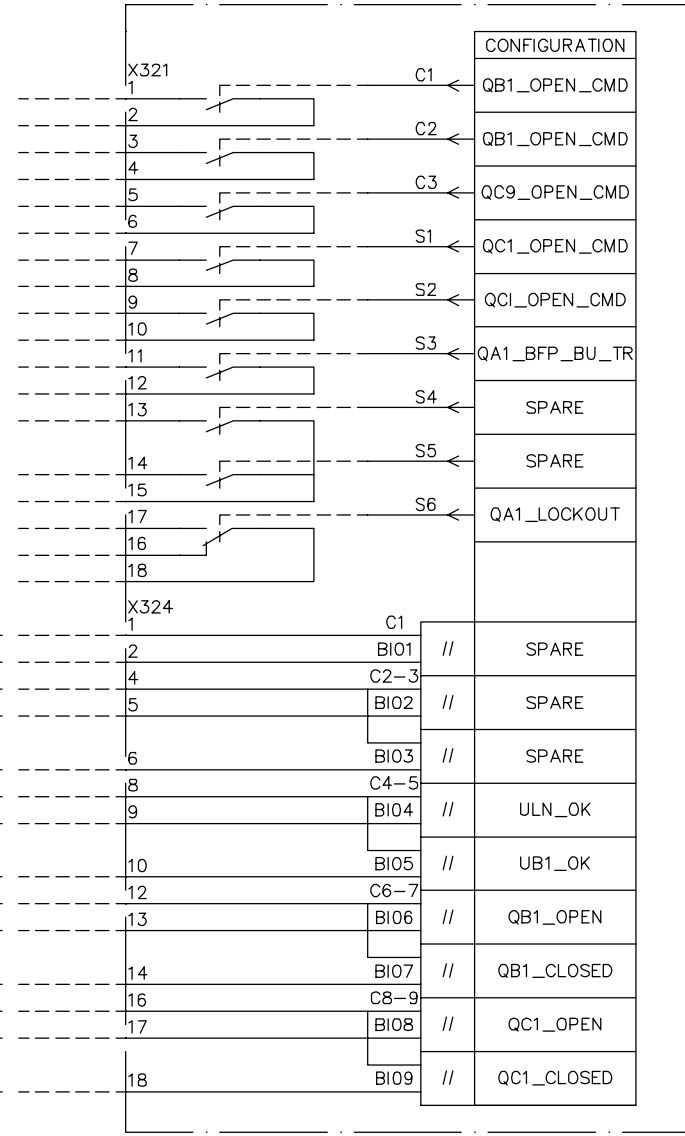

Observe polarity sequence of RL connectors

RL

Based on		Prepared 2010-05-12	Agneta Rydh	Title Connection Diagram		Doc.des.	Ref.des.	
		Approved 2011-12-08	Patrik Nyback	REC650 (3Ph/1CBAB) A02		Doc.kind		
		Project		IEC symbols		Resp.dept.	PSNX/TPLA	Rev.ind. B
				<b>ABB</b>		1MRK006501-CB		Lang. en
Rev	Rev. Note	Date	Name			Doc.No.		
1		2		3	4	5	6	8

We reserve all rights in this document and in the information contained therein. Reproduction, use or disclosure to third parties without express authority is strictly forbidden. Copr. ABB AB

### Binary input/output module (BIO)

p4

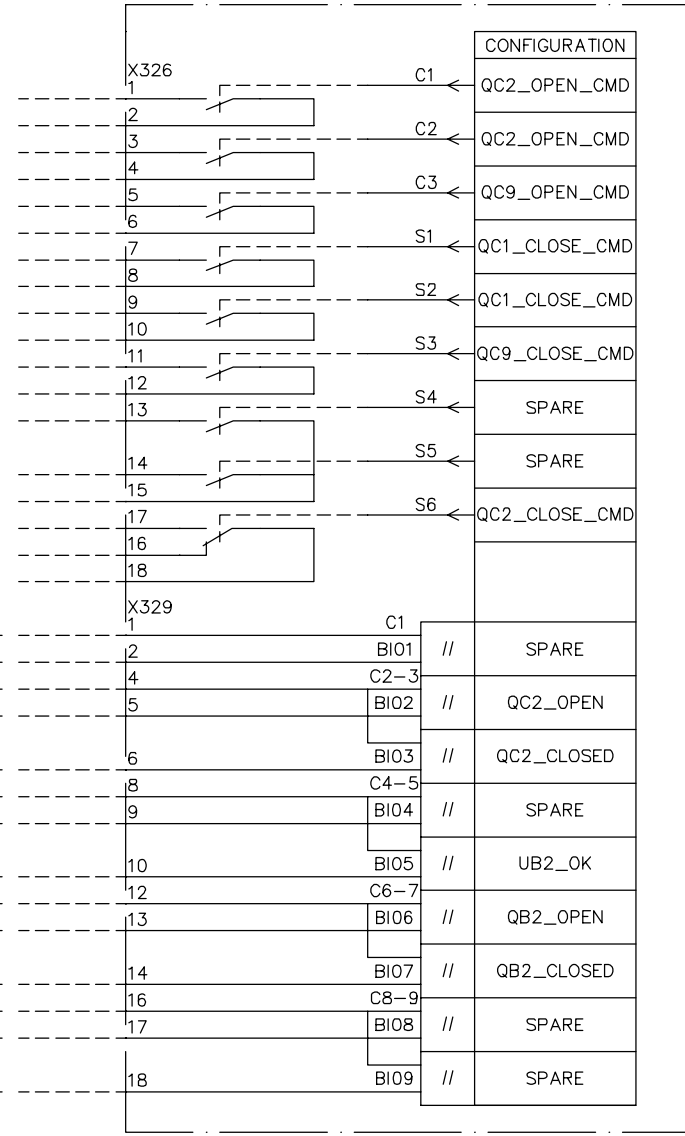

Observe polarity sequence of RL connectors

RL

Based on		Prepared 2010-05-12	Agneta Rydh	Title Connection Diagram		Doc.des.	Ref.des.	
		Approved 2011-12-08	Patrik Nyback	REC650 (3Ph/1CBAB) A02		Doc.kind		
		Project		IEC symbols		Resp.dept.	PSNX/TPLA	Rev.ind. B
				<b>ABB</b>		1MRK006501-CB		Lang. en
Rev	Rev. Note	Date	Name			Doc.No.		
1		2		3		7		Cont. 9

We reserve all rights in this document and in the information contained therein. Reproduction, use or disclosure to third parties without express authority is strictly forbidden. Copr. ABB AB

### Binary input/output module (BIO)

p5

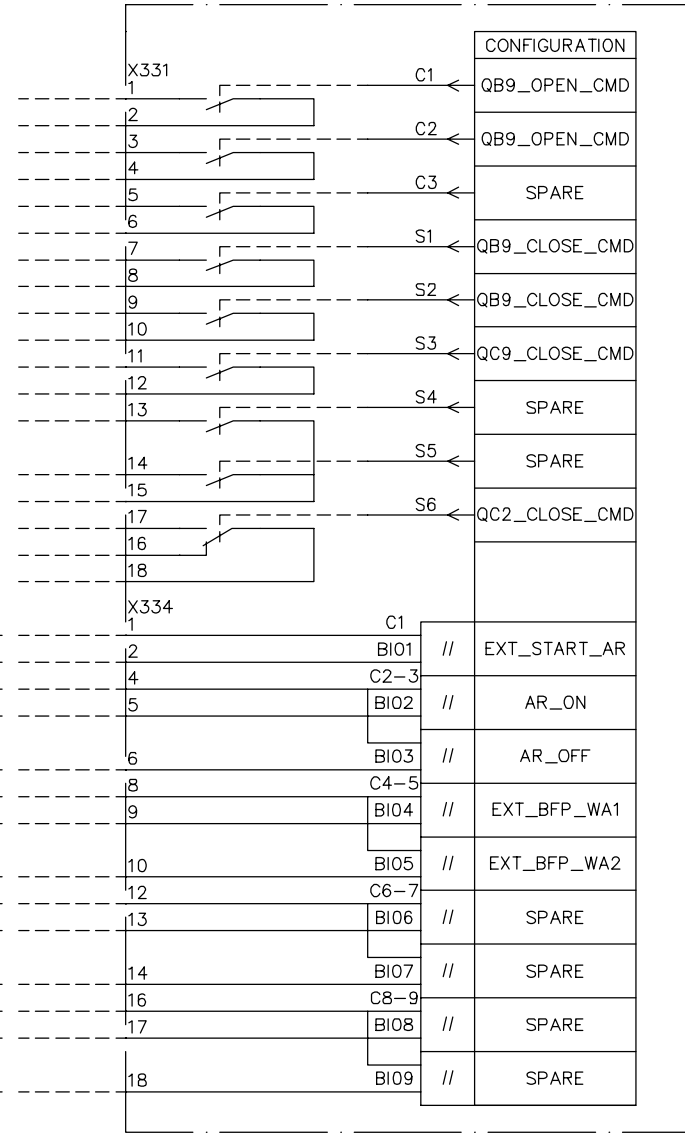

Observe polarity sequence of RL connectors

RL

Based on		Prepared 2010-05-12	Agneta Rydh	Title Connection Diagram		Doc.des.	Ref.des.	
		Approved 2011-12-08	Patrik Nyback	REC650 (3Ph/1CBAB) A02		Doc.kind		
		Project		IEC symbols		Resp.dept.	PSNX/TPLA	Rev.ind. B
				<b>ABB</b>		1MRK006501-CB		Lang. en
Rev	Rev. Note	Date	Name			ABB AB	Doc.No.	Sheet 9

We reserve all rights in this document and in the information contained therein. Reproduction, use or disclosure to third parties without express authority is strictly forbidden. Copr. ABB AB

### Binary input/output module (BIO)

p6

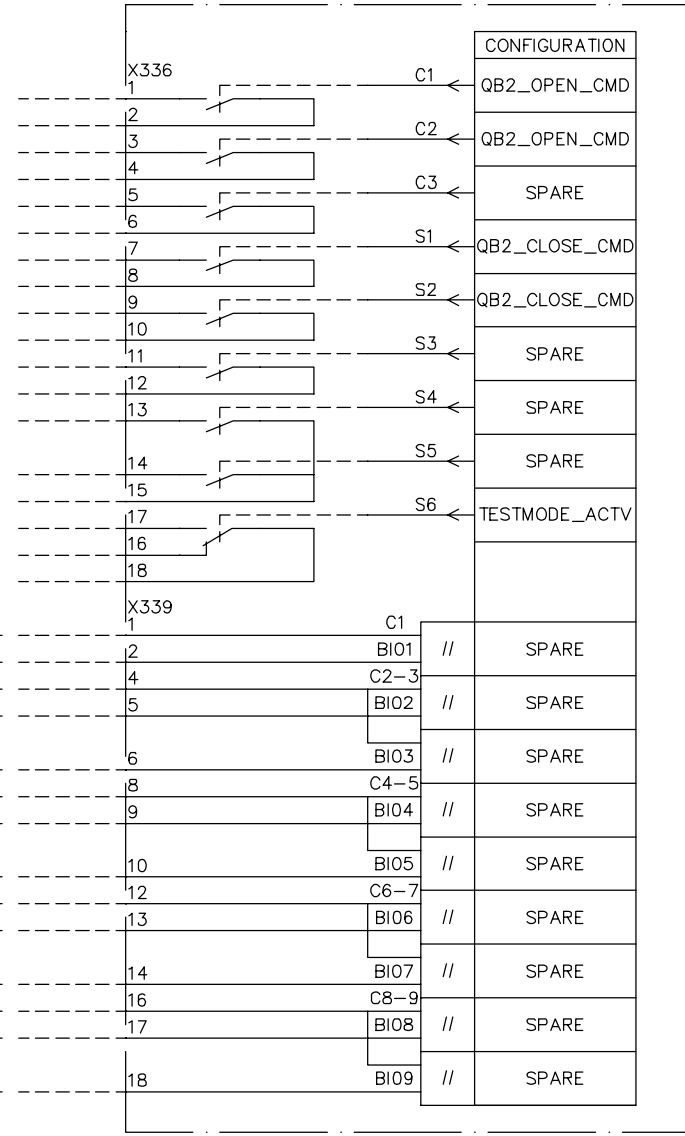

Observe polarity sequence of RL connectors

RL

Based on		Prepared 2010-05-12	Agneta Rydh	Title Connection Diagram		Doc.des.	Ref.des.	
		Approved 2011-12-08	Patrik Nyback	REC650 (3Ph/1CBAB) A02		Doc.kind		
		Project		IEC symbols		Resp.dept.	PSNX/TPLA	Rev.ind. B
								Lang. en
Rev	Rev. Note	Date	Name	<b>ABB</b>		Doc.No. 1MRK006501-CB		Sheet 10
1		2						Cont. -