

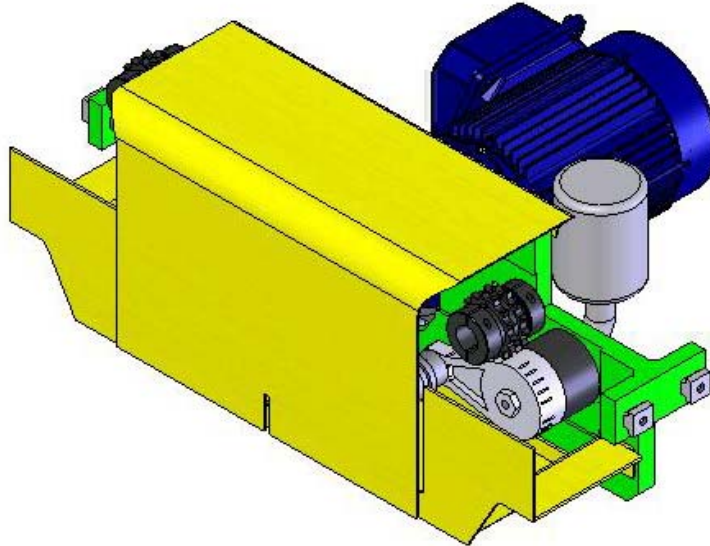

# MS-7 Metric Conveyor Drive – 600mm

Main Applications: Transport Drive for MS-7 Conveyor



**Description:**

- Motor gearbox that drives the MS-7 conveyor

**Equipment:**

- 1 HP Integral gear motor
- Double-strand chain and sprocket
- Automatic chain tensioner
- Automatic lubricator
- Safety enclosure

**Customer Benefits:**

- High operational safety
- Low total cost
- Low noise level
- Lubricated and tensioned drive chains provide long life
- Low maintenance

**Global Code:**

S0700-110-60

Version: A



# MS-7 Conveyor Drive – 600mm

## Process Parameters

Name	Values	Units	Description
Drive ratios:	43:1 (default); 121:1 (min); 29:1 or 35:1 (max);		
Speed	15 (default); 2 (min); 18 (max);	Meters / minute	Operating speed limits of the drive unit

## Design Parameters

Name	Values	Units	Description
Roller spacing	250 (default)	mm	Minimum roller space to package drive

### Reference Projects:

301137; 301152; 301171; 301172; 301174; 301174; 301200; 301217; 301216; 301243; 301228; 301229; 301239; 301351; 301359; 301364

ABB Inc.  
1250 Brown Road  
Auburn Hills, Michigan 48326  
T/ 248-393-4600  
F/ 248-393-4603

ABB Automation Technologies AB  
Powertrain  
Omformargatan 18  
SE-72137 Västerås  
Sweden  
T/ +46-21-3600-400  
F/ +46-21-3600-450

ABB Engineering Ltd.  
31 Industrial Building  
Fu Te Dong San Road  
Waigaoqiao FTZ, Pudong  
Shanghai, P. R. China 200131  
T/ +86-21-6105-6666  
F/ +86-21-6105-6667

[www.abb.com/robotics](http://www.abb.com/robotics)

**ABB Inc.**

