

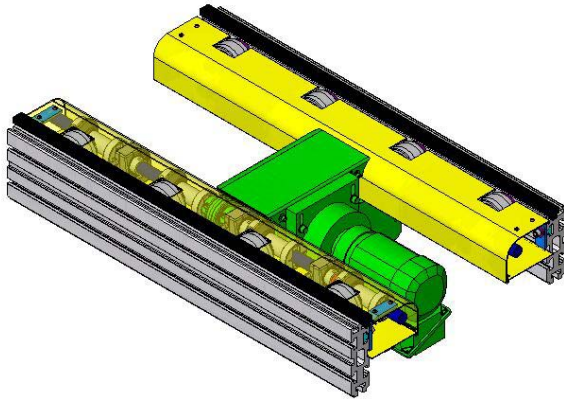

MS-7 Conveyor - 1 Meter Module

Main Applications: Palletized Transport



Description:

- Conveyor is used to transport pallets and parts. Axles, Engines and Transmissions

Equipment:

- Average weight distribution: 100 – 700 Kg
- Maximum pallet transport speed: 18 meters / minute
- Height to top of rollers: 300mm minimum
- 250mm roller spacing is standard with 1,000mm pitch (station to station)
- Roller spacing dependent upon pallet lengths and total weight
- Metric fasteners
- Option: ANSI versions are available
- Option: Positive drive roller for synchronous transfer
- Option: Transport integral manual lift gates
- Option: Transport swing gate modules

Customer Benefits:

- High operational safety
- Low total cost
- Low noise level
- Minimal controls expenses (modular system)
- High flexibility in use

Global Code:

S0700-100-10

Version: A



MS-7 Conveyor – 1 Meter Module

Process Parameters

Name	Values	Units	Description
Load	700 (max); n/a (default); 100 (min);	Kg	Transport load capacity of this conveyor
Roller pitch	200 (min); 250 (max); 250 (default);	mm	Pitch of the rollers
Height	300 (min); 550 or 800 (default); n/a (max);	mm	Height of conveyor from machine floor
Standard length	1	meters	Standard length
Modular lengths	1m (min); 1m, 2m, 3m (default); 3m (max); In steps of 1m (max);	meters	Modular lengths

Design Parameters

Name	Values	Units	Description
Speed	15 (default); 2 (min); 18 (max);	Meters/min	Operating speed limits of this conveyor
Delivery	10 (min); 12 (default); 18 (max);	weeks	Delivery time
Conveyor width	500 (min), 600 or 800 (default); 1000 (max);	mm	Pallet width
Span for legs design	2 meters, but this is variable based on surrounding equipment (default)	meters	Conveyor is supported by the legs with these spans.

Reference Projects:

301137; 301152; 301171; 301172; 301174; 301200; 301217; 301216; 301243; 301228; 301229; 301239; 301351; 301359; 301364

ABB Inc.
1250 Brown Road
Auburn Hills, Michigan 48326
T/ 248-393-4600
F/ 248-393-4603

ABB Automation Technologies AB
Powertrain
Omformargatan 18
SE-72137 Västerås
Sweden
T/ +46-21-3600-400
F/ +46-21-3600-450

ABB Engineering Ltd.
31 Industrial Building
Fu Te Dong San Road
Waigaoqiao FTZ, Pudong
Shanghai, P. R. China 200131
T/ +86-21-6105-6666
F/ +86-21-6105-6667

www.abb.com/robotics

ABB Inc.

