

# System 800xA with AC 870P

We like it large



**ABB**

# Contents

	Page		Page
Industrial IT – from the field to control level	3	Operator Interface	12
System 800xA with AC 870P	4	Open system architecture	12
System architecture	6	Graphical representation and process control	12
Automation with highly reliable controllers	8	Integration of Aspects Objects™	13
PROFIBUS as an integrated solution	8	Control System Evolution	13
Fully integrated PROFIBUS engineering	9	<b>Comprehensive customer service</b>	<b>14</b>
AC 870P I/O modules	9	Global presence – consistent processes	14
<b>Efficient engineering, configuration, maintenance, and diagnostics</b>	<b>10</b>	Efficient service structure	14
Functional planning – a must for cross-system engineering	10	Trends in technology – Industrial IT	14
FDT/DTM – the integrated solution for PROFIBUS engineering and HART engineering	11	Pro-active service creates added value	14
The same engineering for PROFIBUS devices as for AC 870P Rack I/O	11		

# From the field to control level: System 800xA for AC 870P offers seamless information integration



Traditional process control systems achieved high process availability, reliability, and process quality. In today's business environment, our customers have a need for continuous productivity improvements to keep their competitiveness in the market. ABB's System 800xA with AC 870P paves the way to reach that goal. System 800xA with AC 870P is a proven process control system for demanding applications in various industries.

The wide range of the AC 870P Controller references includes power stations, petrochemicals, chemicals, food and beverages and many more. System 800xA with AC 870P's scalable redundancy throughout your whole system enables ultimate process availability. The powerful AC 870P controllers are networked via a redundant bus system. In addition, they constitute the links to I/O modules, field devices, operator stations, and engineering tools. System 800xA with AC 870P as the evolution of our proven DCS Symphony Melody is not only a well established control system, but is continuously improved and enhanced to increase our customers competitiveness. System 800xA with AC 870P perfectly protects our customers investments by combining the AC 870P process control system for large installations with the Extended Automation System 800xA featuring best-in-class productivity enhancement software such as 800xA Operations or 800xA Information Management.

## Overview

The main functionality of a process control system is to ensure the safe, intended and economic operation of the underlying process with an ultimate stability, reliability and availability. Besides this core functionality, System 800xA with AC 870P provides additional information on the state of process related assets and electrical devices to seamlessly integrate the process into your enterprise information management.

To efficiently build the control infrastructure, the engineering tool Composer for AC 870P with its intuitive multi-user interface supports the entire DCS lifecycle from planning, engineering, commissioning and maintaining your process information management.

The ABB Aspect Objects technology enables you to access the right information wherever and whenever you need it. In this process, System 800xA with AC 870P asset management tools help you to operate equipment, plant components, or even entire plants at their maximum performance.

## Openness

Using open, standardized interfaces, you can connect all sorts of systems from third-party suppliers, such as SAP R/3, CAE-, Web-based tools, or plant optimization tools.

# System 800xA with AC 870P

System 800xA's AC 870P controller is proven by thousands of successful applications worldwide and has established itself as a modular, open, and future-oriented process control system for any market and their specific requirements. System 800xA with AC 870P provides enterprise-wide support for different platforms, applications, and services required for modern process automation.

Enjoy reading this brochure to obtain information about the ABB System 800xA with AC 870P components and performance.

## Powerful system packages

The multi-level architecture of System 800xA with AC 870P is based on a combination of system packages – Controller and I/O, Engineering Tool, Operator Interface – and optional packages such as system-integrated solutions for process optimization or batch processes.

### • 800xA Operations

800xA Operations provides a consistent method for accessing enterprise-wide data and for interacting with multiple applications from connected workstation in the plant or office. It offers an intuitive system interface with a single window for navigating, accessing, and viewing plant information in real time to facilitate the right business decisions and actions to maximize productivity.

System 800xA gathers information from multiple plant sources and transforms it into relevant information for a diverse set of users such as maintenance technicians, process engineers, production managers or plant operators. Contextual navigation presents the entire production facility in a single window for these users.

### • AC 870P Composer

AC 870P Composer ties the efficient engineering, maintenance, and diagnostics functionality together into one integral package. AC 870P Composer supports the entire lifecycle of your project, starting from planning and engineering, commissioning to system documentation, release and upgrade.

AC 870P Composer with its extensive versioning capabilities supports concurrent engineering, delivery in lots and integrates with common CAE environments. With AC 870P Composer, we enable our customers to set up distributed environments with comprehensive multi user engineering capabilities.

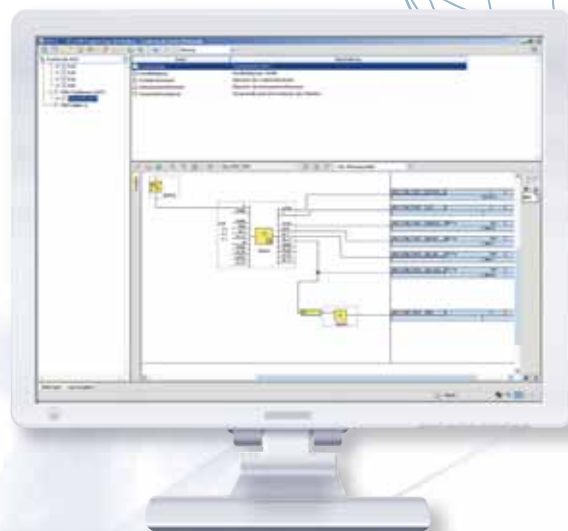

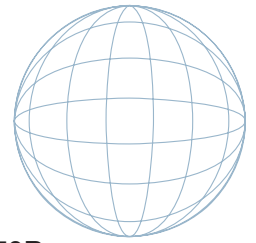

- **800xA Information Management**

Information is a key asset of all businesses. To achieve and maintain a sustainable competitive advantage, manufacturing and process businesses must be able to adapt quickly to change. Reduced time to decision and action is critical for improving quality and productivity.

800xA Information Management provides intelligent data access functions and views to both real-time and historical information from all applications in the extended automation system regardless of where it originated or is stored. Historical, process and business data are collected and transformed into meaningful information via a variety of straightforward customizable views and reports assisting all levels of personnel in making quick, informed decisions, to take the appropriate actions to improve efficiency and profitability.

- **800xA Batch Management**

800xA Batch Management is a comprehensive recipe management, batch and procedural control software. It provides the tools necessary to support the market's changing focus from traditional supervisory batch management to production management by supporting integrated production historian and production schedule interface for batch as well as procedural control applications in continuous and discrete processes.

800xA Batch Management with AC 870P supports existing Symphony Melody/SymBatch applications and thus paves the way for the direct evolution from ABB's successful SymBatch solution to the state-of-the-art 800xA Batch Management.



- **System 800xA Controller AC 870P and Rack mounted I/O**

The powerful System 800xA AC 870P controller family with its known sturdiness is made for demanding applications in large systems. With a maximum number of 250,000 I/O, System 800xA with AC 870P extends the range for possible applications far beyond usual plant sizes and thus provides our customers with a unique system scalability.

The whole system has been designed as fully redundant; nevertheless, our customers can downscale redundancy wherever wanted without additional effort - System 800xA with AC 870P internally manages any redundancy issues.

The comprehensive bus concept of the AC 870P controller allows for the easy integration of PROFIBUS and IEC 61850 electrical assets. The proven AC 870P rack mounted I/O provides you with an ultimate packing density that reduces the system demand for installation space.

The AC 870P hardware series provides the opportunity to be mounted in racks for centralized system topology or, in case of a distributed system architecture, to be mounted on rails. Additionally, S900 Remote I/O for use in hazardous areas, or S800 Remote I/O may be used.

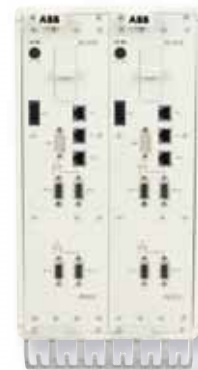

# System 800xA with AC 870P system architecture

800xA Operations  
800xA Batch Management  
800xA Asset Optimization  
800xA Information Management

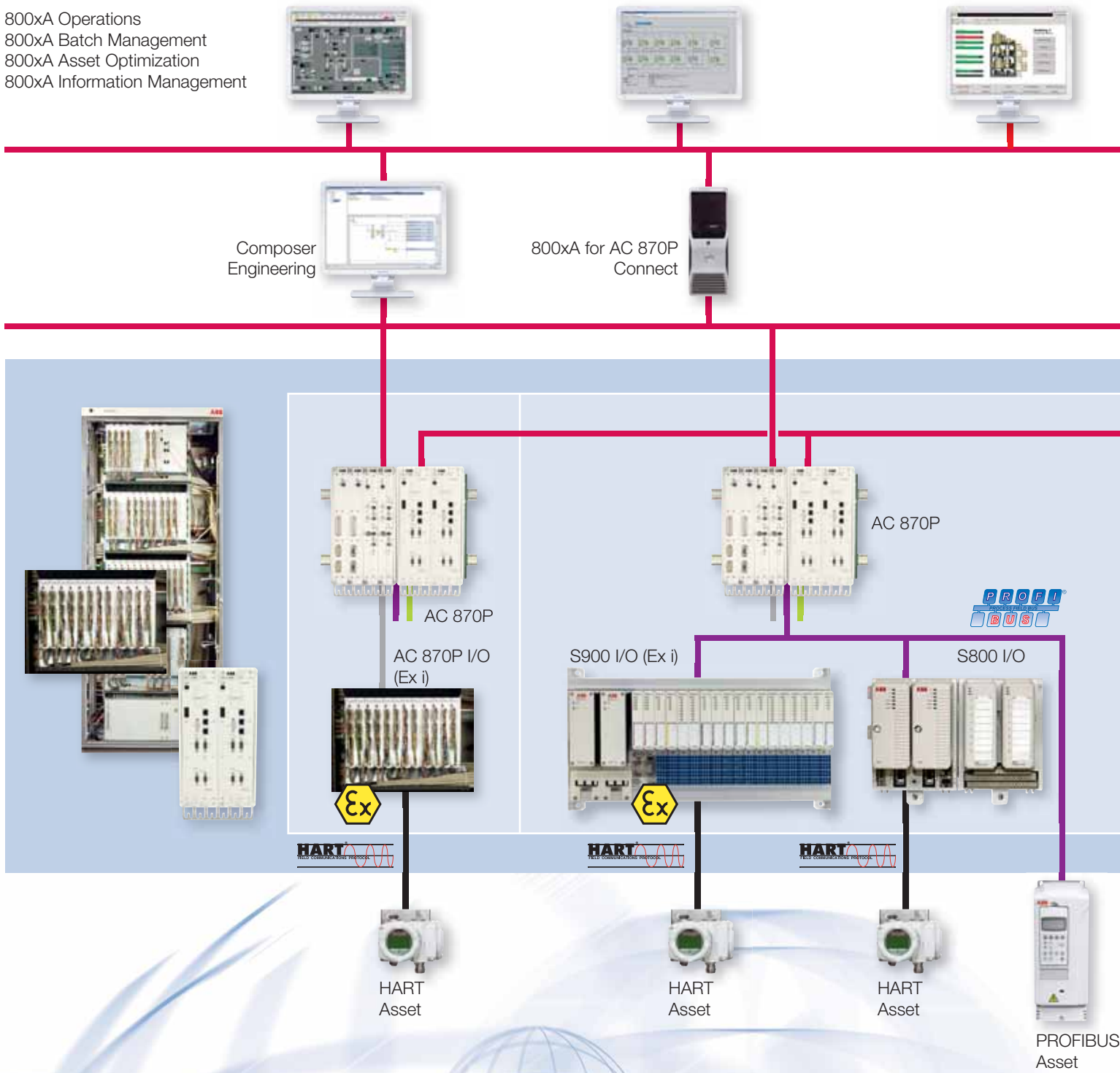



800xA Network

In designing the System 800xA with AC 870P system architecture, ABB Automation has created a basis for plug-and-play management. System 800xA with AC 870P has a unique network-oriented architecture, which offers seamless communication throughout all automation levels – from your process assets to plant-wide and multi-plant/multi-site information systems.

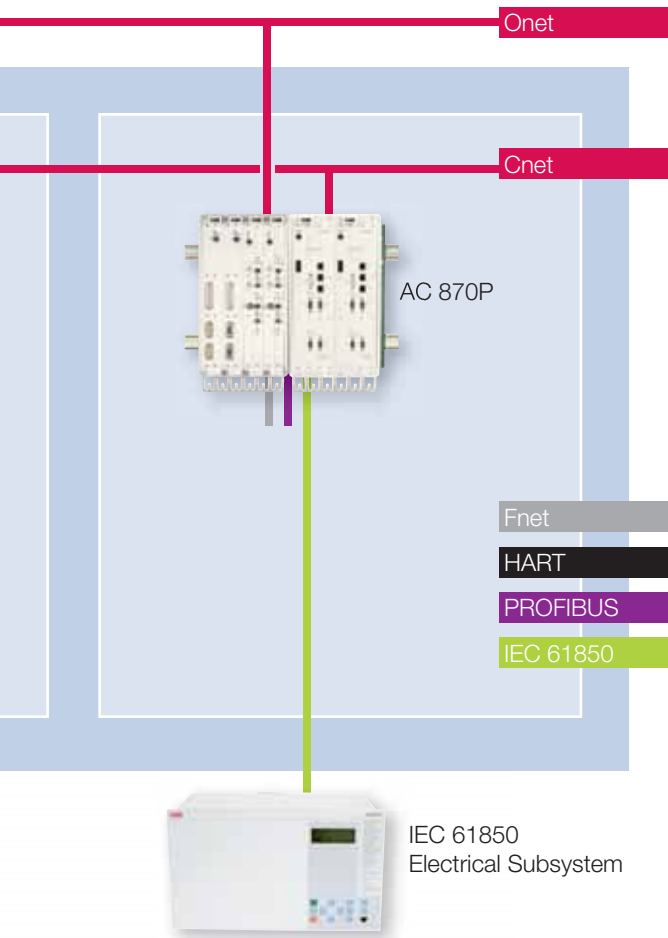

The control network strategy offers a high degree of freedom for communication in the entire operation, without neglecting the fundamental aspects of security and availability at process level. The network interconnects open system components. The communications technology is rugged and scalable and meets all the requirements for company-wide process management. With its 1ms time stamping within the entire system, System 800xA with AC 870P provides you with the complete Sequence of Events (SoE) in your plant history.

The new AC 870P controller PM876 widens the scope of System 800xA with AC 870P with a new, additional Ethernet interface for integration of electrical subsystems according to IEC 61850.

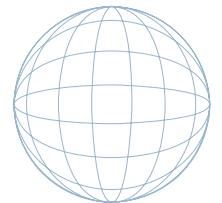

# System 800xA with AC 870P – automation with highly reliable controllers

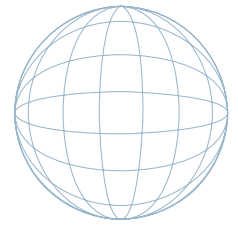

The AC 870P process stations are made up of modular high-performing AC 870P controllers, an entire range of I/O modules, and state-of-the-art fieldbus interfaces. For different markets and customer requirements you can choose from the rack or rail mounted versions of the AC 870P controller.

While the rack mounted AC 870P is optimized for ultimate I/O packing density in central cabinets, the rail mounted AC 870P is for preferably decentralized use within distributed system structures or fieldbus systems.

With a view to ensuring increased availability, both variants allow scalable system redundancy without the need for additional engineering work. The redundancy may vary from simple module redundancy to redundancy throughout the entire system. With the ABB Hot Configuration in Run (HCIR) functionality, that provides bumpless switchover in case of failure or hardware exchange, we also offer full redundancy coverage for your PROFIBUS assets.

## PROFIBUS as an integrated solution

In addition to the redundant interface for connecting the rack mounted AC 870P I/O modules, the AC 870P Controller provides two redundant PROFIBUS DP lines. The redundantly implemented PROFIBUS interfaces allow for redundant PROFIBUS field connections – for example, to System 800xA's remote I/O stations of the S800 and S900 series, that also provide redundant interface connections.

Non-redundant sections of the PROFIBUS Network can seamlessly be integrated using the RLM01 redundancy link module.



Controller  
AC 870P

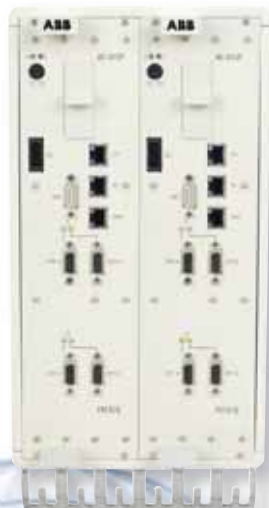

Redundancy  
Link Module  
RLM01

S800



S900



## Fully integrated PROFIBUS engineering

The efficient engineering environment of the AC 870P Composer provides you with a full fledged configuration suite for your PROFIBUS network. AC 870P Composer does not distinguish between rack mounted I/O devices and remote I/O that is connected via PROFIBUS. The underlying FDT/DTM interfaces allow you for plug-and-play integration of the connected field devices.

## AC 870P I/O modules

The proven AC 870P I/O system sets new standards for user convenience. You can combine the range of I/O modules as you wish in order to find the ideal solution for each specific application.



Properties of the AC 870P I/O modules include:

- I/O Module integrated intelligence provides extended functionality like error detection, alarm signaling, 1 ms time stamping and extensive system diagnostic functions
- Analog I/O process interface components provide a HART interface per channel
- Process interface components offer the option of an Ex i design
- Field signal connections on the front of the I/O modules for efficient usage of mounting space
- Maximum availability design by module integrated redundancy concepts
- The capability for operators to configure the system themselves without difficulty enables you to save both time and money. Calibration is not necessary.
- Hot-swap ability allows for module exchange in operation

# Efficient engineering, configuration, maintenance, and diagnostics during the whole plant lifecycle

Composer is the efficient multi user engineering environment for System 800xA with AC 870P. It simplifies configuration, documentation, commissioning, and maintenance along the entire lifecycle of your production.

Composer accompanies you from the definition of process points and loops, the functional planning of process control functions, the creation of the system structure and cabinet configuration to the fully integrated field device configuration for HART and PROFIBUS.

Composer also offers service and diagnostics functions for economical system configuration, documentation, commissioning, and maintenance.

Composer includes an extensive configuration management with versioning and handling of system upgrades.

Composer interfaces the Control System Engineering with the common CAE tools, including versioning and change management.

Composer supports distributed and concurrent engineering workflows and provides extensive support for delivery in lots.

Composer is the key component for the easy evolution from legacy systems on field, control and operations level.

## Functional planning – a must for cross-system engineering

The Composer engineering workflow is based on Function Block Diagrams and Sequential Function Charts as the main representation of the automation solution. The Function Block Diagram consists of a structured aggregation of base functionalities like a PID Controller or an I/O block. The function block itself is a view on the automation functionality as well as its representation in operations and plantwide information management systems. Thus, the function block diagram contains operating, monitoring, processing, or input/output functions and, if necessary, also field components. Function block diagrams as well as the hardware structure of the control system are structured in an underlying automation network. The automation network can be navigated within predefined views like the functional structure, the system structure or the location structure as well as in user defined views on smaller parts of the automation network. The relations between the networks elements can be directly navigated as well. Selecting the interesting cross reference from a context menu leads to the semantically connected network element. If you simply require a rough view of the automation functions, you can use general charts and area charts. Of course, you can switch from these to the corresponding detailed function charts.

Besides function block diagrams, Composer allows for the configuration of sequences with its IEC 61131-3 SFC editor. The Composer SFC editor automatically generates the required function charts, thus ensuring that the functional forward documentation is consistent. Any element of the SFC is part of the automation network as well and thus can be navigated with the same context oriented paradigm.

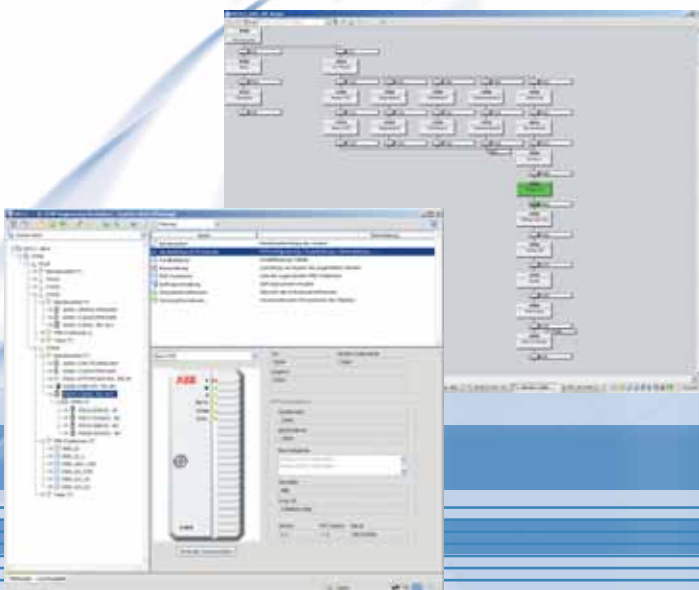

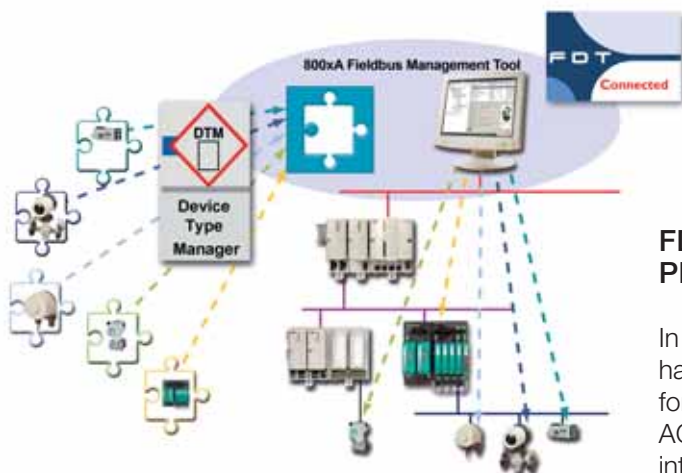

## FDT/DTM – the integrated solution for PROFIBUS / HART engineering

In integrating the PROFIBUS technology we have created a completely integrated solution for coupling field devices to System 800xA with AC 870P. The Field Device Tool interface (FDT) integrated into Composer allows you to configure, commission, and maintain PROFIBUS devices and HART devices intuitively and easily, aided by device-specific Device Type Managers (DTM), which are supplied by the respective device manufacturers, while standard DTMs are available for coupling devices without specific DTMs.

## IEC 61850 – integration of electrical sub-systems

With Composer version 5.1, IEC 61850 electrical subsystems are integrated into the Composer control engineering and 800xA Operations. Composer interfaces the intelligent electronic devices (IED) and allows for the integration of their Alarm and Event Handling, their I/O variables and state messages into System 800xA information management.

## The same engineering for PROFIBUS devices as for AC 870P Rack I/O

Once the device dependent specifications in the Composer Engineering System are known, the PROFIBUS device system is planned as for conventional AC 870P I/O devices simply using drag & drop.

The calling up of DTMs for configuration, online and offline parameterization, as well as measured-value representation in the field device itself works, as usual, using the various displays (function chart, system overview, etc.). Due to the planned system topology, the PROFIBUS master and devices are configured automatically in Composer. The device-specific data or the master data is likewise loaded automatically when the corresponding function charts are loaded.

All information required by the automation process or process control system can be accessed for specific objects via the function chart – e. g. using context menus – and can be called up by operators intuitively from the System 800xA operator workplace. In this way, you can not only call up Composer-specific data, which can be managed and kept consistent using an integrated database management system, but also use Composer to call up any external documents/applications for specific objects as well as their representations in operation.

For the integration of DCS engineering into the plant engineering workflow, Composer provides extensive bulk data functionalities for Microsoft® Office Excel and interfaces CAE Tools like Comos PT®. Any exchanged data is subject to the Composer versioning and quality assurance technologies.

### Particular properties of the Composer engineering system include

- Efficient engineering for instrumentation and control systems
- Function-oriented configuration, commissioning, and maintenance
- Functional CAE Tool Integration
- Delivery in lots
- Support for distributed concurrent engineering
- Multi User Engineering
- Integrated FDT/DTM field device configuration
- Integration of IEC 61850 electrical subsystems
- Integration of external documents and applications
- Consistent functional forward documentation
- Online and offline processing
- Project-specific libraries and macro technology
- Straightforward navigation and intuitive user guidance

# Operator Interface

System 800xA's operator interface 800xA Operations is one of the industry's most intuitive HSI for process management and operation.

The enabling technology for this data access, storage, and management is ABB's patented Aspect Object framework. Aspects are informational items associated with objects, such as I/O definitions, engineering drawings, process graphics, etc. that are assigned to each object in the system.

With the Aspect Objects Technology, 800xA Operations seamlessly includes the proven 800xA Asset Optimization and MES/ERP System connectivity into the system's HSI. The engineering and operator level of System 800xA with AC 870P also serves as a platform for S88-compliant and NAMUR-compliant batch and recipe administration.

## Open system architecture

The open architecture of 800xA Operations allows you to scale both, small and large distributed and redundant operator levels.

The System 800xA with 870P is entirely client/server-based. Thus, all dialogs are available on all clients and their use is only restricted by the rights of the respective user profiles in the system.

## Graphical representation and process control

The engineering and operator system has a modern graphical user interface and contains a clearly-structured working area in which:

- Alarms are signaled and events reported
- The actual operator dialogs are contained
- The navigation area for calling all objects is located

The engineering and operator system has a complete series of standard graphic displays, such as area displays, measured-value-specific faceplates, trend curves, and overview graphics. A user-friendly graphics editor is used to create the application-specific graphics and an extensive library of 2D and 3D symbols is provided. A system can contain a plenty of displays with both standard and custom graphics, also allowing you to include animations and video streams.

During engineering with the Composer, the basic operator interface is generated by simple upload into 800xA Operations. With this upload, faceplates, logs, trends, etc. are generated.

In this way, the DCS base functionality for an efficient commissioning is generated automatically in operations. Any changes in the functional structure are thus published into operations by simple upload.



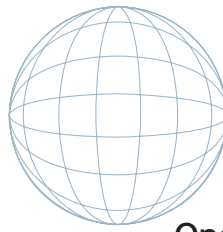

## Integration of Aspect Objects

In addition to the standard and custom graphics, the operator interface navigator also allows you to use applications and programs which are not part of the operator system itself but offer useful additional information. Thus, you can call up additional Aspects or information based on a measured value or an object of your choice within the operator interface.

Examples of such Aspects are:

- Group display
- Trend display
- Data sheet
- P&ID drawing
- Process instruction
- Images or video streams
- Asset optimization
- Quality system
- Internet pages

## Control System Evolution

As a world leading manufacturer of automation systems, we are obligated to protect our customers investments. System 800xA with AC 870P evolution capabilities offer an efficient and reasonable migration path from Contronic or Melody systems.

- Migration of Contronic P, E, 3 to System 800xA with AC 870P
- Migration of Maestro UX Operations
- Maestro UX and System 800xA Operations in parallel
- Evolution of SymBatch to 800xA Batch Management
- Online upgrade / No plant shutdown necessary
- Bumpless upgrade
- Migration Rack

## Operator Interface Navigator

The navigator ensures that all the displays are adjusted to meet the requirements of the window management. The window management also includes dialogs from other software such as Microsoft ® Office, Adobe Acrobat, or SAP R/3, which can be called up as Aspect views.

## Comprehensive archiving

The client/server architecture of the operator interface also contains a comprehensive archiving server, equipped with all the necessary functions, which captures and saves the following data:

- Trend data
- Events and alarms
- Files (i. e. reports)

## Alarm and message management

The operator interface has a powerful alarm and message management system which takes alarm and event messages from the process stations or generates them itself. For alarms and messages, according to your requirements, you can create and use your own:

- Area lines (areas)
- Message sequence lines (single messages)
- Status pages
- History pages

In addition to the configurable filters, users can set their own filters online within the defined framework and in this way analyze the events that are important for them.

Alarm/event group line



Alarm/event sequence line

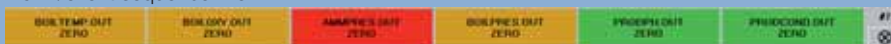

# Comprehensive customer service

## Global presence – consistent processes

Our service organization team of over 7,500 employees, with 100 years of experience in automation technology, supports our customers in more than 140 countries all over the world.

By making our services consistent and available throughout the world for leading industry products in process control, drive technology, and analysis technology as well as instrumentation, we are able to provide solutions to problems and respond to new demands extremely quickly.

## Efficient service structure

Service signifies a profitable investment in continually maximizing and optimizing the availability, quality, and security of a plant.

By structuring our organization into the following four areas:

- Customer Support Services
  - Training
  - Spare Parts & Logistics, Repair Shops
  - Process, Application & Consulting Services
- and through the resulting specialization of our employees, we guarantee maximum competence for each task we perform. Whether it's more traditional service support such as commissioning and maintenance or individual consultative services – the result is efficient and measurable customer benefit.

## Trends in technology – Industrial IT

New technological trends and developments have various effects on the automation of production processes and the associated demands regarding services. From networking various data flows to combining automation technology with modern information technology: ABB has the experience and know-how required to keep pace with these new demands. Using new communications capabilities such as remote services or the Internet and e-commerce brings customers real additional benefits for maximum availability and productivity.

## Pro-active service creates added value

Our comprehensive Life Cycle Services enable us to increase the value of your plant over its entire lifetime. The classical, reactive service can reduce production downtimes, while the use of new technologies offers an increased number of capabilities for preventive service measures to identify and avoid cost-intensive faults at an early stage.

Proactive service, such as asset management or ongoing modernization, increases the value of our customers' plants and gives them a distinct competitive edge.

Are you interested? Then get in touch with us to obtain more information about our wide range of services.



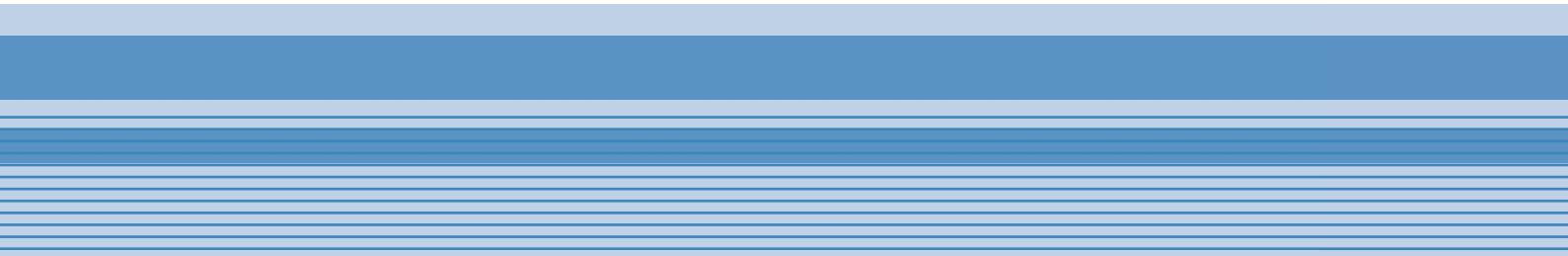

# System 800xA with AC 870P

We like it large



For additional information,  
please visit our Web pages at:

[www.abb.de/controlsystems](http://www.abb.de/controlsystems)



**ABB**  
**Process Automation Division**  
Mannheim, Germany  
Phone: +49 (0) 1805 266776  
Fax: +49 (0) 1805 776329  
[www.abb.de/controlsystems](http://www.abb.de/controlsystems)  
e-mail: [Marketing.Control-Products@de.abb.com](mailto:Marketing.Control-Products@de.abb.com)

**ABB**  
**Process Automation Division**  
Västerås, Sweden  
Phone: +46 (0) 21 34 20 00  
Fax: +46 (0) 21 13 78 45  
[www.abb.com/controlsystems](http://www.abb.com/controlsystems)  
e-mail: [processautomation@se.abb.com](mailto:processautomation@se.abb.com)

**ABB**  
**Process Automation Division**  
Wickliffe, Ohio, USA  
Phone: +1 440 585 8500  
Fax: +1 440 585 8756  
[www.abb.com/controlsystems](http://www.abb.com/controlsystems)  
e-mail: [industrialitsolutions@us.abb.com](mailto:industrialitsolutions@us.abb.com)

**ABB**  
**Process Automation Division**  
Singapore  
Phone: +65 6776 5711  
Fax: +65 6778 0222  
[www.abb.com/controlsystems](http://www.abb.com/controlsystems)  
e-mail: [processautomation@sg.abb.com](mailto:processautomation@sg.abb.com)

3BDD010071 en D

© Copyright 2008 ABB. All rights reserved.

The content is subject to change without prior notice. Pictures, diagrams, and other graphics in this document are simply provided for illustration and do not represent any product configurations or product functions. The user documentation supplied with the product is the sole source for descriptions of product functionality.

IndustrialIT, Aspect Objects, and all product names mentioned above in the form XXXXXX<sup>TM</sup> are registered or requested trademarks of ABB.

All rights to trademarks reside with their respective owners.