

Differential Protection for Power Transformers with RET 670

Application Example

SA2007-000029
November 22, 2006
Page 1 (14)

1	Introduction	1
2	RET 670 design principles	1
	2.1 Typical main CT connections for transformer differential protection	2
3	Application Examples with RET 670	3
	3.1 Star/wye-delta connected power transformer without tap changer	4
	3.2 Delta-star/wye connected power transformer without tap changer	7
	3.3 Wye-wye connected power transformer with on-load tap-changer and tertiary not loaded delta winding	10
4	Summary and conclusions	12

1 Introduction

Differential protection for power transformers has been used for decades. In order to correctly apply transformer differential protection proper compensation for:

- power transformer phase shift (i.e. vector group compensation)
- CT secondary currents magnitude difference on different sides of the protected transformer (i.e. ratio compensation)
- zero sequence current elimination (i.e. zero sequence current reduction)

shall be done. In the past this was performed with help of interposing CTs or special connection of main CTs (i.e. delta connected CTs). With numerical technology all these compensations are done in relay software.

This document will demonstrate how this compensation shall be done for RET 670.

2 RET 670 design principles

RET 670 is fully numerical device. Thus it is capable to provide differential protection for all standard three-phase power transformers without any interposing CTs. It has been designed with assumption that all main CTs will be star/wye connected. For such applications it is then only necessary to enter directly CT rated data and power transformer data as they are given on the power transformer nameplate and differential protection will automatically balance itself. However RET 670 can as well be used in applications where some of main CTs are connected in delta. In such cases the ratio for main CT connected in delta shall be intentionally set for $\sqrt{3}=1.732$ times smaller than actual ratio of individual phase CTs (e.g. instead of 800/5 set 462/5). At the same time the power transformer vector group shall be set as Yy0 because the RET 670 shall not internally provide any phase angle shift compensation. The necessary phase angle shift compensation will be provided externally by delta connected main CT. All other settings should have the same values irrespective of main CT connections. It shall be noted that irrespective of the main CT connections (i.e. star/wye or delta) on-line reading and automatic compensation for actual on-load tap-changer position can be used in RET 670.



2.1 Typical main CT connections for transformer differential protection

Three most typical main CT connections used for transformer differential protection are shown in Figure 1. It is assumed that the primary phase sequence is L1-L2-L3 (i.e. ANSI ABC).

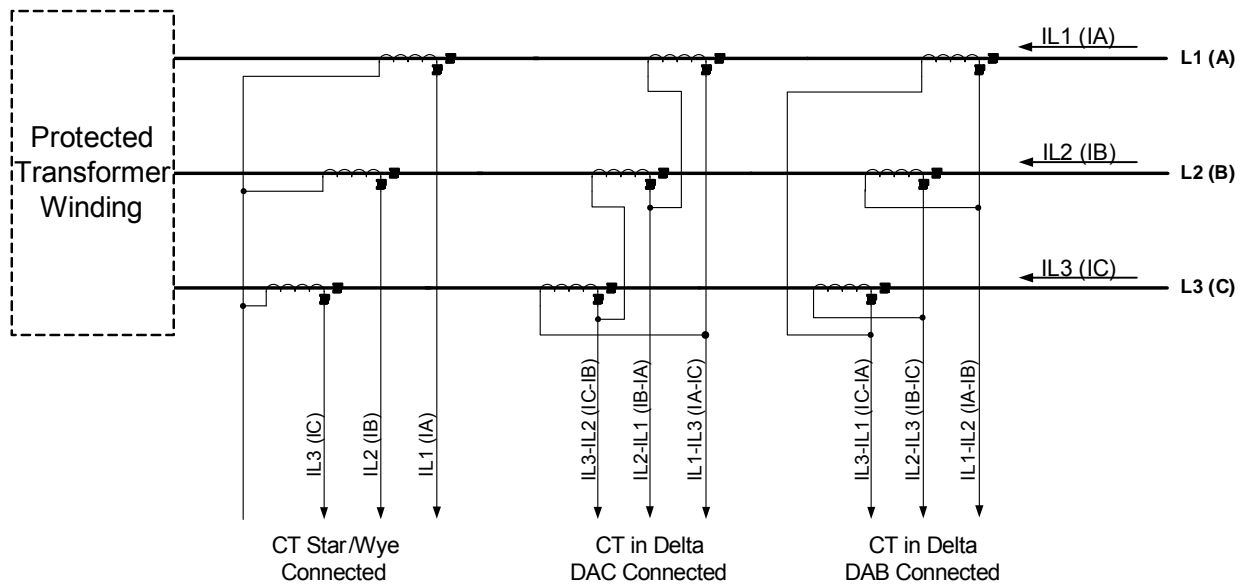

Figure 1: Commonly used main CT connections for Transformer Differential Protection

For star/wye connected main CTs, secondary currents fed to the differential relay:

- are directly proportional to the measured primary currents
- are in phase with the measured primary currents
- contain all sequence components including zero sequence current component

For star/wye connected main CTs, the main CT ratio shall be set in RET 670 as it is in actual application. The “StarPoint” parameter, for the particular star/wye connection shown in Figure 1, shall be set “ToObject”. If star/wye connected main CTs have their star point away from the protected transformer this parameter should be set “FromObject”.

For delta DAC connected main CTs, secondary currents fed to the differential relay:

- are increased $\sqrt{3}$ times (i.e. 1.732 times) in comparison with star/wye connected CTs
- lag for 30° the primary winding currents (i.e. this CT connection rotates currents for 30° in clockwise direction)
- do not contain zero sequence current component

For DAC delta connected main CT ratio shall be set for $\sqrt{3}$ times smaller in RET 670 than the actual ratio of individual phase CTs. The “StarPoint” parameter, for this particular connection shall be set “ToObject”. It shall be noted that delta DAC connected main CTs must be connected exactly as shown in Figure 1.

For delta DAB connected main CTs, secondary currents fed to the differential relay:

- are increased $\sqrt{3}$ times (i.e. 1.732 times) in comparison with star/wye connected CTs
- lead for 30° the primary winding currents (i.e. this CT connection rotates currents for 30° in anticlockwise direction)
- do not contain zero sequence current component

For DAB delta connected main CT ratio shall be set for $\sqrt{3}$ times smaller in RET 670 than the actual ratio of individual phase CTs. The “StarPoint” parameter, for this particular connection shall be set “ToObject”. It shall be noted that delta DAB connected main CTs must be connected exactly as shown in Figure 1.

For more detailed info regarding CT data settings please refer to the three application examples presented in Section 3.

3 Application Examples with RET 670

Three application examples will be given here. For each example two differential protection solutions will be presented:

- First solution will be with all main CTs star/wye connected
- Second solution will be with delta connected main CT on Y (i.e. star/wye) connected sides of the protected power transformer

For each differential protection solution the following settings will be given:

1. Input CT channels on the RET 670 TRM modules
2. General settings for the transformer differential protection where specific data about protected power transformer shall be entered

Finally the setting for the differential protection characteristic will be given which can be identical for all presented applications.

3.1 Star/wye-delta connected power transformer without tap changer

Single line diagrams for two possible solutions for such type of power transformer with all relevant application data are given in Figure 2.

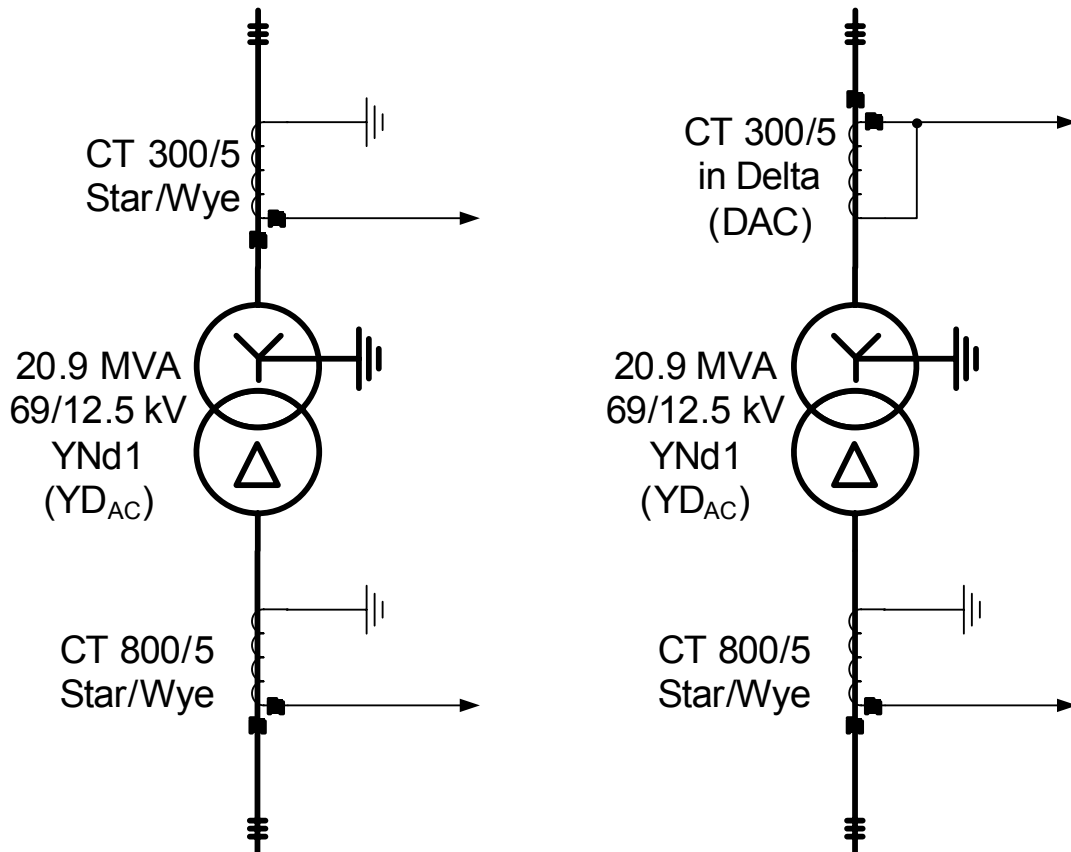

Figure 2: Two differential protection solutions for star/wye-delta connected power transformer

For this particular power transformer the 69kV side phase-to ground no-load voltages lead for 30° the 12.5kV side phase-to ground no-load voltages. Thus when external phase angle shift compensation is done by connecting main HV CTs in delta, as shown in the right-hand side in Figure 2, it must be ensured that the HV currents are rotated by 30° in clockwise direction. Thus the DAC delta CT connection must be used for 69kV CTs in order to put 69kV & 12.5kV currents in phase.

To ensure proper application of RET 670 for this power transformer it is necessary to do the following:

1. Check that HV & LV CTs are connected to 5A CT inputs in RET 670
2. For second solution make sure that HV delta connected CTs are DAC connected

3. For star/bye connected CTs make sure how they are stared (i.e. grounded) To/From protected transformer
4. Enter the following settings for all three CT input channels used for the LV side CTs

Setting Parameter	Selected Value for both Solutions
CTprim	800
CTsec	5
CTStarPoint	ToObject

5. Enter the following settings for all three CT input channels used for the HV side CTs

Setting Parameter	Selected Value for both Solution 1 (bye connected CT)	Selected Value for both Solution 2 (delta connected CT)
CTprim	300	$\frac{300}{\sqrt{3}} = 173$ ¹⁾
CTsec	5	5
CTStarPoint	FromObject	ToObject

¹⁾ To compensate for delta connected CTs

6. Enter the following values for the general settings of the differential protection function

Setting Parameter	Selected Value for both Solution 1 (bye connected CT)	Selected Value for both Solution 2 (delta connected CT)
RatedVoltageW1	69 kV	69 kV
RatedVoltageW2	12.5 kV	12.5 kV
RatedCurrentW1	175 A	175 A
RatedCurrentW2	965 A	965 A

ConnectTypeW1	WYE (Y)	WYE (Y)
ConnectTypeW2	delta=d	wye=y ¹⁾
ClockNumberW2	1 [30 deg lag]	0 [0 deg] ¹⁾
ZSCurrSubtrW1	On	Off ²⁾
ZSCurrSubtrW2	Off	Off
TconfigForW1	No	No
TconfigForW2	No	No
LocationOLTC1	Not Used	Not Used
Other Parameters	Not relevant for this application. Use default value.	Not relevant for this application. Use default value.

¹⁾ To compensate for delta connected CTs

²⁾ Zero-sequence current is already removed by connecting main CTs in delta

3.2 Delta-star/wye connected power transformer without tap changer

Single line diagrams for two possible solutions for such type of power transformer with all relevant application data are given in Figure 3.

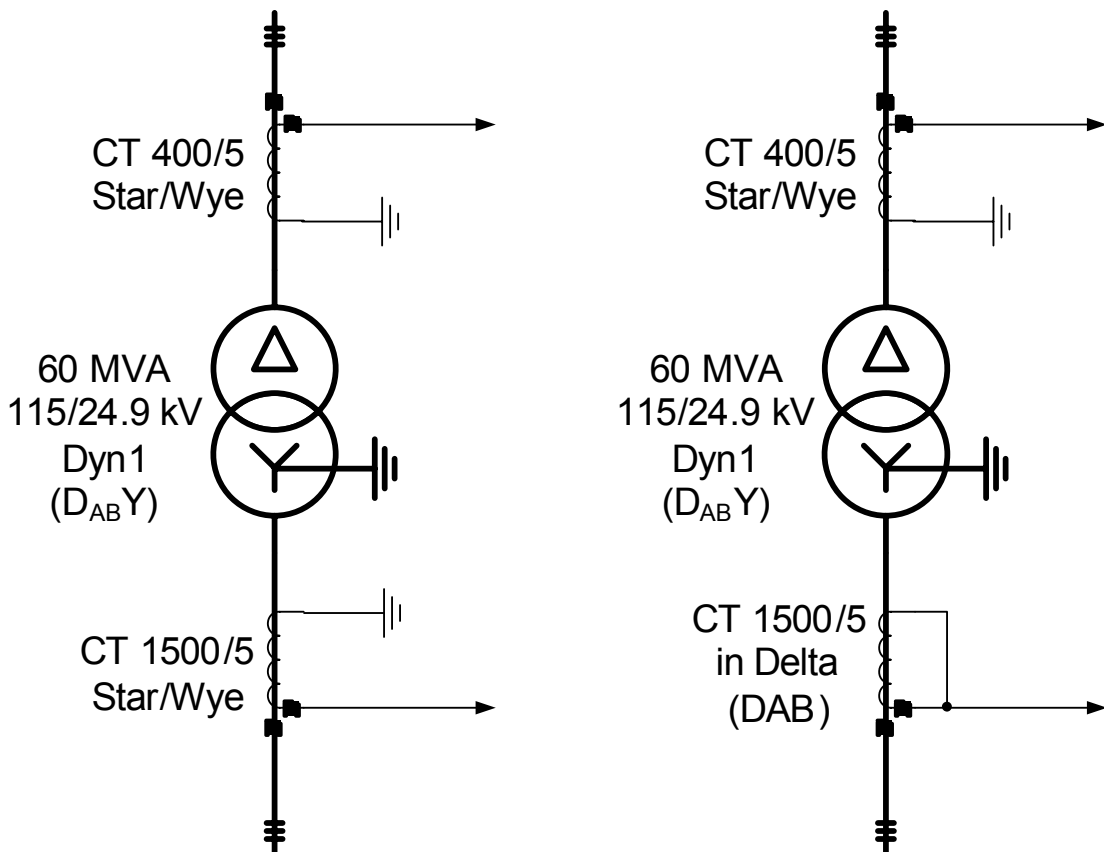

Figure 3: Two differential protection solutions for delta-star/wye connected power transformer

For this particular power transformer the 115kV side phase-to-ground no-load voltages lead for 30° the 24.9kV side phase-to-ground no-load voltages. Thus when external phase angle shift compensation is done by connecting main 24.9kV CTs in delta, as shown in the right-hand side in Figure 3, it must be ensured that the 24.9kV currents are rotated by 30° in anticlockwise direction. Thus, the DAB CT delta connection (see Figure 1) must be used for 24.9kV CTs in order to put 115kV & 24.9kV currents in phase.

To ensure proper application of RET 670 for this power transformer it is necessary to do the following:

1. Check that HV & LV CTs are connected to 5A CT inputs in RET 670
2. For second solution make sure that LV delta connected CTs are DAB connected
3. For star/wye connected CTs make sure how they are starred (i.e. grounded) To/From protected transformer

4. Enter the following settings for all three CT input channels used for the HV side CTs

Setting Parameter	Selected Value for both Solutions
CTprim	400
CTsec	5
CTStarPoint	ToObject

5. Enter the following settings for all three CT input channels used for the LV side CTs

Setting Parameter	Selected Value for both Solution 1 (wye connected CT)	Selected Value for both Solution 2 (delta connected CT)
CTprim	1500	$\frac{1500}{\sqrt{3}} = 866$ ¹⁾
CTsec	5	5
CTStarPoint	ToObject	ToObject

¹⁾ To compensate for delta connected CTs

6. Enter the following values for the general settings of the differential protection function

Setting Parameter	Selected Value for both Solution 1 (wye connected CT)	Selected Value for both Solution 2 (delta connected CT)
RatedVoltageW1	115 kV	115 kV
RatedVoltageW2	24.9 kV	24.9 kV
RatedCurrentW1	301 A	301 A
RatedCurrentW2	1391 A	1391 A
ConnectTypeW1	Delta (D)	WYE (Y) ¹⁾
ConnectTypeW2	wye=y	wye=y

ClockNumberW2	1 [30 deg lag]	0 [0 deg] ¹⁾
ZSCurrSubtrW1	Off	Off
ZSCurrSubtrW2	On	Off ²⁾
TconfigForW1	No	No
TconfigForW2	No	No
LocationOLTC1	Not Used	Not Used
Other Parameters	Not relevant for this application. Use default value.	Not relevant for this application. Use default value.

¹⁾ To compensate for delta connected CTs

²⁾ Zero-sequence current is already removed by connecting main CTs in delta

3.3 Wye-wye connected power transformer with on-load tap-changer and tertiary not loaded delta winding

Single line diagrams for two possible solutions for such type of power transformer with all relevant application data are given in Figure 4. It shall be noted that this example is applicable for protection of autotransformer with not loaded tertiary delta winding as well.

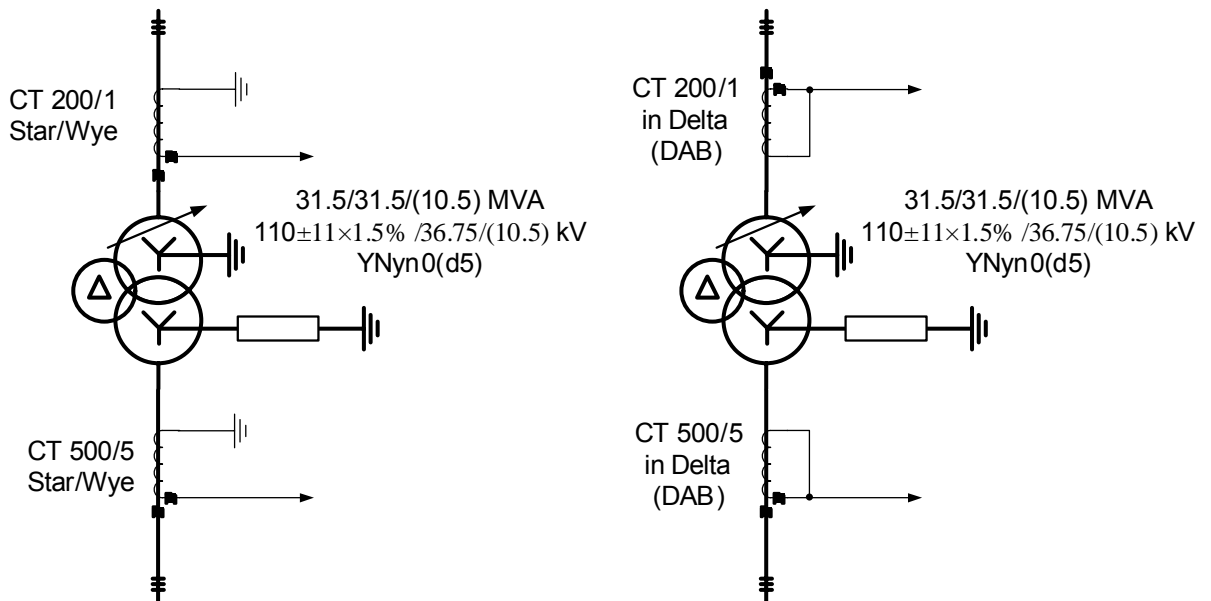

Figure 4: Two differential protection solutions for wye-wye connected transformer

For this particular power transformer the 110kV side phase-to ground no-load voltages are exactly in phase with the 36.75kV side phase-to ground no-load voltages. Thus, when external phase angle shift compensation is done by connecting main CTs in delta, both set of CTs must be identically connected (i.e. either both DAC or both DAB as shown in the right-hand side in Figure 4) in order to put 110kV & 36.75kV currents in phase.

To ensure proper application of RET 670 for this power transformer it is necessary to do the following:

1. Check that HV CTs are connected to 1A CT inputs in RET 670
2. Check that LV CTs are connected to 5A CT inputs in RET 670
3. When delta connected CTs are used make sure that both CT sets are identically connected (i.e. either both DAC or both DAB)
4. For wye connected CTs make sure how they are stered (i.e. grounded) towards or away from the protected transformer
5. Enter the following settings for all three CT input channels used for the HV side CTs

Setting Parameter	Selected Value for both Solution 1 (wye connected CTs)	Selected Value for both Solution 2 (delta connected CTs)
CTprim	200	$\frac{200}{\sqrt{3}} = 115$ ¹⁾
CTsec	1	1
CTStarPoint	FromObject	ToObject

6. Enter the following settings for all three CT input channels used for the LV side CTs

Setting Parameter	Selected Value for both Solution 1 (wye connected)	Selected Value for both Solution 2 (delta connected)
CTprim	500	$\frac{500}{\sqrt{3}} = 289$ ¹⁾
CTsec	5	5
CTStarPoint	ToObject	ToObject

¹⁾ To compensate for delta connected CTs

7. Enter the following values for the general settings of the differential protection function

Setting Parameter	Selected Value for both Solution 1 (wye connected)	Selected Value for both Solution 2 (delta connected)
RatedVoltageW1	110 kV	110 kV
RatedVoltageW2	36.75 kV	36.75 kV
RatedCurrentW1	165 A	165 A
RatedCurrentW2	495 A	495 A
ConnectTypeW1	WYE (Y)	WYE (Y)
ConnectTypeW2	wye=y	wye=y

ClockNumberW2	0 [0 deg]	0 [0 deg]
ZSCurrSubtrW1	On	Off ¹⁾
ZSCurrSubtrW2	On	Off ¹⁾
TconfigForW1	No	No
TconfigForW2	No	No
LocationOLTC1	Winding 1 (W1)	Winding 1 (W1)
LowTapPosOLTC1	1	1
RatedTapOLTC1	12	12
HighTapPsOLTC1	23	23
TapHighVoltTC1	23	23
StepSizeOLTC1	1.5%	1.5%
Other Parameters	Not relevant for this application. Use default value.	Not relevant for this application. Use default value.



¹⁾ Zero-sequence current is already removed by connecting main CTs in delta

4 Summary and conclusions

RET 670 can be used for differential protection of three-phase power transformers with main CTs either wye or delta connected. However the relay has been designed with assumption that all main CTS are wye connected. However RET 670 can be used in applications where main CTs are delta connected. For such applications the following shall be kept in mind:

- 1) Ratio for delta connected CTs shall be set $\sqrt{3}=1.732$ times smaller than actual individual phase CT ratio
- 2) Power transformer vector group shall be typically set as Yy0 because the compensation for power transformer actual phase shift is provided by external delta CT connection
- 3) Zero sequence current is eliminated by main CT delta connection. Thus on sides where CTs are connected in delta the zero sequence current elimination shall be set to Off in RET 670

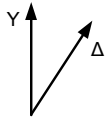
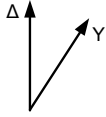
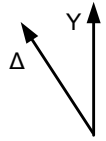
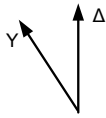
The following table summarizes the most commonly used wye-delta vector group around the world and provides information about required type of main CT delta connection on the wye sides of the protected transformer.

IEC Vector Group	ANSI Designation	Positive Sequence no-Load voltage phasor diagram	Required delta CT connection type on wye side of the protected power transformer and internal Vector Group setting in RET 670
YNd1	YD _{AC}		DAC / Yy0
Dyn1	D _{AB} Y		DAB / Yy0
YNd11	YD _{AB}		DAB / Yy0
Dyn11	D _{AC} Y		DAC / Yy0
YNd5	YD150		DAB / Yy6
Dyn5	DY150		DAC / Yy6

