

Use of 87T Relay Principles for Overall Differential Protection of Phase Angle Regulating Transformers

GAJIĆ, Z.* HOLST, S.
ABB AB, SA Products
Sweden

Summary

The flow of active power needs to be controlled in closely intermeshed networks as the 'natural' load flow resulting from the load conditions and existing line impedances is not necessarily the optimal load flow pattern. Another aspect of load flow control is the flexibility. A deregulated energy market requires flexible power system operation to ensure that the electricity supply contracts can be fulfilled. Technically, limitations on power transfer can always be removed by adding new transmission and/or generation capacity. However, FACTS devices are designed to remove such limitations and meet operators' goals without having to undertake major system investments.

One type of FACTS devices which can be used for active power flow control is phase angle regulating transformer. In today's power system two types of such transformer are used:

1. Phase Angle Regulating Transformers (PAR) [4], [5] are used to control the flow of electric power in a meshed power system. Both the magnitude and the direction of the power flow can be controlled by varying the phase angle shift across such series transformer. Traditionally on-load tap-changers are used to control this angle. Some modern additions to such transformers are possibility for thyristor control and/or connection in series with a controllable capacitor bank.
2. Variable Frequency Transformer (VFT) [7], [8] is based on a combination of hydro generator and a transformer. It consists of a rotary transformer, for continuously controllable phase angle shift, together with a drive system and control, which adjust the angle and speed of the rotary part, to regulate the power flow through the transformer. Such transformer provides a means to control power flow between two asynchronous grids (i.e. two power networks with different frequency).

Traditional 87T differential protection has been used for decades for overall differential protection of standard, three-phase power transformers. However use of 87T relays for overall differential protection of phase angle regulating transformers was considered impossible in presently used protective relaying standards and practices.

This paper will describe how 87T relay principle can be used for overall differential protection of any three-phase, Phase Angle Regulating Transformer or Variable Frequency Transformer. Such differential protection will be completely balanced for all types of external faults and through load conditions. At the same time it will be able to operate quickly for all internal faults. Such protection scheme will only need external, stand alone current transformers which will also eliminate any need for buried current transformers within the protected power transformer tank, as usually required by presently used protection schemes for phase angle regulating transformers [4], [5], [6]. Inrush stabilization (e.g. 2nd and 5th harmonic blocking) is still required for such 87T differential relay.

Keywords

Differential Protection, FACTS, Phase Angle Regulating Transformers

* zoran.gajic@se.abb.com

1. Introduction

Diverse differential protection schemes for Phase Angle Regulating Transformers (PAR) are presently used [3], [4]. These schemes tend to be dependent on the particular design details and maximum phase angle shift of the protected PAR. A special report has been written by IEEE-PSRC which describes possible protection solutions for typical PAR constructions [4]. It is indicated that the standard 87T transformer differential protection relays can not be used as overall differential protection due to variable phase angle shift across the PAR.

Thus, if a numerical 87T differential relay is directly applied for the overall differential protection of a PAR, and set to compensate for vector group Yy0, the false differential current will appear as soon as PAR phase angle shift is different from zero degrees. However, in this paper it will be shown that with help of numerical technology it is actually possible to apply the 87T transformer differential relay with a small modification as overall differential protection for PAR transformer in accordance with Figure 1.

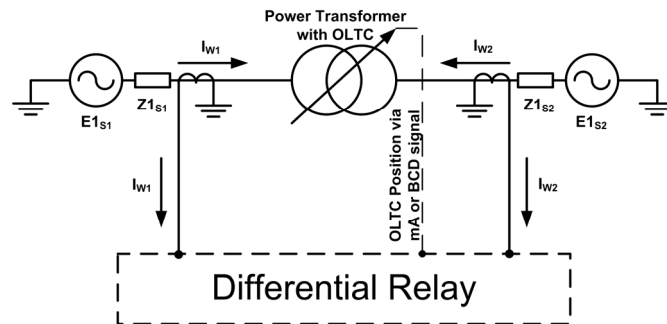

Figure 1 : Connections for overall PAR differential relay

2. Universal 87T Relay Compensation Principles

To provide overall differential protection for arbitrary PAR transformer it is necessary to provide the following three compensations in relay software:

- for current magnitude differences on the different sides of the protected PAR transformer;
- for arbitrary phase angle shift across PAR transformer;
- possibility to remove zero sequence current from any side of the PAR transformer.

Based on theory of symmetrical components applied to regulating transformers [1] it was shown in reference [3] that all three compensations can be achieved by using the following general equation for differential current calculations for any two-winding PAR transformer:

$$\begin{bmatrix} I_{d_L1} \\ I_{d_L2} \\ I_{d_L3} \end{bmatrix} = \sum_{i=1}^2 \frac{1}{I_{b_Wi}} \cdot MX(\Theta_{Wi}) \cdot \begin{bmatrix} I_{L1_Wi} \\ I_{L2_Wi} \\ I_{L3_Wi} \end{bmatrix} \quad (1.1)$$

where:

- I_{d_Lx} are phase-wise differential currents in per-unit system
- I_{b_Wi} is base current for the winding-i (It can have different values if the winding incorporates OLTC.)
- $MX(\Theta_{Wi})$ is a 3x3 matrix equal to either $M(\Theta_{Wi})$ on side(s) where only phase angle shift compensation is required or $M0(\Theta_{Wi})$ on side(s) where zero sequence current shall also be eliminated
- I_{Lx_Wi} are measured phase currents for winding-i

The formulas how to calculate base current and the two different types of 3x3 compensation matrixes, according to reference [3], are given below.

$$I_{Base_Wi} = \frac{S_{Base}}{\sqrt{3} \cdot U_{r_{Wi}}} \quad (1.2)$$

$$M(\Theta_{Wi}) = \frac{1}{3} \cdot \begin{bmatrix} 1 + 2 \cdot c \cos(\Theta_{Wi}) & 1 + 2 \cdot \cos(\Theta_{Wi} + 120^\circ) & 1 + 2 \cdot \cos(\Theta_{Wi} - 120^\circ) \\ 1 + 2 \cdot \cos(\Theta_{Wi} - 120^\circ) & 1 + 2 \cdot c \cos(\Theta_{Wi}) & 1 + 2 \cdot \cos(\Theta_{Wi} + 120^\circ) \\ 1 + 2 \cdot \cos(\Theta_{Wi} + 120^\circ) & 1 + 2 \cdot \cos(\Theta_{Wi} - 120^\circ) & 1 + 2 \cdot c \cos(\Theta_{Wi}) \end{bmatrix} \quad (1.3)$$

$$M0(\Theta_{Wi}) = \frac{2}{3} \cdot \begin{bmatrix} c \cos(\Theta_{Wi}) & \cos(\Theta_{Wi} + 120^\circ) & \cos(\Theta_{Wi} - 120^\circ) \\ \cos(\Theta_{Wi} - 120^\circ) & c \cos(\Theta_{Wi}) & \cos(\Theta_{Wi} + 120^\circ) \\ \cos(\Theta_{Wi} + 120^\circ) & \cos(\Theta_{Wi} - 120^\circ) & c \cos(\Theta_{Wi}) \end{bmatrix} \quad (1.4)$$

where:

- S_{Base} is the maximum rated apparent power of the protected transformer [2]
- $U_{r_{Wi}}$ is the winding-i rated phase-to-phase no-load voltage
- Θ_{Wi} is the angle associated with winding-i in order to provide phase angle shift compensation. The value for Θ_{Wi} is selected as the angle for which the winding-i positive sequence, no-load voltage component shall be rotated in order to overlay with the positive sequence, no-load voltage component from the reference winding. For the reference winding this angle Θ has the value of zero degrees

Note that it is possible to freely mix $M(\Theta_{Wi})$ and $M0(\Theta_{Wi})$ matrixes within one equation. For wining(s) where matrix transformation $M(\Theta_{Wi})$ is selected only the phase angle shift compensation will be performed while for winding(s) where matrix transformation $M0(\Theta_{Wi})$ is selected both the phase angle shift compensation and the zero sequence current reduction will be performed.

3. Application of 87T on a PAR Transformer of Asymmetrical Dual Core Design

In this section the recorded files from an installation of two identical PAR transformers positioned at one end of two parallel 380kV overhead lines (OHL) are used to present practical application and check performance of the universal 87T differential method. Every PAR is of asymmetric, dual-core design [5] with rating 1630MVA; 50Hz; 400kV; +18°. A relevant part of the PAR rating-plate is shown in Figure 2. The on-load tap-changer (OLTC) was on position 30 when this fault occurred. The first column in Figure 2 represents the available OLTC positions, in this case 33. From column three it is obvious that the base current for the PAR source side is constant for all positions and has a value of 2353A. Column five in Figure 2 gives the base current variation for the PAR load side. Finally the fourteenth column in Figure 2 shows how the no-load phase angle shift varies across the PAR transformer for different OLTC positions.

Note that the phase angle shift on the PAR rating plate is given as a positive value when the load side no-load voltage leads the source side no-load voltage [5] (i.e. advanced mode of operation). Therefore, if the phase shift from Figure 2 is associated with the load side (i.e. source side taken as reference side with zero degree phase shift) the angle values from the rating plate must be taken with the minus sign. Note also that this particular PAR has a five-limb core construction for the both internal transformers (i.e. serial and excitation transformer). Therefore the zero sequence current will be properly transferred across the

PAR and $M(\Theta)$ matrices can be used on both PAR sides (i.e. it is not required to remove zero sequence currents). From the data presented in Figure 2 the following equation is written for OLTC position 30 in accordance with the methodology of the universal 87T relay [4].

$$\begin{bmatrix} Id_{L1} \\ Id_{L2} \\ Id_{L3} \end{bmatrix} = \frac{1}{2353} \cdot M(0^\circ) \cdot \begin{bmatrix} I_{L1_S} \\ I_{L2_S} \\ I_{L3_S} \end{bmatrix} + \frac{1}{2257} \cdot M(-16.4^\circ) \cdot \begin{bmatrix} I_{L1_L} \\ I_{L2_L} \\ I_{L3_L} \end{bmatrix} \quad (1.5)$$

In a similar way this matrix equation can be written for any other OLTC position if appropriate values from Figure 2 are given for the base current and the phase angle shift on the load side of the PAR transformer.

The captured recording represents two simultaneous single phase to ground faults on two OHLs connected on the L-side of the two PARs. On OHL #1, connected in series with PAR #1, it was a phase L2 to ground fault while on OHL #2, connected in series with PAR #2, it was a phase L1 to ground fault. Actually two separate recordings, one per PAR, were captured during this fault by existing numerical differential relays having sampling rates of twelve samples per power system cycle. Recorded source and load side current waveforms were run in a MATLAB model of the universal 87T differential relay. In Figure 3a and Figure 3b the following recorded or calculated traces are presented:

- PAR S-side current waveforms in pu
- PAR L-side current waveforms in pu
- Instantaneous differential current waveforms calculated by using equation (1.5), in pu
- RMS values of differential currents calculated by using equation (1.5), in pu
- Phase angle difference between positive and negative sequence currents from the two PAR sides during the disturbance.

The two figures show that during this special external fault individual phase currents had values in the order of 10pu, while the differential RMS currents calculated by the universal 87T differential relay remain within 0,15pu (i.e. 15%) of the PAR rating for both transformers. This indicates that the universal 87T differential relays would remain completely stable during this special external fault. The measured phase angle shift between the sequence current components from the two PAR sides is $\pm 16^\circ$ and it corresponds well with actual the phase angle shift for this PAR at OLTC position 30 confirming the rules stated in [1]. Note that neither the fault inception nor the fault clearance has any practical influence on the phase angle shift of 16° between the positive sequence current components from the two sides of the protected PAR transformer.

4. Variable Frequency Transformer System

The variable frequency transformer (VFT) is a controllable, bi-directional transmission device that can transfer power between two asynchronous AC networks [7], [8]. Functionally, the VFT is similar to a back-to-back HVDC converter. The core technology of the VFT is a rotary transformer with three-phase windings on both rotor and stator. A motor and drive system are used to adjust the rotational position of the rotor relative to the stator, thereby controlling the magnitude and direction of the power flowing through the VFT. Essentially VFT is a continuously variable PAR transformer that can operate for any phase angle shift Ψ as shown in Figure 4. Note that the angle Ψ depends on the relative position between stator and rotor, while the rotor speed of rotation depends on the frequency difference between the two interconnected networks. Thus from the differential protection point of view the value of the angle Ψ will continuously change in time.

Terminal	Source		Load		Series winding		Booster winding		Exciter winding		Regulation winding		Phase angle at no load advanced
	S8, S12, S4		L8, L12, L4		S8, S12, S4 L8, L12, L4		A25,A26,B25,B26 C25,C26		S8, S12, S4 E0		A4, B4, C4 FD		
Pos.	Voltage V	Current A	Voltage V	Current A	Voltage V	Current A	Voltage V	Current A	Voltage V	Current A	Voltage V	Current A	
33	400000	2353	420509	2238	74895	2238	121245	1382	400000	725.8	121245	2394	18.0°
32	400000	2353	419276	2245	72555	2245	117456	1386	400000	705.2	117456	2401	17.4°
31	400000	2353	418079	2251	70214	2251	113667	1390	400000	684.4	113667	2408	16.9°
30	400000	2353	416918	2257	67874	2257	109878	1394	400000	663.4	109878	2415	16.4°
29	400000	2353	415793	2263	65533	2263	106089	1398	400000	642.3	106089	2422	15.8°
28	400000	2353	414705	2269	63193	2269	102300	1402	400000	620.9	102300	2428	15.3°
27	400000	2353	413653	2275	60852	2275	98512	1405	400000	599.5	98512	2434	14.8°
26	400000	2353	412639	2281	58512	2281	94723	1409	400000	577.8	94723	2440	14.2°
25	400000	2353	411662	2286	56171	2286	90934	1412	400000	556.0	90934	2446	13.7°
24	400000	2353	410723	2291	53831	2291	87145	1415	400000	534.1	87145	2451	13.1°
23	400000	2353	409822	2296	51490	2296	83356	1418	400000	512.0	83356	2457	12.6°
22	400000	2353	408959	2301	49150	2301	79567	1421	400000	489.7	79567	2462	12.0°
21	400000	2353	408134	2306	46809	2306	75778	1424	400000	467.4	75778	2467	11.5°
20	400000	2353	407348	2310	44469	2310	71989	1427	400000	444.9	71989	2472	10.9°
19	400000	2353	406601	2315	42128	2315	68200	1430	400000	422.2	68200	2476	10.3°
18	400000	2353	405893	2319	39788	2319	64411	1432	400000	399.5	64411	2481	9.8°
17C	400000	2353	405225	2322	37448	2322	60623	1435	400000	376.6	60623	2485	9.2°
17B	400000	2353	405225	2322	37448	2322	60623	1435	400000	376.6	60623	2485	9.2°
17A	400000	2353	405225	2322	37448	2322	60623	1435	400000	376.6	60623	2485	9.2°
16	400000	2353	404595	2326	35107	2326	56834	1437	400000	353.6	56834	2489	8.6°
15	400000	2353	404006	2329	32767	2329	53045	1439	400000	330.5	53045	2492	8.1°
14	400000	2353	403457	2333	30426	2333	49256	1441	400000	307.3	49256	2496	7.5°
13	400000	2353	402947	2335	28086	2335	45467	1443	400000	284.0	45467	2499	6.9°
12	400000	2353	402478	2338	25745	2338	41678	1444	400000	260.7	41678	2502	6.4°
11	400000	2353	402049	2341	23405	2341	37889	1446	400000	237.2	37889	2504	5.8°
10	400000	2353	401660	2343	21064	2343	34100	1447	400000	213.7	34100	2507	5.2°
9	400000	2353	401313	2345	18724	2345	30311	1449	400000	190.1	30311	2509	4.6°
8	400000	2353	401005	2347	16383	2347	26522	1450	400000	166.5	26522	2511	4.1°
7	400000	2353	400739	2348	14043	2348	22733	1451	400000	142.8	22733	2513	3.5°
6	400000	2353	400513	2350	11702	2350	18945	1451	400000	119.1	18945	2514	2.9°
5	400000	2353	400329	2351	9362	2351	15156	1452	400000	95.3	15156	2515	2.3°
4	400000	2353	400185	2352	7021	2352	11367	1453	400000	71.5	11367	2516	1.7°
3	400000	2353	400082	2352	4681	2352	7578	1453	400000	47.7	7578	2517	1.2°
2	400000	2353	400021	2353	2340	2353	3789	1453	400000	23.8	3789	2517	0.6°
1	400000	2353	400000	2353	0	2353	0	1453	400000	0	0	2517	0°

Auxiliary winding	Voltage 15000 V
-------------------	--------------------

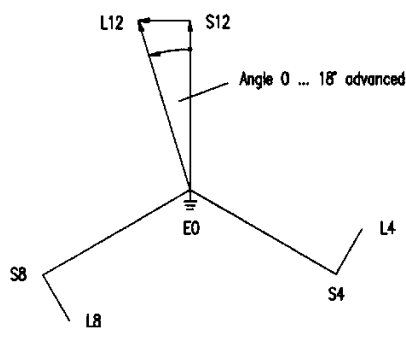
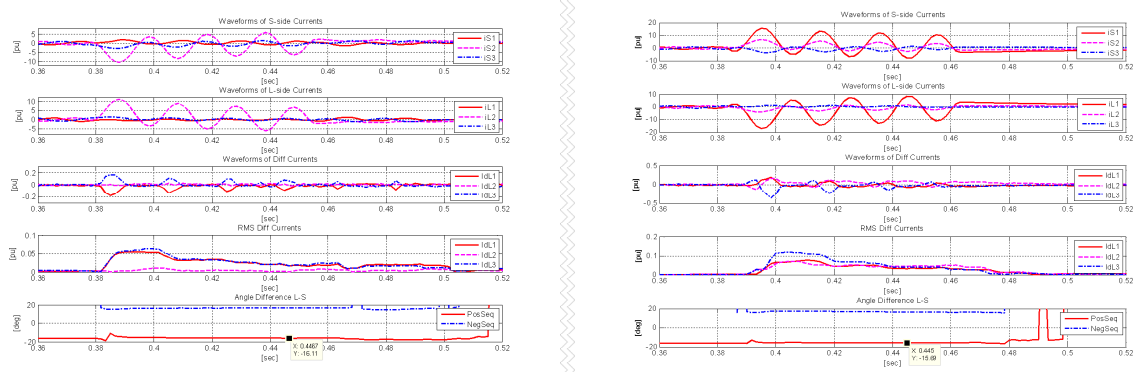

Figure 2 : Rating plate of the PAR with asymmetrical type, dual core design



a) First PAR Transformer

b) Second PAR Transformer

Figure 3 : Behaviour of the overall 87T differential relay for captured recording of external fault

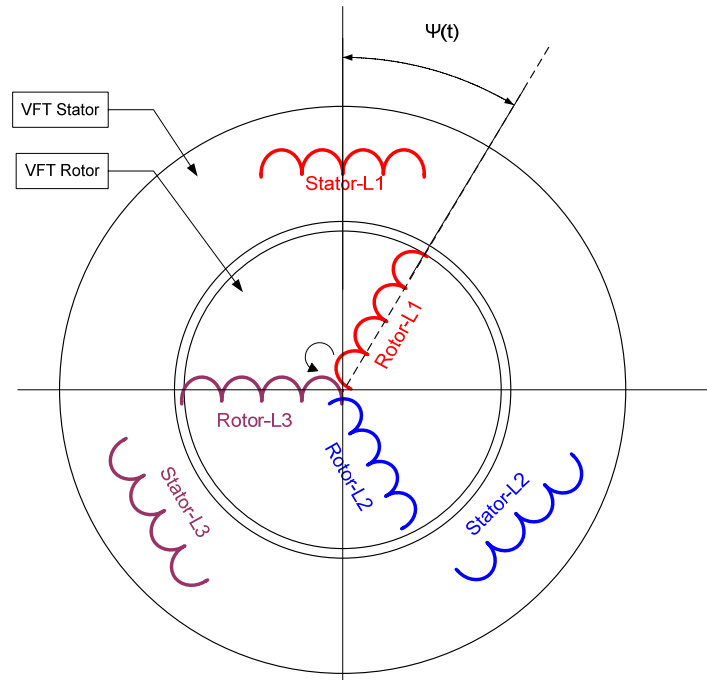

Figure 4 : VFT principle drawing

Now equation (1.1) can be written in the following way for VFT:

$$\begin{bmatrix} Id_L1 \\ Id_L2 \\ Id_L3 \end{bmatrix} = \frac{1}{I_{Base_Stator}} \cdot M(0^\circ) \cdot \begin{bmatrix} I_{L1_S} \\ I_{L2_S} \\ I_{L3_S} \end{bmatrix} + \frac{1}{I_{Base_Rotor}} \cdot M(\Psi(t)) \cdot \begin{bmatrix} I_{L1_R} \\ I_{L2_R} \\ I_{L3_R} \end{bmatrix} \quad (1.6)$$

$$M(\Psi(t)) = \begin{bmatrix} x(t) & y(t) & z(t) \\ z(t) & x(t) & y(t) \\ y(t) & z(t) & x(t) \end{bmatrix} \quad (1.7)$$

Where:

- I_{Lx_S} are the measured phase currents for the stator winding
- I_{Lx_R} are the measured phase currents for the rotor winding
- x , y and z are the individual elements of the rotor $M(\Psi(t))$ matrix

Thus if the value of the angle Ψ is known to the differential relay at any time instant, for example via a communication link or via a mA signal, the overall differential currents can be calculated by using equation (1.6) in accordance with the setup shown in Figure 1. One example will be shown here. In Figure 5 the following traces are shown:

- a) Stator three phase current waveforms with a frequency of 50Hz
- b) Rotor three phase current waveforms with a frequency of 51Hz
- c) Values of the three elements x , y and z , as shown in equation (1.7), in the rotor $M(\Psi(t))$ matrix used for the phase angle shift compensation
- d) Three-phase differential current waveforms as calculated by the differential protection using equation (1.6)

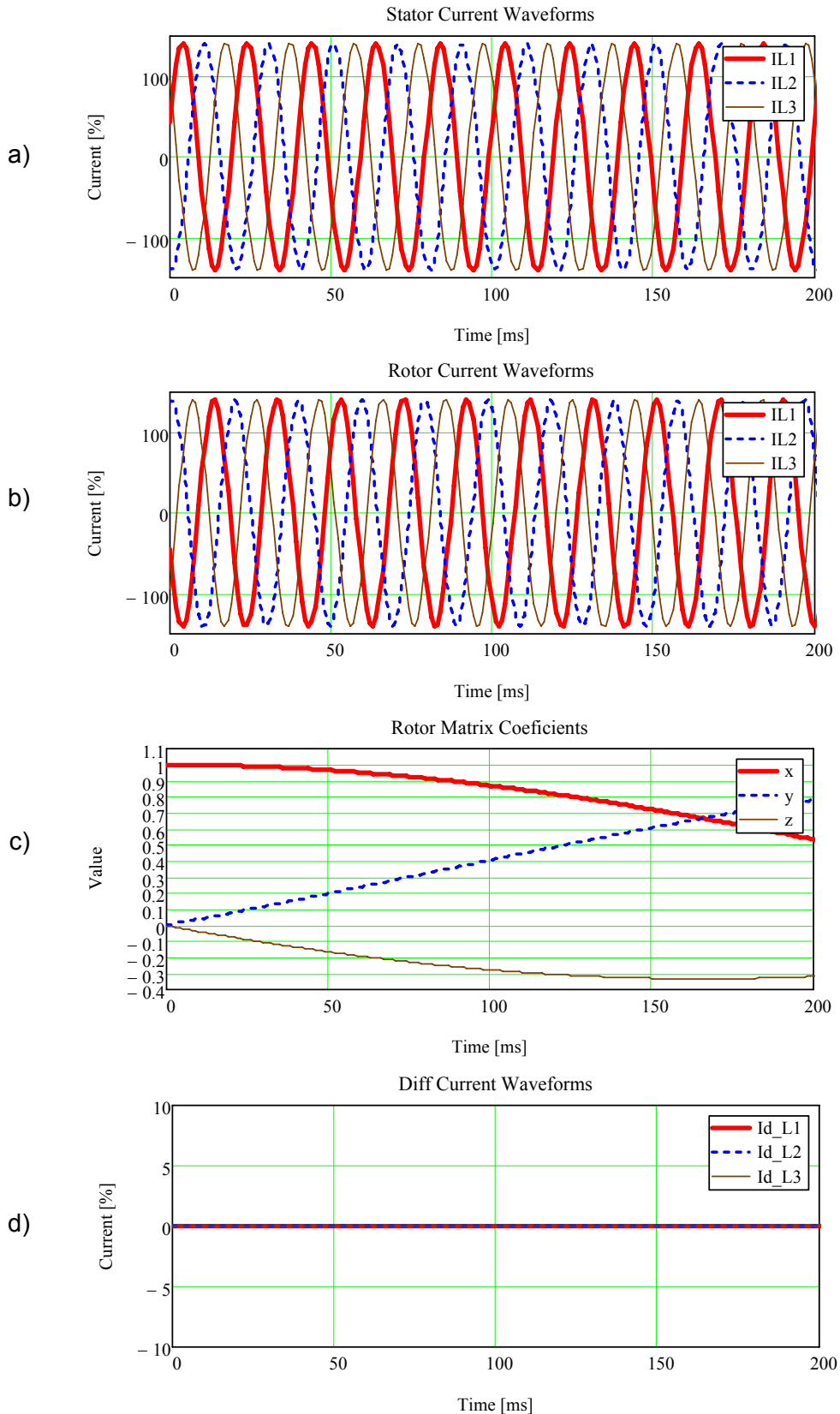

Figure 5 : Example of overall differential protection for VFT transformer

Note that calculated differential current waveforms, by the differential protection using equation (1.6), are always equal to zero irrespective of different frequencies of the stator and rotor currents. Thus the overall VFT differential protection is fully balanced for this particular case.

5. Conclusion

The feasibility of advanced on-line phase angle shift compensation within a universal 87T differential protection for PAR transformer applications has been demonstrated. Such 87T relay provides simple but effective differential protection for all types of PAR transformers. The relay is very similar to already well-established numerical 87T differential protection relays used for standard power transformers. The only difference is that elements of $M(\Theta)$ or $M0(\Theta)$ matrices, used to provide the phase angle shift compensation and the optional zero sequence current reduction, are not pre-programmed and fixed within the differential relay, but are instead calculated on-line. The calculation is based on the information about actual phase angle shift (e.g. based on actual OLTC position). Exact formulas how to calculate these matrices are given in the paper.

Such universal 87T differential relay will also eliminate any need for buried current transformers within the protected power transformer tank as usually required by presently used PAR differential protection schemes [4], [5], [6].

It seems also possible to use the same approach for overall differential protection of Variable Frequency Transformers.

Bibliography

- [1] Electrical Transmission and Distribution Reference Book, 4th edition, Westinghouse Electric Corporation, East Pittsburgh, PA 1950.
- [2] BBC Document CH-ES 53-10 E, "Instruction for Planning Differential Protection Schemes", BBC, Baden, Switzerland, January 1980.
- [3] Z. Gajić, "Differential Protection for Arbitrary Three-Phase Power Transformer", PhD Thesis, Lund University, Sweden, Feb 2008, ISBN: 978-91-88934-47-5; <http://www.iea.lth.se/publications/pubphd.html>
- [4] IEEE Special Publication, "Protection of Phase Angle Regulating Transformers (PAR)," A report to the Substation Subcommittee of the IEEE Power System Relaying Committee prepared by Working Group K1, Oct. 1999.
- [5] Guide for the application, specification, and testing of phase-shifting transformers, International Standard IEC 62032/IEEE C57.135, First edition 2005-03.
- [6] Z. Gajić, S. Holst, D. Bonmann, D.A.W. Baars, "Influence of Stray Flux on Protection Systems," IEE Conference on Developments in Power System Protection, Glasgow, UK, March 2008.
- [7] J.-M. Gagnon et al, "A 100 MW Variable Frequency Transformer (VFT) on the Hydro-Québec Network", CIGRE Session 2006, Paris-France.
- [8] R.J. Piwko, E.V. Larsen, "Variable Frequency Transformer – FACTS Technology for Asynchronous Power Transfer", IEEE PES T&D Conference and Exposition, New Orleans, 2005.