

---

# **Technical reference manual**

## **RXHL 411 and RAHL 411**

### **Compact current relay and protection assemblies**

#### **About this manual**

DocID: 1MRK 509 051-UEN

Issue date: January 2000

Status: New

Version: Initial version

© ABB Automation Products AB 2000  
Substation Automation Division

---

## **COPYRIGHT**

WE RESERVE ALL RIGHTS TO THIS DOCUMENT, EVEN IN THE EVENT THAT A PATENT IS ISSUED AND A DIFFERENT COMMERCIAL PROPRIETARY RIGHT IS REGISTERED. IMPROPER USE, IN PARTICULAR REPRODUCTION AND DISSEMINATION TO THIRD PARTIES, IS NOT PERMITTED.

THIS DOCUMENT HAS BEEN CAREFULLY CHECKED. IF THE USER NEVERTHELESS DETECTS ANY ERRORS, HE IS ASKED TO NOTIFY US AS SOON AS POSSIBLE.

THE DATA CONTAINED IN THIS MANUAL IS INTENDED SOLELY FOR THE PRODUCT DESCRIPTION AND IS NOT TO BE DEEMED TO BE A STATEMENT OF GUARANTEED PROPERTIES. IN THE INTERESTS OF OUR CUSTOMERS, WE CONSTANTLY SEEK TO ENSURE THAT OUR PRODUCTS ARE DEVELOPED TO THE LATEST TECHNOLOGICAL STANDARDS. AS A RESULT, IT IS POSSIBLE THAT THERE MAY BE SOME DIFFERENCES BETWEEN THE HW/SW PRODUCT AND THIS INFORMATION PRODUCT.

### **Manufacturer:**

ABB Automation Products AB  
Substation Automation Division  
Dept. TC  
721 59 Västerås  
Tel: +46 (0) 21 34 20 00  
Fax: +46 (0) 21 14 69 18  
Internet: <http://www.abb.com>

<b>Chapter</b>	<b>Page</b>
<b>Chapter 1 Introduction .....</b>	<b>1</b>
Introduction to the technical reference manual .....	2
About this manual .....	2
Intended audience .....	2
Related documents .....	3
Revisions .....	3
<b>Chapter 2 Overview .....</b>	<b>5</b>
Features .....	6
General .....	8
Compact current relay RXHL 411 .....	8
Functions .....	9
Overcurrent protection .....	9
Thermal overload protection .....	10
Earth-fault protection .....	12
Breaker failure protection .....	13
Automatic reclosing function (Option) .....	14
Intentional overreach trip function (Option) .....	14
<b>Chapter 3 Application .....</b>	<b>17</b>
Protection system requirements .....	18
Overcurrent protection .....	19
Selection of type of short-circuit line protection in Medium Voltage (MV) networks .....	19
Selection of type of earth-fault line protection in Medium Voltage (MV) networks .....	24
Protection for cross-country faults .....	26
Blocking and enabling functions .....	26
Intentional overreach .....	28
Time characteristics .....	29
Selectivity .....	32
Setting of phase overcurrent short-circuit protection in radial networks .....	35
Back-up protection .....	39
Three-phase versus two-phase overcurrent protection .....	41
Example of a selectivity plan .....	42
Relay 4 .....	44
Relay 3 .....	45
Relay 2 .....	45
Relay 1 .....	46

---

Thermal overload protection .....	48
Settings .....	51
Determining the time constant .....	52
Earth-fault protection.....	54
Earth-fault protection in ungrounded or high-impedance grounded system.....	54
Earth-fault protection in low-impedance grounded system .....	58
Earth-fault protection in solidly grounded system .....	58
Connection of earth-fault relay.....	61
Breaker failure protection.....	63
Automatic reclosing function .....	64
Binary inputs .....	66

## **Chapter 4 Requirements ..... 67**

Demands on the current transformer .....	68
Overcurrent protection .....	68
Accuracy limit factor (ALF) - Calculation example .....	70
Earth-fault protection .....	71

## **Chapter 5 Functional description..... 75**

Compact current relay RXHL 411 .....	76
Theory of operation.....	76
Setting parameters .....	77
Overcurrent protection .....	79
Theory of operation.....	79
Binary input and output signals.....	80
Setting parameters .....	81
Thermal overload protection .....	82
Theory of operation.....	82
Input and output signals.....	83
Setting parameters .....	83
Earth-fault protection.....	84
Theory of operation.....	84
Input and output signals.....	85
Setting parameters .....	86
Breaker failure protection.....	87
Theory of operation.....	87
Input and output signals.....	88
Setting parameters .....	89
Intentional overreach trip function.....	90
Theory of operation.....	90
Input and output signals.....	90
Setting parameters .....	91
Automatic reclosing function .....	92
Theory of operation.....	92

---

Input and output signals.....	95
Setting parameters .....	96
Indications.....	97
Indications menu.....	97
Input and output signals.....	98
Active setting group .....	99
Theory of operation.....	99
Input and output signals.....	99
Setting parameters .....	99
Self-supervision .....	100
Theory of operation.....	100

## **Chapter 6 Design description..... 101**

Protection assembly .....	102
Compact current protection assembly RAHL.....	102
Test switch RTXP 18 .....	103
DC/DC-converter RXTUG 22H .....	104
Measuring relay .....	104
Tripping relay RXME 18.....	110
Equipment frames and relay cases .....	111
19" equipment frame.....	111
RHGS cases for 19" cubicle mounting or surface mounting.....	111
RHGX cases for flush- or semi-flush panel mounting.....	111
Protection assemblies.....	112
Mounting alternatives.....	113

## **Chapter 7 Technical data ..... 115**

Compact current relay RXHL 411 .....	116
Functions .....	122

## **Chapter 8 Ordering..... 129**

RAHL protections.....	130
Basic data to specify .....	130
Options .....	130
Accessories .....	131
RXHL relays.....	132
Functions included in basic version .....	132
Basic data to specify .....	132
Options .....	132
Accessories .....	133

---

# Chapter 1 Introduction

## **About this chapter**

This chapter introduces the user to the content in the manual. The intended use of the manual and the intended audience is described. The introduction chapter also contains references to other documents.

# 1 Introduction to the technical reference manual

## 1.1 About this manual

The technical reference manual describes how the relay can be applied and used for different purposes. The manual is intended to be used when calculating how the relay could be configured to suit different networks and systems. The technical reference manual is also intended to be used for reference purposes when knowledge in how the relay is designed and the theories of operation is needed. The technical reference manual does not contain any instructions, only technical descriptions about the relay and the protection assemblies.

The technical reference manual contains the following chapters:

- The *overview* chapter gives a brief overview over the application and design of the protection.
- The *requirements* chapter contains descriptions concerning the different requirements that have to be fulfilled in order to achieve reliable operation of the protection.
- The *functional description* chapter contains description about the theories of operation for the protection.
- The *design description* chapter contains description about the different parts that constitutes the protection assembly.
- The *technical data* chapter contains technical data presented in tables.
- The *ordering* chapter contains ordering tables which could be used when ordering.

## 1.2 Intended audience

### 1.2.1 General

The intended audience is the system engineer responsible for calculating how the relay should be set and configured.

### 1.2.2 Requirements

The intended audience is supposed to have good knowledge in protection systems for transmission and distribution electrical systems in order to understand the content in this manual.

### 1.3

#### Related documents

<b>Document related to COMBIFLEX<sup>®</sup> assemblies</b>	<b>Identity number</b>
Buyer's guide, Connection and installation components in COMBIFLEX <sup>®</sup>	1MRK 513 003-BEN
Buyer's guide, Relay accessories and components	1MRK 513 004-BEN
Buyer's guide, Test system COMBITEST	1MRK 512 001-BEN
Buyer's guide, DC-DC converter	1MRK 513 001-BEN
Buyer's guide, Auxiliary relays	1MRK 508 015-BEN

<b>Documents related to RXHL 411 and RAHL 411</b>	<b>Identity number</b>
Technical overview brochure	1MRK 509 049-BEN
Connection and setting guide (only RXHL 411)	1MRK 509 049-WEN
Operator's manual	1MRK 509 050-UEN
Technical reference manual	1MRK 509 051-UEN
Installation and commissioning manual	1MRK 509 052-UEN

### 1.4

#### Revisions

<b>Revision</b>	<b>Description</b>
-	Initial version



# Chapter 2 Overview

## **About this chapter**

This chapter introduces the user to the measuring relay. The features are presented and the application and the design for each protection function is given as a summary. By reading this chapter the user will gain an overview over the functionality of the relay.

## 1

## Features

### Three phase compact current relay for:

- **Phase overcurrent protection, three stages**
- **Thermal overload protection, one stage**
- **Earth-fault overcurrent protection, three stages**
- **Breaker failure protection**
- **Automatic reclosing (option)**
- Phase and earth fault overcurrent protection functions with
  - Three stages, the first stage has selectable time delay; definite or inverse. The second and the third stage have definite time delay
  - Logic for detection and clearance of intermittent faults
- Thermal overload protection
  - Stage with alarm and trip level
  - Thermal time constant settable within a wide range
- Breaker-failure protection
  - Start of the breaker failure protection both from internal and external protection functions
  - Re-trip initiated from external start
  - Back-up trip if settable current levels are exceeded after a settable delay
- General characteristics for the relay
  - There are two groups of parameters settable and readable through the HMI
  - The dialog with the relay can be made in English or Swedish
  - There are two binary inputs for blocking or enabling of selected functions. The binary inputs can also be used for change of setting groups
  - There are five binary output relays, which can be independently configured for the different protection functions
  - Service values (primary/secondary) and disturbance information can be presented through the HMI

- 
- Start, trip can be presented through the HMI
  - The relay has self-supervision with output error signal
  - Testing of the output relays and operation of the binary inputs can be performed through the HMI
  - Options
    - Three phase autoreclosing with up to four shots. The autoreclosing can co-operate with an intentional overreach function in order to increase probability of successful reclosing, protect fuses and/or to reduce thermal stress
    - An additional binary I/O module can be added (4 additional inputs and 4 additional outputs)

## **2 General**

### **2.1 Compact current relay RXHL 411**

The compact current relay RXHL 411 has a wide application range from main to back-up protection for feeders and lines, transformers, capacitor banks, electric boilers as well as for generators and motors.

The relay can also be used as a stand alone breaker-failure protection.

---

## 3 Functions

### 3.1 Overcurrent protection

#### 3.1.1 Application

In radially fed power networks the phase overcurrent function can be used as main or back-up short circuit protection for lines and transformers. The time current characteristic (definite time or any of the inverse time characteristics) should be chosen according to common practice in the network. Normally the same time current characteristic is used for all phase overcurrent relays in the network. This includes phase overcurrent protection for lines, transformers and other equipment. The measuring relay offers great flexibility in the choice of time characteristic.

There is a possibility to use phase overcurrent protection in meshed systems as short circuit protection for lines. It must however be realised that the setting of a short circuit protection system in meshed networks, can be very complicated and a large number of fault current calculations are required. There are situations where there is no possibility to achieve selectivity with a protection system based on phase overcurrent relays in a meshed system. In combination with impedance relays or line differential protections, phase overcurrent relays can serve as back-up short circuit protection for parts of the lines.

For shunt capacitors, shunt reactors, motors and other similar equipment phase overcurrent protection can serve as main or back-up short circuit protection. Also for these applications the time characteristics should be chosen so that co-ordination with other overcurrent protection in the power system can be made.

As the short circuit current level will change depending on the switching state in the power system, there is a great benefit to be able to change parameter-setting groups when the switching state in the system is changed. The measuring relay will enable this.

The blocking option can be used to decrease fault time for some fault points (for example busbars) in radially fed networks.

#### 3.1.2 Design

The overcurrent protection has a low set stage with inverse or definite time delayed function. The inverse time characteristics are provided with minimum operate time for improved selectivity in certain applications. The low set stage also has a reset time logic for detection of intermittent faults. If the protection starts and the fault current drops the reset of the function will be made gradually so that the integrated fault current time area will be remembered for some time. In case of an intermittent fault every re-strike of the fault will increase the integrated current-time area so that the fault can be tripped.

---

The overcurrent protection has two high set stages with definite time delayed function. The overcurrent protection is designed for low transient overreach which allows extended reach and smaller setting margins.

The following characteristics are selectable for the low set stage (diagrams are shown in the chapter “Design description”):

1. Definite time delayed
2. Inverse time delayed:
  - Normal inverse (NI)
  - Very inverse (VI)
  - Extremely inverse (EI)
  - Long time inverse (LI)
  - RI inverse (RI)

NI, VI, EI and LI according to IEC 60255-3.

RI-curve according to old electromechanical relays manufactured by ASEA.

## 3.2 Thermal overload protection

### 3.2.1 Application

When load currents exceed the permitted continuous current there is a risk that the conductor or the insulation will be subject to permanent damage due to the overheating. The thermal overload protection effectively prevents such damage and at the same time, allows full utilization of the protected object.

The thermal overload protection is mainly applicable to the protection of motors, transformers and cables as the ambient factors (ambient temperature, cooling, etc) are relatively constant. The temperature of the conductor is mainly dependent on the current.

The overload protection can also be used for overhead lines. In these cases, it must however be realised that the temperature estimation of the conductor can have relatively large errors due to the ambient conditions, such as wind etc.

### 3.2.2 Design

The thermal overload protection has an alarm and a trip function. The thermal formula is according to IEC 60255-8. The thermal function is provided with a wide parameter setting range for improved selectivity.

The thermal time constant,  $\tau$ , is defined as the time required by the protected object to reach  $\theta = 63\%$  of the steady-state temperature,  $\theta_s$ , when the object in question is supplied with a constant current.

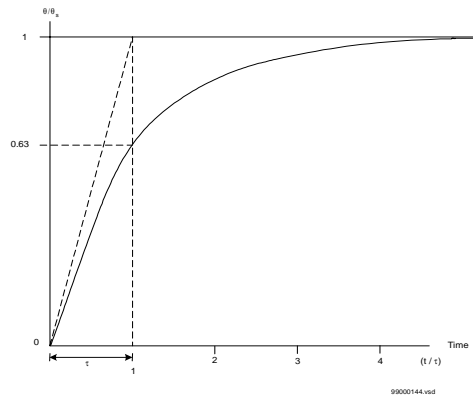

Figure 1: Definition of thermal time constant

Thermal operating time formula:

$$t = \tau \cdot \ln \frac{I^2 - I_p^2}{I^2 - I_b^2}$$

Where:

$t$  = operate time

$\tau$  = set time constant

$I_p$  = load current before the overload occurs

$I$  = load current

$I_b$  = set operate current

## 3.3 Earth-fault protection

### 3.3.1 Application

The earth-fault protection is non-directional and based on a measurement of the residual current. It is mainly used in solidly and low impedance grounded networks. In high impedance grounded networks, the size of the network and national standards are the factors determining whether the protection can be used. The high set stages are used in the similar way as they are in the phase overcurrent protection, but only in solidly and low impedance grounded networks.

In solidly grounded networks the earth-fault currents can be of the same order of magnitude as the short-circuit currents.

Earth-faults with high fault resistance can be detected by measuring the residual current. This type of protection provides maximum sensitivity to high resistive earth-faults. It is often required to clear the earth-faults with residual currents of magnitudes which are as low as 50-100A.

In high-impedance grounded networks a sensitive non-directional earth-fault overcurrent function can be used as a protection for cross-country faults. This is due to the fact that there is a risk that cross-country faults will not activate directional earth-fault overcurrent relays.

In some systems a medium impedance resistive system grounding is used. The neutral point resistor will give an earth-fault current, larger than the capacitive earth-fault current of the lines and cables in the system. If the system is operated radially the non-directional earth-fault overcurrent protection can be used as earth-fault line protection.

In many applications a directional function of the residual overcurrent protection is desirable. In such cases the measuring relay can be used in combination with the directional relay RXPDK 23H, that will provide enable criteria in case of earth-faults in the forward direction.

Both inverse time characteristics protection as well as three step definite time characteristics are used. If inverse time characteristics are used with equal currents and time settings for all residual current protections in the system. Selectivity is usually achieved as long as there are more than two bays carrying fault current to each substation.

It is also possible to use the protection as a multi-stage earth-fault current line protection where the first stage has instantaneous function and covers most of the protected line. The second stage has a short delay (about 0.4 s) and covers the rest of the line. The third stage has a longer delay and will give relatively rapid and selective fault clearance of high resistive phase to earth-faults.

### 3.3.2

#### Design

The earth-fault protection has a low set stage with inverse or definite time delayed function. The inverse time characteristics are provided with minimum operate time for improved selectivity in certain applications. The low set stage also has a reset time logic for detection of intermittent faults. If the protection starts and the fault current drops the reset of the function will be made gradually so that the integrated fault current time area will be remembered for some time. In case of an intermittent fault every re-strike of the fault will increase the integrated current-time area so that the fault can be tripped. The earth-fault protection has two high set stages with definite time delayed function. The earth-fault protection is designed for low transient-overreach which allows extended reach and smaller setting margins.

The following characteristics are selectable for the low set stage (diagrams are shown in the chapter “Design description”):

1. Definite time delayed
2. Inverse time delayed:
  - Normal inverse (NI)
  - Very inverse (VI)
  - Extremely inverse (EI)
  - Long time inverse (LI)
  - RI inverse (RI)
  - Logarithmic inverse (LOG)

NI, VI, EI and LI according to IEC 60255-3.

RI-curve according to old electromechanical relays manufactured by ASEA.

LOG-curve according to RXIDG relay manufactured by ABB.

## 3.4

### Breaker failure protection

#### 3.4.1

##### Application

Breaker-failure protection is required to give a rapid back-up protection when the primary circuit-breaker does not break properly at e.g. a short-circuit in the network. In such a case all adjacent breakers are tripped by the breaker-failure protection. A simple and reliable way to secure the isolation of a fault is to check the appearance of fault current after a time. The time should be long enough to enable the circuit-breaker to operate.

**3.4.2****Design**

The breaker failure function can be activated from internal protection functions as well as from external protections via binary input. In many power systems the relay therefore is very suitable as a back-up protection for HV-lines with the integrated breaker failure protection as one of the most important back-up protection functions. A separate breaker failure protection relay is not needed in this case.

The operate values of the two current measuring elements, phase currents and neutral current are settable within a wide setting range. The measurement is stabilised against the DC-transient that can cause unwanted operation with saturated current transformers. Time measurement is the same for both measuring elements. The timer which operates trip logic for adjacent circuit-breakers.

**3.5****Automatic reclosing function (Option)****3.5.1****Application**

Automatic reclosing is a well-established method to restore the service of a power line after a transient fault. The majority of line faults are flashover arcs, which are transient by nature. When the power line is switched off by operation of the protection and line circuit-breakers, the arc de-ionizes and the contact recovers voltage withstand at a somewhat variable rate. So a certain line dead time is needed. But then line service can resume by the automatic reclosing of the line circuit-breakers. Select the length of the dead time to enable good probability of fault arc de-ionization and successful reclosing.

**3.5.2****Design**

The three-phase automatic reclosing function is built up by logical elements. The automatic reclosing function co-operates with the other functions in the protection, the trip function and the circuit-breakers. The automatic reclosing function can be selected to give either a high-speed automatic reclosing or a delayed automatic reclosing. Up to four reclosing shots can be selected. Via the binary input the automatic reclosing function can be blocked.

**3.6****Intentional overreach trip function (Option)****3.6.1****Application**

*Note: This function is not separately available. It is an addition to the automatic reclosing function.*

The probability of a successful high-speed automatic reclosing is significantly increased if the fault time is short. Therefore there might be a need for an intentional overreach, that is high speed trip even for faults outside the normal high set zone. In this way the interruption time can be reduced, on the other hand more customers will be interrupted, for non-selective trips. This arrangement has to be compared with selective trips by the time delayed stage, followed by a reclosing of a permanent fault and another time delayed trip.

### 3.6.2

#### **Design**

The intentional overreach function is built up on logical elements. The intentional overreach function co-operates with the start functions in the overcurrent protection and the automatic reclosing function. Time delay is used for fuse selectivity.



# Chapter 3 Application

## **About this chapter**

This chapter describes the application possibilities for the various protection functions available in the relay. The main purpose of each function is given and the different application variants. By reading this chapter the user will gain knowledge in how the relay can be used for different applications.

---

# 1 Protection system requirements

Protection systems have to fulfil different utility requirements. Often they also have to fulfil requirements specified in national safety regulations. In general the requirements can be summarized as follows:

- The protection system shall have a high degree of dependability. This means that the risk of missing fault clearance shall be low. Back-up protection is necessary to achieve this.
- The protection system shall have a high degree of security. This means that the risk of unwanted relay function shall be low.
- The fault clearing time shall be minimized in order to limit the damages to equipment, to assure angle stability and to minimize the risk for people from getting injuries.
- The protection system shall have sufficient sensitivity so that high resistive faults can be detected and cleared.
- The fault clearing shall be selective to minimize the outage and make it possible to continue the operation of the healthy parts of the power system.

## 2 Overcurrent protection

Two- or three-phase time-overcurrent relays can be used as phase to phase short-circuit protection in radial high impedance grounded networks for over-head lines, cable lines and transformers. Three-phase time-overcurrent relays can also be used as phase to phase and phase to ground short-circuit protection in solidly grounded radial networks for over-head lines, cable lines and transformers.

### 2.1 Selection of type of short-circuit line protection in Medium Voltage (MV) networks

It is difficult to give some very simple rules for the selection of line protection, in a MV system. However there are some hints given below.

The alternatives, considered here, for line short-circuit protection are the following:

#### Phase overcurrent protection

- Instantaneous function
- Definite time characteristics
- Current dependent time delay (inverse time characteristics)
- Any combination of instantaneous, definite time and inverse time function
- Directional/non-directional function

#### Current differential protection

- Phase segregated
- Non phase segregated (with auxiliary summation current transformers)

#### Distance protection

- Phase to phase loop measurement
- Phase to earth loop measurement

We study some examples of MV voltage power systems below.

#### 2.1.1 Radial solidly grounded MV system with single phase lines

For the single phase lines a short-circuit is actually a phase to earth-fault. We can therefore not distinguish between phase to phase and phase to earth-faults.

---

In most cases it is sufficient to use simple non-directional phase overcurrent relays. Here RAHL is applicable. The time current characteristic should be selected according to common practice in the network. Normally the same time current characteristic is used for all phase overcurrent relays in the network. This includes phase overcurrent protection for lines, transformers and other equipment. If the network has a solidly grounded transformer in the feeding point of the network only, the overcurrent relay can serve as a protection for single phase to earth-faults too. There can however be difficult to reach sufficient sensitivity for detection and clearance of high resistive earth-faults with this solution. This is due to the fact that it is difficult to distinguish between earth-fault current and normal load current.

In some applications there are short lines, with other objects connected in series (other lines, transformers or other power system objects). This is normally the case in distribution networks for urban areas. The use of overcurrent relays as short-circuit protection in these cases can result in long functional time delays to assure selectivity. A better alternative in such cases is often to use current differential protection as line short-circuit protection. The current differential protection can serve as protection for single phase to earth-faults as well.

In some cases fuses can be used as short-circuit protection of radial lines. However, in these cases the extremely inverse time characteristic in the relay can be used to achieve discrimination with fuses in the same network.

### 2.1.2

#### **Radial solidly grounded MV system with three phase lines only**

In most cases it is sufficient to use simple non-directional phase overcurrent relays. Here RAHL is applicable. The time current characteristic should be selected according to common practice in the network. Normally the same time current characteristic is used for all phase overcurrent relays in the network. This includes phase overcurrent protection for lines, transformers and other equipment. If the network has a solidly grounded transformer in the feeding point of the network only, the overcurrent relay can serve as a protection for single phase to earth-faults too. There can however be difficult to reach sufficient sensitivity for detection and clearance of high resistive earth-faults with this solution.

In some applications there are short lines, with other objects connected in series (other lines, transformers or other power system objects). This is normally the case in distribution networks for urban areas. The use of overcurrent relays as short-circuit protection in these cases can result in long functional time delays to assure selectivity. A better alternative in such cases is often to use current differential protection as line short-circuit protection. The current differential protection can serve as protection for single phase to earth-faults as well.

**2.1.3****Meshed solidly grounded MV system with three phase lines only**

There is a possibility to use overcurrent protection in meshed systems as short-circuit protection. It must however be realized that the setting of a short-circuit protection system in meshed networks, can be very complicated and a large number of fault current calculations are needed. When of the computer software for protection coordination, available at the market today, is of great help in these situations. Still, there might be situations where there is no possibility to have selectivity with a protection system based on overcurrent relays, in a meshed system.

The normal selection for short-circuit protection in meshed networks would be to use a protection system based on distance protection. The distance protection should have both phase-phase measurement loops as well as phase to earth measurement loops. The number of zones to be used is dependent on the way back-up protection shall be arranged. If local back-up is used two or three zones are normally sufficient. If remote back-up protection shall be used, for example for back-up protection of transformers, three or even more zones are required.

In some applications there are short lines, with other objects connected in series (other lines, transformers or other power system objects). This is normally the case in distribution networks for urban areas. The use of overcurrent relays as short-circuit protection in these cases can result in long functional time delays to assure selectivity. A better alternative in such cases is often to use current differential protection as line short-circuit protection. The current differential protection can serve as protection for single phase to earth-faults as well.

**2.1.4****Radial high impedance grounded MV system**

In most cases it is sufficient to use simple non-directional phase overcurrent relays. Here RAHL is applicable. The time current characteristic should be selected according to common practice in the network. Normally the same time current characteristic is used for all phase overcurrent relays in the network. This includes phase overcurrent protection for lines, transformers and other equipment.

In some applications there are short lines, with other objects connected in series (other lines, transformers or other power system objects). This is normally the case in distribution networks for urban areas. The use of overcurrent relays as short-circuit protection in these cases can result in long functional time delays to assure selectivity. A better alternative in such cases is often to use current differential protection as line short-circuit protection.

In radial networks parallel lines sometimes are used. This means that we introduce meshed loops in networks that basically have radial structure. In the meshed loops it can be difficult, or even impossible, to achieve selectivity if non-directional overcurrent relays are used. One solution can be to use directional overcurrent relays for some terminals, as shown in figure 2.

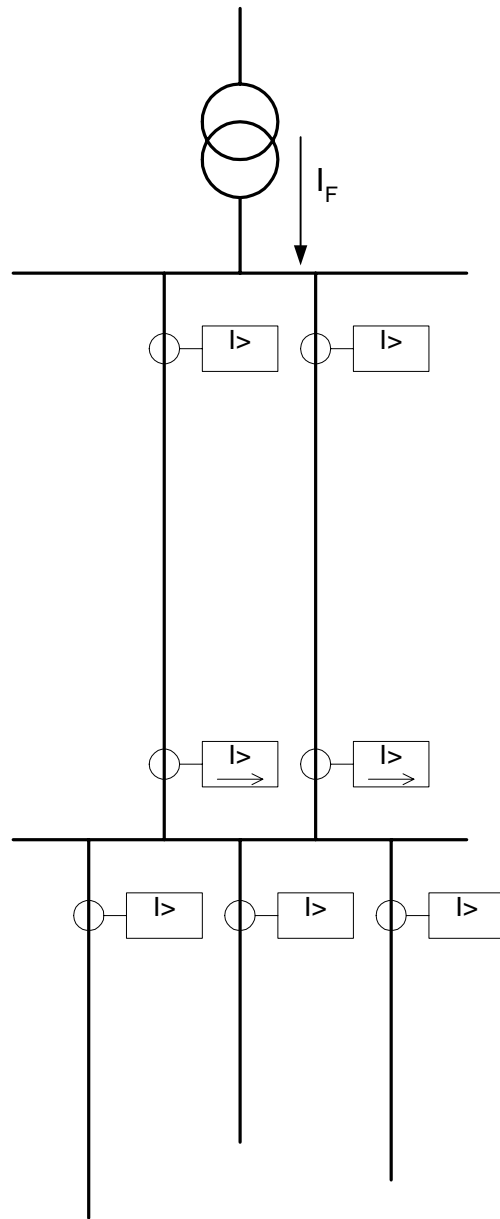

99001005.vsd

Figure 2: Radial network with a double circuit line having overcurrent protection

Even if this protection system can be used it can be difficult to find suitable settings so that requirements on fault clearance time and selectivity can be met. A better solution is often to use current differential line protection for the parallel lines, as shown in figure 3.

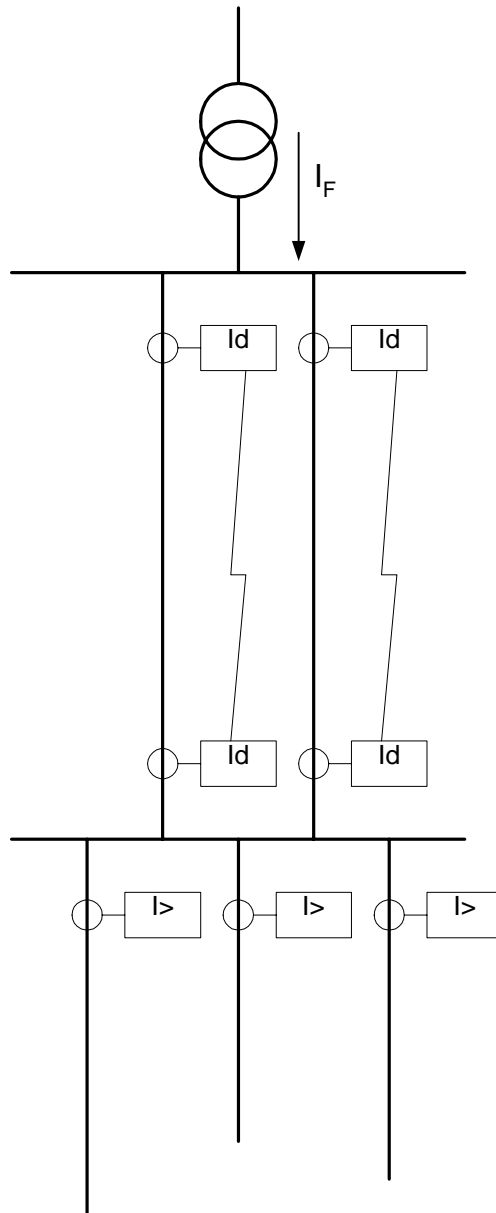

99001006.vsd

Figure 3: Radial network with a double circuit line having differential protection

### 2.1.5 **Meshed high impedance grounded MV system**

There is a possibility to use overcurrent protection in meshed systems as short-circuit protection. It must however be realized that the setting of a short-circuit protection system in meshed networks, can be very complicated and a large number of fault current calculations are needed. When of the computer software for protection coordination, available at the market today, is of great help in these situations. Still, there might be situations where there is no possibility to have selectivity with a protection system based on overcurrent relays, in a meshed system.

The normal selection for short-circuit protection in meshed networks would be to use a protection system based on distance protection. The distance protection should have both phase-phase measurement loops as well as phase to earth measurement loops. The number of zones to be used is dependent on the way back-up protection shall be arranged. If local back-up is used two or three zones are normally sufficient. If remote back-up protection shall be used, for example for back-up protection of transformers, three or even more zones are required.

In some applications there are short lines, with other objects connected in series (other lines, transformers or other power system objects). This is normally the case in distribution networks for urban areas. The use of overcurrent relays as short-circuit protection in these cases can result in long functional time delays to assure selectivity. A better alternative in such cases is often to use current differential protection as line short-circuit protection.

## 2.2 **Selection of type of earth-fault line protection in Medium Voltage (MV) networks**

### 2.2.1 **Radial single phase and solidly grounded Systems**

For low resistive earth-faults the phase overcurrent protection will serve as earth-fault protection.

For high resistive faults the detection of these faults are difficult. This is due to the fact that the earth-fault current has the same magnitude as the load current. There is research going on within this area.

### 2.2.2 **Radial solidly grounded MV system with three phase lines only**

For low resistive earth-faults the phase overcurrent protection will serve as earth-fault protection. Also residual overcurrent protection can be used as earth-fault protection.

For high resistive faults residual overcurrent protection can give sufficient sensitivity as this protection can be given a current setting considerably lower than the load current of the protected line.

**2.2.3****Radial high impedance grounded MV system**

In high impedance grounded networks the fault current, in case of single phase to earth-fault, is significantly smaller than the phase to phase short-circuit current. The neutral point voltage (zero sequence voltage) will adopt higher values, in case of earth-faults, in high impedance grounded networks compared to solidly grounded networks.

Overcurrent protection, fed by the residual current out on the feeder, can normally serve as earth-fault protection. There are some alternatives however in the selection of characteristics for the protection. The system grounding will influence this selection strongly.

In very small MV systems, with a small capacitance to ground it is suggested to use resistance grounding. There will be a well-defined resistive earth-fault current component (in phase with the residual voltage). If the resistive earth-fault current, at high resistive earth-faults, is larger than the capacitive earth-fault current fed from the feeder at zero resistive earth-faults in the network, non-directional earth-fault current protection can be used. In most cases it is however beneficial to use directional earth-fault current protection, measuring the active earth-fault current component.

For MV systems with only one or two feeders from the feeding transformer station it is suggested to use resistive grounding. This will assure that there will be a well-defined resistive earth-fault current (in phase with the residual voltage) out on the faulted feeder. Directional earth-fault current protection, measuring the resistive earth-fault current, should be used in this case. If the earth-fault current, emanating from the neutral point resistor, is large compared to the capacitive earth-fault current, non-directional earth-fault current protection can be used.

For MV systems with reactance grounding (Petersen coil system grounding), directional earth-fault current protection measuring the resistive earth-fault current should be used. It is necessary to have a neutral point resistor connected in parallel with the Petersen coil. The earth-fault current protection should have directional function, measuring the resistive component of the earth-fault current out on the feeder. If the earth-fault current should be minimized the neutral point resistor must be taken away. In such a case earth-fault current protection, detecting the transient from an earth-fault, can be used.

If possible, it is of economical reasons beneficial to operate the network with isolated neutral. In such cases directional earth-fault protection, sensitive for the capacitive earth-fault current, can be used. If the capacitive earth-fault current from the non-faulted feeders, at high resistive earth-faults, is larger than the capacitive earth-fault current fed from the feeder at zero resistive earth-fault in the network, non-directional earth-fault current protection can be used.

---

The non-directional earth-fault current protection function in RAHL 411 is applicable in the cases when non-directional earth-fault current protection can be used.

## 2.3

### Protection for cross-country faults

In high impedance grounded MV networks there is always a risk that a single phase to earth-fault in one phase will be followed by a second phase to earth-fault in another phase. This is due to the fact that the first earth-fault will give high phase to ground voltages in the non-faulted phases (healthy phases). If the insulation level is reduced somewhere in the network, the risk for a second fault is large. When the two phase to earth-faults hit different feeders in the network, this fault is called a “cross-country” fault.

The fault current magnitudes and phase angles are difficult to calculate for cross-country faults. In general terms it can be said that the fault current magnitude normally is larger than the single phase to earth-fault, but smaller than the phase to phase short-circuit current. After the second earth-fault has occurred there is a risk that the zero sequence voltage in the network will be low. Therefore there is a risk that a directional earth-fault current protection will not operate.

An alternative for cross-country fault protection is to use non-directional earth-fault current protection for the feeders. The current setting shall be lower than the short-circuit over current protection, and the time delay longer.

The non-directional earth-fault current protection function in RAHL 411 is applicable as cross-country fault protection.

## 2.4

### Blocking and enabling functions

The phase overcurrent protection and the earth-fault current protection can be used in combination with blocking and/or enabling functions. This can be a way to achieve short fault times for busbar faults or for faults on short lines. In figure 4 an example is shown where a blocking signal is used to enable short busbar fault time.

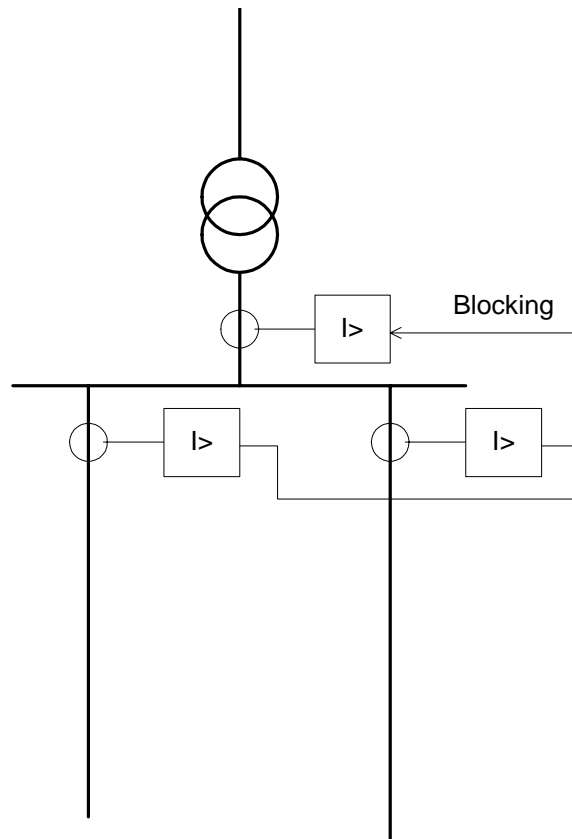

99001007.vsd

*Figure 4: Example of application with blocking function*

The overcurrent protection of the transformer has a high current stage with a short functional delay. This stage is blocked if a blocking signal is received from the feeder protections. In case of a fault on a feeder the blocking will assure selectivity. In case of a busbar fault the fault time will be relatively short.

Another example is when we have a small generating unit remote in the MV network. With reference to figure 5, assume a short-circuit on the feeder connecting to the generating plant. This will give rise to a comparatively small fault current from the plant.

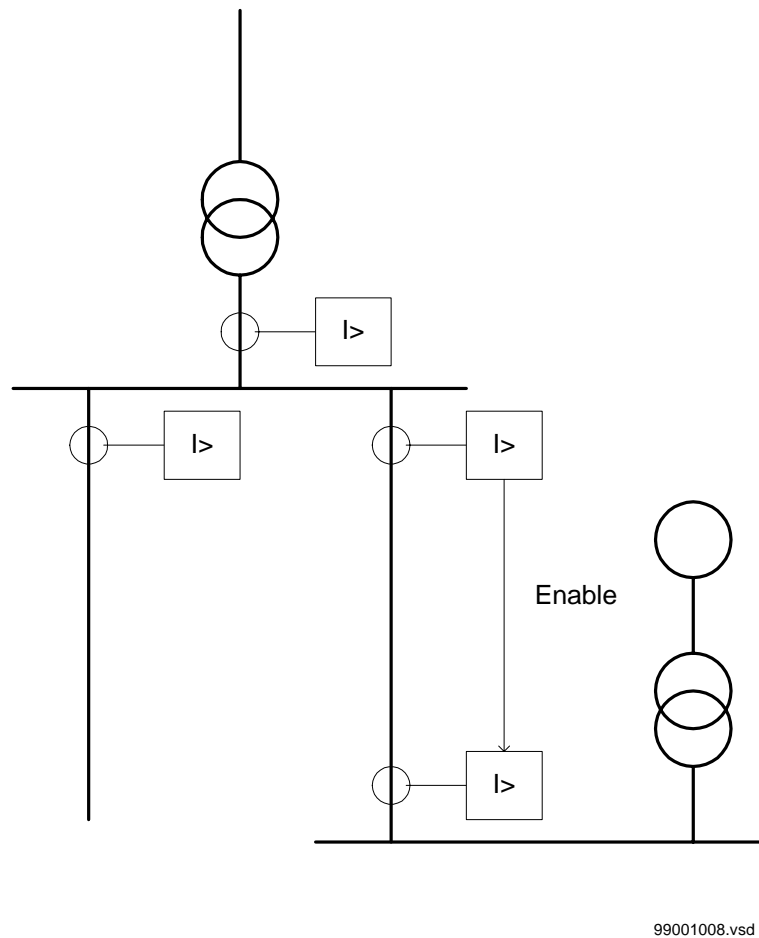

Figure 5: Example of application with enabling function

An enable signal is now sent from the feeder protection in the feeding station to the feeder protection in the generating plant station. The enable signal will activate an overcurrent protection stage with a low current setting. This will enable fault clearance from the relatively weak infeed from the power plant. An alternative to the remotely sent enabling signal can be a local under-voltage criterion.

RAHL is applicable for applications with blocking and/or enabling functions.

## 2.5

### Intentional overreach

In some applications an intentional overreach of the short-circuit (earth-fault) protection can be used. This function is used in combination with rapid automatic reclosing. The function can be described as follows:

---

When a short-circuit occurs within an overreach zone (current or impedance setting so that faults outside the line is detected) an instantaneous, or very shortly delayed, trip of the line is initiated. This trip is not selective as the relay is set to overreach at the first trip. After a short delay the rapid autoreclosing is performed and the protection setting is switched to a normal setting (selective to other protection). In case of a permanent fault the line will be tripped after normal operation time. If the fault is transient the line will stay in operation after the reclosing.

The function is used in the following applications:

- Limitation of thermal stress of equipment in case of a permanent fault. In such a case the total fault time will be the combination of one instantaneous trip and one delayed trip instead of two delayed trips
- Saving of fuses remote on the feeders in MV networks. In case of a transient fault out in the system the short-circuit protection will give a trip so fast so that the fuses between the feeding point and the fault will not blow. If the fault is transient the operation will continue after the rapid autoreclosing.

For RAHL the function can be set to have the first trip, before reclosing, initiated of the low set, medium set or high set current criterion. There is also a possibility to have a short delay of the function in order to achieve selectivity to fuses connected to the feeder.

## 2.6 Time characteristics

To achieve selective fault clearing the different protections and stages have to have different time delays. Several different time characteristics are available. They are described below and some general guide-lines are given. However, as a general rule, different time characteristics should not be used in one and the same system if not necessary. An appropriate characteristic is therefore selected on the basis of previous practice.

### 2.6.1 Definite-time characteristic

The operate time is independent of the fault current magnitude. The time co-ordination, between relays in series, is easier than for inverse characteristic but the time delay often will be unnecessarily long, especially when there are several over-current relays in series in the system. The short-circuit power should not vary too much when using the definite-time characteristic.

### 2.6.2 Inverse time characteristic

The operate time is dependent of the fault current magnitude. For the co-ordination between the relays the inverse time characteristic is beneficial.

There are three standard (IEC) inverse time curves: normal, very and extremely inverse. The additional curve, long-time inverse, uses the same formula as the standard IEC curves. The relationship between current and time on the standard curves complies with the standard IEC 60255-3 and can generally be expressed as:

$$t = \frac{k \cdot \beta}{\left(\frac{I}{I_{>}}\right)^{\alpha} - 1}$$

where:

t = operating time in seconds

k = settable inverse time factor

I = measured current value

I<sub>></sub> = set current value

α = index characterizing the algebraic function

β = constant characterizing the relay

The characteristic is determined by the values of the constants α and β:

Characteristic	α	β
Normal inverse	0.02	0.14
Very inverse	1.0	13.5
Extremely inverse	2.0	80.0
Long-time inverse	1.0	120.0

According to the standard IEC 60255-3 the normal current range is defined as 2 - 20 times the setting. Additionally, the relay must start at the latest when the current exceeds a value of 1.3 times the set start value.

The characteristic of the RAHL satisfies the defined function in the standard at least down to 1.3 times the setting.

The time characteristics described below are available for the phase over-current protection function in RAHL.

**2.6.3 Normal inverse characteristic**

Normal inverse characteristic is suitable in systems with a large variation in short-circuit power fault currents for different fault locations. The characteristic is shown in the chapter “Design description”.

**2.6.4 Very inverse characteristic**

The operate time is more dependent of the fault current magnitude. Very inverse gives a steeper curve than normal inverse and gives advantages in achieving selectivity between incoming and outgoing bays (meshed systems) with small difference in fault current. The characteristic is shown in the chapter “Design description”.

**2.6.5 Extremely inverse characteristic**

The operate time is very dependent of the fault current magnitude. This characteristic is intended for co-ordination with fuses on distribution or industrial circuits. The fuses are used in situations requiring a high degree of overload capacity utilization and where cold-load pick-up or energizing transient currents can be a problem. The characteristic is shown in the chapter “Design description”.

**2.6.6 Long-time inverse characteristic**

This characteristic has the same current dependence as the Very inverse characteristic. It is used when longer time delays are desired. The characteristic is shown in the chapter “Design description”.

**2.6.7 RI inverse characteristic**

This characteristic is provided for applications requiring co-ordination with the original ASEA type RI electromechanical inverse time relays. The relationship between current and time for this curve complies with the following formula:

$$t = \frac{k}{\left(0.339 - \frac{0.236}{I >}\right)}$$

Where:

t = operating time in seconds

k = settable inverse time factor

I = measured current value

I> = set current value

---

The characteristic is shown in the chapter “Design description”.

## 2.7

### Selectivity

In radially fed networks the way to achieve selectivity can be described as follows. In order to obtain selective tripping of the series connected circuit-breakers in the network, the time delay setting must increase for each step towards the infeed point, if pure time selectivity is used. This means that the tripping times will be longer the closer to the feeding point in the network the overcurrent relay is placed, but at the same time the short-circuit currents are increasing. It is therefore important that the time intervals between the different selectivity stages are the shortest possible. The minimum time interval between relays, to be selective to each other, is dependent of the following factors: the difference in pick up time of the relays, the circuit-breaker opening time and the relay resetting time. If definite-time characteristic is used, 0.3 s is usually recommended as a minimum time interval when the same types of relays are used.

It is easier to combine short fault clearance times with selectivity if combined current-time selectivity is used. In figure 6 it is shown how selectivity in a radial network can be realized with definite time and inverse time overcurrent protection.

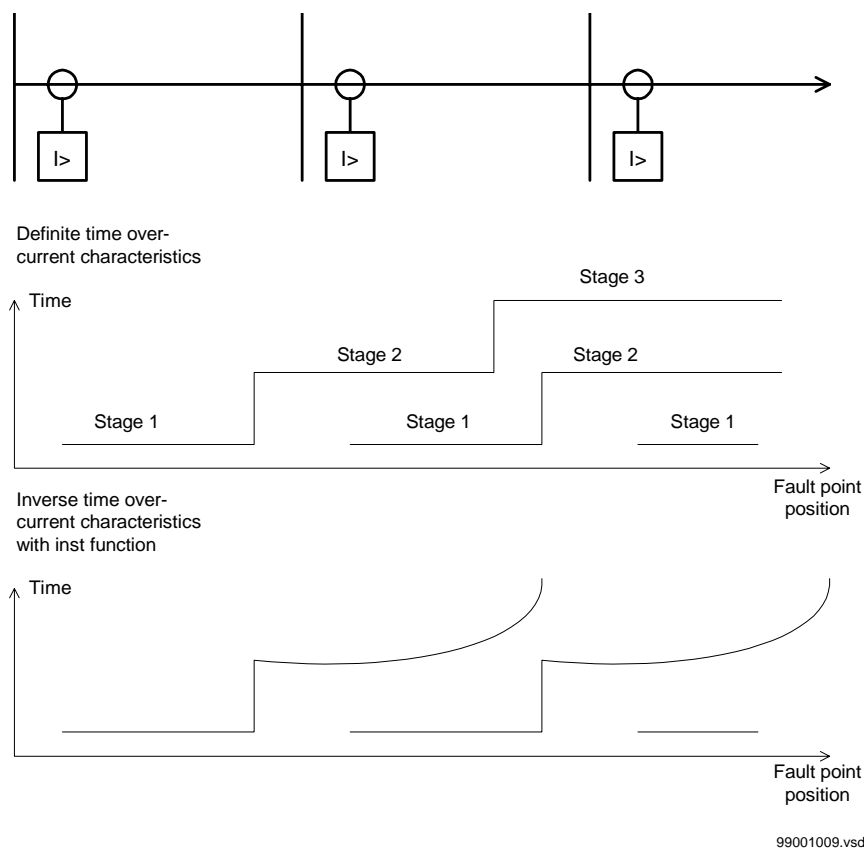

Figure 6: Fault time as a function of fault position in a radial network with overcurrent protection

The time interval has to be longer when using inverse characteristic, due to anticipated larger spread in the time function between different relays in the system, compared to the definite-time. To be on the safe side a time interval of 0.4 s is sufficient for normal inverse, very inverse and extremely inverse characteristics at a current corresponding to the highest through-fault current or possibly the current that corresponds to the setting of the instantaneous operation if this function is used.

To assure selectivity between different protections in a radial network, there has to be a minimum time difference  $\Delta t$  between the time delays of two following protections. The minimum time difference can be determined for different cases. To determine the shortest possible time difference we must know the operation time of relays, breaker opening times, relays inaccuracy measuring times and relays resetting times. These time delays can vary significantly between different devices of equipment. The following time delays can be estimated:

- Relay operation time: 15 - 60 ms
- Relay resetting time: 15 - 60 ms
- Breaker opening time: 20 - 120 ms
- Relay inaccuracy measuring time: 50 - 100 ms

Assume two substations A and B directly connected to each other via one line, as shown in figure 7. We study a fault located at another line from the station B. The fault current to the overcurrent relay of terminal B1 has a magnitude so that the protection will have instantaneous function. The overcurrent protection of terminal A1 must have a delayed function. The sequence of events during the fault can be described using a time axis.

- $t = 0$     The fault occurs
- $t = t_1$     The trip signal from the distance relay at terminal B1 is sent. Operation time of zone 1 operation of the distance relay is  $t_1$ .
- $t = t_2$     The circuit breaker at terminal B1 opens. The circuit breaker opening time is  $t_2 - t_1$ .
- $t = t_3$     The distance relay at terminal A1 resets. The relay resetting time is  $t_3 - t_2$ .

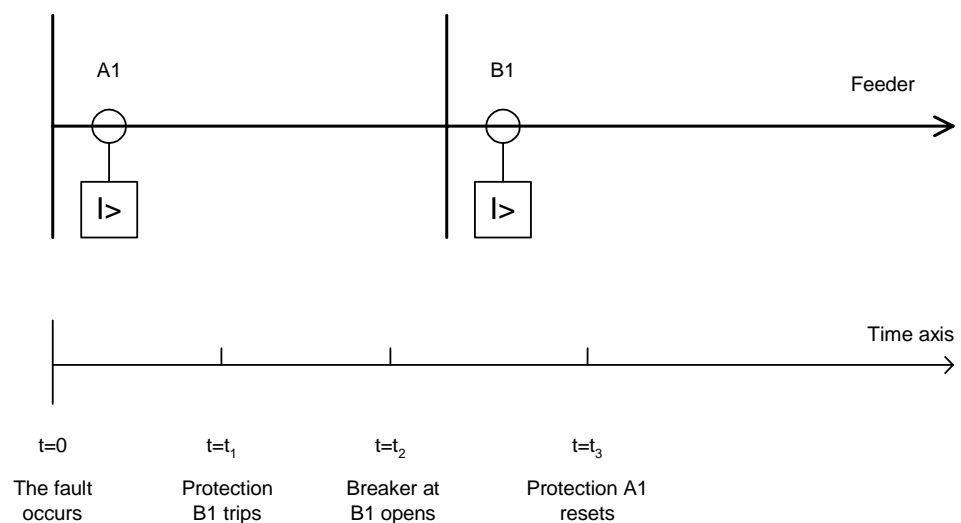

99001010.vsd

Figure 7: Example for estimation of selectivity time

---

To ensure that the overcurrent protection at terminal A1, is selective to the overcurrent protection at terminal B1, the minimum time difference must be larger than the time  $t_3$ . There are uncertainties in the values of breaker opening time and relay resetting time. Therefore a safety margin has to be included. With normal values the needed time difference can be calculated:

$$\Delta t \geq 40\text{ms} + 100\text{ms} + 40\text{ms} + 100\text{ms} + 40\text{ms} = 320\text{ms}$$

Where the following is considered:

- Operation time of overcurrent protection B1: 40 ms
- Breaker open time: 100 ms
- Reset time of protection A1: 40 ms
- Inaccuracy measuring time: 100 ms
- Additional margin: 40 ms

Due to the microprocessor timing accuracy, these new relays can generally be used with a tighter co-ordination margin than required for earlier static and electromechanical relays. When in doubt, please consult ABB.

## 2.8 Setting of phase overcurrent short-circuit protection in radial networks

### 2.8.1 Current Setting

The pick up current setting (inverse time relays) or the lowest current step (definite time relays) must be given a current setting so that the highest possible load current does not cause relay operation. Here consideration also has to be taken to the relay reset current, so that a short peak of overcurrent does not cause operation of the relay even when the overcurrent has ceased. This phenomenon is described in figure 8.

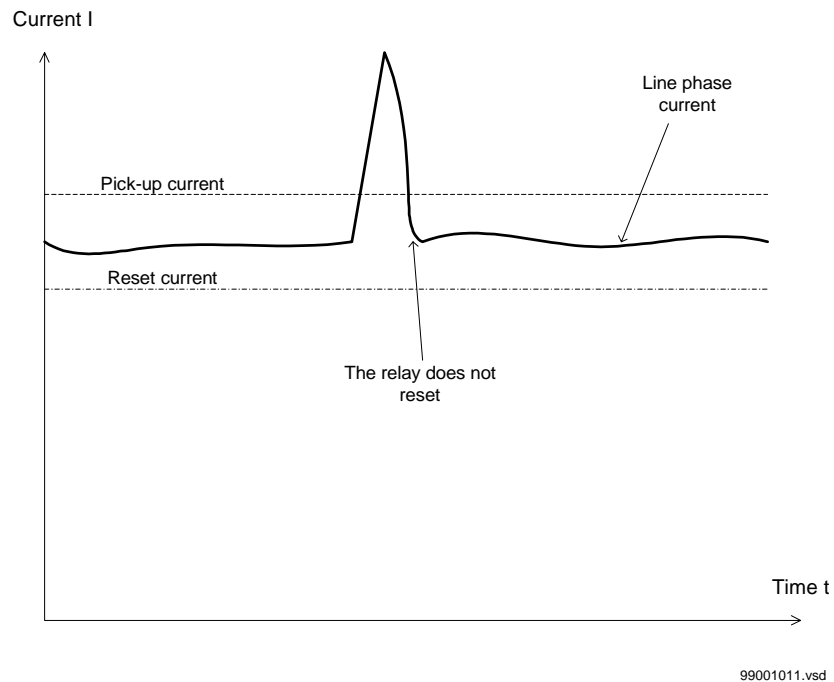

Figure 8: Clarification of reset current of overcurrent protection

The lowest setting value can be written:

$$I_{pu} \geq 1.2 \cdot \frac{I_{max}}{k}$$

Where:

1.2 = safety factor

k = resetting ratio of the relay

$I_{max}$  = maximum load current

The maximum load current on the line has to be estimated. From operation statistics the load current up to the present situation can be found. The current setting must be valid also for some years ahead. It is, in most cases, realistic that the setting values are updated not more often than once every five years. In many cases this time interval is still longer. There can be given two possibilities to determine the maximum load current to be considered in the setting of the relay:

- Contact the planning department of the utility and ask them to estimate the future maximum load current on the line. It can be valuable to have estimated values approximately five and ten years ahead.
- Investigate the maximum load current that different equipment on the line can withstand. Study components such as: line conductors, current transformers, circuit breakers, and disconnectors. The manufacturer of the equipment normally gives the maximum thermal load current of the equipment.

There is also a demand that all faults, within the zone that the protection shall cover, must be detected by the phase overcurrent relay. The minimum fault current  $I_{scmin}$ , to be detected by the relay, must be calculated. Taking this value as a base, the highest pick up current setting can be written:

$$I_{pu} \leq 0.7 \cdot I_{scmin}$$

Where:

0.7 = safety factor

$I_{scmin}$  = smallest fault current to be detected by the overcurrent protection

As a summary the pick up current shall be select within the interval:

$$1.2 \cdot \frac{I_{max}}{k} \leq I_{pu} \leq 0.7 \cdot I_{scmin}$$

The high current function of the overcurrent relay, which only has a short or no delay of the operation, must be given a current setting so that the relay is selective to other relays in the power system. It is desirable to have a rapid tripping of faults within as large portion as possible of the part of the power system to be protected by the relay (primary protected zone). A fault current calculation gives the largest fault current,  $I_{sc-max}$ , at the most remote part of the primary protected zone. Considerations have to be made to the risk of transient overreach, due to a possible DC component of the short-circuit current. The lowest current setting of the most rapid stage, of the phase overcurrent relay, can be written:

$$I_{high} \geq 1.2 \cdot k_f \cdot I_{scmax}$$

Where:

1.2 = safety factor

$k_f$  = a factor considering the transient overreach due to the DC component of the fault current

$I_{scmax}$  = the largest fault current at a fault at the most remote point of the primary protection zone

## 2.8.2

### Time setting

The operate times of the phase-overcurrent relay have to be selected so that the fault time is so short so that equipment will not be destroyed due to thermal overload, at the same time as selectivity is assured. For overcurrent protection, in a radial fed network, the time setting can be selected in a graphical way. This is mostly used in the case of inverse time overcurrent relays. Figure 9 shows how the time/current-curves are plotted in a diagram. The time setting is selected to get the shortest fault time with maintained selectivity. Selectivity is assured if the time difference between the curves is larger than a critical time difference.

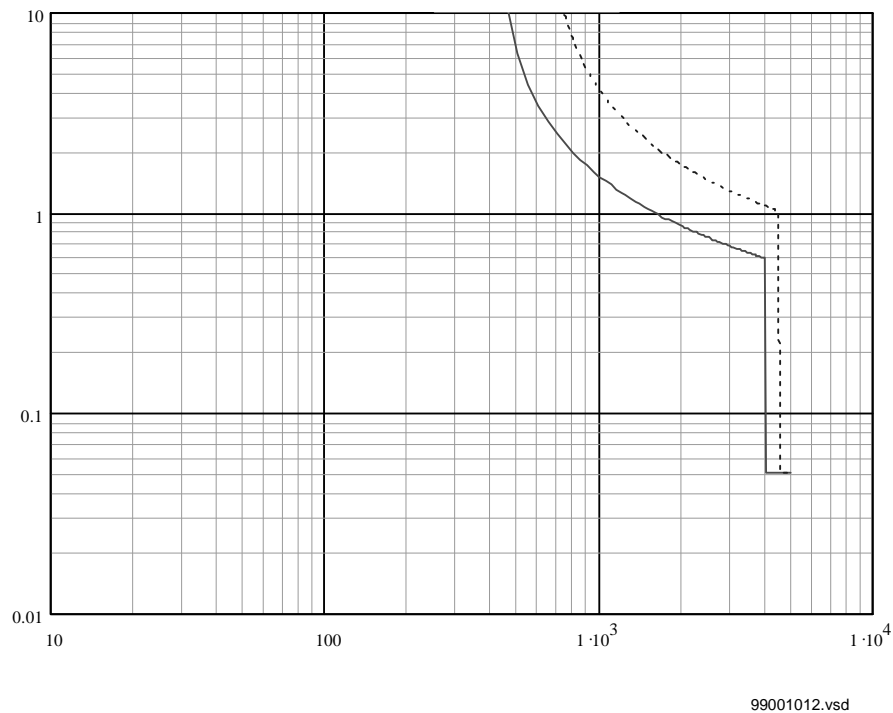

Figure 9: Example of time-current selectivity curves

## 2.9

### Back-up protection

In meshed systems overcurrent relays can be used as back-up protection for phase to phase short-circuits and phase to ground short-circuits on transmission lines. A very simple way to realize this kind of back-up protection scheme is to use a two stage overcurrent relay. The high current stage, with short time delay for operation, is given a current setting to assure selectivity. In practice this means that this stage will normally only cover a small portion of the line. The low current stage, with a longer time delay for operation, is given a current setting so that the whole transmission line is covered. The difficulty with this kind of back-up protection is that the settings must be valid for different operation states of the system, with different fault current levels.

A more sophisticated back-up protection scheme can be realized as described below: In meshed systems which are supplied from several directions (figure 10), the current sensed by the relays during a fault will vary considerably. In such cases, inverse time overcurrent protections which all have the same setting can be used as back-up protections. This provides good results since the fault current to the faulty line will always be higher than the fault current fed from the faultless lines, and therefore give the shortest tripping time. There can however be some difficulties in case of small substations, for example stations with only two connected feeders. With a fault on one of the feeders, the feeders will have the same fault current.

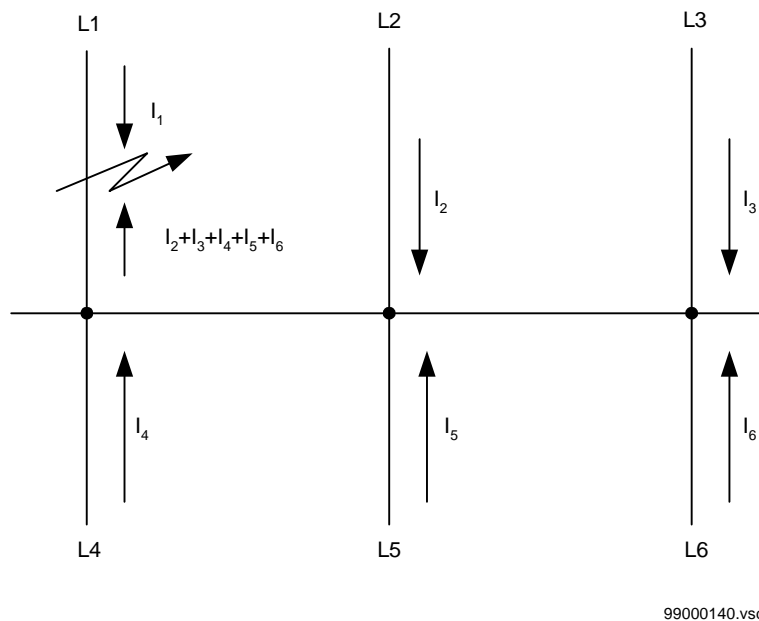

Figure 10: System with several supply circuits

In radial distribution systems normally the overcurrent protection for the supply transformer shall serve as back-up protection for the feeders. In many stations the combination of high rated power of the transformer and long feeders makes it impossible to achieve acceptable back-up function to a large extent of the feeders. The problem will be even worse if two transformers operate in parallel.

To fulfil the basic requirement of back-up protection, the feeders that are lacking back-up function, should be equipped with a supplementary overcurrent protection, and breaker-failure protection.

**2.10****Three-phase versus two-phase overcurrent protection**

In power systems with high impedance grounding, large fault currents only occur in case of phase-to-phase and three-phase short-circuits. In case of such a fault there will be high current in at least two of the three phases during the short-circuit moment. In solidly grounded system high current can be a consequence also at single phase-to-earth short-circuits. Below is discussed the selection of three-phase versus two-phase overcurrent protection in systems with high impedance grounding.

In a three-phase overcurrent protective relay, both phase currents are always measured when a two-phase fault occurs. The relay operates, therefore, even if one of the measuring circuits should be faulty. A three-phase protection is therefore more dependable than a two-phase protection. Compared to a summing type of protection, that has a common measuring circuit, considerably greater dependability is achieved.

As there will always be fault currents in at least one of the phases during short-circuit, it is often quite adequate to use two-phase protection for the feeders. It is absolutely necessary that the overcurrent relays are located in the same phases all over the network. This is due to the demand to assure reliable detection of cross-country faults.

There is always a risk of cross-country faults. This means that there will be a phase to earth-fault in one phase for one feeder and in another phase for another feeder. If two phase over-current relays are used for the feeders in the system, there is a risk that the faulted phase on one of the feeders will be the non-protected phase. This can result in an unwanted delay of the fault clearance. If a three-phase over-current protection is used this risk will be eliminated.

In networks with low short-circuit power, three-phase relays may, in some cases, be necessary. In the event of a two-phase short-circuit on one side of a D/Y-connected transformer, full short-circuit current will only flow in one of the phases on the other side of the transformer. Approximately half the short-circuit current will flow in the other phases. If a protection had to detect a fault through the transformer and a two-phase short-circuit protection is used, the operation can be unreliable in this case.

### 3 Example of a selectivity plan

The settings of the overcurrent protections in a radial network are to be calculated. The relays have normal inverse characteristic and are located as shown in figure 11.

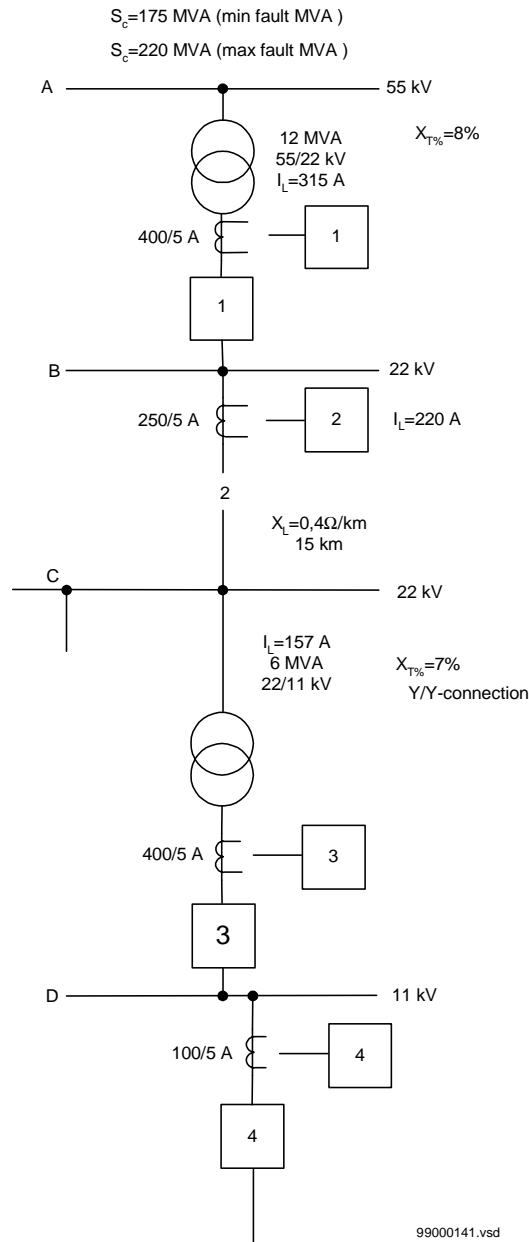

Figure 11: Radial network

Determine the equivalent impedance network related to the 22 kV level (figure 12) and calculate the fault currents, on the 22 kV voltage level. In the example all impedances are considered to be pure reactances.

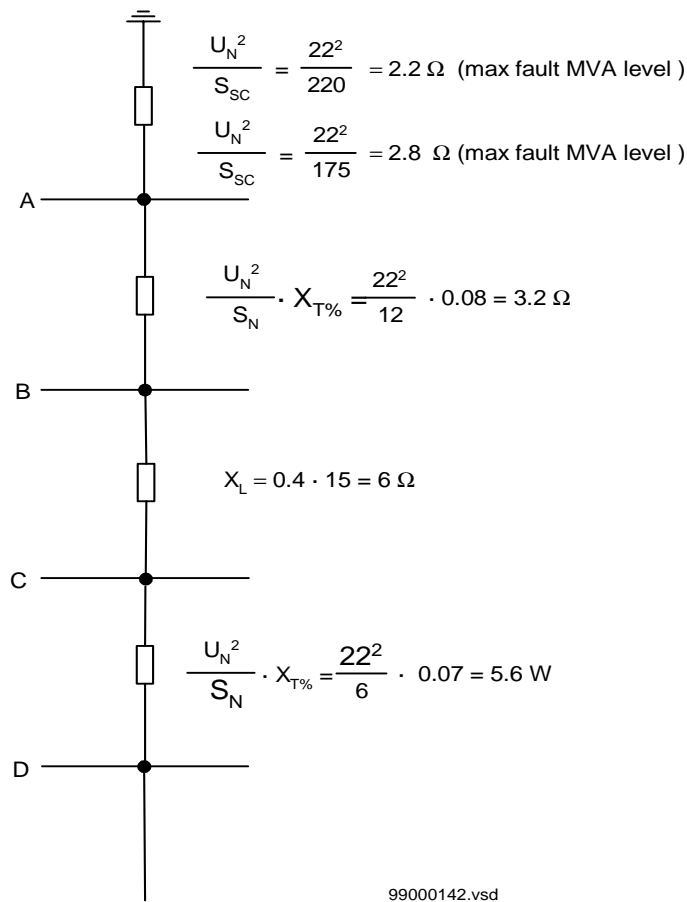

Figure 12: Equivalent impedance network

The short-circuit currents are calculated for different fault points in the system. This is done for both maximum and minimum short-circuit capacity.

Three-phase short-circuit current:

$$I_{sc} = \frac{22}{\sqrt{3} \cdot X_L}$$

$$I_{scA \max} = \frac{22}{\sqrt{3} \cdot 2.2}$$

$$I_{scB \max} = \frac{22}{\sqrt{3} \cdot (2.2 + 3.2)}$$

$$I_{scA \min} = \frac{22}{\sqrt{3} \cdot 2.8}$$

$$I_{scB \min} = \frac{22}{\sqrt{3} \cdot (2.8 + 3.2)}$$

The phase to phase short-circuit current can be found by multiplying the three phase short-circuit current by a factor:

$$\frac{\sqrt{3}}{2}$$

#### Max values

$$I_{scA} = 5\,770 \text{ A}$$

$$I_{scB} = 2\,350 \text{ A}$$

$$I_{scC} = 1\,110 \text{ A}$$

$$I_{scD} = 750 \text{ A}$$

#### Min values

$$I_{scA} = 4\,540 \text{ A}$$

$$I_{scB} = 2\,120 \text{ A}$$

$$I_{scC} = 1\,060 \text{ A}$$

$$I_{scD} = 720 \text{ A}$$

### 3.1

#### Relay 4

The present setting of relay 4 is retained. The primary setting, referred to 22 kV is given in the time curves in figure 13.

Low set stage  $I_{>} = 50 \text{ A}$

Medium set stage  $I_{>>} = 250 \text{ A}$

Inverse time factor  $k = 0.10$

Referred to the relay side:

$$I_{>} = 50 \cdot \frac{22}{11} \cdot \frac{5}{100} = 5 \text{ A}$$

$$I_{>>} = 250 \cdot \frac{22}{11} \cdot \frac{5}{100} = 25 \text{ A}$$

### 3.2

#### Relay 3

The rated current  $I_L$  of the power transformer is 315 A at 11 kV. The overload capacity of the transformer is considered to be 40%. A normal setting for the low set function is calculated:

$$I \geq \frac{1.4 \cdot I_L}{\eta} = \frac{1.4 \cdot 315}{0.9} = 490 \text{ A}$$

Where  $\eta$  is the resetting ratio of the relay. 500 A seems to be a reasonable choice for current setting of the low set stage. It shall be observed that the protection in this case will be a short-circuit protection and not an overload protection.

Low set stage:

$$I_{>} = 500 \cdot \frac{5}{400} = 6.25 \text{ A}$$

Referred to 22 kV the low set stage will be:

$$I_{>} = 500 \cdot \frac{11}{22} = 250 \text{ A}$$

The medium set stage must be blocked in order to achieve selectivity for faults on outgoing lines from D. To co-ordinate the time delay, the inverse time factor  $k = 0.05$  is chosen from the time curve in figure 13.

### 3.3

#### Relay 2

This relay constitutes a back-up protection for faults occurring on busbar D. Determine the minimum two-phase fault current on busbar D:

$$I_{sc \min} = 720 \cdot \frac{\sqrt{3}}{2} = 620 \text{ A}$$

The maximum setting of low set stage to assure fault clearance at busbar D:

$$I_{>} = 0.7 \cdot I_{sc \min} = 0.7 \cdot 620 = 430 \text{ A}$$

Select the low set stage setting  $I_{>} = 300 \text{ A}$  in order to obtain a good margin to the load current for the feeder  $I_L = 220 \text{ A}$ . The medium set stage must be selective with respect to relays for feeders from busbar C.

Select  $I_{>>} = 1.2 \cdot 750 = 900 \text{ A}$  and the medium set stage time delay as short as possible (approximately 30 ms).

Select  $k = 0.10$  from the time curve in figure 13.

Low set stage:

$$I_{>} = 300 \cdot \frac{5}{250} = 6 \text{ A}$$

Medium set stage:

$$I_{>>} = 900 \cdot \frac{5}{250} = 18 \text{ A}$$

### 3.4

#### Relay 1

The primary setting of the low set stage is:

$$I_{>} = 315 \cdot 1.6 = 500 \text{ A}$$

The relay constitutes a back-up protection for faults which occur up to breaker 3. In the case of faults close to the breaker the safety factor in respect of a two-phase fault will be:

$$\frac{720 \cdot \frac{\sqrt{3}}{2}}{500} = 1.25$$

Select  $k = 0.10$  from the time curve in figure 13.

As the instantaneous function can not be used the medium set stage has to be blocked.

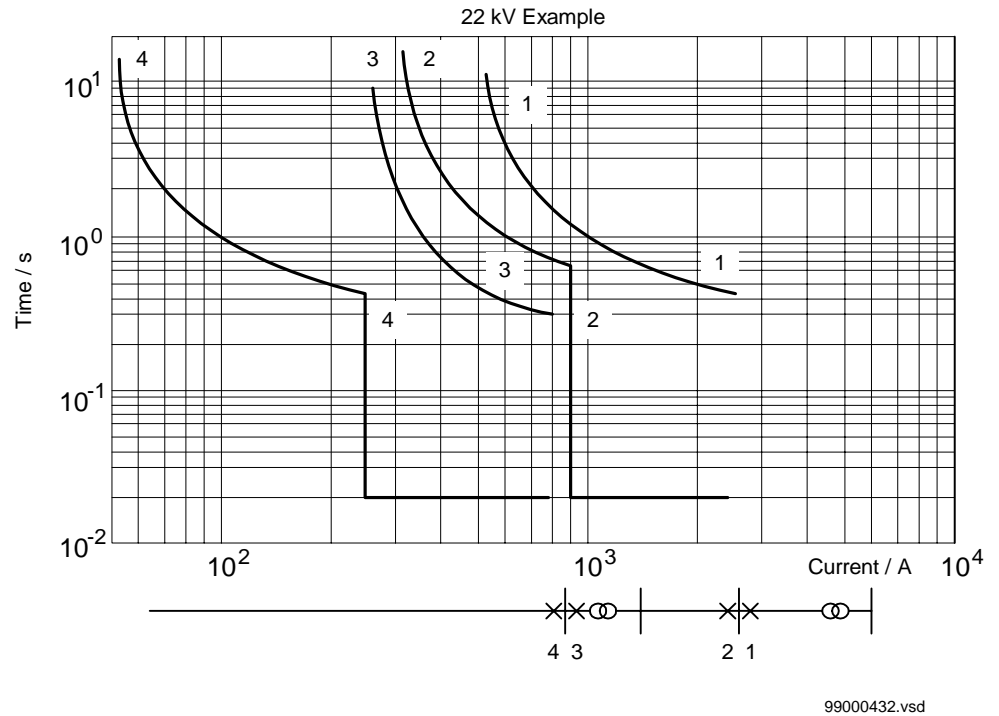

Figure 13: Current-time characteristics for the studied network

## 4 Thermal overload protection

All electrical conductors have a certain resistance, which gives rise to an active power loss  $I^2 \cdot r$ , where  $I$  is the rms value of the current and  $r$  is the resistance of the conductor. Hence the active power loss is proportional to the square of the current and inversely proportional to the cross-sectional area of the conductor.

The phase current conductors in cables, motors, generators, transformers, reactors etc. are surrounded by insulating material which deteriorates rapidly if the temperature exceeds the design limit value. As a rule of the thumb, the useful life time of the insulation material will be reduced to the half of the design value for each continuous increment of the temperature of the conductor by 7 degrees centigrade above rated value.

The temperature rise of a body which is heated from a source of constant energy is according to the equation:

$$\theta(t) = \theta_s - (\theta_s - \theta_p)e^{-t/\tau}$$

When the heat energy is decreased, the following equation is valid:

$$\theta(t) = \theta_s + (\theta_0 - \theta_s)e^{-t/\tau}$$

Where:

$\theta(t)$  = the temperature as a function of time for the body

$\theta_s$  = the final, steady state temperature

$\theta_p$  = the temperature at the moment when the power is increased

$\theta_0$  = the temperature at the moment when the power is reduced

$\tau$  = the thermal time constant

Figure 14 shows the temperature rise as function of time when a conductor carries current which gives a final temperature rise of  $\theta_s$ . Figure 15 shows the corresponding rise of temperature when the conductor carries a load = 1.5 times this current.

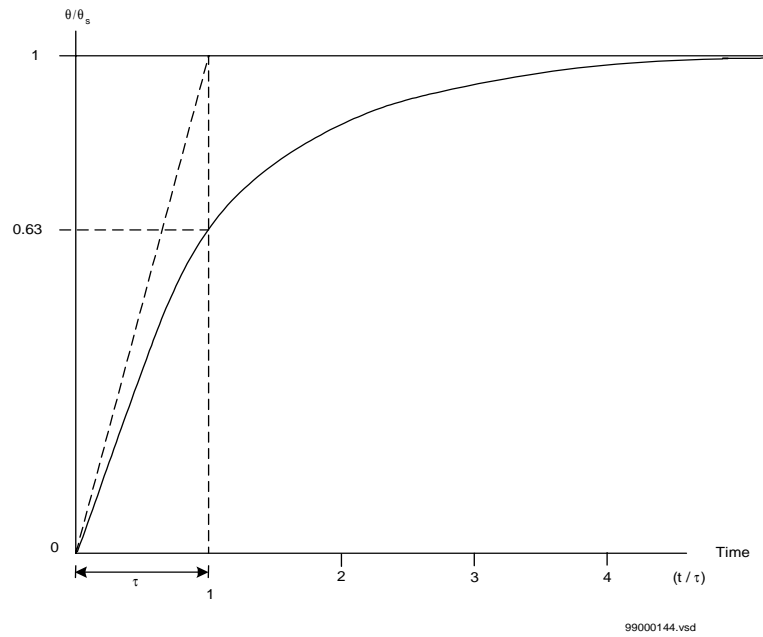

Figure 14: Temperature rise at rated current

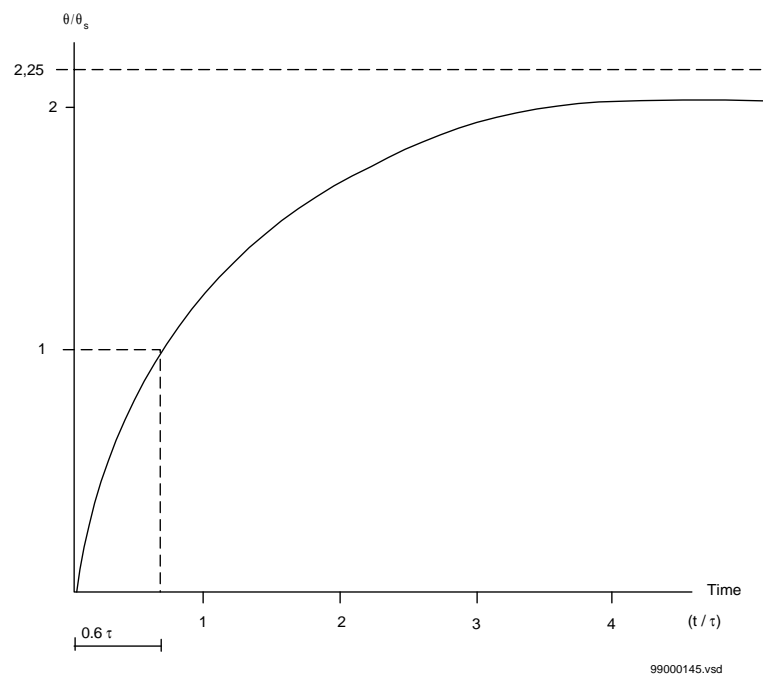

Figure 15: Temperature rise at 1.5 times rated current

Overloads up to 1.4 times rated current are normally not detected by the short-circuit overcurrent or impedance relays. A sustained overload of 1.2 times rated current gives a temperature increase of  $1.2^2 = 1.44$  times the temperature increase at rated current. For large generators, motors, transformers and reactors, thermal overloading of the windings will be detected by temperature monitors. For apparatuses without thermal detectors, an accurate thermal relay with operating characteristics giving a thermal replica of the winding will provide a thermal overload protection. For apparatuses with thermal detectors, a thermal overload protection will provide a back-up function.

Electrical cables which can be loaded up to the permissible thermal load current should be provided with both thermal and short-circuit protection. For cables surrounded by air, the thermal time constant  $\tau$  can vary from some few minutes for 10 kV cables with cross-sectional area  $25 \text{ mm}^2$  to one hour for 30 kV cables with cross-sectional area  $> 185 \text{ mm}^2$ .

The shorter time constant valid for cables placed in air will normally be decisive, since some part of the cable normally will be surrounded by air.

For overhead lines the temperature of the conductor is a little more complicated to analyze compared to the above described power system components. The temperature dynamics of an overhead line conductor can be described by the following differential equation:

$$\frac{d\theta_c}{dt} = \frac{1}{m \cdot c} \cdot (Q_H + Q_S - Q_R - Q_C)$$

Where:

$\theta_c$  = the conductor temperature

$m$  = the mass per length of the conductor

$c$  = the heat capacitivity of the conductor

$Q_H$  = the resistive power loss of the conductor

$Q_S$  = the incoming radiant power (from the sun)

$Q_R$  = the outgoing radiant power (dependent on the conductor temperature relative to the ambient temperature)

$Q_C$  = the outgoing convection power

If the temperature of the conductor increases the metal of the conductor will expand. As a consequence the sag of an overhead line will increase. If the temperature reaches a critical value the conductor material will be destroyed and the consequence will be that the conductors must be changed.

There is often large economic benefit to be able to operate lines with as large transmitted power as possible. At the same time a destroyed conductor will give large cost. It is therefore desirable to have some kind of thermal overload protection of lines

As we have seen above the temperature of the conductor is dependent on a number of factors. Therefore a thermal overload protection should have more input parameters than the load current only. In reality this is normally not possible. We must often use an overload protection only with current as input parameter.

## 4.1

### Settings

The thermal overload protection has a time current characteristics which follows the equation:

$$t = \tau \cdot \ln \frac{I^2 - I_p^2}{I^2 - I_b^2}$$

Where:

$I$  = overload current

$I_p$  = current previous to the overload, assuming sufficient long time to reach steady-state temperature.

$I_b$  = set operate current

The current time curves in figure 16 show the operate time for currents which are given as multiples of the set operate current  $I_b$ .

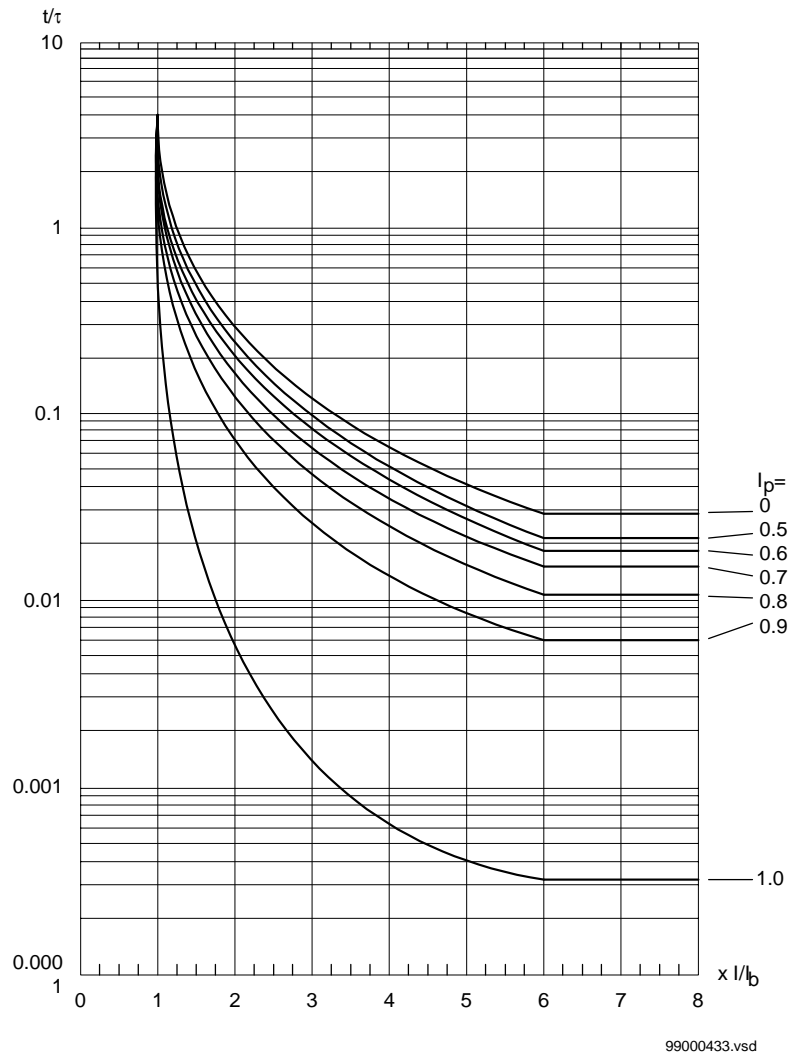

Figure 16: Operate time curves of the thermal protection

## 4.2

### Determining the time constant

For rotating machines the following can be said: In some cases, the current time capability curve is given instead of the thermal time constant  $\tau$ . A suitable thermal constant setting ( $\tau$ ) then must be decided by comparing some points on the capability curve with the operate time curves of the thermal overload protection. If the capability curve deviates from the relay operate curve, the lowest value of  $\tau$  is selected.

---

The thermal overload curve for a cold motor shows that 1.5 times rated load current is permissible for 18 minutes and 5 times rated current is permissible for 1 minute. From the relay operate curve, it is seen that the operate time is  $0.6 \cdot \tau$  at 1.5 times and  $0.04 \cdot \tau$  at 5 times rated current for a cold motor.

Hence, the  $\tau$  calculated from those two points would be  $18 \text{ minute}/0.6 = 30 \text{ minutes}$  respectively  $1 \text{ minute}/0.04 = 25 \text{ minutes}$ . The lowest value should be selected for the relay.

## 5 Earth-fault protection

The demands imposed on the earth-fault protection are dependent on system grounding and usually also on national requirements and previous practice.

All electrical power systems have a coupling to ground. The method of how the neutral points of the system are connected to the ground defines the system grounding.

The system grounding can be either ungrounded, high-impedance grounded, low-impedance grounded or solidly grounded. The grounding methods will influence the earth-fault current and therefore also the selection of the earth-fault protection. The magnitude of earth-fault current will vary widely from less than one ampere to several kilo-amperes depending on the grounding methods. This implies that the demands imposed on the earth-fault protection vary considerably.

### 5.1 Earth-fault protection in ungrounded or high-impedance grounded system

An ungrounded system does not have any neutral-point equipment that influences the earth-fault current. Voltage transformers and surge arresters may connect phase conductors and transformer neutral points to ground. The system is coupled to ground via the distributed capacitance to ground of the overhead lines and cables in the system. In these systems the earth-fault currents are an order of magnitude smaller than the short-circuit currents and the shunt impedances determine the earth-fault currents. An earth-fault with zero fault resistance will give a capacitive earth-fault current and the magnitude is determined of the size of the capacitance. Networks with small extension can give earth-fault currents that are less than one ampere.

For ungrounded or high-impedance grounded systems the residual voltage will be three times the phase voltage all over the system, in case of a phase-to-earth-fault with zero fault resistance. Often there are demands on the protections to be able to clear faults even if there is a considerable fault resistance. In Sweden, for example, the earth-fault protections sometimes shall be able to clear faults even if the fault resistance is 5000 ohm. The fault resistance will reduce the residual voltage considerable.

The complex residual voltage (zero sequence) and earth-fault current, can be calculated as follows:

$$V_0 = \frac{V_{\text{Phase}}}{1 + \frac{3R_f}{Z_0}}$$

Here  $V_{\text{Phase}}$  is equal to the phase to ground voltage before the fault,  $R_f$  is equal to the fault resistance and  $Z_0$  is the MV system zero sequence impedance to ground.  $Z_0$  can be expressed as:

Ungrounded system:

$$Z_0 = -jX_c$$

Where:

$X_c$  = the system capacitive reactance to ground

Resistance grounded system:

$$Z_0 = \frac{-jX_c \cdot 3R_n}{-jX_c + 3R_n}$$

Where:

$R_n$  = the resistance of the neutral point resistor

Reactance-resistance grounded system:

$$Z_0 = \frac{j(3X_n - X_c) \cdot 3R_n}{j(3X_n - X_c) + 3R_n}$$

Where:

$X_n$  = the reactance of the neutral point reactor (Petersen coil)

A alternative way to express the neutral point voltage is to express the development of the earth-fault:

$$\frac{V_0}{V_{\text{Phase}}} = \frac{1}{1 + \frac{3R_f}{Z_0}}$$

The total complex earth-fault current, in the fault point, can be expressed as:

$$I_j = 3I_0 = \frac{3V_{\text{Phase}}}{Z_0 + 3R_f}$$

The earth-fault current through the terminal of the faulted feeder is equal to the total earth-fault current, as shown above, minus the capacitive earth-fault current emanating from the faulted feeder itself.

In many cases the feeders have directional earth-fault current protection, sensitive to the active earth-fault current, emanating from the neutral point resistor. This active earth-fault current can be expressed:

$$I_{j, \text{ active}} = \frac{V_0}{V_{\text{Phase}}} \cdot I_{Rn}$$

Where:

$I_{Rn}$  = the rated current of the neutral point resistor

In networks with extensive overhead lines and underground cable systems, the capacitive earth-fault current can be larger than 100 A and cause hazardous potential rise and develop considerable heat at the fault location. It is therefore not acceptable to operate ungrounded networks with very large capacitive earth-fault currents. It may be necessary to ground the system via special equipment, that is compensator reactors, connected to a transformer neutral, in order to reduce the earth-fault current. Special equipment, for example neutral point resistors, may be used to enable earth-faults to be cleared selectively and rapidly. In a high-impedance grounded system the neutral-point can be connected to ground via a resistor or both a resistor and a reactor. The shunt impedances of lines and cables to ground and the neutral point impedance determine the earth-fault currents.

It may be necessary to introduce a resistor if the contribution from the short distribution line is too small to operate directional earth-fault relays.

**5.1.1****Non-directional earth-fault current protection**

In some cases and radial systems, non-directional residual current protections can be used as earth-fault protections. The earth-fault protection has an independent time delay and selectivity is obtained by time-grading the different relays. The current setting normally corresponds to 10-40% of the maximum fault current and is the same for all relays in the system.

In the case of overhead lines, the capacitive current generated by the protected feeder itself, should not exceed 66% of the operate value set on the line protection. For cables, this value should not exceed 30% of the set value. Directional relays should be used for higher values of the capacitive current of the protected feeder

Depending on the configuration of the system, the different capacitive currents of the objects and the required sensitivity, directional earth-fault protections are often required.

Another application of the non-directional earth-fault protection is to detect cross-country faults. In this case the setting of the relay is higher than the capacitive earth-fault currents of the feeder. This means that this residual current protection does not operate for single-phase earth-faults. During normal operation the residual current is close to zero which means that the setting may be lower than the setting of the overcurrent protection. The current setting can also be set to a very low value but the delay of the function shall be set to a high value to assure selectivity for single phase-to-earth-faults.

The non-directional earth-fault overcurrent protection function can be realized by RAHL 411.

**5.1.2****Directional earth-fault current protection**

In ungrounded or high-impedance grounded systems where the capacitive current from the protected line is large compared to the set operate value, directional residual current protections can be used for earth-fault protection. The relay uses the residual voltage as a polarizing quantity. Directional earth-fault protections normally has a current measuring relay with independent time delay and a characteristic angle which can be selectable between  $\alpha = 0^\circ$  or  $\alpha = -90^\circ$ .

In ungrounded systems, the relay measures the capacitive current and the characteristic angle is set to  $\alpha = -90^\circ$ . In resistance grounded systems, the characteristic angle shall be set to  $\alpha = 0^\circ$  and the relay measures the resistive component of the earth-fault current.

In high-impedance grounded system with a neutral point reactor the directional earth-fault protections should measure the resistive component of the earth-fault current to achieve a reliable selectivity. For that reason, a resistor normally has to be connected in parallel with the neutral point reactor to get a sufficiently high active current to the directional relay. The characteristic angle shall be set to  $\alpha = 0^\circ$ .

The time delay settings of the earth-fault relays are chosen according to the same principles as for the overcurrent relay.

### 5.1.3

#### **Residual overvoltage protection**

The transformer is often provided with a residual overvoltage protection. This protection may be the main earth-fault protection for the busbar in the distribution system and the associated transformer windings. It may also provide back-up protection for the distribution feeders.

## 5.2

### **Earth-fault protection in low-impedance grounded system**

In a low-impedance grounded system, a separate resistor is connected to a transformer neutral point. In case of earth-faults the current from the neutral point resistor is significantly larger than the capacitive earth-fault current from overhead lines and cables in the system. The fault current can therefore be said to be generated from one point only. Selectivity is then achieved by time-grading the different earth-fault relays.

Normally, a sensitivity of 10-30% of the maximum fault current is required and this applies to all relays. An earth-fault relay can be included in the neutral point to serve as a supplement and back-up protection.

The current setting of the relay is often chosen to correspond with that which the neutral-point transformer can withstand continuously. It is also given a relatively long delay of between 10 and 30 seconds. This can be complicated with the long-time inverse characteristic.

## 5.3

### **Earth-fault protection in solidly grounded system**

In solidly grounded systems there is a direct connection between transformer neutral points and the ground. The earth-fault currents can be of the same order of magnitude as the short-circuit currents and the series impedances determine the earth-fault currents. A fault-resistance can reduce the earth-fault currents considerably. Often the residual voltage is very small.

Except for measuring the residual current instead of the phase current the same principles and design of the earth-fault protection can be used in solidly grounded radial systems as for short-circuit overcurrent protection.

---

In meshed transmission systems distance protections are often used to clear earth-faults. In many cases, however the fault resistance is much higher than the resistance that can be covered by an impedance measuring distance relay.

Earth-faults with high fault resistance can be detected by measuring the residual current. This type of protection provides maximum sensitivity to earth-faults with additional resistance.

Directional earth-fault protection is obtained by measuring the residual current and the angle between the residual current and the residual voltage. As a general rule, selectivity, is more easily obtained by using the directional instead of the non-directional earth-fault overcurrent protection. High resistive earth-faults can also be detected by a sensitive directional protection, the limiting condition being that sufficient polarizing voltage must be available.

At the relay site, the residual current lags the residual voltage by a phase angle that is equal to the angle of the zero-sequence source impedance. In solidly grounded systems, this angle will be in the range of  $40^\circ$  to nearly  $90^\circ$ . To obtain maximum sensitivity under all conditions, the measuring relay should have a characteristic angle of approximately  $65^\circ$ .

The non-directional earth-fault current protection in the relay can, in some cases, be used as a simplified earth-fault protection, particularly as back-up protection. In this case the function is not directional.

Often a directional earth-fault protection function is required. In this application it is not possible to use a voltage memory method to decide the direction because there is no zero-sequence voltage before the fault has occurred.

In many applications a directional function of the residual overcurrent protection is desirable. In such cases the protection can be used in combination with the directional relay RXPDK 23H, that will provide enable criteria in case of earth-faults in the forward direction.

Both inverse time characteristics protection as well as three step definite time characteristics are used. If inverse time characteristics are used with equal current and time settings for all residual current protections in the system the selectivity is normally assured as long as there are more than two bays carrying fault current to each substation.

It is also possible to use the protection as a multi-stage earth-fault current line protection where the first stage has instantaneous function and covers most of the protected line. The second stage has a short delay (about 0.4 s) and covers the rest of the line. The third stage has a longer delay and will give relatively rapid and selective fault clearance of high resistive phase to earth-faults.

It is often required to clear earth-faults with residual currents of magnitudes which are as low as 50-100 A. Small residual currents normally occur when there are high resistance faults or series faults.

A serial fault can be caused by interruption of one or two phase-conductors with no contact to ground, or pole discrepancy in a circuit-breaker or a disconnecter. The most common type of serial fault is pole discrepancy at breaker maneuvering.

A sensitive non-directional inverse time residual overcurrent protection is a suitable solution to get a selective protection in most cases. It is possible to use the standard inverse time characteristics described in the overcurrent protection application section. A logarithmic characteristic is generally the most suitable for the purpose of selectivity, since the time difference is constant for a given ratio between the currents. The logarithmic inverse time characteristic is designed to achieve optimum selectivity. This relay is used extensively in, for example the Swedish 400 kV power transmission system. The same type of inverse time-current characteristic should be used for all earth-fault overcurrent protections in the network. Therefore, in networks already equipped with earth-fault overcurrent relays, the best selectivity will normally be achieved by using the same type of characteristic as that in the existing relays.

The logarithmic inverse time characteristic is defined in the formula:

$$t = 5.8 - 1.35 \cdot \ln \frac{I_N}{I_{N>}}$$

Where:

$t$  = operating time in seconds

$I_N$  = measured current value

$I_{N>}$  = set current value

The characteristic is shown in the chapter “Design description”.

The selectivity is ensured when the largest infeed is less than 80% of the current on the faulty line. The settings for all objects shall be the same.

To detect high resistive earth-faults, a low operating current is required. On the other hand, a low setting will increase the risk for unwanted operation due to unbalance in the network and the current transformer circuits. The minimum operating current of the earth-fault overcurrent protection must be set higher than the maximum false earth-fault current.

---

The unbalance in the network that causes false earth-fault current is caused mainly by untransposed or not fully transposed transmission lines. In case of parallel lines with strong zero-sequence mutual coupling the false earth-fault current can be still larger. The false earth-fault current is directly proportional to the load current.

In a well transposed system, the false earth-fault current is normally lower than 5% of the line current, except for extremely short parallel lines (less than 5 km), where a higher false earth-fault current may be found.

In case of extremely short or not fully transposed parallel lines, the false earth-fault current must be measured or calculated when maximum sensitivity is desired. Generally, 80 A is recommended as a minimum primary operating value for the earth-fault overcurrent protection.

### 5.3.1

#### **Second harmonic restraint operation with RAISB**

When energizing a solidly grounded power transformer, the residual inrush current can cause unwanted operation of the earth-fault overcurrent protection. In order to avoid restrictions on the settings, a second harmonic restraint relay type RAISB can be used for the earth-fault current protection. It blocks the operation if the residual current contains 20% or more of the second harmonic component.

## 5.4

### **Connection of earth-fault relay**

The current to the earth-fault relay can be connected in two different ways, by residual current connected line transformers or by using a separate open core current transformer.

In the case where the current transformers are residual current connected an unbalanced current can appear due to differences in the current transformers. In the event of a short-circuit, the unbalanced current can be of such a magnitude as to cause the operation of the earth-fault relay. This can be prevented if the operate time of the earth-fault relay is extended in relation to that of the short-circuit protection or if an open core current transformer is allowed to feed the earth-fault relay.

To reduce the unbalanced current in cases when the current transformers are residual current connected, the current summation must take place as near as possible to the current transformers. No other relays or instruments should be connected. If this cannot be avoided, the load should be symmetric and the burden low.

The directional earth-fault overcurrent relay shall also measure the zero sequence voltage. It is recommended to use the residual voltage measured in a three-phase voltage transformer connected in a broken delta. The residual voltage is three times the zero sequence voltage.

---

If a complete three-phase voltage transformer group is not available it is possible to use the neutral point voltage measured from a voltage transformer connected to the neutral point. This is a less reliable method and should not be recommended in the first place. Another disadvantage of this method is that an interruption or short-circuit of the secondary winding of the voltage transformer will not be detected during normal operation, as is the case with voltage transformers connected in a broken delta.

## 6 Breaker failure protection

This function issues a back-up trip to adjacent circuit-breakers in case of a tripping failure of the object circuit-breaker (CB), and clears the fault as requested by the object protection.

The breaker-failure protection is either started by an internal trip signal, from a protection or external via the binary input. Correct fault current clearing or the failure is detected by a current check in all phases. The current level for phase and earth-fault detection can be set within a wide range. An external start of the breaker-failure protection always generate an instantaneous re-trip signal without current check. The use of re-trip, limits the impact on the power system if the breaker-failure protection is started by mistake during testing or other maintenance work.

After the set time delay, the back-up trip signal should be connected to trip the adjacent circuit-breakers, to clear the busbar section and intertrip the remote end, if so required. The timer setting should be selected with a certain margin to allow variation in the normal fault clearing time. The properties of the breaker failure protection allows the user to use smaller margins. Figure 17 shows the fault clearance time at a breaker-failure situation.

The application functions of the breaker-failure protection are:

- Individual phase and earth-fault function
- Instantaneous re-trip at external start
- Time delay for the back-up trip of the adjacent circuit-breakers
- Accuracy of the timer and short reset time for the current elements, allowing the use of short back-up trip time

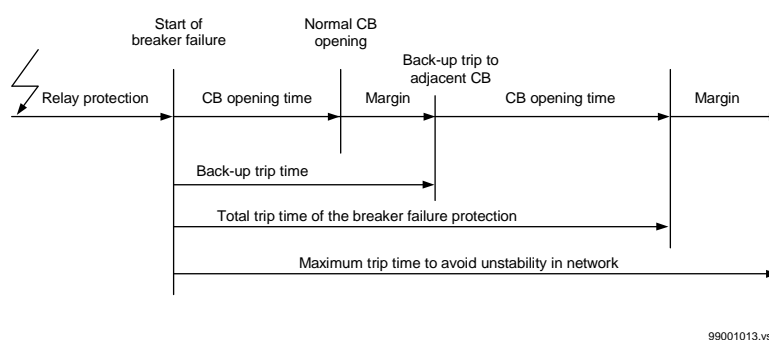

Figure 17: Operating diagram for back-up trip at a breaker-failure situation.

---

## 7 Automatic reclosing function

A well-established method to restore the service of a transmission or sub-transmission line after a transient line fault is to use the automatic reclosing method.

Statistics have shown that the most of the faults are of transient nature and in regions with high lightning intensity only about 5 percentage of the faults are permanent.

When a transmission or sub-transmission line is switched off by operation of a protection and line circuit-breakers, the arc de-ionizes and recovers voltage withstand at a somewhat variable rate. So a certain dead time is needed for the line. But then line service can resume by automatic reclosing of the line circuit-breakers. The length of the dead time should be selected to enable a good probability of fault arc de-ionization and successful reclosing.

Permanent faults can be caused by a broken conductor, collapse of a line tower or when a tree is leaning toward the line. In these cases the line protection trips again at reclosing to clear the fault. The line can only be re-energized after the fault location is traced and the damage is repaired. Figure 18 shows the operation sequence during a permanent fault.

The choice of the automatic reclosing type, such as, one or more reclosing shots, high-speed or delayed depends on the characteristics of the transmission and protection system, together with the utility practice.

The automatic reclosing function can be set to perform 1, 2, 3 or 4 three-phase reclosing shots. The first reclosing can be set to either a high-speed automatic reclosing or an delayed automatic reclosing.

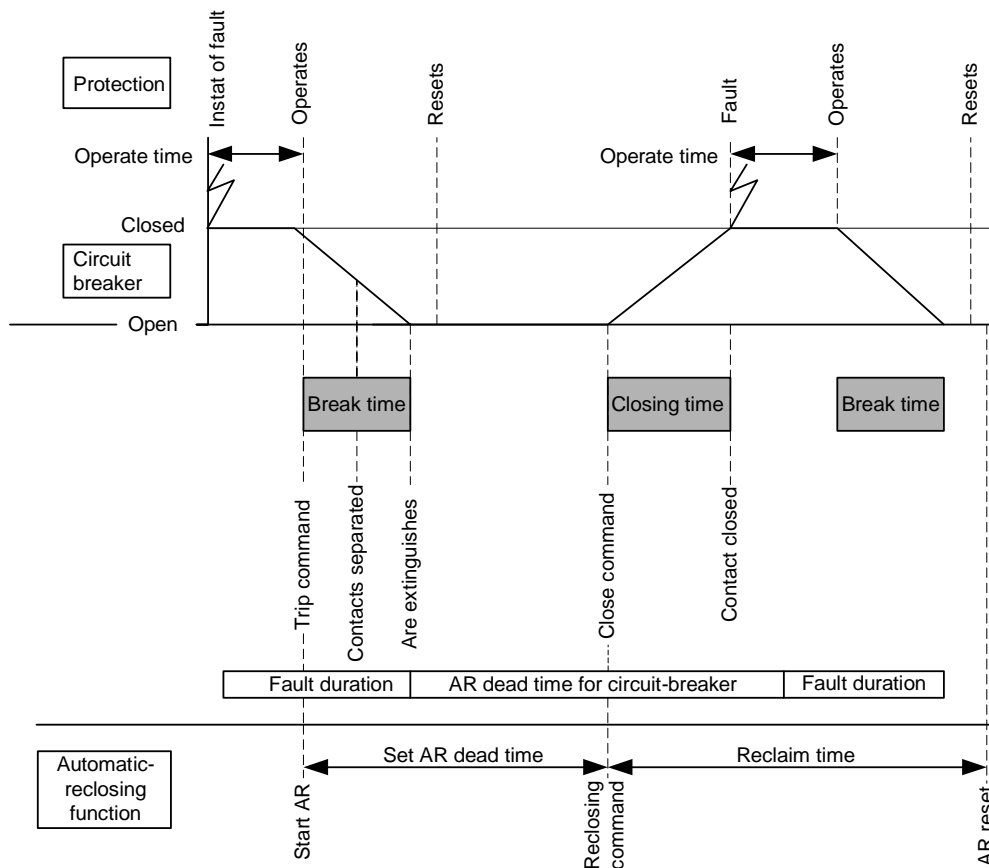

99000146.vsd

Figure 18: Single-shot automatic reclosing at a permanent fault

---

## 8 Binary inputs

As the conditions in the power system change there can be of value to adopt the parameters of the protection functions. To perform such changes the protection must receive information about the changes. This can be done by means of binary input signals to the protection. The information can be given from switching devices, SCADA-systems, other protection, etc. Application examples, when binary inputs are used for the protection, are given below.

- Change of active setting group. A common case is when we have a substation with parallel transformers. During low load periods one transformer is taken out of service while during high load periods the transformers are operated in parallel. To optimize the protection settings a binary input can be used to switch to the alternative setting group.
- Blocking of the high set phase overcurrent protection. This can be done to enable a short fault time at busbar faults.
- Enabling of low set phase overcurrent protection in cases with small fault current in-feed. The binary enabling signal can be collected from other protections in the system.

For RAHL there are possibilities to use binary inputs for several functions. The use of binary inputs can be specified via the local HMI.

# Chapter 4 Requirements

## **About this chapter**

This chapter describes the requirements that must be fulfilled to ensure reliable operation of the protection. The requirements on the main transformers is given.

# 1 Demands on the current transformer

To ensure reliable operation of the protection, the following requirements must be fulfilled.

## 1.1 Overcurrent protection

### 1.1.1 Definitive time delay

To avoid failure to operate it must be assured that the current from the saturated current transformer is large enough for operation of the relay. The rated equivalent limiting secondary e.m.f.,  $E_{al}$  should satisfy the following requirement:

$$E_{al} \geq 2 \cdot I_{set} \cdot [R_{CT} + R_l + Z_r]$$

Where:

$I_{set}$  = the current set value of the relay

$R_{CT}$  = the secondary resistance of the secondary winding of the current transformer

$R_l$  = the resistance of a single secondary wire from the current transformer to the relay

$Z_r$  = the actual burden of the current transformer

It must be observed that we consider only the single length of the secondary wire from the current transformer to the relay. This is valid when we study three-phase overcurrent protection in high impedance grounded systems.

### 1.1.2 Inverse time delay

In the case of overcurrent relays with an inverse time characteristic, it generally applies that saturated current transformers result in longer tripping times. To avoid error in the time delay of the relay the current transformer must not saturate for any possible fault current that can occur. A practical value for the protection to choose is to ensure that a current, 20 times the current setting of the inverse time function, does not give saturation. The rated equivalent limiting secondary e.m.f.,  $E_{al}$  should satisfy the following requirement:

$$E_{al} \geq 20 \cdot I_{set} \cdot [R_{CT} + R_l + Z_r]$$

Where:

$I_{\text{set}}$  = the current set value of the inverse time function

$R_{\text{CT}}$  = the secondary resistance of the secondary winding of the current transformer

$R_l$  = the resistance of a single secondary wire from the current transformer to the relay

$Z_r$  = the actual burden of the current transformer

For logarithmic (IDG) inverse time:

$$E_{\text{al}} \geq 40 \cdot I_{\text{set}} \cdot [R_{\text{CT}} + R_l + Z_r]$$

### 1.1.3

#### Instantaneous function

To avoid failure to operate, of the instantaneous function, it must be assured that the current from the saturated current transformer is large enough for operation of the relay. The function should be assured for fault currents at least 1.5-2.0 times the value set on the relay. The margin depends on the time constant of the network. As a rule, the majority of fault points in distribution networks have low time constants and therefore a margin of 1.5 times the set value should be sufficient. The rated equivalent limiting secondary e.m.f.,  $E_{\text{al}}$  should, in this case, satisfy the following requirement:

$$E_{\text{al}} \geq 1.5 \cdot I_{\text{set}} \cdot [R_{\text{CT}} + R_l + Z_r]$$

Where:

$I_{\text{set}}$  = the current set value of the instantaneous function

$R_{\text{CT}}$  = the secondary resistance of the secondary winding of the current transformer

$R_l$  = the resistance of a single secondary wire from the current transformer to the relay

$Z_r$  = the actual burden of the current transformer

## 1.2

**Accuracy limit factor (ALF) - Calculation example****Table 1: Current transformer data**

<b>Ratio</b>	50-100/5/5 A		
<b>Core 1</b>	5 VA	$F_s = 10$	$R_{CT} = 0.05$
<b>Core 2</b>	30 VA	$K_{SSC} = 10.0$ (ALF)	$R_{CT} = 0.07$
<b>Connected</b>	100/5/5 A		
<b>Relay <math>I_r = 5</math> A</b>	Burden 0.3 VA		

## 1.2.1

**Data for secondary conductors from current transformers to relay**

Cross section = 2.5 mm<sup>2</sup>. Length of copper = 25 m (single length).

Burden, relay = 0.3 / 5<sup>2</sup> = 0.012 ohm.

Burden, secondary conductor =

$$\rho \cdot \frac{L}{a} = 0.0175 \cdot \frac{25}{2.5} = 0.175 \Omega$$

It should be noted that the resistance of the secondary conductors is the main burden of the current transformer circuit.

The rated equivalent limiting secondary e.m.f.,  $E_{al}$  can be calculated as:

$$E_{al} = K_{SSC} \cdot I_n \cdot \left[ R_{CT} + \frac{S_n}{I_n^2} \right]$$

$$E_{al} = 10 \cdot 5 \cdot \left[ 0.07 + \frac{30}{5^2} \right] = 63.5V$$

Where:

$K_{SSC}$  = the rated symmetrical short-circuit current factor

$I_n$  = the rated secondary current of the current transformer

$R_{CT}$  = the secondary resistance of the secondary winding of the current transformer

$S_n$  = the rated burden of the current transformer

If the relay has an instantaneous current setting of 2000 A (primary) corresponding to 100 A (secondary), the demand for  $E_{a1}$  will be:

$$E_{a1} \geq 1.5 \cdot 100 \cdot [0.07 + 0.175 + 0.012] = 38.5 \text{ V}$$

As we can see the requirement on the current transformer is fulfilled.

In solidly grounded systems which are subject to fault currents of high magnitude, the total resistance of the current transformer secondary circuit must be taken into consideration; thus, according to the example,  $L = 2 \cdot 25 \text{ m}$ , if it is required to have a phase relay operate even in the event of ground faults. The secondary e.m.f.  $E_{a1}$  must then be adapted to the maximum earth-fault current, the total resistance ( $2 \cdot 25 \text{ m}$ ) and the maximum short-circuit current and a single length ( $1 \cdot 25 \text{ m}$ ).

If an earth-fault relay, residual current connected to the CT's, is incorporated in the measuring circuit, as shown in figure 19, the earth-fault relay must also be taken into consideration.

## 1.3

### Earth-fault protection

When transformers are residual current connected, certain magnetization losses arise and, in conjunction with the commissioning of an installation, the primary operate value should be checked to ensure that it is correct.

The demand on the current transformers of the sensitive directional earth-fault relay is, that the composite error should be so small, that measuring of the active component of the earth-fault current is not influenced by the capacitive component. This is secured by checking the efficiency factor. In cable networks with risks for intermittent earth-faults, the current transformer has to be dimensioned so that the DC-component of the earth-fault current would not saturate the transformer.

### 1.3.1

#### Efficiency factor

In isolated and high-impedance grounded systems, the earth-fault currents fed to the earth-fault relays are normally small and relays with low operating currents are used. In this case, the efficiency factor of the relay should be checked.

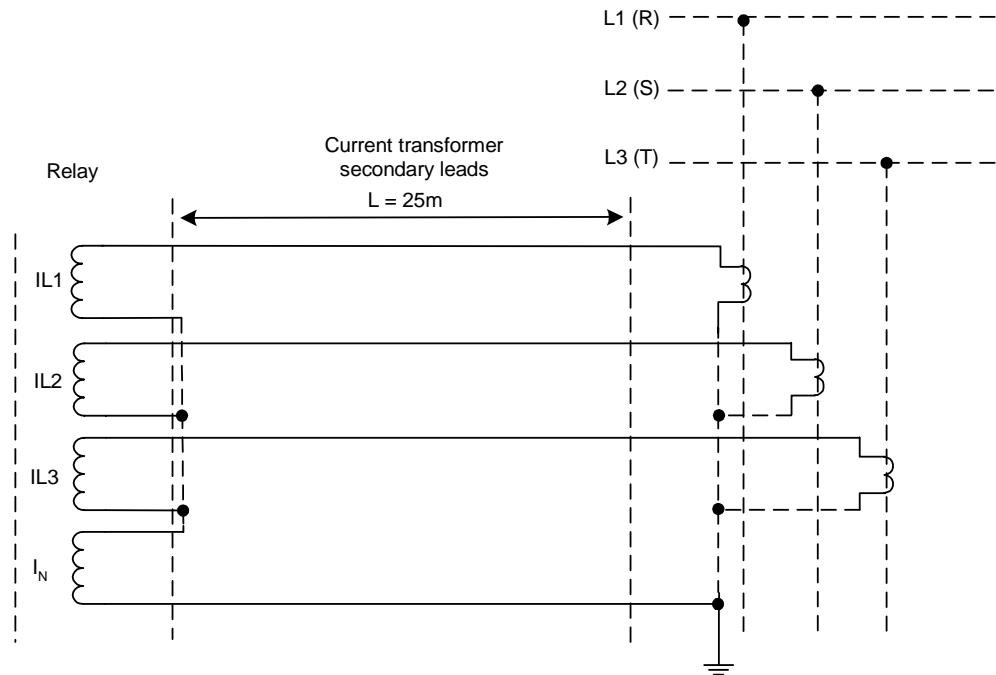

99000143.vsd

Figure 19: Equivalent circuit for current transformer to earth-fault relay.

The efficiency factor is defined as:

$$\eta = \frac{I_r}{I_N} \cdot N_{CT} \cdot 100 \%$$

Where:

$I_r$  = current supplied to the relay

$I_N$  = primary earth-fault current

$N_{CT}$  = current transformer ratio

The efficiency factor can be calculated from the formula:

---

$$\eta = 100 \cdot \frac{Z_m}{Z_m + Z_2 + C \cdot (Z_L + Z_r)} \%$$

Where:

$Z_m$  = magnetizing impedance of the current transformer(s)

$Z_2$  = resistance of the current transformer secondary winding plus resistance of wires up to the interconnection (per phase)

$Z_L$  = resistance of wires up to the earth-fault relay (loop resistance)

$Z_r$  = impedance (resistance) of the measuring circuit of the relay

$C$  = 1 for core balanced CTs

$C$  = 3 for residual connected current transformers

It should be observed that the magnetizing impedance varies with the voltage. The impedance  $Z_m$  at the secondary voltage which gives relay operation is inserted in the formula. If the angle of the impedance  $Z_m$  is not known, the value 45 degrees (lagging) can be assumed.

The requirement on  $\eta$  is:

$\eta > 80\%$  for earth-fault relays



# **Chapter 5 Functional description**

## **About this chapter**

This chapter describes how the relay and each protection function is working. The theories behind the measurement principles and how the function operates is given. By reading this chapter the reader will gain knowledge about how the relay works.

# 1 Compact current relay RXHL 411

## 1.1 Theory of operation

The compact current relay RXHL 411 constitutes the measuring unit of the protection assembly RAHL 411.

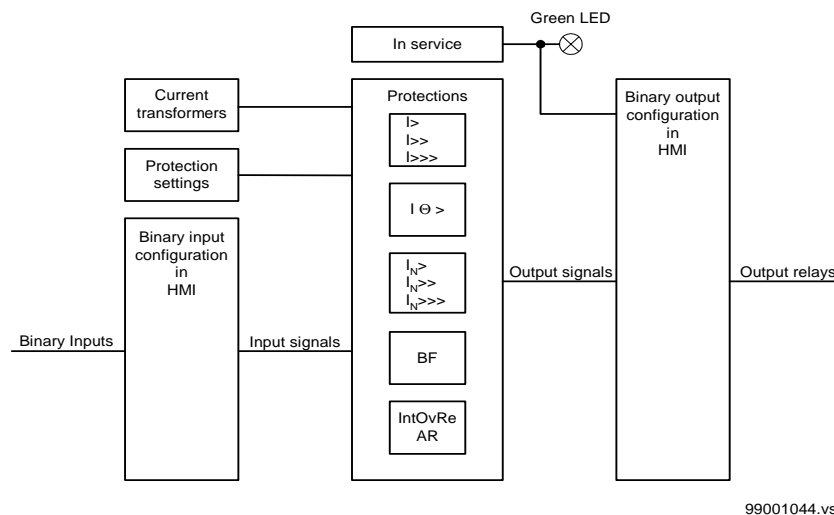

Figure 20: Simplified logic diagram for the compact current relay RXHL 411.

### 1.1.1 Measuring principle

The compact current relay RXHL 411 has four measuring inputs which are galvanically separated with current transformers. The voltage from each transformers shunt resistor is applied to zero detectors for frequency estimation and to the measuring circuitry through bandpass filters with a centre frequency equal to 55 Hz.

The relay sampling the input signals with a sample rate of 18 samples per duty cycle. The relay tracking the input signals to increase the accuracy of the measured values. The tracking function is enabled within the following ranges: 40-60 Hz when rated frequency is set to 50 Hz or 50-70 Hz when rated frequency is set to 60 Hz. Figure 21 shows which values the relay calculates from the input signals.

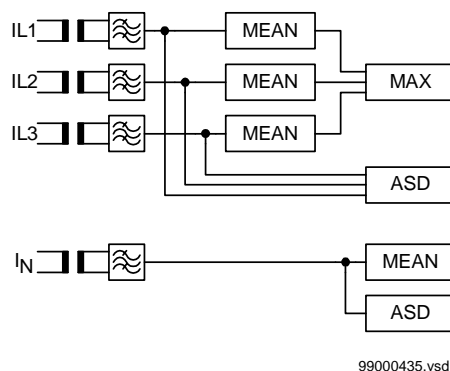

Figure 21: Calculated values from the input signals

Calculated values	Used by protection
MAX value of the MEAN phase currents, IL1, IL2 and IL3	<ul style="list-style-type: none"> <li>• Overcurrent protection</li> <li>• Thermal overload protection</li> <li>• Breaker failure protection</li> </ul>
MEAN value of neutral current	<ul style="list-style-type: none"> <li>• Earth-fault protection</li> <li>• Breaker failure protection</li> </ul>
ASD signal on phase and neutral current	<ul style="list-style-type: none"> <li>• Breaker failure protection</li> </ul>

The intention of the Adaptive Signal Detection (ASD) concept is to achieve independence from the absolute filtering requirement, when dealing with extremely high fault currents in combination with low pre-set values. This is obtained by creating a new stabilizing signal to compare the current with.

When the current exceeds the previously stabilized sample, it adapts the value of the current and when it does not, it decays. This adaptive behavior makes it possible to rapidly and securely detect a breaker-failure situation.

## 1.2

### Setting parameters

Table 2: Rated system frequency

Parameter	Range	Unit	Default	Let you...
Freq	50/60	Hz	50 Hz	Select the rated frequency.

**Table 3: Main CT Ratio**

Parameter	Range	Unit	Default	Let you...
Primary	1.00 - 999	A	1.00 A	Select the primary rated value of the CT's
	1.00 - 100	kA	-	
Secondary	0.40 - 10.0	A	1.00 A	Select the secondary rated value of the CT's

## 2 Overcurrent protection

### 2.1 Theory of operation

The overcurrent protection functions compares the calculated MAX value with the pre-set current values for each stage I>, I>> and I>>>. When the measured current exceeds or is equal to the pre-set value of the stage, start function seals-in the phase(s) which cause the start and activates the start signal. A simplified logic diagram for the overcurrent protection is shown in figure 22.

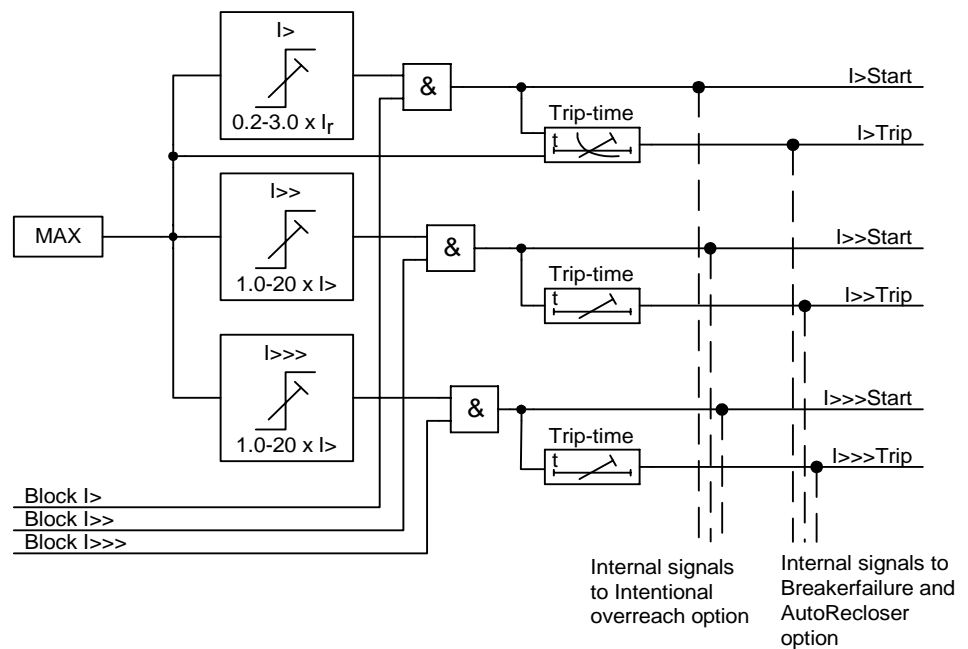

99000441.vsd

Figure 22: Simplified logic diagram for the overcurrent protections.

The low set stage I> is prevented with a reset time logic function for detection of intermittent faults. When the measured current exceeds the pre-set value the trip counter starts to count-up, if the current then decreases below the pre-set value the trip counter counts-down. When the trip function operates the trip counter will automatically reset.

## 2.2

**Binary input and output signals****Table 4: Input signals, overcurrent protection**

Signal	Default	Description
I> Block/Enable	-	Active signal blocks or enables the low set overcurrent stage I>
I>> Block/Enable	-	Active signal blocks or enables the medium set overcurrent stage I>>
I>>> Block/Enable	-	Active signal blocks or enables the high set overcurrent stage I>>>

**Table 5: Output signals, overcurrent protection**

Signal	Default	Description
I>St	Relay 1	Start signal from low set overcurrent stage I>
I>Tr	Relay 2	Trip signal from low set overcurrent stage I>
I>>St	Relay 1	Start signal from medium set overcurrent stage I>>
I>>Tr	Relay 2	Trip signal from medium set overcurrent stage I>>
I>>>St	Relay 1	Start signal from high set overcurrent stage I>>>
I>>>Tr	Relay 2	Trip signal from high set overcurrent stage I>>>

**Table 6: Internal output signals, overcurrent protection**

Signal	Description
I>St	Start signal to other internal functions from low set overcurrent stage I>
I>Tr	Trip signal to other internal functions from low set overcurrent stage I>
I>>St	Start signal to other internal functions from medium set overcurrent stage I>>

Signal	Description
I>>Tr	Trip signal to other internal functions from medium set overcurrent stage I>>
I>>>St	Start signal to other internal functions from high set overcurrent stage I>>>
I>>>Tr	Trip signal to other internal functions from high set overcurrent stage I>>>

## 2.3

## Setting parameters

Table 7: Setting parameters for overcurrent protection

Parameter	Range	Unit	Default	Let you...
I>	On - Off	-	On	Select low set stage I> to be active or not.
I>	0.2 - 3.0 x I <sub>r</sub>	A	0.2 x I <sub>r</sub>	Set operate level.
Char	NI, VI, EI, LI, RI, Def	-	Def	Select time characteristic, inverse or definite time.
KValue	0.05 - 1.10	-	-	Set time multiplier for inverse time function.
MinTime	0.00 - 2.00	s	-	Set minimum definite time delay for inverse time characteristic.
Time	0.00 - 20.0	s	0.00 s	Set definite time delay.
ResetT	0.00 - 500	s	0.00 s	Set linear reset time on I>.
I>>	On - Off	-	On	Select medium set stage I>> to be active or not.
I>>	1.0 - 20 x I>	A	1.0 x I>	Set operate level.
Time	0.00 - 20.0	s	0.00 s	Set definite time delay.
I>>>	On - Off	-	On	Select high set stage I>>> to be active or not.
I>>>	1.0 - 20 x I>	A	1.0 x I>	Set operate level.
Time	0.00 - 20.0	s	0.00 s	Set definite time delay.

## 3 Thermal overload protection

### 3.1 Theory of operation

The thermal overload protection uses the calculated MAX value in the thermal formula. The accumulated thermal content increases or decreases with  $(I^2 - \Theta) / (\tau \times 60)$  per second. The thermal overload protection compare the accumulated thermal content  $\Theta$  with the pre-set thermal values for  $\Theta > A1$  and  $\Theta > Tr$ .

The thermal operating characteristic follows the IEC formula 60255-8:

$$t = \tau \cdot \ln \frac{I^2 - I_p^2}{I^2 - I_b^2}$$

Where:

$t$  = operate time

$\tau$  = set thermal time constant

$I$  = overload current

$I_p$  = preload current

$I_b$  = set operate current

A simplified logic diagram for the thermal overload protection is shown in figure 23.

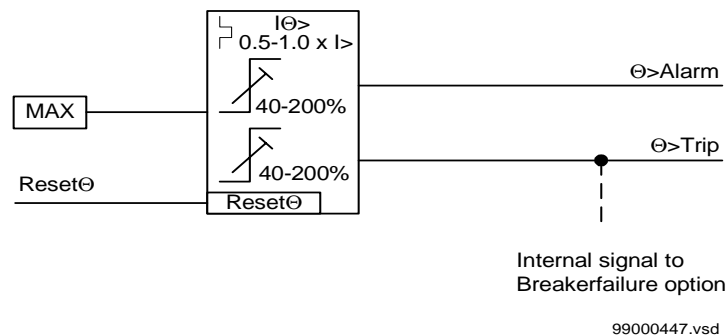

Figure 23: Simplified logic diagram for the thermal overload protection

## 3.2

## Input and output signals

Table 8: Input signals, thermal overload protection

Signal	Default	Description
Reset $\Theta$	-	Active signal resets the thermal heat content

Table 9: Output signals, thermal overload protection

Signal	Default	Description
$\Theta$ >Al	Relay 3	Alarm signal from thermal overload stage
$\Theta$ >Tr	Relay 2	Trip signal from thermal overload stage

Table 10: Internal output signals, thermal overload protection

Signal	Description
$\Theta$ >Tr	Trip signal to other internal functions from thermal overload stage

## 3.3

## Setting parameters

Table 11: Setting parameters for thermal overload protection

Parameter	Range	Unit	Default	Let you...
I $\Theta$ >	On - Off	-	On	Select the thermal function to be active or not.
I $\Theta$ >	0.5 - 1.0 x I>	A	0.5 x I>	Set operate level.
Tau	0 - 120	min	0 min	Set thermal time constant
$\Theta$ >Alarm	40 - 200	%	95 %	Set alarm level content.
$\Theta$ >Trip	40 - 200	%	100 %	Set trip level content.
StUp $\Theta$	0 - 99	%	80 %	Set thermal start-up content.

## 4 Earth-fault protection

### 4.1 Theory of operation

The earth-fault protection compare the calculated MEAN value with the pre-set current values for  $I_{N>}$ ,  $I_{N>>}$  and  $I_{N>>>}$ . When the measured current exceeds or is equal to the pre-set value of the stage, start function activates the start signal. A simplified logic diagram for the earth-fault protection is shown in figure 24.

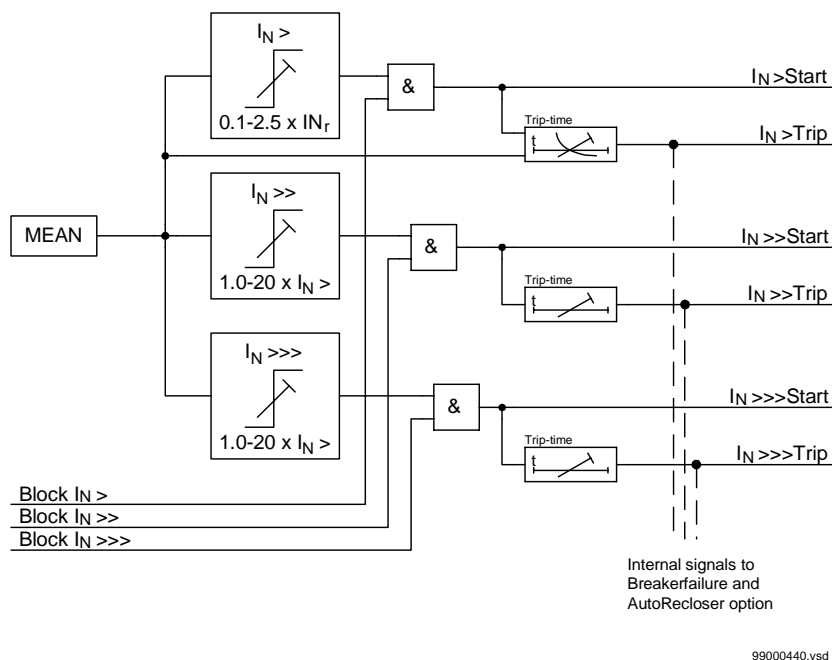

Figure 24: Simplified logic diagram for the earth-fault protection.

The low set stage  $I_{N>}$  is prevented with a reset time logic function for detection of intermittent faults. When the measured current exceeds the pre-set value the trip counter starts to count-up, if the current then decreases below the pre-set value the trip counter counts-down. When the trip function operates the trip counter will automatically reset.

## 4.2

## Input and output signals

Table 12: Input signals, earth-fault protection

Signal	Default	Description
$I_N>$ Block/Enable	-	Active signal blocks or enables the low set earth-fault stage $I_N>$
$I_N>>$ Block/Enable	-	Active signal blocks or enables the medium set earth-fault stage $I_N>>$
$I_N>>>$ Block/Enable	-	Active signal blocks or enables the high set earth-fault stage $I_N>>>$

Table 13: Output signals, earth-fault protection

Signal	Default	Description
$I_N>St$	Relay 1	Start signal from low set earth-fault stage $I_N>$
$I_N>Tr$	Relay 2	Trip signal from low set earth-fault stage $I_N>$
$I_N>>St$	Relay 1	Start signal from medium set earth-fault stage $I_N>>$
$I_N>>Tr$	Relay 2	Trip signal from medium set earth-fault stage $I_N>>$
$I_N>>>St$	Relay 1	Start signal from high set earth-fault stage $I_N>>>$
$I_N>>>Tr$	Relay 2	Trip signal from high set earth-fault stage $I_N>>>$

Table 14: Internal output signals, earth-fault protection

Signal	Description
$I_N>Tr$	Trip signal to other internal functions from low set earth-fault stage $I_N>$
$I_N>>Tr$	Trip signal to other internal functions from medium set earth-fault stage $I_N>>$
$I_N>>>Tr$	Trip signal to other internal functions from high set earth-fault stage $I_N>>>$

## 4.3

## Setting parameters

Table 15: Setting parameters for earth-fault protection

Parameter	Range	Unit	Default	Let you...
$I_{N>}$	On - Off	-	On	Select low set stage $I_{N>}$ to be active or not.
$I_{N>}$	$0.1 - 2.5 \times I_{N_r}$	A	$0.1 \times I_{N_r}$	Set operate level.
Char	NI, VI, EI, LI, RI, Log, Def	-	Def	Select time characteristic, inverse, logarithmic or definite time.
KValue	0.05 - 1.10	-	-	Set time multiplier for inverse time function.
	1.00 - 4.00	-	-	Set operate constant for logarithmic time function.
MinTime	0.00 - 2.00	s	-	Set minimum definite time delay for inverse time function.
	1.00 - 2.00	s	-	Set minimum definite time delay for logarithmic time function.
Time	0.00 - 20.0	s	0.00 s	Set definite time delay.
ResetT	0.00 - 500	s	0.00 s	Set linear reset time on $I_{N>}$ .
$I_{N>>}$	On - Off	-	On	Select medium set stage $I_{N>>}$ to be active or not.
$I_{N>>}$	$1.0 - 20 \times I_{N>}$	A	$1.0 \times I_{N>}$	Set operate level.
Time	0.00 - 20.0	s	0.00 s	Set definite time delay.
$I_{N>>>}$	On - Off	-	On	Select high set stage $I_{N>>>}$ to be active or not.
$I_{N>>>}$	$1.0 - 20 \times I_{N>}$	A	$1.0 \times I_{N>}$	Set operate level.
Time	0.00 - 20.0	s	0.00 s	Set definite time delay.

---

## 5 Breaker failure protection

### 5.1 Theory of operation

The breaker-failure protection in the relay co-operates first of all with internal trip signals from the protections and the line circuit-breaker. It can also be activated by external functions via the binary input “BFExtSt”.

The breaker-failure protection activates by internal trip signals or via the binary-input signal “BFExtSt”. If the ASD signal or the MEAN value signal change state to false before the pre-set back-up trip time delay has expired the function instantaneously resets. If the pre-set back-up trip time delay expires and the two signals state are true the back-up trip signal operates.

The input current must exceed the pre-set activation current level for activation of the breaker-failure function. The breaker-failure function compares the MEAN value with 90 percent of the pre-set activation current level and if it is equal or higher the signal is true.

The breaker-failure protection has separated measuring elements for phase and earth-fault currents. The output signal re-trip operates only when the breaker-failure protection is started via the binary-input. A simplified logic diagram for the breaker-failure protection is shown in figure 25.

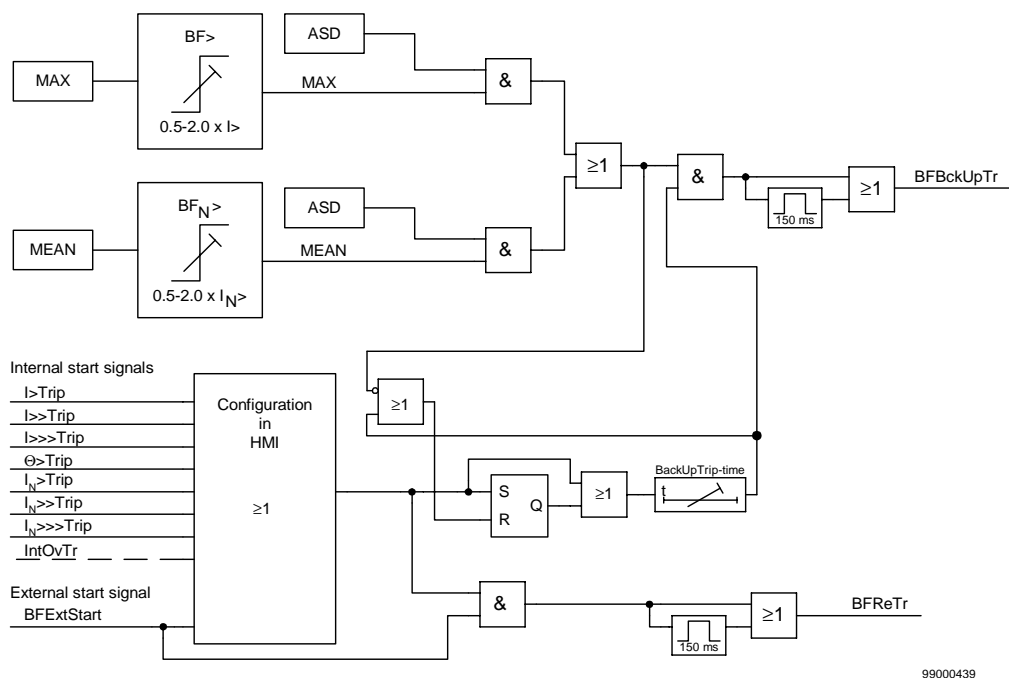

Figure 25: Simplified logic diagram for the breaker-failure protection.

**5.1.1 During normal operation of the line circuit-breaker**

During normal operation of the line circuit-breaker, the stabilizing signal exceeds the input current signal which results in a reset of the breaker failure function before the back-up trip timer has expired.

**5.1.2 During a breaker-failure situation**

During a breaker-failure situation, the input current exceeds the stabilizing signal which results in a trip of the breaker-failure function after the back-up trip timer has expired.

**5.2 Input and output signals**

Table 16: Input signals, breaker failure protection

Signal	Default	Description
BFExtStart	-	Active external signal starts the breaker failure protection

**Table 17: Output signals, breaker failure protection**

Signal	Default	Description
BFR <sub>e</sub> Tr	Relay 2	Re-trip signal when external input is activated
BFB <sub>ckUp</sub> Tr	Relay 4	Back-up trip signal to adjacent circuit-breakers

### 5.3

### Setting parameters

**Table 18: Setting parameters for breaker failure protection**

Parameter	Range	Unit	Default	Let you...
BrkFail	On - Off	-	On	Select breaker-failure function to be active or not.
BF <sub>&gt;</sub>	50 - 200	%	100 %	Set activation level in percentage of the overcurrent function I <sub>&gt;</sub> .
BF <sub>N&gt;</sub>	50 - 200	%	100 %	Set activation level in percentage of the earth-fault function I <sub>N&gt;</sub> .
Time	0.10 - 1.00	s	0.10 s	Set definite time delay for back-up trip.
I <sub>&gt;</sub> Tr	On - Off	-	On	Select active or not for I <sub>&gt;</sub> trip signal.
I <sub>&gt;&gt;</sub> Tr	On - Off	-	On	Select active or not for I <sub>&gt;&gt;</sub> trip signal.
I <sub>&gt;&gt;&gt;</sub> Tr	On - Off	-	On	Select active or not for I <sub>&gt;&gt;&gt;</sub> trip signal.
Θ <sub>&gt;</sub> Tr	On - Off	-	On	Select active or not for thermal trip signal.
I <sub>N&gt;</sub> Tr	On - Off	-	On	Select active or not for I <sub>N&gt;</sub> trip signal.
I <sub>N&gt;&gt;</sub> Tr	On - Off	-	On	Select active or not for I <sub>N&gt;&gt;</sub> trip signal.
I <sub>N&gt;&gt;&gt;</sub> Tr	On - Off	-	On	Select active or not for I <sub>N&gt;&gt;&gt;</sub> trip signal.
ExtStart	On - Off	-	On	Select active or not for external start signal.
IntOvTr	On - Off	-	On	Select active or not for intentional over-reach trip signal.

## 6 Intentional overreach trip function

### 6.1 Theory of operation

The intentional overreach trip function in the relay co-operates first of all with the automatic reclosing function and internal start signals from overcurrent protections. The intentional overreach trip function is based on internal logic and a timer.

The function is only enabled for operation when the automatic reclosing function is in “ARReady” state (automatic recloser ready for first shot).

A simplified logic diagram for the intentional overreach trip function is shown in figure 26.

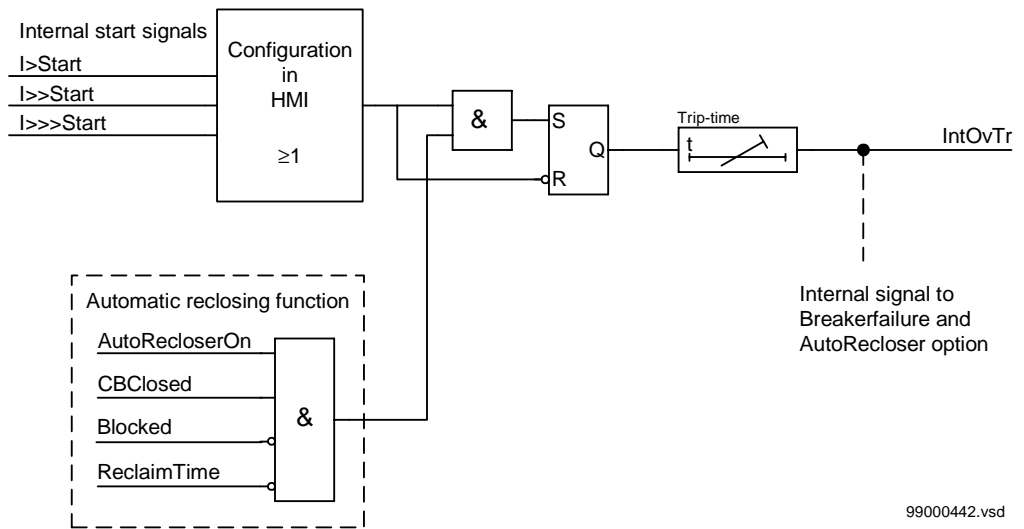

99000442.vsd

Figure 26: Simplified logic diagram for the intentional overreach trip function.

### 6.2 Input and output signals

Table 19: Output signal, intentional overreach trip function

Signal	Default	Description
IntOvTr	-	Trip signal for intentional overreach trip function

**Table 20: Internal output signal, intentional overreach trip function**

Signal	Description
IntOvTr	Trip signal to other internal functions from intentional overreach trip function

**6.3****Setting parameters****Table 21: Setting parameters for intentional overreach trip function**

Parameter	Range	Unit	Default	Let you...
IntOvRe	On - Off	-	Off	Select intentional overreach function to be active or not.
Time	0.00 - 10.0	s	0.00 s	Set definite time delay for fuse selectivity.
I>St	On - Off	-	Off	Select active or not for I> start signal.
I>>St	On - Off	-	Off	Select active or not for I>> start signal.
I>>>St	On - Off	-	Off	Select active or not for I>>> start signal.

## 7 Automatic reclosing function

### 7.1 Theory of operation

The automatic reclosing function in the relay co-operates first of all with internal trip signals from the protections and the line circuit-breaker. It can also be influenced by external functions via the binary input, manual control “ARExtOn”. The automatic reclosing function can be set to perform 1, 2, 3 or 4 three-phase reclosing shots. The dead-time between the shots is set by separate time delays. The automatic reclosing can be set to give either a high-speed automatic reclosing or a delayed automatic reclosing. The automatic reclosing function is based up on internal logic, binary input signals and timers. Reclosing counter data, such as the reclosing shots and also unsuccessful reclosings related to source, can be viewed through the local HMI. Figure 27 and 28 show a simplified logic diagram for the automatic reclosing function.

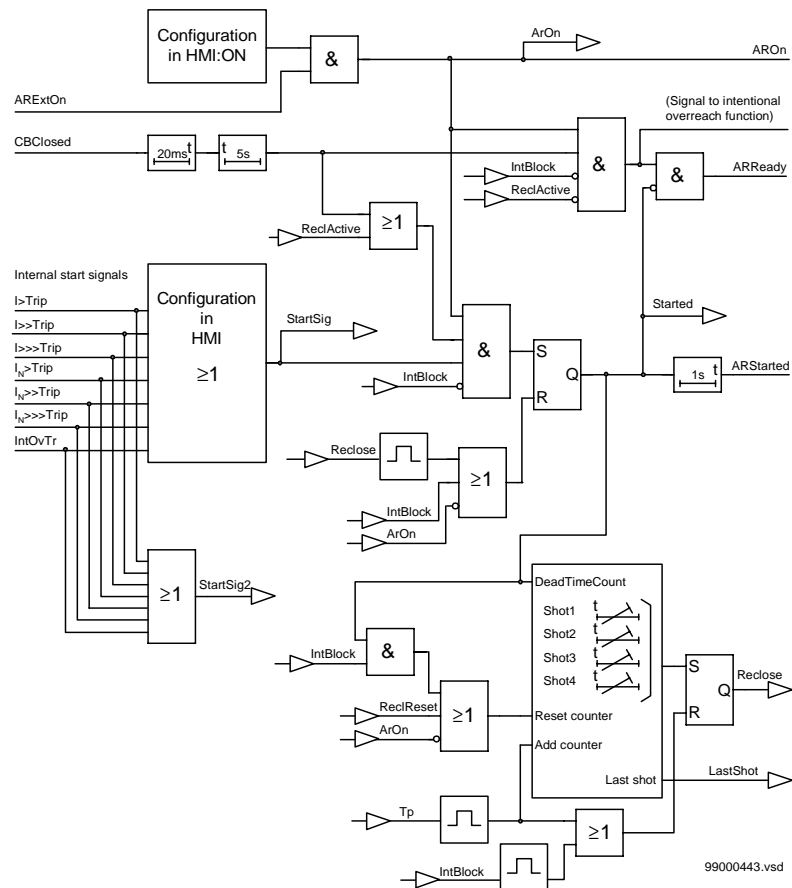

Figure 27: Simplified logic diagram for the automatic reclosing function, part 1.



---

The line circuit-breaker must have its operating gear charged and ready for a Close-Open (CO) or an Open-Close-Open (OCO) cycle, to allow a start of an automatic reclosing cycle. If the binary input “CBReady” is low (deactivated) at the start, there is a little chance that it will be high (active) by the end of the dead-time.

The output signal “ARUnsucce” is activated if a new trip occurs after the selected number of reclosing shots. The output signal will be reset after the reclaim time has expired.

### **Reclosing program**

The three-phase reclosing program can be performed with up to four reclosing shots, selectable in the local HMI.

In this example, the automatic reclosing function is assumed to be On and Ready. The circuit-breaker is closed and the operation gear ready, maneuver spring charged etc.

At operation of the protection a start signal is received and sealed-in. The output signal “ARReady” is reset (ready for a new reclosing cycle).

Immediately after the start signal is received by the reclosing and the protection has tripped of the line circuit-breaker, the input “CBClosed” gets low (possibly also “CBReady” at type OCO). The dead-time for shot 1 counts.

At the end of the set dead-time for shot 1, a reclosing signal is activated and distributed to the output logic module for further checks and to give a closing command to the line circuit-breaker.

### **Reclosing checks and reclaim timer**

A reclosing signal is received after set dead-time for shot 1 from the reclosing program module. Binary input “CBReady” is checked and must be high (active) to allow a reclosing, if it does not the reclosing is interrupted and blocked.

When the reclosing command is given from the reclosing program module the reclaim-timer is started.

The reclaim-timer defines a period from the issue of a reclosing command, after which the reclosing function is reset. Should a new trip occur within this time, it is treated as a continuation of the first fault.

### **Pulsing of CB closing command**

The line circuit-breaker reclosing command, “ARCloseCB”, is made as a pulse with a duration of 200 ms. For line circuit-breakers without an anti-pumping function, the reclosing pulse will be reset immediately when a new trip pulse from any of the internal protections are received (also unmarked protection signal included). Minimum length of the reclosing pulse is always 50 ms.

At the issue of a reclosing command, the associated reclosing counter counts-up.

#### Transient fault

After the reclosing command, the reclaim-timer starts to count-up to the set time. If no new tripping occurs within this time, the automatic reclosing function will be reset. The line circuit-breaker remains closed and the operating gear is ready (maneuver spring is recharged). Binary inputs “CBClosed” and “CBReady” gets high (active).

After the set reclaim time has been reached, the automatic reclosing function state goes into the “ARReady” state.

#### Unsuccessful signal

The output signal “ARUnsucce” appears when a new trip is received after the last reclosing shot has been made. The output signal “ARUnsucce” resets when the reclaim time has expired.

#### Permanent fault

In a two shot reclosing program, two reclosing operations are made. Should the fault be permanent and a new trip is received after the second reclosing, the output signal “ARUnsucce” (reclosing unsuccessful) is activated and the automatic reclosing function will be blocked during the reclaim time. When the reclaim time has expired, the automatic reclosing function will be reset, but the line circuit-breaker remains open. Binary inputs “CBClosed” low (deactivated) and “CBReady” high (active), which means that the automatic reclosing function is not ready for a new reclosing function.

## 7.2

### Input and output signals

Table 22: Input signals, automatic reclosing function

Signal	Default	Description
ARExtOn	-	Active signal enables the automatic reclosing function
CBClosed <sup>a)</sup>	-	Active signal when circuit-breaker is closed
CBReady <sup>a)</sup>	-	Active signal when circuit-breaker is ready
ARBlock	-	Active signal blocks the automatic reclosing function

a) Unconfigured signal reads as TRUE by the function.

**Table 23: Output signals, automatic reclosing function**

Signal	Default	Description
AROn	-	Automatic reclosing function is on
ARReady	-	Automatic reclosing function is ready
ARStarted	-	Automatic reclosing program is started
ARCloseCB	-	Automatic reclosing pulse to circuit-breaker
ARUnsucce	-	Unsuccessful reclosing

## 7.3

**Setting parameters****Table 24: Setting parameters for automatic reclosing function**

Parameter	Range	Unit	Default	Let you...
AutoRec	On - Off	-	Off	Select the automatic reclosing function to be active or not.
ReclT	10.0 - 300	s	10.0 s	Set reclaim time for the reclosing program.
Shot1	0.20 - 60.0	s	0.20 s	Set dead time before first reclosing pulse.
Shot2	1.00 - 300, Off	s	Off	Select off or dead time before second reclosing pulse.
Shot3	1.00 - 300, Off	s	Off	Select off or dead time before third reclosing pulse.
Shot4	1.00 - 300, Off	s	Off	Select off or dead time before fourth reclosing pulse.
I>Tr	On - Off	-	Off	Select active or not for I> trip signal.
I>>Tr	On - Off	-	Off	Select active or not for I>> trip signal.
I>>>Tr	On - Off	-	Off	Select active or not for I>>> trip signal.
I <sub>N</sub> >Tr	On - Off	-	Off	Select active or not for I <sub>N</sub> > trip signal.
I <sub>N</sub> >>Tr	On - Off	-	Off	Select active or not for I <sub>N</sub> >> trip signal.
I <sub>N</sub> >>>Tr	On - Off	-	Off	Select active or not for I <sub>N</sub> >>> trip signal.
IntOvTr	On - Off	-	Off	Select active or not for intentional over-reach trip signal.

## 8 Indications

### 8.1 Indications menu

The following indications are presented when the indications menu is entered. Stored primary trip values are always from the last disturbance and will also be presented through this menu.

Indication	Start	Trip	Function description
I>	<input type="checkbox"/> 1/2	<input type="checkbox"/> 1/2	Status and active group for overcurrent, low set stage.
	L123		Phase indication which caused the start on I>
I>>	<input type="checkbox"/> 1/2	<input type="checkbox"/> 1/2	Status and active group for overcurrent, medium set stage.
	L123		Phase indication which caused the start on I>>
I>>>	<input type="checkbox"/> 1/2	<input type="checkbox"/> 1/2	Status and active group for overcurrent, high set stage.
	L123		Phase indication which caused the start on I>>>
Θ>	<input type="checkbox"/> 1/2	<input type="checkbox"/> 1/2	Status and active group for thermal overload.
I <sub>N</sub> >	<input type="checkbox"/> 1/2	<input type="checkbox"/> 1/2	Status and active group for earth-fault, low set stage.
I <sub>N</sub> >>	<input type="checkbox"/> 1/2	<input type="checkbox"/> 1/2	Status and active group for earth-fault, medium set stage.
I <sub>N</sub> >>>	<input type="checkbox"/> 1/2	<input type="checkbox"/> 1/2	Status and active group for earth-fault, high set stage.
ReTrip		<input type="checkbox"/>	Status for breaker failure, re-trip.
BckUpTr		<input type="checkbox"/>	Status for breaker failure, back-up trip.
IntOvTr		<input type="checkbox"/>	Status for intentional overreach trip.

Number 1 or 2 (start and trip) above indicates which setting group that was active during the disturbance. All start functions are connected to the yellow LED and all trip functions are connected to the red LED. The appearance of the boxes in the local HMI describes the status of the function.

Filled (black)	Latest recorded event.
Grayed	Previous recorded event.
Blank	No recorded event (since last clearing).

---

Recorded trip values	Provides information about
IL1	The recorded phase-1 current
IL2	The recorded phase-2 current
IL3	The recorded phase-3 current
$I_N$	The recorded neutral current

## 8.2

### Input and output signals

Table 25: Input signal, indications

Signal	Default	Description
ResetLED	-	Active signal resets LED's, clears recorded disturbances and trip values

## 9 Active setting group

### 9.1 Theory of operation

During setting and configuration of the protection the user selects which setting parameter group to be active. The relay switches to the alternative setting parameter group when the binary input function “ChActGrp” is activated. The binary output signal “Group2Act” indicates that group 2 is active.

### 9.2 Input and output signals

**Table 26: Input signal, active setting group**

Signal	Default	Description
ChActGrp	-	Active signal changes active setting group

**Table 27: Output signal, active setting group**

Signal	Default	Description
Group2Act	-	Active signal when Group2 is selected

### 9.3 Setting parameters

**Table 28: Setting parameters, active setting group**

Parameter	Range	Unit	Default	Let you...
Active group	Group1, Group2	-	Group1	Select active group 1 or group 2 <sup>a)</sup>

a) Default settings for setting group 2 are the same as for group 1.

## 10 Self-supervision

### 10.1 Theory of operation

All micro-processors in the measuring relay executes a self test sequence during start-up. The green “In service” LED will light-up when the relay is ready for operation. In a case of an internal fault, the LED’s will start flashing or an error message will be presented in the local HMI-display. The tables below are provided with more fault information. The program in the micro-processors is executed in a fixed loop.

The loop is supervised by an internal watch dog which initiates a program restart if the program malfunctions.

Both hardware and software supervision is included and it is also possible to indicate eventual faults through a binary output error signal.

**Table 29: Self-supervision indications in RXHL**

Indication	Test sequence	Description
Green, yellow and red LED’s are flashing.	Internal watchdog	Internal watchdog has timed out.
Green and yellow LED’s are flashing.	ROM	Checksum error.
Green and red LED’s are flashing.	RAM	Error in memory cells.
“E ain” is presented in the HMI-display	Internal communication error	Analog printed circuit card is not responding.
“E bin” is presented in the HMI-display		Binary I/O (option) printed circuit card is not responding.

# Chapter 6 Design description

## **About this chapter**

This chapter describes how the protection assembly and the measuring relay is designed. The different parts and the different variants that make up the protection assemblies are described.

---

# 1 Protection assembly

## 1.1 Compact current protection assembly RAHL

The protection assemblies are of protective class I equipment in which protection against electric shock does not rely on basic insulation only, but which includes additional safety precautions in such a way that accessible conductive parts are connected to protective earth. The protections are based on the compact current relay RXHL. Test device RTXP 8, RTXP 18 and DC/DC-converter RXTUG 22H can also be included for specific application requirements. Test device, RTXP 8 and RTXP 18 are tools for relay testing. DC/DC-converter RXTUG 22H can be used either separately for a single protection or to feed other protections of the same relay family. With RXTUG 22H all requirements concerning emission and immunity disturbances with this protection assembly will be met.

The basic version of the measuring relay has 5 binary outputs and 2 binary inputs. The binary I/O option includes 4 additional inputs and 4 additional outputs. Protections are normally available with output logic with heavy duty contacts, relay RXME 18 with indicating flag, and can upon request be completed with an output logic of free choice. Output relays are connected to separate auxiliary voltage. The interface voltage for enable or block impulses can be connected to either 48-60 V DC or 110-220 V DC by connecting the voltage circuit to separate terminals. At delivery all relays are connected for 110-220 V DC.

All the protections in the COMBIFLEX<sup>®</sup> modular system are mounted on apparatus bars. The connections to the protections are done by COMBIFLEX<sup>®</sup> socket equipped leads. All internal connections are made and the protection assembly is tested before delivery from factory. The type of modules and their physical position and the modular size of the protection are shown in the diagrams of the respective protection. Figure 29 shows an example of a protection assembly.

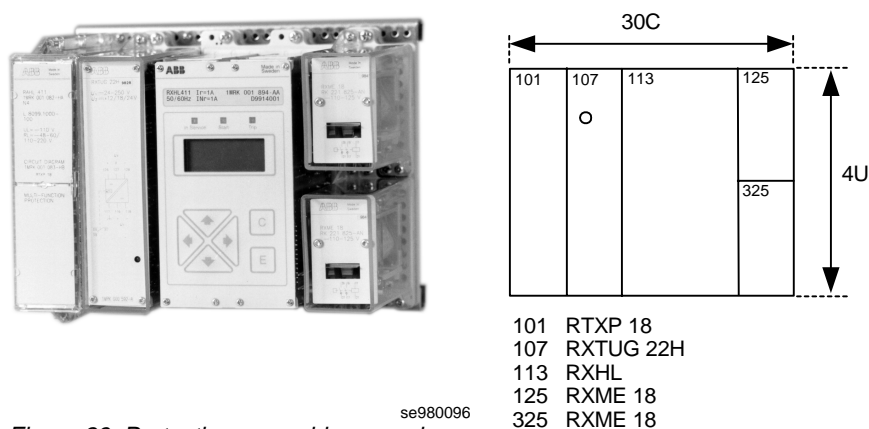

se980096  
Figure 29: Protection assembly example

The height and width of the protection assembly are given in the circuit diagram with height (U) and width (C) modules, where  $U = 44.45$  mm and  $C = 7$  mm. The depth of the protection assembly, including space for the connection wires, is approximately 200 mm.

## 1.2

### Test switch RTXP 18

The test switch RTXP 18 is a part of the COMBITEST testing system described in the Technical overview brochure No. 1MRK 512 001-BEN. A complete secondary testing of the protection can be performed by using a test-plug handle RTXH 18, connected to a test set. When the test-plug handle is inserted into the test switch, preparations for testing are automatically carried out in a proper sequence, that is blocking of tripping circuits, short-circuiting of current circuits, opening of voltage circuits. This makes the protection available for secondary testing. Test switch RTXP 18 has the modular dimensions 4U 6C.

All input currents can be measured by a test plug RTXME connected to an ammeter. The tripping circuits can be blocked by a trip-block plug RTXBL and the protection can be totally blocked by a block-plug handle RTXFB 18.

### 1.3 DC/DC-converter RXTUG 22H

The DC/DC-converter RXTUG 22H converts the station battery voltage to an alternating voltage which is then transformed, rectified, smoothed and in this application regulated to +/-24 V DC. The auxiliary voltage is in that way adapted to the measuring unit. The input and output voltages are galvanically separated, which contributes to damping of possible transients in the auxiliary voltage supply to the measuring relay. The converter has a built-in signal relay and a green LED for supervision of the output voltage.

RXTUG 22H has the modular dimensions 4U 6C. It is described in the technical overview brochure No. 1MRK 513 001-BEN.

### 1.4 Measuring relay

#### 1.4.1 Compact current relay RXHL 411

The compact current relay RXHL 411 constitutes the measuring relay of RAHL 411 and is available in four different variants.

The compact current relay RXHL 411 is a protective class II equipment in which protection against electric shock does not rely on basic insulation only, but in which additional safety precaution such as double insulation or reinforced insulation are provided.

RXHL 411 is a three-phase static, microprocessor-based relay with four input current transformers for galvanic insulation. The input signals are connected to D/A-converters and then filtered. The signals are sampled in the A/D-converter and read into the microprocessor. The unfiltered input signals are also connected to zero-detectors and read into the microprocessor. All settings of the relay will be done in the local HMI.

The relay is provided with three LED's; one for start, one for trip and one for "in service". The relay is provided with two or six binary inputs and five or nine binary outputs, the binary inputs are galvanically separated from the electronics with optocouplers. The binary outputs consist of electromechanical relays, each with one change over contact. RXHL 411 requires a DC/DC-converter for the auxiliary voltage supply +/-24 V; RXTUG 22H is recommended. The relay is delivered with 4-short-circuiting connectors RTXK for mounting on the rear of the terminal base. The connectors will automatically short-circuit the input currents when the relay is removed from the terminal base.

RXHL 411	Basic version, terminal diagram figure 30
----------	---

RXHL 411	Basic version together with automatic reclosing function, terminal diagram figure 30
RXHL 411	Basic version together with binary I/O module, terminal diagram figure 31
RXHL 411	Basic version together with automatic reclosing function and binary I/O module, terminal diagram figure 31

**Terminal diagrams**

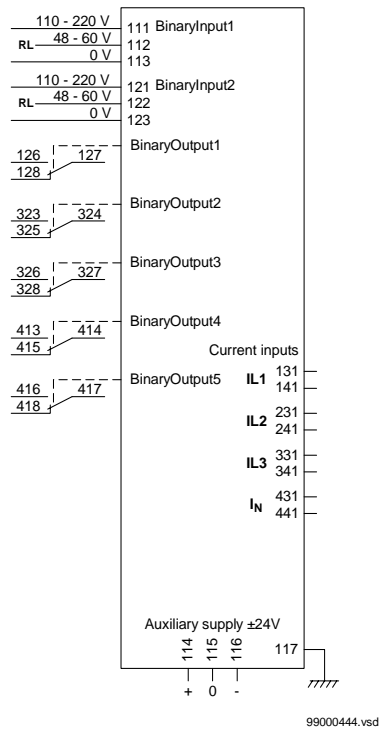

Figure 30: RXHL 411 basic version

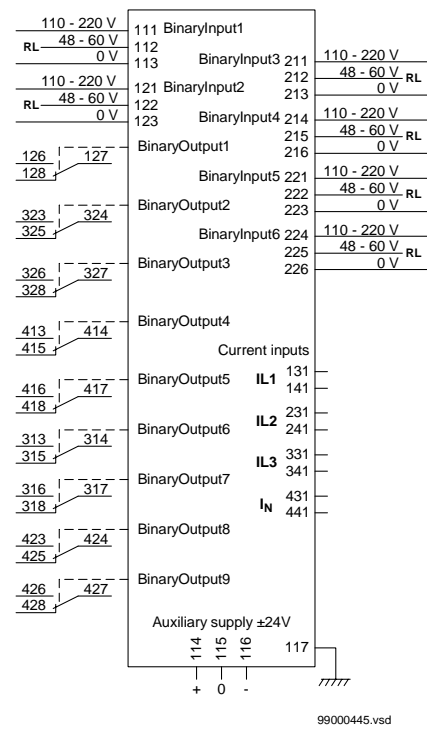
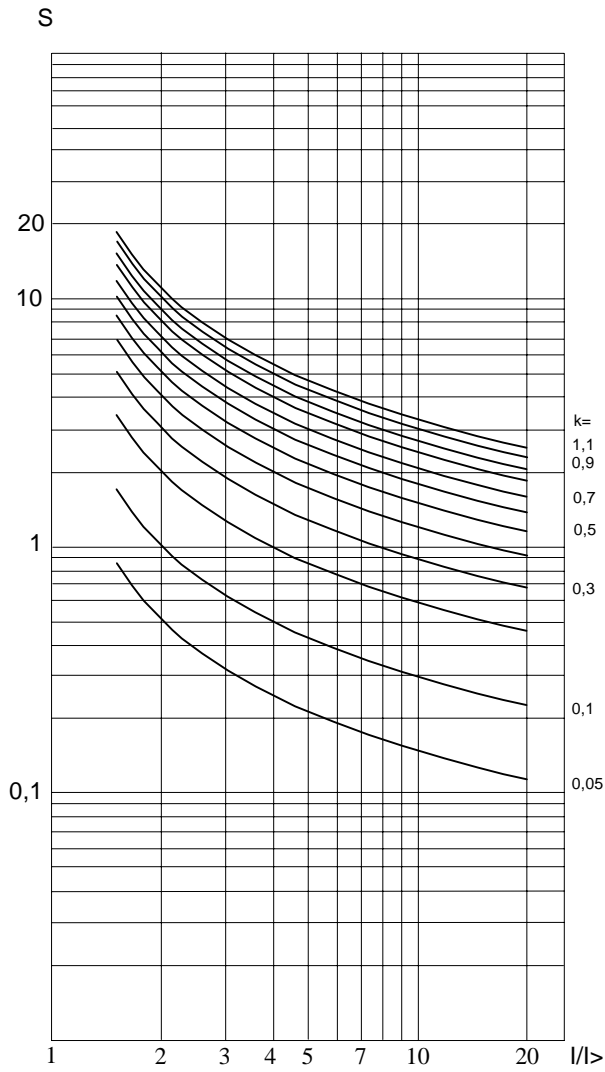
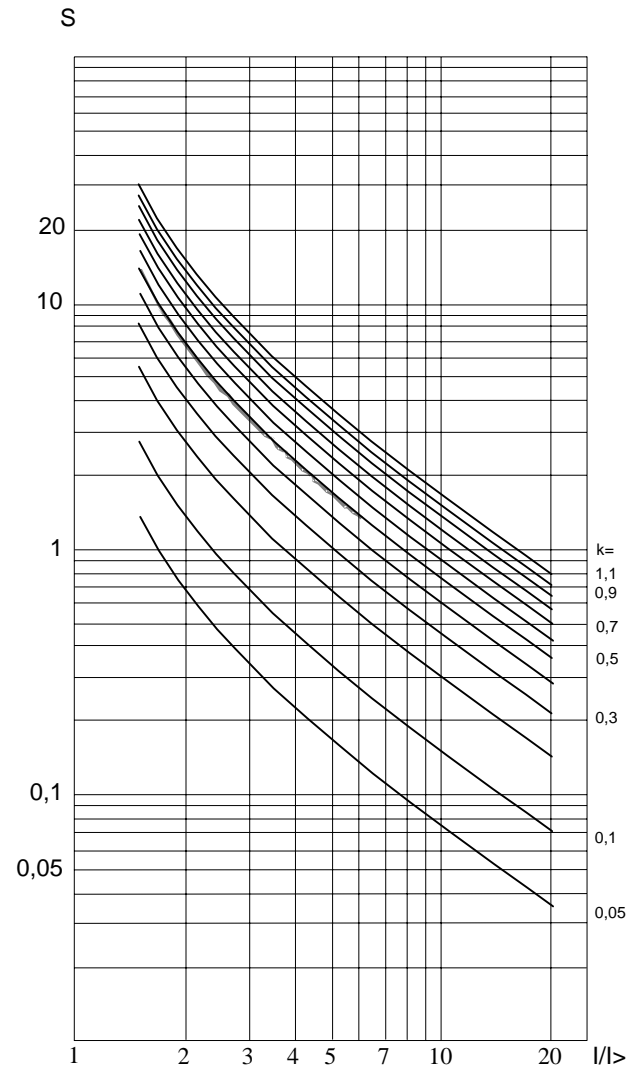

Figure 31: RXHL 411 with binary I/O module

Time characteristics



99000244.vsd



99000245.vsd

Figure 32: Normal inverse time characteristic

Figure 33: Very inverse characteristic

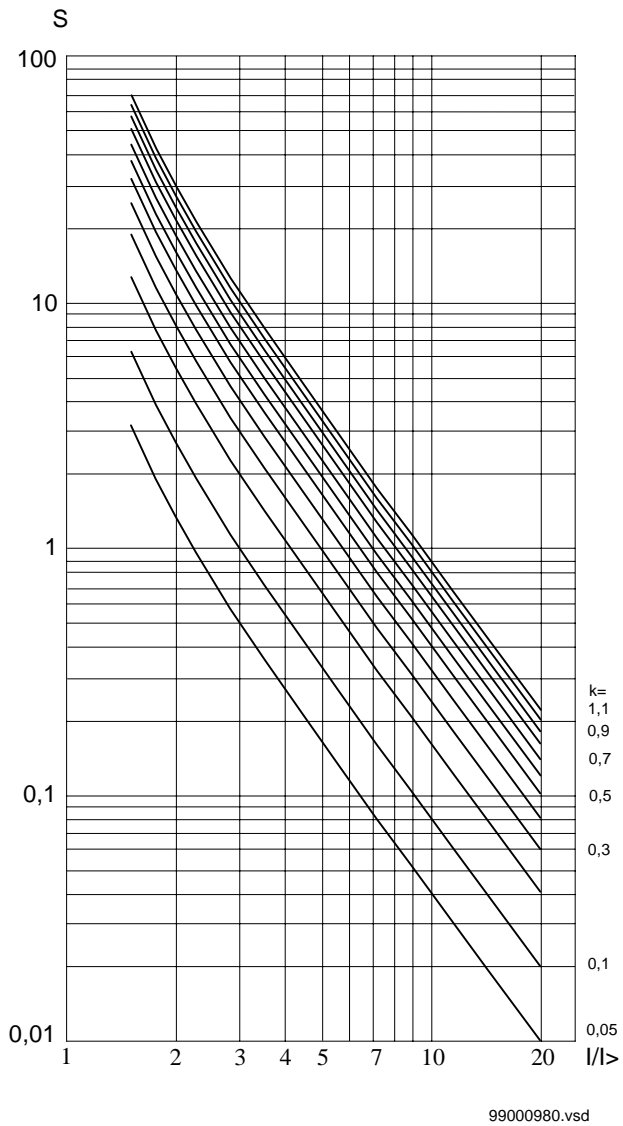

Figure 34: Extremely inverse time characteristic

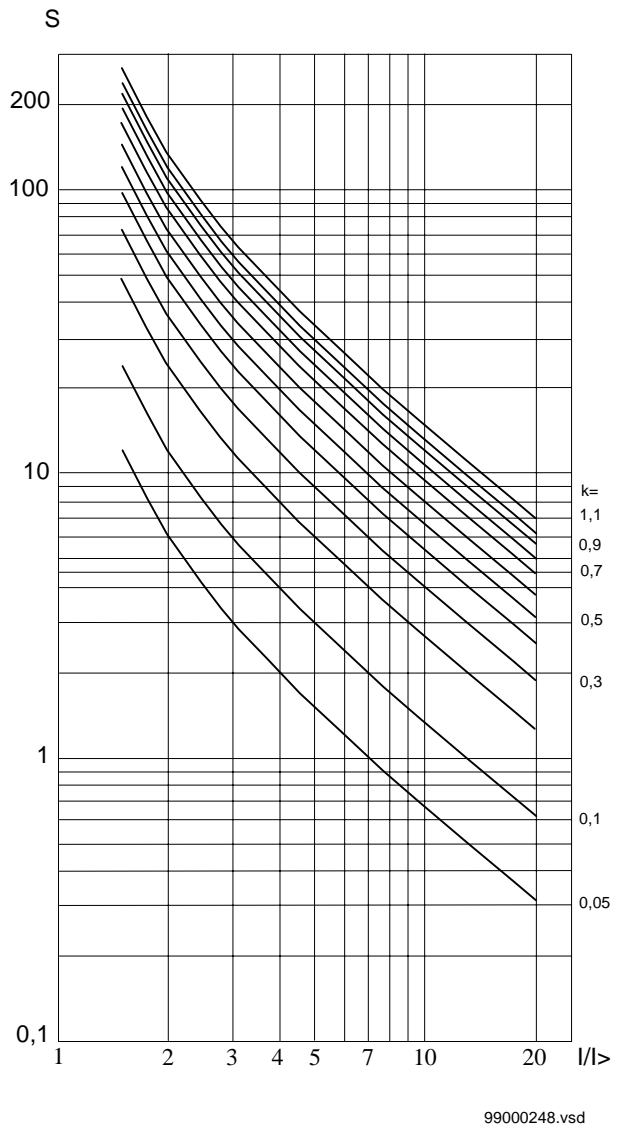

Figure 35: Long-time inverse characteristic

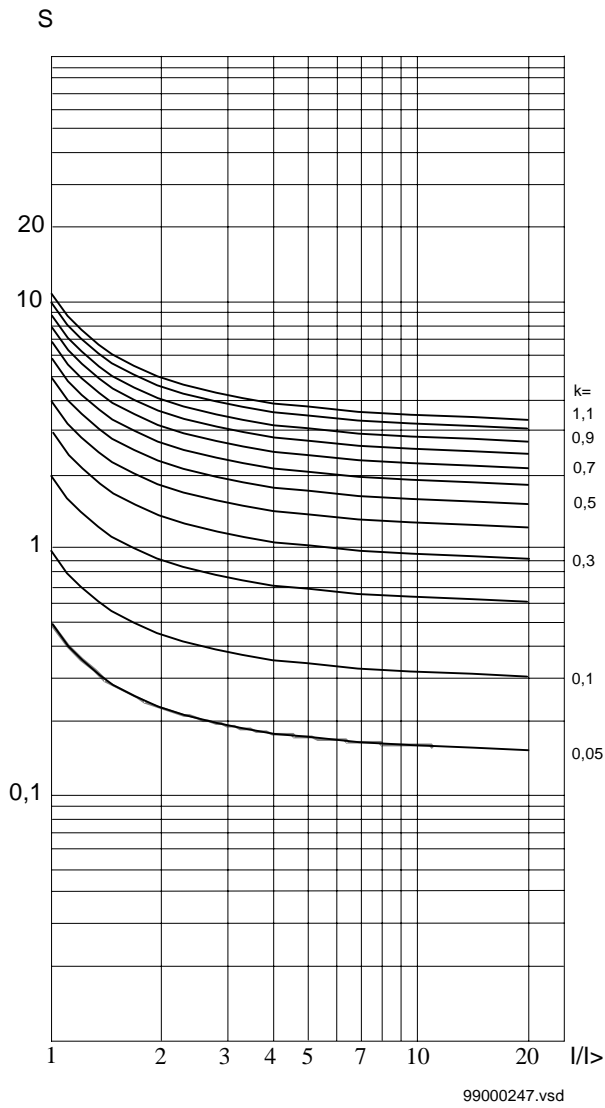

Figure 36: RI inverse time characteristic

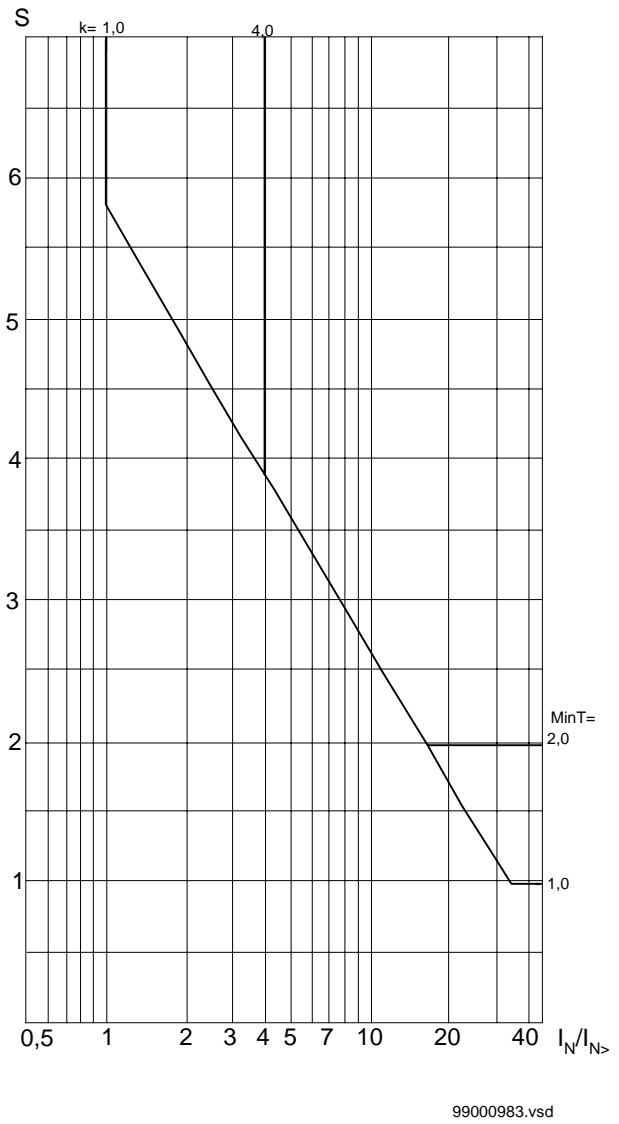
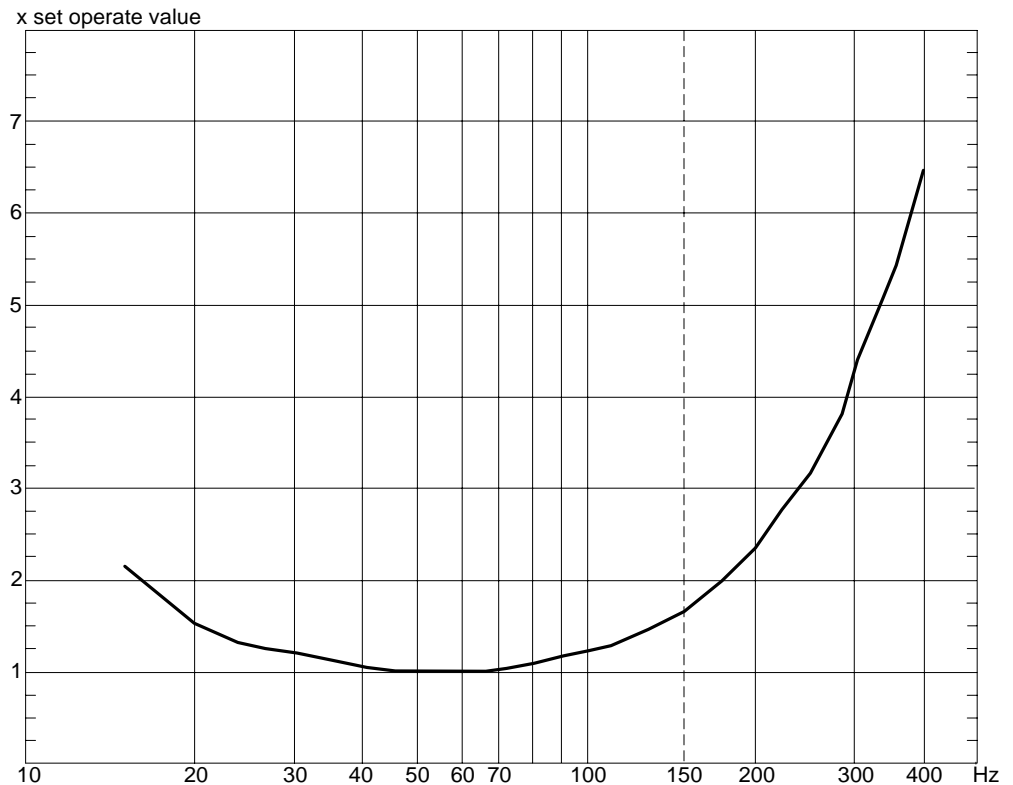

Figure 37: Logarithmic inverse time (IDG) characteristic

### Typical frequency dependence



99001111.vsd

Figure 38: Typical frequency dependence

## 1.4.2

### Binary inputs and outputs

#### Binary inputs

The relay is provided with two or six binary inputs which are galvanically separated from the electronics with opto-couplers. The binary inputs can flexible be configured in the local HMI. A binary input signal or signals can be configured to one or more than one function. Binary input signals are defined as OR functions.

#### Binary outputs

The relay is provided with five or nine binary outputs with change-over contacts. The binary outputs can flexible be configured in the local HMI. A function output signal or signals can be configured to one or more than one binary output. Binary output signals are defined as OR functions.

---

<b>RXHL 4xx</b>	<b>Binary inputs</b>	<b>Binary outputs</b>
Basic version	2	5
Basic version with binary I/O module	6	9

**Binary I/O-test**

The relay is provided with a test function for the binary I/O signals into and out from the relay. Energized binary inputs can be overview via the local HMI. Activation of binary outputs can be done via the local HMI.

**1.5****Tripping relay RXME 18**

The auxiliary relay RXME 18 is used as a tripping relay. It has two heavy duty make contacts and a red flag. The flag will be visible when the armature picks up and is manually reset by a knob in the front of the relay. Typical operate time is 35 ms.

RXME 18 has the modular dimensions 2U 6C. The relay is described in the technical overview brochure No. 1MRK 508 015-BEN.

## 2 Equipment frames and relay cases

The equipment frames and cases are described more detailed in the technical overview brochure No. 1MRK 513 003-BEN. All protection assemblies are mounted on apparatus bars. The apparatus bars are used for the mounting of the COMBIFLEX<sup>®</sup> terminal bases and are screwed directly on the supporting frame by using 3.5 mm tapping screws.

### 2.1 19" equipment frame



These types of equipment frames are used for cubicle mounting or panel mounting of plug-in units in the COMBIFLEX<sup>®</sup> range. The frames are available in 3 sizes for mounting of 20, 40 and 60 module seats respectively:

- 4U (17" x 19")
- 8U (14" x 19")
- 12U (21" x 19")

### 2.2 RHGS cases for 19" cubicle mounting or surface mounting

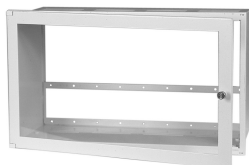

This type of case can be used for all common ways of mounting. The RHGS cases are available in three different sizes, which can be combined with mounting accessories to get maximum flexibility. The cases can also be combined together with the protections in the 500 range. The figure shows a RHGS 30 case.

### 2.3 RHGX cases for flush- or semi-flush panel mounting



The RHGX cases are available in five sizes. The case, a metal box open at the back, has a flange (with a rubber sealing strip) at the front which acts as a stop when the case is inserted into a front panel opening. At the front of the case there is a door with a window and a rubber seal. The figure shows a RHGX 8 case.

### 3 Protection assemblies

The table below shows the different variants of the compact current relay RXHL 411 in protection assemblies type RAHL 411.

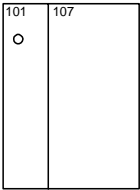
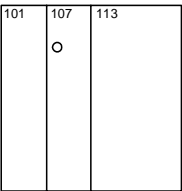
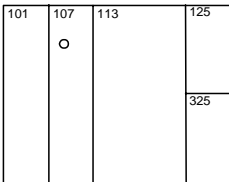
RAHL 411 protection assembly variants	Ordering No.	RXHL 411 options	Circuit diagram	Terminal diagram	Available diagrams
 <p>101 RXTUG 22H 107 RXHL</p>	1MRK 001 082-FA	Basic version	1MRK 001 083-FA	1MRK 001 083-FAA	On request
		With binary I/O	1MRK 001 083-FB	1MRK 001 083-FBA	On request
 <p>101 RTXP 18 107 RXTUG 22H 113 RXHL</p>	1MRK 001 082-GA	Basic version	1MRK 001 083-GA	1MRK 001 083-GAA	On request
		With binary I/O	1MRK 001 083-GB	1MRK 001 083-GBA	On request
 <p>101 RTXP 18 107 RXTUG 22H 113 RXHL 125 RXME 18 325 RXME 18</p>	1MRK 001 082-HA	Basic version	1MRK 001 083-HA	1MRK 001 083-HAA <sup>a)</sup> <sup>b)</sup>	
		With binary I/O	1MRK 001 083-HB	1MRK 001 083-HBA <sup>a)</sup> <sup>b)</sup>	

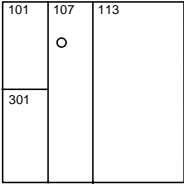
RAHL 411 protection assembly variants	Ordering No.	RXHL 411 options	Circuit diagram	Terminal diagram	Available diagrams
 <p>101 RTXP 8 107 RXTUG 22H 113 RXHL 301 RXME 18</p>	1MRK 001 082-KA	Basic version	1MRK 001 083-KA	1MRK 001 083-KAA	On request
	1MRK 001 082-LA <sup>c)</sup>		1MRK 001 083-LA <sup>c)</sup>	1MRK 001 083-LAA <sup>c)</sup>	b)
		With binary I/O	1MRK 001 083-KB	1MRK 001 083-KBA	On request
			1MRK 001 083-LB <sup>c)</sup>	1MRK 001 083-LBA <sup>c)</sup>	b)

- a) Terminal diagrams available in technical overview brochure for RXHL 411 and RAHL 411
- b) Terminal and circuit diagrams available in installation and commissioning manual for RXHL 411 and RAHL 411
- c) Selection of phase and neutral current must be the same,  $I_r = I_{N_r} = 1 \text{ A}$  or  $I_r = I_{N_r} = 5 \text{ A}$

### 3.1 Mounting alternatives

The protection assemblies described in the table above can be supplied in RHGX or RHGS cases. RXHL 411 compact current relay can also be supplied in the following mounting alternatives.

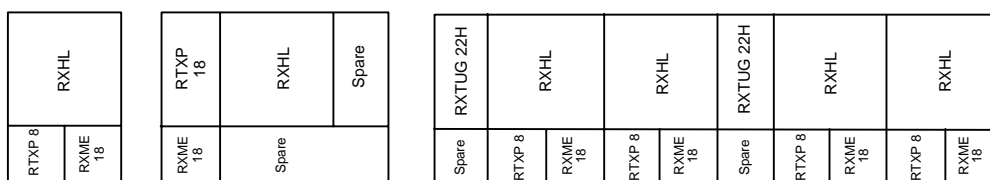

- Mounting of RXHL 411 in RHGS 6.
- Mounting of RXHL 411 in RHGS 12.
- Mounting of RXHL 411 in RHGS 30 with dual power supplies RXTUG 22H, individual test switches and optional tripping relays.



# **Chapter 7 Technical data**

## **About this chapter**

This chapter presents the technical data for the measuring relay and each protection function.

## 1

**Compact current relay RXHL 411****Table 30: Current inputs**

Rated phase current $I_r$		1 A or 5 A	
Rated neutral current $IN_r$	For $I_r = 1$ A	0.1 A or 1 A	
	For $I_r = 5$ A	0.1 A, 1 A or 5 A	
Setting range for the over-current protection	Stage $I>$	$I_r = 1$ A	0.2-3.0 A
		$I_r = 5$ A	1-15 A
	Stage $I>>$	$(1.0-20) \times$ set operate value $I>$	
	Stage $I>>>$	$(1.0-20) \times$ set operate value $I>$	
Setting range for the thermal overload protection	Stage $I\Theta>$	$(0.5-1.0) \times$ set operate value $I>$	
	Thermal heat content $\Theta$	40-200%, $I_b = I\Theta> \times \sqrt{\Theta_{set}/100}$	
Setting range for the earth fault protection	Stage $I_N>$	$IN_r = 0.1$ A	10-250 mA
		$IN_r = 1$ A	0.1-2.5 A
		$IN_r = 5$ A	0.5-12.5 A
	Stage $I_N>>$	$(1.0-20) \times$ set operate value $I_N>$	
	Stage $I_N>>>$	$(1.0-20) \times$ set operate value $I_N>$	
Effective phase current range		$(0.04-60) \times I_r$	
Effective earth current range		$(0.05-50) \times IN_r$	
Rated frequency $F_r$		50 and 60 Hz	
Frequency range		40-60 Hz/50-70 Hz	
Power consumption, per phase at rated current	$I_r = 1$ A	< 30 mVA	
	$I_r = 5$ A	< 150 mVA	
Power consumption, per phase at rated neutral current	$IN_r = 0.1$ A	< 15 mVA	
	$IN_r = 1$ A	< 30 mVA	
	$IN_r = 5$ A	< 150 mVA	

Overload capacity for phase current input	$I_r = 1$ A continuously	4 A
	$I_r = 5$ A continuously	20 A
	$I_r = 1$ A during 1 s	100 A
	$I_r = 5$ A during 1 s	350 A
Overload capacity for neutral current input	$I_{N_r} = 0.1$ A continuously	0.4 A
	$I_{N_r} = 1$ A continuously	4 A
	$I_{N_r} = 5$ A continuously	20 A
	$I_{N_r} = 0.1$ A during 1 s	10 A
	$I_{N_r} = 1$ A during 1 s	100 A
	$I_{N_r} = 5$ A during 1 s	350 A

**Table 31: Binary inputs, basic version**

Inputs		Rated values
Binary inputs		2
Binary input voltage RL		48-60 V DC and 110-220 V DC, -20% to +10%
Power consumption	48-60 V DC	< 0.3 W / input
	110-220 V DC	< 1.0 W / input

**Table 32: Output relays, basic version**

Outputs		Rated values
Contacts		5 change-over
Maximum system voltage		250 V AC/DC
Current carrying capacity	Continuous	5 A
	During 1 s	15 A
Making capacity at inductive load with L/R >10 ms	During 200 ms	30 A
	During 1 s	10 A

Outputs			Rated values
Breaking capacity	AC, $\cos \varphi > 0.4$	max. 250 V	8 A
	DC, $L/R < 40 \text{ ms}$	48 V	1 A
		110 V	0.4 A
		220 V	0.2 A
		250 V	0.15 A

**Table 33: Binary inputs, basic version with binary I/O option**

Inputs		Rated values
Binary inputs		6
Binary input voltage RL		48-60 V DC and 110-220 V DC, -20% to +10%
Power consumption	48-60 V DC	< 0.3 W / input
	110-220 V DC	< 1.0 W / input

**Table 34: Output relays, basic version with binary I/O option**

Outputs			Rated values
Contacts			9 change-over
Maximum system voltage			250 V AC/DC
Current carrying capacity	Continuous		5 A
	During 1 s		15 A
Making capacity at inductive load with $L/R > 10 \text{ ms}$	During 200 ms		30 A
	During 1 s		10 A
Breaking capacity	AC, $\cos \varphi > 0.4$	max. 250 V	8 A
	DC, $L/R < 40 \text{ ms}$	48 V	1 A
		110 V	0.4 A
		220 V	0.2 A
		250 V	0.15 A

**Table 35: Auxiliary DC voltage supply, basic version**

Power consumption			Rated values
Auxiliary voltage EL for RXTUG 22H			24-250 V DC, +/-20%
Auxiliary voltage for the relay			+/-24 V (from RXTUG 22H)
Power consumption with back-light on	With RXTUG 22H, input 24-250 V	Before operation	< 5.0 W
		After operation	< 7.0 W
	Without RXTUG 22H, +/-24 V	Before operation	< 2.7 W
		After operation	< 4.3 W
Power consumption, back-light.			Approximately 0.5 W

**Table 36: Auxiliary DC voltage supply, basic version with binary I/O option**

Power consumption			Rated values
Auxiliary voltage EL for RXTUG 22H			24-250 V DC, +/-20%
Auxiliary voltage for the relay			+/-24 V (from RXTUG 22H)
Power consumption with back-light on	With RXTUG 22H, input 24-250 V	Before operation	< 5.5 W
		After operation	< 8.5 W
	Without RXTUG 22H, +/-24 V	Before operation	< 3.0 W
		After operation	< 5.5 W
Power consumption, back-light.			Approximately 0.5 W

**Table 37: Electromagnetic compatibility (EMC), immunity test**

All tests are performed together with the DC/DC-converter, RXTUG 22H		
Test	Severity	Standard
Surge	1 and 2 kV	IEC 61000-4-5, class 3
AC injection	500 V AC	SS 436 15 03, PL 4
Power frequency magnetic field	1000 A/m	IEC 61000-4-8
1 MHz burst	2.5 kV	IEC 60255-22-1, class 3
Spark	4-8 kV	SS 436 15 03, PL 4
Fast transient	4 kV	IEC 60255-22-4, class 4

All tests are performed together with the DC/DC-converter, RXTUG 22H			
Test	Severity	Standard	
Electrostatic discharge at normal service with cover on	6 kV (contact)	IEC 60255-22-2, class 3	
	8 kV (air)	IEC 60255-22-2, class 3	
	6 kV, indirect application	IEC 61000-4-2, class 3	
Radiated electromagnetic field	10 V/m, 80-1000 MHz	IEC 61000-4-3, Level 3	
Radiated pulse electromagnetic field	10 V/m, 900 MHz	ENV 50204	
Conducted electromagnetic	10 V, 0.15-80 MHz	IEC 61000-4-6, Level 3	
Interruptions in auxiliary voltage	2-200 ms	IEC 60255-11	
No reset for interruptions	24 V DC		< 20 ms
	110 V DC		< 70 ms
	250 V DC		< 300 ms

**Table 38: Electromagnetic compatibility (EMC), emission tests**

All tests are performed together with the DC/DC-converter, RXTUG 22H		
Test	Severity	Standard
Conducted	0.15-30 MHz, class A	EN 50081-2
Radiated	30-1000 MHz, class A	EN 50081-2

**Table 39: CE-demand**

Test	Reference standard
Immunity	EN 50082-2
Emission	EN 50081-2
Low voltage directive	EN 50178

**Table 40: Insulation tests**

Test		Severity	Standard
Dielectric	Current circuit to circuit and current circuit to earth	2.5 kV AC, 1 min	IEC 60255-5
	Circuit to circuit and circuit to earth	2.0 kV AC, 1 min	
	Over open contact	1.0 kV AC, 1 min	
Impulse voltage		5 kV, 1.2/50 $\mu$ s, 0.5 J	IEC 60255-5
Insulation resistance		> 100 M $\Omega$ at 500 V DC	IEC 60255-5

**Table 41: Mechanical test**

Test	Severity	Standard
Vibration	Response: 1 g, 1-150-10 Hz	IEC 60255-21-1, class 2
	Endurance: 1 g, 10-150-10 Hz, 20 sweeps	IEC 60255-21-1, class 1
Shock	Response: 5 g, 11 ms, 3 pulses	IEC 60255-21-2, class 1
	Withstand: 15 g, 11 ms, 3 pulses	
Bump	Withstand: 10 g, 16 ms, 1000 pulses	IEC 60255-21-2, class 1
Seismic	X-axis: 3 g, 1-50-1 Hz	IEC 60255-21-3, class 2, extended (Method A)
	Y-axis: 3 g, 1-50-1 Hz	
	Z-axis: 2 g, 1-50-1 Hz	

**Table 42: Climatic conditions**

Climatic condition	Partially weather protected locations, switch-gear environment, class 3K3
Storage	-40° C to +70° C
Permitted ambient temperature	-5° C to +55° C

**Table 43: Weight and dimensions**

Equipment	Weight	Height	Width
Relay without RXTUG 22H	Approximately 1.3 kg	4U	12C

## 2 Functions

**Table 44: Service values**

Function		Phase-current	Neutral-current
Main CT ratio	Primary value	1.00 A-100 kA	1.00 A-100 kA
	Secondary value	0.40 A-10.0 A	0.40 A-10.0 A
Phase and neutral current (1A and 5A)	Secondary current	0.00-9.99 A	
		10.0-99.9 A	
		100-999 A	
	Primary current	0.00 -9.99 A, kA, MA	
		10.0-99.9 A, kA	
		100-999 A, kA	
Neutral current (0.1 A)	Secondary current	-	0-199 mA
		-	0.20-9.99 A
	Primary current	-	0-199 mA
		-	0.20-9.99 A
		-	0-9.99 kA, MA
		-	10-99.9 A, kA
		-	100-999 A, kA
		-	
Frequency $F_r$	50 Hz	40.0-60.0 Hz	-
	60 Hz	50.0-70.0 Hz	-
	Accuracy	+/- 0.1 Hz	-
Thermal heat content		0-250%	-
Automatic reclosing function		Off, Unready, Ready, Shot1, Shot2, Shot3, Shot4, ReclT, RclTBlk, Unsucce, Blocked	
		Shot 1	0-2997
		Shot 2-4	0-8991
		Unsucce	0-2997

**Table 45: Overcurrent protection**

Overcurrent protection	Stage I>	Stage I>>	Stage I>>>
Setting range	$(0.2-3.0) \times I_r$	$(1.0-20) \times I>$	$(1.0-20) \times I>$
Limiting errors of set operate value for current measuring 50/60 Hz	< 3%	< 3%	< 3%
Consistency of set operate value 50/60 Hz	< 1%	< 1%	< 1%
Typical reset ratio	95%		
Typical operate time $I = 0 \Rightarrow 3 \times$ set operate value	40 ms		
Typical reset time $I = 3 \Rightarrow 0 \times$ set operate value	45 ms		
Transient over-reach $L/R = 50, 100, 200$ and $500$ ms	< 5%		
Typical overshoot time	30 ms		
Recovery time at $I = 3 \times$ set operate value	< 55 ms		
Frequency dependency	$F_r = 50$ Hz (45-55 Hz)	< 5%	
	$F_r = 60$ Hz (54-66 Hz)	< 5%	
	150/180 Hz	Typical 1.5/2.0 x set operate value	
	250/300 Hz	Typical 3.0/4.0 x set operate value	
Influence of harmonics	100/120 Hz, 10%	< 2%	
	150/180 Hz, 20%	< 6%	
	250/300 Hz, 20%	< 3%	
Temperature dependence within range $-5^\circ$ C to $+55^\circ$ C	< 2%		

**Table 46: Time functions for overcurrent protection**

Time function	Stage I>	Stage I>>	Stage I>>>
Time delay	Inverse or definite time (NI, VI, EI, LI and RI)	Definite time	Definite time
Setting range, definite time	0-20 s		
Accuracy, definite time	$\pm 30$ ms		

Time function			Stage I>	Stage I>>	Stage I>>>
Setting range, inverse time			$k = 0.05-1.1$	-	-
Min time, inverse time			0-2.0 s	-	-
Accuracy, inverse time <sup>a)</sup>	NI, VI, EI, LI <sup>b)</sup>	$2.0 \times I_{>set}$	12.5% and +/-30 ms	-	-
		$5.0 \times I_{>set}$	7.5% and +/-30 ms		
		$10.0 \times I_{>set}$	5% and +/-30 ms		
		$20.0 \times I_{>set}$	5% and +/-30 ms		
	RI	$1.0 - 1.3 \times I_{>set}$	12.5% and +/-30 ms	-	-
		$1.3 - 20.0 \times I_{>set}$	5% and +/-30 ms		
Linear reset time			0-500 s	-	-
a) A percentage value of theoretical time and a definite time delay					
b) According to IEC 60225-3, signed error 5.					

**Table 47: Thermal overload protection**

Thermal overload protection	Thermal stage	
Setting range $I_{\Theta>}$	$(0.5-1.0) \times I_{>}$	
Operating range	6 times $I_{\Theta>}$	
Setting range, thermal constant $\tau$	0-120 min	
Thermal heat content	$\Theta$	
Setting range, $\Theta_{set}$	Alarm level	40-200%
	Trip level	40-200%
Reset level	< 2% lower thermal content than operate level	
Maximum thermal heat content	250%	

Thermal overload protection	Thermal stage
Thermal start-up content	0-99%
Operate time	<p>Thermal equation follows the IEC equation:</p> $t = \tau \cdot \ln \frac{I^2 - I_p^2}{I^2 - I_b^2}$ <p>t = operate time                      τ = set time constant                      I<sub>p</sub> = load current before the overload occurs                      I = load current                      I<sub>b</sub> = set operate current                      Θ<sub>set</sub> = alarm or trip level</p> $I_b = I_{\Theta >} \times \sqrt{\Theta_{set} / 100}$
Accuracy operate time	<p>I = +/-1%                      t = +/- (1% of theoretical time and 50 ms )</p>

**Table 48: Earth-fault protection**

Earth-fault protection	Stage I <sub>N&gt;</sub>	Stage I <sub>N&gt;&gt;</sub>	Stage I <sub>N&gt;&gt;&gt;</sub>
Setting range	(0.1-2.5) x I <sub>Nr</sub>	(1.0-20) x I <sub>N&gt;</sub>	1.0-20) x I <sub>N&gt;</sub>
Limiting errors of set operate value for current measuring 50/60 Hz	< 3%	< 3%	< 3%
Consistency of set operate value 50/60 Hz	< 1%	< 1%	< 1%
Typical reset ratio	95%		
Typical operate time I = 0 => 3 x set operate value	40 ms		
Typical reset time I = 3 => 0 x set operate value	45 ms		
Transient over-reach L/R = 50, 100, 200 and 500 ms	< 5%		
Typical overshoot time	30 ms		
Recovery time at I = 3 x set operate value	< 55 ms		

Earth-fault protection		Stage I <sub>N&gt;</sub>	Stage I <sub>N&gt;&gt;</sub>	Stage I <sub>N&gt;&gt;&gt;</sub>
Frequency dependency	F <sub>r</sub> = 50 Hz (45-55 Hz)	< 5%		
	F <sub>r</sub> = 60 Hz (54-66 Hz)	< 5%		
	150/180 Hz	Typical 1.5/2.0 x set operate value		
	250/300 Hz	Typical 3.0/4.0 x set operate value		
Influence of harmonics	100/120 Hz, 10%	< 2%		
	150/180 Hz, 20%	< 6%		
	250/300 Hz, 20%	< 3%		
Temperature dependency within range -5° C to +55° C		< 2%		

**Table 49: Time functions for earth-fault protection**

Time function		Stage I <sub>N&gt;</sub>	Stage I <sub>N&gt;&gt;</sub>	Stage I <sub>N&gt;&gt;&gt;</sub>
Time delay		Inverse, definite or logarithmic time (NI, VI, EI, LI, RI and Log)	Definite time	Definite time
Setting range, definite time		0-20 s		
Accuracy, definite time		+/-30 ms		
Setting range, inverse time		k = 0.05-1.1	-	-
Min time, inverse time		0-2.0 s		
Accuracy, inverse time <sup>a)</sup>	NI, VI, EI, LI <sup>b)</sup>	2.0 x I <sub>&gt;set</sub>	12.5% and +/-30 ms	-
		5.0 x I <sub>&gt;set</sub>	7.5% and +/-30 ms	
		10.0 x I <sub>&gt;set</sub>	5% and +/-30 ms	
		20.0 x I <sub>&gt;set</sub>	5% and +/-30 ms	
	RI	1.0-1.3 x I <sub>&gt;set</sub>	12.5% and +/-30 ms	
		1.3-20.0 x I <sub>&gt;set</sub>	5% and +/-30 ms	
Setting range, logarithmic time (IDG)		k = 1-4		
Min time, logarithmic time		1.0-2.0 s		
Formula, logarithmic time		t = 5.8-1.35 x ln (I/I <sub>Nset</sub> )		
Accuracy, logarithmic time		+/-50 ms overall		

Time function	Stage I <sub>N&gt;</sub>	Stage I <sub>N&gt;&gt;</sub>	Stage I <sub>N&gt;&gt;&gt;</sub>
Linear reset time	0-500 s	-	-
a) A percentage value of theoretical time and a definite time delay			
b) According to IEC 60255-3, signed error 5			

**Table 50: Breaker failure protection**

Function	Setting range
Activates by trip signals from	I>, I>>, I>>>, Θ>, I <sub>N&gt;</sub> , I <sub>N&gt;&gt;</sub> , I <sub>N&gt;&gt;&gt;</sub> external start and intentional overreach trip
Activation level, overcurrent function	50-200% of set overcurrent function, I>
Activation level, earth-fault function	50-200% of set earth-fault function, I <sub>N&gt;</sub>
Operate time, back-up trip	0.10-1.00 s
Overshoot time	< 30 ms

**Table 51: Automatic reclosing function**

Function	Setting range	
Reclosing program	3-phase reclosing	
Activates by trip signals from	I>, I>>, I>>>, I <sub>N&gt;</sub> , I <sub>N&gt;&gt;</sub> , I <sub>N&gt;&gt;&gt;</sub> and intentional overreach trip	
Number of reclosing shots	1-4	
Open time before reclosing	Dead-time shot 1	0.2-60 s
	Dead-time shot 2	1.0-300 s
	Dead-time shot 3	1.0-300 s
	Dead-time shot 4	1.0-300 s
Reclaim time	10-300 s	
Reclosing pulse	50-200 s (depending on new start pulse)	
Binary input: automatic reclosing	On-off	
Binary input: CB closed	Yes, closed 5 s before start	
Binary input: CB ready	Yes	
Binary input: block automatic reclosing	Yes, reset delay 5 s	

**Table 52: Intentional overreach trip function**

<b>Function</b>	<b>Setting range</b>
Operation criteria	Before first reclosing
Activates by start signals from	I>, I>> and I>>>
Time delay for fuse selectivity	0.00-10.0 s

# Chapter 8 Ordering

## **About this chapter**

This chapter contains ordering tables which should be used when ordering.



<b>Mounting alternatives</b>	<b>Size</b>		
Apparatus bars (always included)			
Equipment frame without door	4U 19"	<input type="checkbox"/>	1MRK 000 137-GA
Equipment frame with door	4U 19"	<input type="checkbox"/>	1MRK 000 137-KA
RHGX 4	4U 12C	<input type="checkbox"/>	RK 927 001-AB
RHGX 8	4U 24C	<input type="checkbox"/>	RK 927 002-AB
RHGX 12	4U 36C	<input type="checkbox"/>	RK 927 003-AB
RHGX 20	4U 60C	<input type="checkbox"/>	RK 927 004-AB
RHGS 30	6U x 1/1 19" rack	<input type="checkbox"/>	1MRK 000 315-A
RHGS 12	6U x 1/2 19" rack	<input type="checkbox"/>	1MRK 000 315-B
RHGS 6	6U x 1/4 19" rack	<input type="checkbox"/>	1MRK 000 315-C

**1.3****Accessories****User documentation RXHL 411 and RAHL 411**

Operator's manual	Quantity:	<input type="text"/>	1MRK 509 050-UEN
Technical reference manual	Quantity:	<input type="text"/>	1MRK 509 051-UEN
Installation and commissioning manual	Quantity:	<input type="text"/>	1MRK 509 052-UEN





