

Operator's manual

RXHL 421 and RAHL 421

Compact current relay and protection assemblies

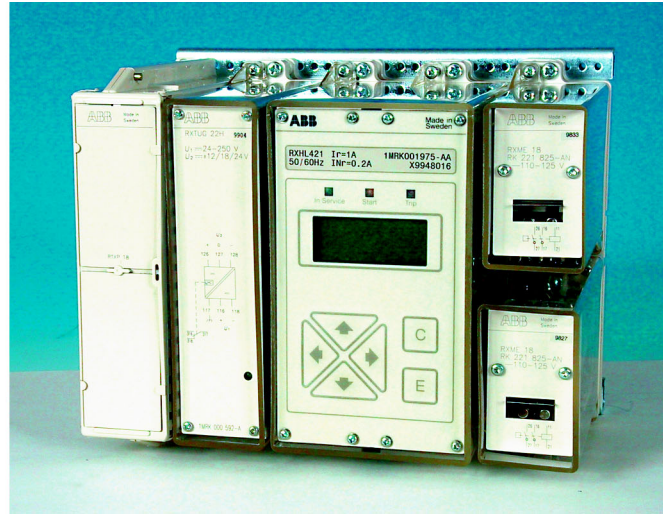

About this manual

DocID: 1MRK 509 054-UEN
Issue date: December 2001
Change date: Since May 2000
Version: 1.0
Revision: A

© ABB Automation Technology Products AB 2001
Substation Automation

COPYRIGHT

WE RESERVE ALL RIGHTS TO THIS DOCUMENT, EVEN IN THE EVENT THAT A PATENT IS ISSUED AND A DIFFERENT COMMERCIAL PROPRIETARY RIGHT IS REGISTERED. IMPROPER USE, IN PARTICULAR REPRODUCTION AND DISSEMINATION TO THIRD PARTIES, IS NOT PERMITTED.

THIS DOCUMENT HAS BEEN CAREFULLY CHECKED. IF THE USER NEVERTHELESS DETECTS ANY ERRORS, HE IS ASKED TO NOTIFY US AS SOON AS POSSIBLE.

THE DATA CONTAINED IN THIS MANUAL IS INTENDED SOLELY FOR THE PRODUCT DESCRIPTION AND IS NOT TO BE DEEMED TO BE A STATEMENT OF GUARANTEED PROPERTIES. IN THE INTERESTS OF OUR CUSTOMERS, WE CONSTANTLY SEEK TO ENSURE THAT OUR PRODUCTS ARE DEVELOPED TO THE LATEST TECHNOLOGICAL STANDARDS. AS A RESULT, IT IS POSSIBLE THAT THERE MAY BE SOME DIFFERENCES BETWEEN THE HW/SW PRODUCT AND THIS INFORMATION PRODUCT.

Manufacturer:

ABB Automation Technology Products AB
Instrumentation & Control
Substation Automation
SE-721 59 Västerås
Sweden
Tel: +46 (0) 21 34 20 00
Fax: +46 (0) 21 14 69 18

Chapter	Page
Chapter 1 Introduction	1
Introduction to the operator's manual	2
About this manual	2
Intended audience	2
Related documents	3
Revisions	3
Chapter 2 Safety information	5
Safety signs	6
Description of safety signs	6
Warning signs	6
Note signs	6
Chapter 3 Human-machine-interface	7
Local human-machine-interface (HMI)	8
Overview	8
LED indication	9
Graphic LCD-display	9
Menu window	9
Saving dialog	10
Push-buttons	10
Menu tree	12
Chapter 4 Operations during normal service	13
Overview	14
Using the service values menu	15
Reading primary service values	15
Service values menu	15
Using the indications menu	17
Reading disturbance information	17
Indications menu	18

Chapter 1 Introduction

About this chapter

This chapter introduces the user to the content in the manual. The intended use of the manual and the intended audience is described. The introduction chapter also contains references to other documents.

1 Introduction to the operator's manual

1.1 About this manual

The operator's manual is intended to be used by the operator during normal service when the plastic cover, which covers the relay, is not removed. The manual does not contain any instructions for commissioning or testing and the protection has therefore to be commissioned and tested before any of the instructions in this manual could be carried out. The manual describes how the local human-machine-interface (HMI) is used and how to read off service values and disturbance information.

The operator's manual contains the following chapters:

- The *safety information* chapter presents warning and note signs, which the user should draw attention to.
- The *human machine interface* chapter contains descriptions about the local human-machine-interface (HMI).
- The *operations during normal service* chapter contains instructions on how to handle the service value menu and the indications menu during normal service.

1.2 Intended audience

1.2.1 General

The operator's manual is addressing the operator, responsible for operating the protection on a daily basis. This includes reading off service values and clearing disturbances.

1.2.2 Requirement

The personnel who operate the protection must be experienced and have a basic knowledge in using protection equipment. The manual contains words which are commonly used when describing this kind of protection equipment.

1.3**Related documents**

Document related to COMBIFLEX[®] assemblies	Identity number
Buyer's guide, Connection and installation components in COMBIFLEX [®]	1MRK 513 003-BEN
Buyer's guide, Relay accessories and components	1MRK 513 004-BEN
Buyer's guide, Test system COMBITEST	1MRK 512 001-BEN
Buyer's guide, DC-DC converter	1MRK 513 001-BEN
Buyer's guide, Auxiliary relays	1MRK 508 015-BEN

Documents related to RXHL 421 and RAHL 421	Identity number
Technical overview brochure	1MRK 509 053-BEN
Connection and setting guide (only RXHL 421)	1MRK 509 053-WEN
Operator's manual	1MRK 509 054-UEN
Technical reference manual	1MRK 509 055-UEN
Installation and commissioning manual	1MRK 509 056-UEN

1.4**Revisions**

Revision	Description
-	Initial version
A	New version of RXHL 421 1MRK001975-AB, directional earth-fault function improved for intermittent faults in cables.

Chapter 2 Safety information

About this chapter

This chapter contains safety information. Warning and note signs are presented which attend the user to be careful during certain operations in order to avoid human injuries or damage to equipment.

1 Safety signs

1.1 Description of safety signs

1.1.1 The warning sign

The warning sign informs the user that certain operations should be avoided in order to prevent human injuries or damage to equipment.

1.1.2 The note sign

The note sign informs the user to be careful when using the product in certain situations and notifies the user to facts that could be of special interest during certain operations.

1.2 Warning signs



Warning!

Always avoid to touch the circuitry when the plastic cover, which covers the relay, is removed. The product contains electronic circuitries which can be damaged if exposed to static electricity (ESD). The electronic circuitries also contain high voltage which is lethal to humans.

1.3 Note signs



Note!

If the LED's are flashing or the green 'In service' LED is dark, an internal fault has occurred. Read the self supervision section in the technical reference manual for further information.

Chapter 3 Human-machine-interface

About this chapter

This chapter describes the human-machine-interface (HMI) on the front of the protection towards the user. The chapter contains descriptions on the different parts and how they are used. The chapter also contains descriptions on how different menus and dialogs, such as the main menu and the saving dialog, are used.

1 Local human-machine-interface (HMI)

1.1 Overview

The local human-machine-interface (HMI) provides local communication between the user and the relay. Disturbance information, service values and setting parameters etc. are available via the local HMI.

The HMI module includes three light emitting diodes (LED), a graphic LCD-display and six push-buttons. The LEDs on the HMI provide the primary status information of the relay and the display provides more detailed information. The HMI is also used for relay configuration and for reading off service values and disturbances.

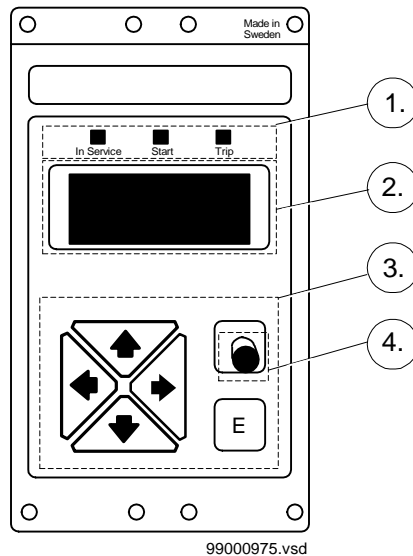

1. Light emitting diodes (LED)
2. Graphic LCD-display
3. Push buttons
4. Cover button (when plastic cover is on)

Figure 1: Local human-machine-interface (HMI) front panel

1.2 LED indication

Green LED	The operating condition of the relay is normal.
Yellow LED	Indicates start and can be configured in HMI to be latched or not.
Red LED	Indicates trip and can be configured in HMI to be latched or not.

1.3 Graphic LCD-display

The graphic liquid crystal display (LCD) provides primary status information of the relay. It is normally dark. The display turns off automatically after leaving the menu tree or approximately 30 minutes after any button has been pressed. This function can be selected to be on or off.

1.4 Menu window

The menu window presents the paths and the menus in the relay.

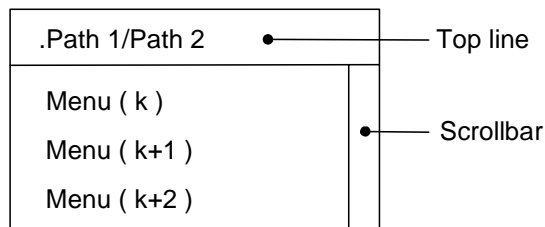

99000149.vsd

Row one, Top line:

- If the path presents more than two menu levels a dot will appear at the beginning of the row.
- Path 1 presents the name of the previous menu.
- Path 2 presents the name of the active menu.

Row two, three and four:

- Menus k, k+1 and k+2 appear in the three bottom rows.
- When the cursor highlights one of the rows, it indicates the path the user can activate by selecting the right arrow or the 'E' button.

When more than four rows are available a scroll bar appears at the right side and indicates where the cursor is. To change the active path within the menu tree press the up or down arrow button.

1.5

Saving dialog

The saving dialog will appear when moving upwards in the menu tree from a menu which consists of editable values or configurations. The saving dialog window lets the user to choose a command YES, NO or CANCEL, by using the left or right arrow button. Confirm with the 'E' button.

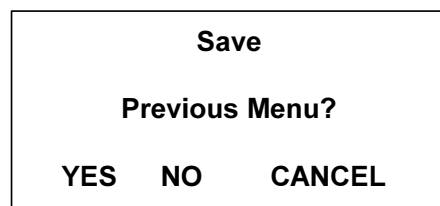

99000150.vsd

YES	Save the previous setting(s) and exit.
NO	Exit the menu without saving any changes.
CANCEL	Returns to the previous setting(s) or to the previous menu.

1.6

Push-buttons

The number of buttons used on the local HMI is reduced to the minimum acceptable amount to make communication as simple as possible for the user. The buttons normally have more than one function, depending on where they are used in the menu tree.

All buttons have one function in common: when the display is in idle (dark, non activate) mode, selecting any of them results in activation of the display.

Push button Let you...

1. Move upwards in menu tree.
2. Turn-off display at main menu.
3. Read service values and disturbance information.



1. Confirm choices in menu.
2. Move downwards in menu tree.

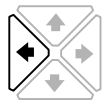

1. Move left in dialog boxes and editable menus.
2. Move upwards in menu tree.
3. Turn-off display at main menu.



1. Move right in dialog boxes and editable menus.
2. Move downwards in menu tree.



1. Move upwards in specific menu.
2. Increase editable values.
3. Select choice in dialog box and configuration.



1. Move downwards in specific menu.
2. Decrease editable values.
3. Select choice in dialog box and configuration.

2

Menu tree

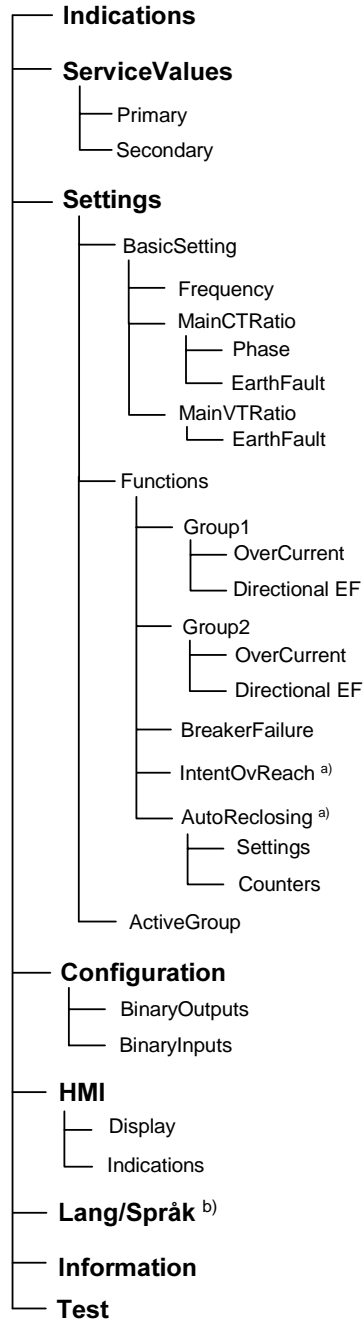

^{a)} Functions available as options

^{b)} English and the other available language is swedish

en00000142.vsd

Chapter 4 Operations during normal service

About this chapter

This chapter contains instructions on how primary service values and disturbance information can be retrieved during normal service without removing the plastic cover which covers the relay.

1

Overview

Before these task can be performed the relay has to be installed and commissioned according to the instructions given in the installation and commissioning manual.

There are basically two operations that can be performed in normal service mode without removing the plastic cover. The operator can view the primary service values and check the disturbance information. The operator can also clear the stored disturbance which has occurred. The secondary values are only possible to retrieve when the plastic cover is removed. The cover-button located on the plastic cover is used for browsing the different menus.

**Note!**

If the LED's are flashing or the green 'In service' LED is dark, an internal fault has occurred. Read the self supervision section in the technical reference manual for further information.

2 Using the service values menu

2.1 Reading primary service values

This section describes how the user can read the primary service values during normal service when the plastic cover is not removed.

The primary service values can be viewed during normal service by pressing the cover-button located on the plastic cover that covers the relay. If a disturbance has occurred the indication menu will be presented when pressing the cover-button.

Procedure

1. **Press the cover-button located on the plastic cover.**
The display on the local HMI lights up and presents the first set of service values.
2. **Press the cover-button to present the second set of service values.**
3. **Press the cover-button to present the status of the automatic reclosing function.**
4. **Press the cover-button to turn-off the display.**

2.2 Service values menu

The following values are presented when the service value menu is viewed:

Service value	Provides information about
IL1	The actual phase-1 current
IL2	The actual phase-2 current
Θ	The actual thermal heat content
U_N	The actual neutral point voltage
I_N	The actual non-directional neutral current
$\cos\varphi$	The actual $\cos\varphi$ value -1.00 to 1.00, at characteristic angle α the $\cos\varphi$ value is 1.00. The phase angle φ between U_N and I_N is positive when I lags U
Freq	The actual frequency

Service value		Provides information about
AutoRec	OFF	Automatic reclosing function is turned off
	Unready	Automatic reclosing function is not ready for a reclosing cycle
	Ready	Automatic reclosing function is ready for a reclosing cycle
	Shot1	Dead-time for shot 1 is counting
	Shot2	Dead-time for shot 2 is counting
	Shot3	Dead-time for shot 3 is counting
	Shot4	Dead-time for shot 4 is counting
	ReclT	Reclaim time is counting
	RclTBlk	Reclaim time is counting and if a a new start occurs the reclosing will be unsuccessful
	Unsucce	Unsuccessful reclosing
	Blocked	Automatic reclosing function is blocked
Shot1	The total numbers of first reclosing attempts	
Shot2-4	The total numbers of second to fourth reclosing attempts	
Unsucce	The total numbers of unsuccessful reclosing attempts	

3 Using the indications menu

3.1 Reading disturbance information

This section describes how the user can read the recorded disturbances during normal service when the plastic cover is not removed.

Disturbance information can be checked and cleared during normal service by pressing the cover-button located on the plastic cover that covers the relay. If the user press the cover-button and no disturbance has occurred, the service values will be presented.

Procedure

1. Press the cover-button located on the plastic cover.

The display on the local HMI lights up and presents the status of the overcurrent functions and active setting group.

2. Press the cover-button to present the remaining status of the overcurrent functions, thermal overload function and active setting group.

3. Press the cover-button to present status of the earth-fault functions and active setting group.

4. Press the cover-button to present status of the breaker failure function and intentional overreach function.

5. Press the cover-button to present the recorded primary trip values.

6. Press the cover-button to present the remaining primary trip values.

7. Press the cover-button and the display presents the clearing dialog box.

Here the recorded disturbances can be cleared or not.

8. Press and hold down the cover-button for more than two seconds to clear the disturbances or press the button shortly to not clear the disturbances.

If the user choose to clear the disturbances, the saved values and LED's will be cleared. After the decision the display will present the first set of service values.

9. Press the cover-button to present the second set of service values.

10. Press the cover-button to present the status of the automatic reclosing function.

11. Press the cover-button to turn-off the display.

The display will return to the main menu and idle mode.

3.2**Indications menu**

The following indications are presented when the indications menu is entered. Stored primary trip values are always from the last disturbance and will also be presented through this menu.

Indication	Start	Trip	Function description
I>	<input type="checkbox"/> 1/2	<input type="checkbox"/> 1/2	Status and active group for overcurrent, low set stage.
	L12		Phase indication which caused the start on I>
I>>	<input type="checkbox"/> 1/2	<input type="checkbox"/> 1/2	Status and active group for overcurrent, medium set stage.
	L12		Phase indication which caused the start on I>>
I>>>	<input type="checkbox"/> 1/2	<input type="checkbox"/> 1/2	Status and active group for overcurrent, high set stage.
	L12		Phase indication which caused the start on I>>>
Θ>	<input type="checkbox"/> 1/2	<input type="checkbox"/> 1/2	Status and active group for thermal overload.
U _N >	<input type="checkbox"/> 1/2	<input type="checkbox"/> 1/2	Status and active group for neutral point voltage stage.
I _{->N} >	<input type="checkbox"/> 1/2	<input type="checkbox"/> 1/2	Status and active group for directional earth-fault stage.
ReTrip		<input type="checkbox"/>	Status for breaker failure, re-trip.
BckUpTr		<input type="checkbox"/>	Status for breaker failure, back-up trip.
IntOvTr		<input type="checkbox"/>	Status for intentional overreach trip.

Number 1 or 2 (start and trip) above indicates which setting group that was active during the disturbance. All start functions are connected to the yellow LED and all trip functions are connected to the red LED. The appearance of the boxes in the local HMI describes the status of the function.

Filled (black)	Latest recorded event.
Grayed	Previous recorded event.
Blank	No recorded event (since last clearing).

Recorded trip values	Provides information about
IL1	The recorded phase-1 current
IL2	The recorded phase-2 current
U_N	The recorded neutral point voltage
I_N	The recorded non-directional neutral current
$\cos\varphi$	The recorded $\cos\varphi$ value -1.00 to 1.00, at characteristic angle α the $\cos\varphi$ value is 1.00. The phase angle φ between U_N and I_N is positive when I lags U

