

User's Manual

HV/Voltage Control*2.3



This manual belongs to:

Chapter	Page
About this manual	5
<hr/>	
Introduction	7
<hr/>	
Instructions	11
<hr/>	
Technical descriptions	27
<hr/>	
Appendix	55
<hr/>	
Software Registration Form	77
<hr/>	
Customer feedback report	79
<hr/>	
Index	81
<hr/>	

This is a User's guide for HV/Voltage Control*2.3

Document number: 1MRK 511 116-UEN

Revision: B

Issue date: March 2005

Data subject to change without notice

We reserve all rights to this document, even in the event that a patent is issued and a different commercial proprietary right is registered. Improper use, in particular reproduction and dissemination to third parties, is not permitted.

This document has been carefully checked. If the user nevertheless detects any errors, he is asked to notify us as soon as possible.

The data contained in this manual is intended solely for the product description and is not to be deemed to be a statement of guaranteed properties. In the interests of our customers, we constantly seek to ensure that our products are developed to the latest technological standards.

As a result, it is possible that there may be some differences between the HW/SW product and this information product.

Author's address:

ABB Automation Technologies AB
Substation Automation Products
SE-721 59 Västerås
Telephone: +46 (0) 21 34 20 00
Facsimile: +46 (0) 21 14 69 18
Internet: www.abb.com/substationautomation

© Copyright 2005 ABB. All rights reserved.

The chapter “Introduction”

Introduction	9
Preface.....	9
Abbreviations and definitions	9
Font conventions.....	10

1 Introduction

1.1 Preface

Welcome to the HV/Voltage Control User's Guide. This document will provide you with the necessary information for installing, configuring and modifying the different parts in the HV/Voltage Control package.

To be able to understand this document the user should be familiar with MicroSCADA and MicroLIBRARY.

The functions described here are designed and created by ABB Automation Technology Products AB in Västerås, Sweden.

1.2 Abbreviations and definitions

Base picture	Background picture, including menu bar. The base on which standard functions are installed.
BBONE	Back Bone
HV	High voltage
HV/Voltage Control	The program package for the voltage control function part of LIB520.
HW	Hardware
LAN	Local Area Network
LIB500	Application Library 500, the common platform for ABB application engineering within MicroSCADA
LIB520	High Voltage MicroLIBRARY
LON	Local Operating Network
MicroLIBRARY	Application Library, previous version to LIB 500
MV	Medium voltage
Process symbol	Graphical presentation of a standard function in run-time.
SCT	Standard Configuration Tool
SIT	Standard Installation Tool
SLIB	Help tool for development of dialogue pictures.
SCS	Substation Control System. A system for monitoring and controlling a complete substation. In this document the system is MicroSCADA.
SW	Software
TCP/IP	Transmission Control Protocol/Internet Protocol.

1.3

Font conventions

Normal text is written with this font and size.

SCIL CODE, SCIL PROGRAMS AND FILE NAMES ARE WRITTEN WITH THIS FONT AND SIZE.

The chapter “Instructions”

System requirements	13
Terminal end	13
The MicroSCADA PC.....	13
The HV/Voltage Control package	13
Installation	14
Installation of MicroSCADA software	14
Installation of the HV/Voltage Control software package	14
Readme file	15
Location of the HVLib functions	16
Creating and preparing an application	16
Station type	16
Object identifier	17
Installing and configuring	18
Installation tool	18
Standard Configuration Tool	19
Process Object Tool.....	19
Representation Tool.....	19
Color Tool	20
The HV/Voltage Control function	20
Installation process	23
Delete process	24
Voltage control measurements	24
Installation process	25
Delete process	25
Additional application engineering	25
Switch state.....	25
Addressing the process objects	25
Remaining tasks	25

1 System requirements

In order to operate, the software module HV/Voltage Control poses the following requirements on its environment.

1.1 Terminal end

Remote SPA-bus communication or LON-bus communication. The following terminal is supported:

- RET 521*2.1
- RET 521*2.3
- RET 521*2.4
- RET 521*3.1

1.2 The MicroSCADA PC

- MicroSYS revision 8.4.4 or later
- LIB500 revision 4.0.4 or later
- LIB 520 revision 4.0.4 or later

1.2.1 The HV/Voltage Control package

- 900 kB disk space

2 Installation

Before using HV/Voltage Control the software has to be installed on the hard disk of the MicroSCADA computer. (HV/Control must be installed before HV/Voltage Control)

Installation has two meanings.

1 Installing the software:

- Installation of the HV/Voltage Control software module means copy of the files from the diskette to the hard disk.

2 Installing the library functions:

- Installation of a HV/Voltage Control library function means installation of the library function in to a picture by means of Standard Installation Tool and creation of necessary database.

Note!

In order to avoid problems, it is recommended not to have the MicroSCADA active during the installation.



2.1 Installation of MicroSCADA software

Before the installation of the HV/Voltage Control package can take place, the user must make sure that the MicroSCADA software is already installed on the PC.

2.2 Installation of the HV/Voltage Control software package

To install from the disk-drive to the hard disk, please follow the steps below:

- Start up the Explorer
- Run [drive]:\LIB520_XXX.EXE
- Follow the instructions on the screen
- The HV/Voltage Control package is now properly installed on the hard disk of the PC.
- After installation - read and follow any package specific instruction in the Readme file. See “Readme file” on page 15.
- Start the MicroSCADA

The software is now installed in the following directories:

```
[drive]:\SC\LIB4\SMOD\HVPROCESS\INST  
[drive]:\SC\LIB4\SMOD\HVPROCESS\LANG0  
[drive]:\SC\LIB4\SMOD\HVPROCESS\USE
```

The following files are also added by the installation:

```
[drive]:\SC\LIB4\BASE\BBONE\USE\PATH4_S1.TXT  
[drive]:\SC\LIB4\BASE\BBONE\INST\INDEX4_S3.TXT
```

these two files are used by the system to update the LIB 500 files:

```
[drive]:\SC\LIB4\BASE\BBONE\USE\PATH4.TXT  
[drive]:\SC\LIB4\BASE\BBONE\INST\MLIB_INDEX.TXT
```

See also “Updated files” on page 75 regarding the additions to the files above.

Note:

The difference of library separators in Windows “\” and MicroSCADA “/”.

After the installation, you should have a structure according “Location of the HVLib functions” on page 16.

2.3

Readme file

It is important to read and follow the instructions in the README.TXT file, which is installed to the directory

```
[drive]:\SC\LIB4\SMOD
```

Any specific release information, known errors and limitations are stated in this file. It is therefore very important that you ALWAYS read the README.TXT file.

2.4

Location of the HVLib functions

HVLib functions are stored on to hard disk in the following way:

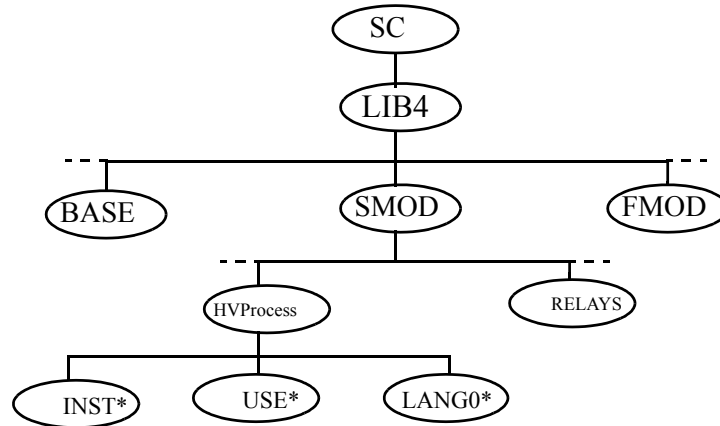

Fig. 2.1 HVLib directory structure.

* These directories are mostly used with their logical path names S_INST, S_USE and S_LANG defined in file PATH4_S1.TXT

3

Creating and preparing an application

Note: Before reading any further, please read at least the overview and tutorials starting on page 29.

The following steps are essential when creating a new application and preparing it for use with HV/Voltage Control functions.

- Consider and define the *Authorization grouping*. The *Authorization levels* can be defined later. The setup is taken in account during standard function configuration. The *Authorization grouping* is defined in the User Management tool.
- Setup the *APL:BSV15* in SYS_BASCON.COM for OI attribute in Process database. See “Object identifier” on page 17.
- The installed function demands that *process objects* are created to work properly in run-time mode. This will avoid error codes appear.

3.1

Station type

The default value when configuring the objects is LON (station type REX). The SPA type can optionally be selected. If LON is selected, the process objects are created without bit numbers.

3.2

Object identifier

Before installation the use of the attribute OI (Object Identifier) must be decided.

Open SYS_BASCON.COM via MicroSCADA Control Panel/Admin/Config. In the system configuration file SYS_BASCON.COM locate the following section:

```
;*****
;
;      APPLICATIONS
;The usage of OI & OX -attributes (required by LIB 500)
@SV(15) = LIST(-
      Process_Objects=LIST(-
        OI=LIST(-
          Title1=VECTOR("Substation"),-
          Title2=VECTOR("Bay"),-
          Title3=VECTOR("Device"),-
          Title4=VECTOR(""),-
          Title5=VECTOR(""),-
          Length1=10,-
          Length2=15,-
          Length3=5,-
          Length4=0,-
          Length5=0,-
          ...

```

The parameters Length1, Length2 and Length3 must now be set as follows:

The Length1 is the definition of the *Substation name* (minimum length is 2), Length2 is the definition of *Bay name* (minimum length is 2) and Length3 is the definition of the *Device (Object) name*. For Length1 and Length2 one character is used for space (between *Station name/Bay name* and *Bay name/Device name*). Length4 and Length5 are optional, but total length of OI attribute must not exceed 63, however 30 characters is recommended for e.g. Event list, Alarm list and printer.

It is of **greatest importance** that this is made before configuration of the installed functions because the configuration process takes these values in account when creating the process database. If variable @OI_LENGTH is not defined in the configuration file, then override value defined in standard function configuration file is valid, which means LENGTH1=2, LENGTH2=14 and LENGTH3=14. This may cause unexpected behavior in run-time, especially in the case where medium voltage and high voltage functions are installed in the same station picture.

For the event list, it can be configured if 'Station_name', 'Bay_name' and 'Device_name' shall be shown (in the 'Object-ID' column of the event list). This is configured using the "Settings" tool (available under the 'Options' menu). Select 'Tools' and 'Show Object ID'. In the appearing dialog it is possible to configure if the 'Station_name', 'Bay_name' and 'Device_name' shall be shown in the event list.

3.3

Installing and configuring

The installation of standard functions is divided into two main parts: installation and configuration.

During the installation, name of the picture function (5 to 10 characters) is required from the user, as well as the position of the picture function in the base picture. Choice of the name and the position is free.

During the configuration, change of the default settings may be done. Process objects are created via the Process Object Tool. An advantage with this procedure is that several picture functions can be installed at once, without leaving the installation tool, and bring up the SCT afterwards for adjustment of configurable parameters and creation of the process objects.

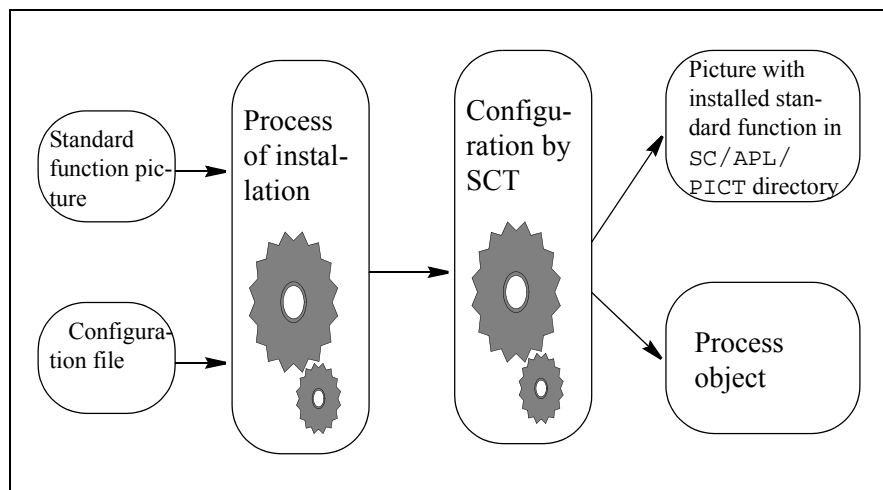

Fig. 2.2 Process of the installation and configuration.

LIB520 standard function pictures are stored in directory `SC\LIB4\SMOD\HVPROCESS\INST`. The following guidelines assumes that you have the base function properly installed in the picture.

3.3.1

Installation tool

For installation of LIB520 standard function in the base picture, the Standard Installation Tool is used. By means of this tool it is possible to choose what kind of function to install and assign an ID, i.e. a unique name for the picture function before it is installed in the picture.

To install a new function, open the picture editor and select a picture. In the picture editor standard tool select Installation Tool. The installation tool will appear. In the directory structure, select Standard Functions/LIB4 and LIB520 and after that HV Process/Voltage Ctrl to bring up the HV/Voltage Control function. Mark the desired function, give an ID and press Install. Position the function anywhere within the base picture.

To install HV/Voltage Control measurement function select Measurement under Voltage Ctrl, give an ID and press Install. Position the function close to HV/Voltage Control function.

3.3.2 Standard Configuration Tool

After installing the standard function in the picture, it is necessary to configure the function. For this purpose, the SCT is used. The user can adjust the configurable parameters and create the process objects.

SCT is accessible via standard picture editor. More information about installing and configuration of each function is given later in the document.

3.3.3 Process Object Tool

From the SCT, the process object tool can be accessed by pushing of the button "Tools". This tool is used for creating all necessary process objects in the data base. The process object tool is only accessible when the installed function needs a process database.

This tools gives automatically suggestion for logical name and value of OI attribute.

3.3.4 Representation Tool

The representation tool is also accessible from the SCT, by pushing of the button "Tools". This tool is used whenever a representation need to be selected or modified, which means that the tool is not visible for all functions, but just for those ones that have possibility of changing of presentation symbol.

3.3.5

Color Tool

The color tool is also accessible from the SCT, by pushing of the button “Tools”. This tool is used if a different color scheme, than that presented in “General principles” on page 31 is desired.

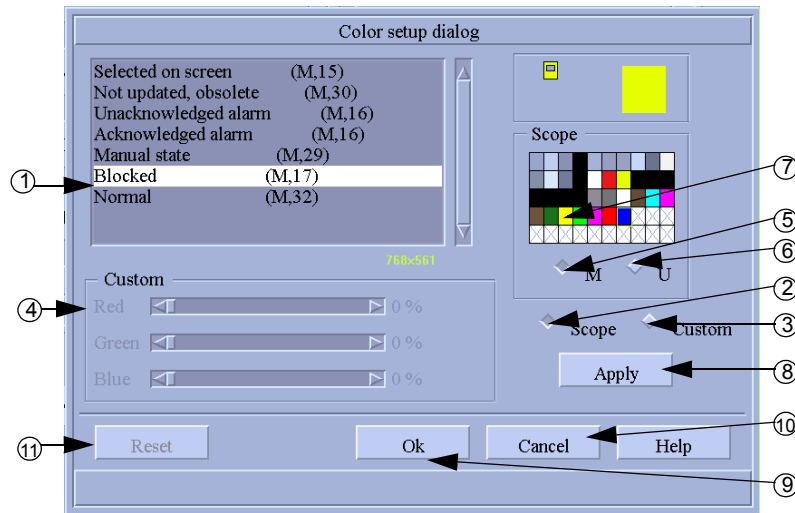

Fig. 2.3 The color tool

To change a color: First select the status, which you want to give a new color (1). Then you select Scope (2), for using a standard color, or Custom (3) to mix your own color using the RGB-mixer (4). If Scope (2) is chosen you shall select either M=System colors (5) or U=User colors (6) and then click on the desired color (7). These colors are defined in the MicroSCADA standard color setting picture. Finally click Apply (8) to effectuate the change or Ok (9) to effectuate and close the dialog. The dialog can, at any time, be cancelled (10) or the colors reset to original (11).

3.3.6

The HV/Voltage Control function

In the installation tool, choose LIB4/LIB520/HVPROCESS/Voltage Ctrl/Large(3*3). With LARGE(3*3) highlighted, enter an ID for the function and press install. Place the picture function somewhere in the picture.

Bring up the SCT to alter the configurables.

Configurable	Choices
STATION_NAME	Text string defining the station name. Max length is defined in the APL:BSV15 variable, see “Creating and preparing an application” on page -16. Default is “”.
BAY_NAME	Text string defining the bay name. Max length is defined in the APL:BSV15 variable, see “Creating and preparing an application” on page -16. Default is “”.
DEVICE_NAME	Text string defining the device name. Max length is defined in

the APL:BSV15 variable, see “Creating and preparing an application” on page -16. Default is “”.

NOMINAL_VOLTAGE	Is the nominal voltage in kV. Default value is 20kV.
MIN_POSITION	Is the min position of the nominal voltage. Default is 0.
MAX_POSITION	Is the max position of the nominal voltage. Default is 19.
NO_TAP_POSITION_AVAILABLE	Check this in the rare occasion when “POSTYPE” (on the VCTR-block in the RET) is set to 0 – “Ignore pos ind (TCPOS)”. Default is “False”.
P_OBJECT_LN	The logical name of the data base process objects. Default is “DUMMY”.
TRANSFORMER_TYPE	The number of winding in the transformer. Default is “2-winding”.
VCTR_TYPE	Type of Voltage Control element used in terminal, SINGLE or PARALLEL. Default value is “SINGLE”. The PARALLEL element can also work for SINGLE mode, but SINGLE element can only work in SINGLE mode. Two alternatives of parallel type exist, one for max 4 transformers and one for max 8 transformers. “PARALLEL4” option tells the parallel info dialog to show parallel grouping between max 4 transformers. “PARALLEL8” option tells the parallel info dialog to show parallel grouping between max 8 transformers.
PRIMARY_POSITION	The direction of the transformers primary winding. Default is “Up”.
STATION_TYPE	Communication unit software, SPANET or LON. Default value is “LON”.
DIALOG_WINDOW_NAME	Defines what shall be presented as object identifier in the main dialog. Default value is “MNOOPER”.
AUTHORIZATION_GROUP	Is the authorization group to which the HV/Voltage Control is connected. Default is “General”.

TOPO_OBJECT_COLOR_HIGH_LN

The LN attribute of first connecting line picture function (line segment) process object. This attribute can be omitted if busbar coloring is not used. Default is “T”.

TOPO_OBJECT_COLOR_NR

The color of the secondary side busbar. This attribute is used by the busbar coloring. This attribute is available when 2-winding transformer is selected. Default is “36”.

TOPO_OBJECT1_COLOR_NR

The color of the secondary side busbar. This attribute is used by the busbar coloring. This attribute is available when 3-winding transformer is selected. Default is “36”.

TOPO_OBJECT2_COLOR_NR

The color of the secondary side busbar. This attribute is used by the busbar coloring. This attribute is available when 3-winding transformer is selected. Default is “36”.

EVENT_BLOCK

Is the corresponding event block in the terminal where the signals are connected to. Possible selections are:

- * Not defined
 - * EV9 for Binary Input, Terminal version 2.3 (for this alt. also EV11 and EV12 is used)
 - * EV10 for Binary Input, Terminal version 2.1 (for this alt. also EV11 and EV12 is used)
- Default value is “Not defined”.

The selected EVENT BLOCK number is the base for calculating the address (OA attribute) for the process objects.

The configurable STATION NUMBER is related to this configurable in that way, if the EVENT BLOCK is changed from default “Not defined” the STATION NUMBER an appropriate number.

COMMAND_BLOCK

Is the corresponding event block in the terminal where the output signals are connected to. Possible selections are:

- * Not defined
- * CM01-CM20

Default value is “Not defined”.

The selected COMMAND BLOCK number is the base for calculating the address (OA attribute) for the process objects.

The configurable STATION NUMBER is related to this configurable in that way, if the COMMAND BLOCK is changed

from default “Not defined” the STATION NUMBER an appropriate number.

NO_PRIORITY This switch tells the Process Object Tool to put the HV/Voltage Control in priority mode or not. Default is FALSE (PRIORITY).

SYMBOL_WITH_BUTTON This switch tells the picture to show the picture symbol or not. Default is TRUE (show the symbol)

SET_SWITCH_STATE_TO_AUTO This switch tells the Process Object Tool to set the objects updating to AUTO. Default is FALSE (MANUAL state). It is only meaningful if the STATION NUMBER, EVENT-/COMMAND BLOCK is set.

STATION_NUMBER Any number between 0 and 2000. Default value is 0. This number is the UN attribute of the process objects. If the base system configuration is missing the STA object equal to this number or having the wrong station type, the installation process will either create or alter this STA definition. This base system update will only be valid until the next system restart. This action is prompted during the installation. The configurable EVENT BLOCK is related to this configurable in that way, if the STATION NUMBER is changed from default 0 the EVENT BLOCK should have a selection earlier not used within the STATION NUMBER.

For the version of 8.4.3 of MicroSCADA the STATION_NUMBER has callback function. STATION_NUMBER must be set before EVENT_BLOCK and COMMAND_BLOCK, otherwise those are dimmed.

TERMINAL_VERSION The terminal version. Default is “2.3”.

Select object tool and create the process object. Press Create All and then Close. Before leaving the SCT, remember to save your changes by choosing OK or Apply.

3.3.6.1

Installation process

The process database is updated with the process objects, ' P_OBJECT_LN' :P, created for the voltage control function(s) that has been installed and configured.

Scale 1_1 : X is created (modified if it exist) if it does not exist. This scale is demanded for the analogue objects of this function.

The command procedure SPU_UPDATE : C is created (modified if it exist). It is used for force up the data form the terminal when update deblock is performed.

Finally the datalog object `A_HTIMEOUT : D` is created (if it does not exist). This object is used for dialog timeout of all HV/Voltage Control functions.

3.3.6.2

Delete process

When a HV/Voltage Control function is deleted, the process database is updated by the deletion of process objects, `' P_OBJECT_LN' : P.`

3.3.7

Voltage control measurements

Measurements are optionally installed, and can only be used when the HV/Voltage Control function is installed because it uses the HV/Voltage Control function database. Install a HV/Voltage Control function first and then the measurement to that function. If it is several HV/Voltage Control functions that should be installed, install always the measurement function direct after the HV/Voltage Control function that the measurement function should be connected to. It is possible to use several measurements to one HV/Voltage Control function, then you can separate the values in the window. Measurements should not be installed if not needed.

In the installation tool, choose LIB4/LIB520/HVPROCESS/Voltage Ctrl/Measurement. With Measurement highlighted, enter an ID for the function and press install. Place the picture function somewhere close to the HV/Voltage Control in the picture.

Bring up the SCT to alter the configurables.

Configurable	Choices
CONNECTED_TO_OBJECT	The picture function name of the HV/Voltage Control function which the Measurement function is connected to. Max length is 10 characters and default is "".
SHOW_VALUES	Configurable which sets the default state of show/hide values at picture presentation. Toggling between show/hide is made from the main dialog of the HV/Voltage Control function. Notice that the toggle is returning back to default when leave and enter again the process picture. TRUE or FALSE, default is TRUE. (If no values want to be shown this function should not be installed.)
SHOW_SET_POINT_VALUE	Decides if SET_POINT_VALUE is to be shown. Selection is not toggable in run-time. TRUE or FALSE, default is TRUE.
SHOW_TAP_POSITION	Decides if TAP_POSITION is to be shown. Selection is not toggable in run-time. TRUE or FALSE, default is TRUE.
SHOW_OPERATOR_PLACE	

Decides if OPERATOR_PLACE is to be shown. Selection is not toggable in run-time.
TRUE or FALSE, default is TRUE.

SHOW_CONTROL_MODE

Decides if CONTROL_MODE is to be shown. Selection is not toggable in run-time.
TRUE or FALSE, default is TRUE.

SHOW_OPERATION_MODE

Decides if OPERATION_MODE is to be shown. Selection is not toggable in run-time.
TRUE or FALSE, default is TRUE.

Before leaving the SCT, remember to save your changes by choosing OK or Apply.

3.3.7.1

Installation process

Measurements uses the HV/Voltage Control function database.

3.3.7.2

Delete process

Measurements use the HV/Voltage Control function database.

3.4

Additional application engineering

3.4.1

Switch state

Immediately after installation, all process objects will have the switch state set to manual state ($SS = 1$), except process object with $IX = 243$ which is internal process object and should always be updated automatically. Before commissioning, some process objects must be set to auto state ($SS = 2$). Until this is done, "Not connected to process" will be visible on the status bar in the Main dialog. See "Process objects" on page 57. regarding what process objects that has to be set to $SS=2$.

3.4.2

Addressing the process objects

Before the installed functions can communicate with the process, it is necessary to put addresses to all process objects that have the switch state set to auto.

3.4.3

Remaining tasks

Before commissioning you have to:

-
- 1 address the transformer protection unit.**
 - 2 configure the base system for communication with transformer protection terminal.**
 - 3 configure LON HW and SW.**
 - 4 create and address process objects for signals that are not covered within the scope of HV/Voltage Control standard functions.**

The chapter “Technical descriptions”

Overview of the standard functions	29
HV/Voltage Control	29
Description	29
Target systems	29
Communication support	29
Features	30
Process commands	30
HV/Voltage Control measurements	30
Description	30
Tutorial	31
General principles	31
Color coding	31
Color definitions	32
Attribute expressions for color definitions	32
Selection	33
Indications	33
Representation file	34
HV/Voltage Control	34
General functionality	34
History registrations	34
Blockings	35
System start-up	35
Process commands	35
Internal (MicroSCADA) commands	35
Fictitious commands	36
Graphical representation	36
Process presentation	36
Dialog structure	37
Main Dialog	38
Acknowledge alarms	41
Adjust setpoint voltage	42
Block activation	43
Blockings	44
Blocking status	47
Maintenance	49
Operation information	50
Parallel info	52
HV/Voltage Control status	53
HV/Voltage Control measurements	54
General functionality	54
Graphical representation	54
Process presentation	54

1 Overview of the standard functions

The functions are designed to be as general as possible. This will make special configurations and customer demands much easier to fulfil for the application engineer. The number of versions of each function should be kept to a minimum.

The following functions are included in the HVLib:

SPI_TRANSB,

HV/Voltage Control with semigraphic size 3x3 (SPI_TRANSB). Full voltage control for power transformers in RET521.

SPI_TRANSX,

HV/Voltage Control measurement to install together with SPI_TRANSB. A window to show some values from the Voltage Control function.

1.1 HV/Voltage Control



Fig. 1 HV/Voltage Control symbol

Function name: SPI_TRANSB.PIC

File location in package: HVPROCESS\INST

1.1.1 Description

This function is used for:

- Monitoring and controlling the voltage on the secondary side of the power transformer.

1.1.2 Target systems

- RET 521

1.1.3 Communication support

- LON and SPA

1.1.4**Features**

- Blocking/Deblocking of alarms, events, printout, update and remote events & indications
- Acknowledge alarms
- Help in all dialogs
- Change operation mode
- Change control mode
- Show regulation mode
- Show different control voltage
- Change the voltage control
- Load voltage adjustment
- Block activation
- Show blocking status
- Maintenance information
- Operation information
- Parallel blocking info

1.1.5**Process commands**

Following process commands can be performed:

- Adjustment the voltage of the power transformer

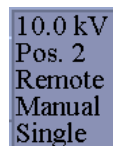
1.2**HV/Voltage Control measurements**

10.0 kV
Pos. 2
Remote
Manual
Single

Fig. 2 HV/Voltage Control measurement symbol

Function name: SPI_TRANSX.PIC
File location in package: HVPROCESS\INST

1.2.0.1**Description**

The measurements should not be considered as a true function, in comparison with functions such as voltage control, protections functions etc. Its purpose is to gather and in a short form display measurements made by the VCTR function, and some of its status information.

Measurements can only be used together with the HV/Voltage Control function because it uses the HV/Voltage Control function database. It is possible to show five values, Present Setpoint, Position of the tap changer, Operation mode, Control mode and Regulation mode and it is possible to present them in several windows that are connected to the same HV/Voltage Control function.

2 Tutorial

In this chapter the functionality of the standard functions is described. After general principles, the HV/Voltage Control function is described in detail.

2.1 General principles

Some principles are general (colors etc.). A description of these general principles follows below.

2.1.1 Color coding

The color coding below is applied generally. The colors are stated in priority order, e.g. red takes precedence over yellow.

Color	Description
White flashing	Selected object under command
White	Selected on the MicroSCADA screen
Magenta	Not updated, obsolete value, not in use or not sampled
Red flashing	Unacknowledged alarm
Red	Acknowledged alarm or faulty state
Cyan	Update blocked or manually entered
Yellow	Warning or blockings (alarms, events, printouts)
Brown	Control blocked
Green	Normal state

2.1.2

Color definitions

The table below gives definition of colors used for presentation of process symbols and symbols in object picture.

Table 1: Color definitions used in HV/Voltage Control

Name	Color definition
White	("M",27)
Magenta	("M",30)
Red	("M",16)
Yellow	("M",17)
Cyan	("M",29)
Brown	("M",28)
Green	("M",32)
Black	("M",14)

2.1.3

Attribute expressions for color definitions

The following expressions and attributes are used to calculate the color. See the section for each standard function, what indexes are used.

Table 2: Attributes expressions for color presentation

Description	Attribute used	Color	Comment
Selected object under command	BI	White flashing	
Selected on the MicroSCADA screen	-	White	The variable <code>\CALL_ID' :VARMED</code> is used
Not sampled	OS = 10	Magenta	No value is presented

Table 2: Attributes expressions for color presentation

Description	Attribute used	Color	Comment
Obsolete value	OS = 1-9	Magenta	Last known value is presented
Unacknowledged alarm	AR = 0	Red flashing	-
Acknowledged alarm	AL = 1	Red	-
Update blocked	BI	Cyan	-
Manual state	SS = 1	Cyan	-
Alarms blocked	AB = 1	Yellow	Only for indexes with position 27 of RX attribute <> "X"
Events blocked	HB = 1	Yellow	Only for indexes with position 27 of RX attribute <> "X"
Printout blocked	PB = 1	Yellow	Only for indexes with position 27 of RX attribute <> "X"
Remote events and indications blocked	XB = 1	Yellow	Only for indexes with position 27 of RX attribute <> "X"
Control blocked	BI	Brown	

2.1.4**Selection**

Selectable objects have "raised" areas according to Motif standard. There are no "hidden" functions.

Note that selectable is not the same as controllable. Pressing on a selectable object will bring up the main dialog, from which other actions can be initiated.

Only one object can be selected per MicroSCADA screen. The selection of another one will automatically cancel the previous selection.

2.1.5**Indications**

The indications are only used for monitoring and no actions.

The indications are presented in index order starting from the lowest index. The symbols are always square shape. Text describing symbol is fetched from data base OX attribute for the index.

Table 3: Indication symbols

Description	Attribute	OV = 0	OV = 1
In use	IU = 0	None	None
Not sampled	OS = 10	magenta “?”	magenta “?”
Obsolete value	OS = 1-9	magenta square	magenta filled square
Unacknowledged alarm	AR = 0	flashing red square	flashing filled red square
Acknowledged alarm	AL = 1	red square	red filled square
Manual state	SS = 1	cyan square	cyan filled square
Active blocking	HB or AB or PB or XB = 1	yellow square	yellow filled square
Normal state	otherwise	green square	green filled square

Representation symbols used for all indications are stored in the representation SR_OBPIC in representation file SMOD\HVPROCESS\USE\SR_LIBFGH.PIR.

2.1.6

Representation file

All representation symbols are stored in S_USE\SR_LIBFGH.PIR file, where S_USE is logical path as it is defined in PATH4_S1.TXT file. For HV/Voltage Control function an overview of used representations will be given separately. Standard color definition used for presentation of symbols are given in “Color definitions used in HV/Voltage Control” on page 32.

2.2

HV/Voltage Control

Below is a description of the functionality of the HV/Voltage Control.

2.2.1

General functionality

In this section a more general description of the functionality and performance is described.

2.2.1.1

History registrations

Always when the process objects 1..71 passes and alarm or warning limit, provided that no blocking is prevailing. Events are also generated when blocking (index 240..245) is performed.

2.2.1.2**Blockings**

Process signals can be blocked from the blockings dialog (events, alarms, printout update or remote events and indications). Other control system signals (internal signals) are not blocked by this facility.

2.2.1.3**System start-up**

The process objects (index 1..71) are updated at system start up.

2.2.1.4**Process commands**

Process commands can be issued for:

- Change the tap position
- Change control mode
- Change operation mode
- Adjust setpoint voltage with factor 1 to 4
- Block activation

Authority level 1 or greater is required in order to issue the above commands.

Below is a list of values to be issued for the different commands.

Table 4: HV/Voltage Control Commands (Process object 210)

Order	Bit	Value
Set Manual	0.	OV==1,
Set Auto	1.	OV==2,
Raise	2.	OV==4,
Lower	3.	OV==8,
Set Remote	4.	OV==16,
Set Station	5.	OV==32,
LVA Reset	6.	OV==64,
	7.	OV==128,
TotBlk_On	8.	OV==256,
AutoBlk_On	9.	OV==512,
TotBlk_Off	10.	OV==1024,
AutoBlk_Off	11.	OV==2048,
LV1	12.	OV==4096,
LV2	13.	OV==8192,
LV3	14.	OV==16384,
LV4	15.	OV==32768

2.2.1.5**Internal (MicroSCADA) commands**

Internal (MicroSCADA) commands can be issued for:

- Block/Deblock Alarms
- Block/Deblock Events
- Block/Deblock Printouts
- Block/Deblock Update
- Block/Deblock Remote events and indications

Authority level 1 or greater is required in order to issue the above commands.

2.2.1.6 Fictitious commands

Fictitious commands can be issued for editing alarm and warning limits.

2.2.2 Graphical representation

In this section details about the presentation, actions and conditions for the process picture are described.

2.2.2.1 Process presentation

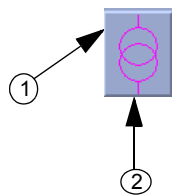

Fig. 3 Process representation for HV/Voltage Control.

The following information is displayed in the process picture:

- HV/Voltage Control status as summary color information (alarms, blockings etc.)

The presentation below is, for each item, given in priority order. E.g. an alarm will always be shown before a blocking.

Table 5: Process picture representation for HV/Voltage Control

Description	Presentation	Color	Expression
1. Select area	Unset Function key. (Not selected)	According to the color definition for push buttons.	'ID' : VARMED = FALSE
	Set Function key. (Selected)	According to the color definition for the push button.	'ID' : VARMED = TRUE
2. Status	symbol	2)	2)

2) See “Color definitions used in HV/Voltage Control” on page 32. All objects of the standard function (which are in use) are used to express the proper color definition.

‘ID’ is the ID given during installation of the picture function, ‘LN’ is the logical name of the process objects.

The following actions can be performed from the process presentation:

Table 6: Actions possible from process presentation

Function	Condition(s)	Action
1. Selection	-	Present main dialog

2.2.3

Dialog structure

In this section details about the presentation, actions and conditions for the dialogs are described.

The dialog structure is as follows:

Main Dialog

Control Mode (Manual or Automatic)

Operation Mode (Remote, Station, Station and Remote (No_Priority))

Manual control (Lower or Raise)

More button

Ack. Alarms

Adjust load voltage

Blockings (Block activation, Blockings, Blocking status)

Maintenance

Operation info

Parallel info

Close push button

Help button

2.2.3.1

Main Dialog

The Main dialog is displayed after clicking on the HV/Voltage Control function key.

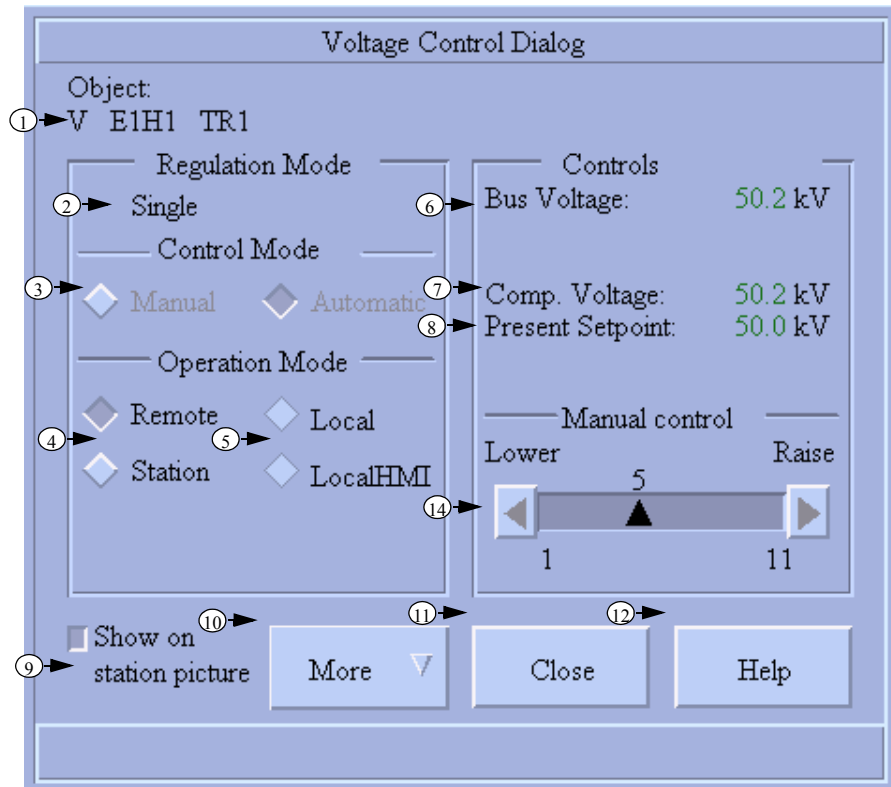

Fig. 4 Main dialog for HV/Voltage Control, priority mode

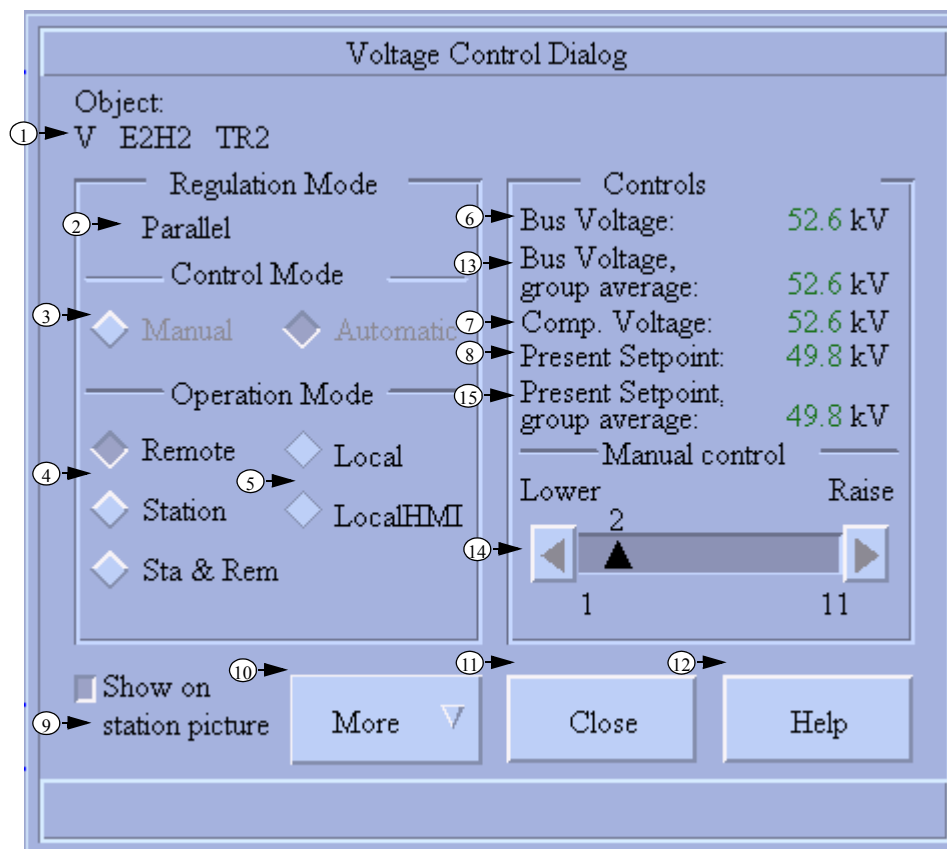

Fig. 5 Main dialog for HV/Voltage Control, no priority mode

The following table lists values presented in the main dialog. The descriptions are numbered as shown in the main dialog figures.

Table 7: Voltage Control Dialog representation

Description	Presentation	Color	Expression
1. Object name in textual form, logical name of station and bay			
2. Regulation Mode	Single, Parallel, Parallel/Adapt	Black	'LN' ¹ : P37-39
5. Operation Mode	Local, LocalHMI		'LN' : P33-34
6. Bus Voltage	Value	2	'LN' : P11
13. Bus Voltage, group average ³	Value	2	'LN' : P3
7. Comp. Voltage	Value	2	'LN' : P13
8. Present Setpoint	Value	2	'LN' : P14
15. Present Setpoint, group average ³	Value	2	'LN' : P4

1. 'LN' is the logical name of the process objects for the HV/Voltage Control function.
2. See "Color definitions used in HV/Voltage Control" on page 32. All objects of the standard function (which are in use) are used to express the proper color definition.
3. Number 13 and 15 are only shown if it is in parallel configuration mode and if operation PAR and OperUsetParl is put to ON.

The following actions can be performed from the main dialog, numbered as shown in the main dialog figures:

Table 8: Actions possible in the Main dialog

Function	Condition(s)	Action
Move	-	Move the dialog to a new position
3. Control Mode	Operation Mode= Station	Change the Control Mode to Manual or Automatic mode
4. Operation Mode	Not Local or Local HMI for priority mode Not Local HMI for no priority mode	Change the Operation mode to Station or Remote. For no priority mode also to Station and Remote.
14. Manual Control	Operation Mode=Station and Control Mode= Manual	Change the position of the tap changer
9. Show on station picture	Show_values is set in the configurable attributes	Show/Hide the measurement function (if this is used)
11. Close	-	Close the main control window
12. Help	-	Open help window
10. More Button	-	Possible to select other dialogs
Acknowledge alarms (MORE BUTTON)	Authority level >= 1	Display acknowledge alarm picture
Adjust load voltage (MORE BUTTON)	-	Bring up adjust load voltage dialog
Block activation (MORE BUTTON)	-	Bring up block activation dialog
Blockings (MORE BUTTON)	-	Bring up blockings dialog
Blocking status (MORE BUTTON)	-	Bring up blocking status dialog
Maintenance (MORE BUTTON)	-	Bring up maintenance dialog

Table 8: Actions possible in the Main dialog

Function	Condition(s)	Action
Operation info (MORE BUTTON)	-	Bring up operation info dialog
Parallel info (MORE BUTTON)	Regulation Mode <> Single	Bring up parallel info dialog

If no action is performed within a certain timeout, then the dialog window, with exception of object picture, is closed. The dialog windows are also closed if any other function is selected on the MicroSCADA screen.

2.2.3.2

Acknowledge alarms

All alarms can be acknowledged per object. This option is accessible from the main dialogs “More” button after choosing of the option “Ack.alarms...”.

Text message that appears depends on if active alarms exists or not for the selected object. This picture is not movable separately, but always follows Main dialog.

However, all alarms are always included in the alarm list accessible on menu bar in the base picture. In this list, alarms can be acknowledged on selective way per active alarm, or all active alarms at the time.

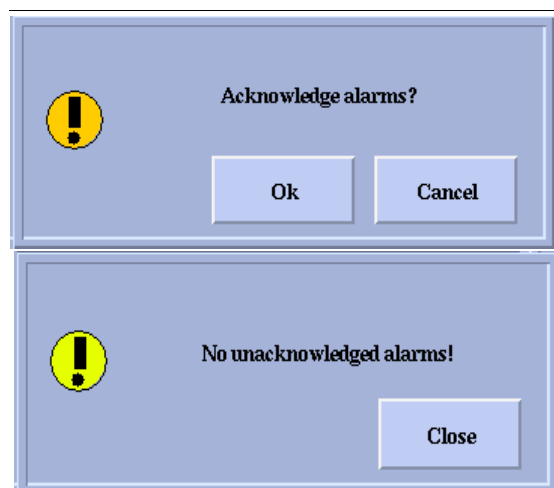

Fig. 6 Acknowledge alarms dialogs

2.2.3.3

Adjust setpoint voltage

The following information is displayed in the Adjust setpoint voltage dialog:

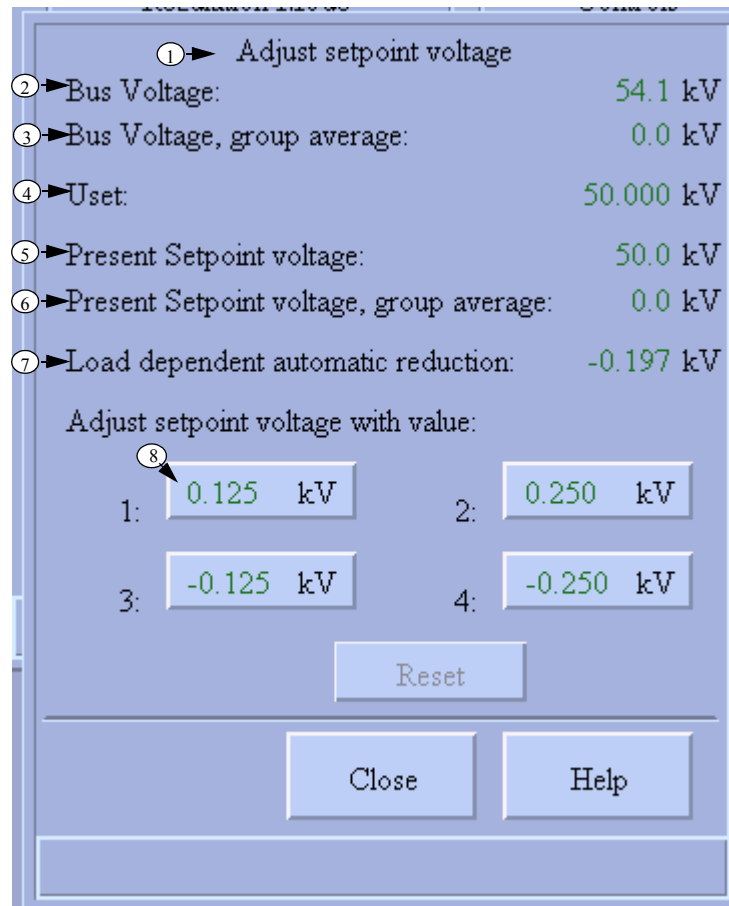

Fig. 7 Adjust setpoint voltage dialog for HV/Voltage Control.

The following table lists the data presented, numbered as in the above figure.

Table 9: Adjust setpoint voltage presentation

Description	Presentation	Color	Expression
1. Title bar			
2. BUS VOLTAGE	Value	2	'LN' ¹ : P11
3. BUS VOLTAGE, group average	Value	2	'LN' : P3
4. USET	Value	2	'LN' : P12
5. PRESENT SET-POINT	Value	2	'LN' : P14
6. PRESENT SET-POINT, group average	Value		'LN' : P4
7. VRAUTO	Value	2	'LN' : P26
8. LVCONST1 - 4	Value	2	'LN' : P27-30

1. 'LN' is the logical name of the process objects for the HV/Voltage Control function.

2. See "Color definitions used in HV/Voltage Control" on page 32. All objects of the standard function (which are in use) are used to express the proper color definition.

The following actions can be performed from the Adjust setpoint voltage dialog:

Table 10: Actions possible in the Adjust setpoint voltage dialog

Function	Condition(s)	Action
RESET	-	Reset activated factor
LV1 - LV4	-	Activation of factor 1 - 4
Close	-	Erase the object picture
Help	-	Display help viewer with help about the object picture

If no action is performed within a certain timeout, then the dialogs are erased. The dialogs are also erased if any other function is selected in the process picture.

2.2.3.4

Block activation

The following information is displayed in the Block activation dialog:

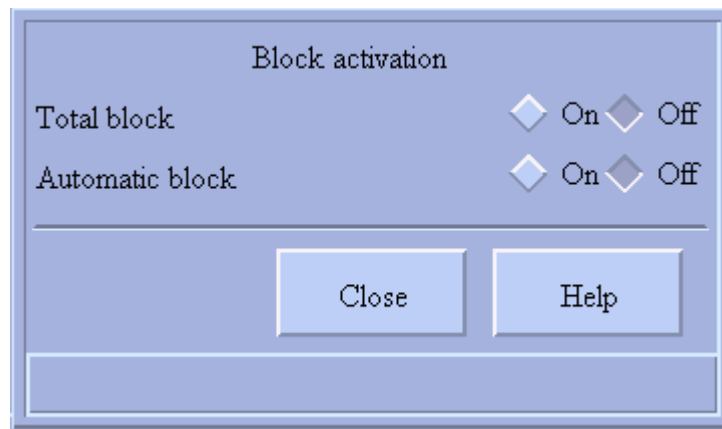

Fig. 8 Block activation dialog for HV/Voltage Control.

The following actions can be performed from the Block activation dialog:

Table 11: Actions possible in the Block activation dialog

Function	Condition(s)	Action
TOTBLK	-	Total blocking On/Off
AUTOBLK	-	Auto mode blocking On/Off
Close	-	Erase the object picture
Help	-	Display help viewer with help about the object picture

If no action is performed within a certain timeout, then the dialogs (except the object picture) are erased. The dialogs are also erased if any other function is selected in the process picture.

2.2.3.5

Blockings

Signals coming from the process can be blocked for five different purposes:

- Event blockings
- Alarm blockings
- Printout blockings
- Update blockings
- Remote events and indications

Blockings can be made from each function. The blocking is made by setting of the corresponding process object attribute HB (event block), AB (alarm block), PB (printout block), UB (Update block) or XB (activation block - for remote events and indications). This means that these blockings are internal in the MicroSCADA. UB causes the values to be obsolete (Magenta), deblock will return the color to green.

Blocking function is executed by retrieval of the whole database. Condition for blocking is the OI attribute. Note thus that it is very important to configure the OI attribute correctly in order to have the blocking function to work. See “Object identifier” on page 17..

Blocking and deblocking can be performed from the blocking dialog that is reached from the main menu by pushing drop-down button “More” and then selecting of “Blockings >”, “Blockings...”. Blocking dialog is placed over the Main dialog of the concerning standard function on such way that title and info bar of the Main dialog is used, as well as the process object name.

Blockings are presented in Blocking status dialog according to “Color coding” on page 31.

Following information is displayed in the Blocking dialog:

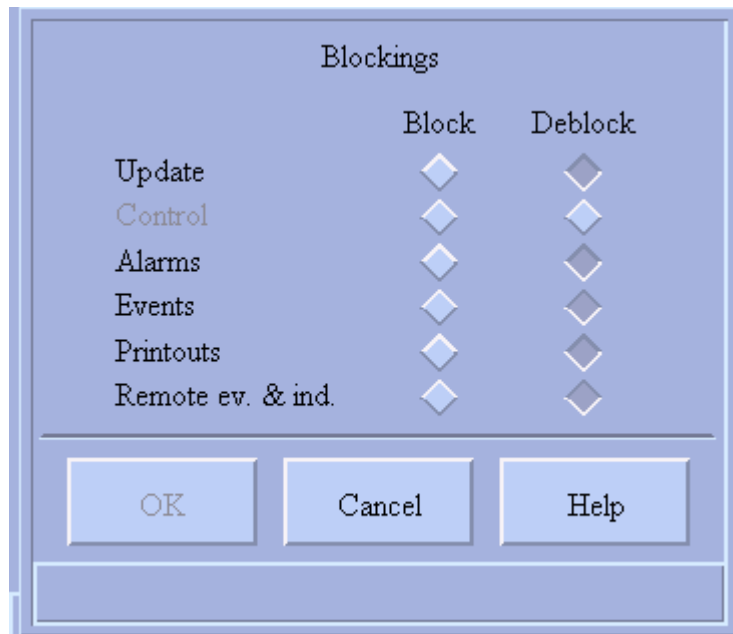

Fig. 9 HV/Voltage Control Blocking dialog

The following actions can be performed from the Blocking dialog:

Table 12: Actions possible in the Blockings dialog

Function	Condition	Action
Move	-	Movement is made by moving the main dialog.
Block events	Authority level ≥ 1	- Set HB=1 for selected objects ¹ - Set index 240 to 1 ¹
Deblock events	Authority level ≥ 1	- Set HB=0 for selected objects ¹ - Set index 240 to 0 ¹
Block alarms	Authority level ≥ 1	- Set AB=1 for selected objects ¹ - Set index 241 to 1 ¹
Deblock alarms	Authority level ≥ 1	- Set AB=0 for selected objects ¹ - Set index 241 to 0 ¹
Block printout	Authority level ≥ 1	- Set PB=1 for selected objects ¹ - Set index 242 to 1 ¹
Deblock printout	Authority level ≥ 1	- Set PB=0 for selected objects ¹ - Set index 242 to 0 ¹
Block update	Authority level ≥ 1	- Set UB=1 for selected objects ¹ - Set index 245 to 1 ¹
Deblock update	Authority level ≥ 1	- Set UB=0 for selected objects ¹ - Set index 245 to 0 and trig SPU_UPDATE:C. ¹
Block Remote events and indications	Authority level ≥ 1	- Set XB=1 for selected objects ¹ - Set index 244 to 1 ¹
Deblock Remote events and indications	Authority level ≥ 1	- Set XB=0 for selected objects ¹ - Set index 244 to 0 ¹
OK	Authority level ≥ 1	Execute the blocking actions according to what is set by the buttons explained above. Return to the main dialog
Cancel	-	Erase the Blocking dialog and return to the main dialog, without changing the limits.
Help	-	Display help viewer with help about the HV/Voltage Control blocking dialog

1. No action is performed until the 'OK' button is pressed.

Blocking and deblocking require authority level ≥ 1 (Operator authority). If blocking or deblocking is not permitted, the function key is dimmed.

If no action is performed within a certain timeout, then the dialogs (except the object picture) are erased. The dialogs are also erased if any other function is selected in the process picture.

2.2.3.6

Blocking status

The following information is displayed in the Blocking status:

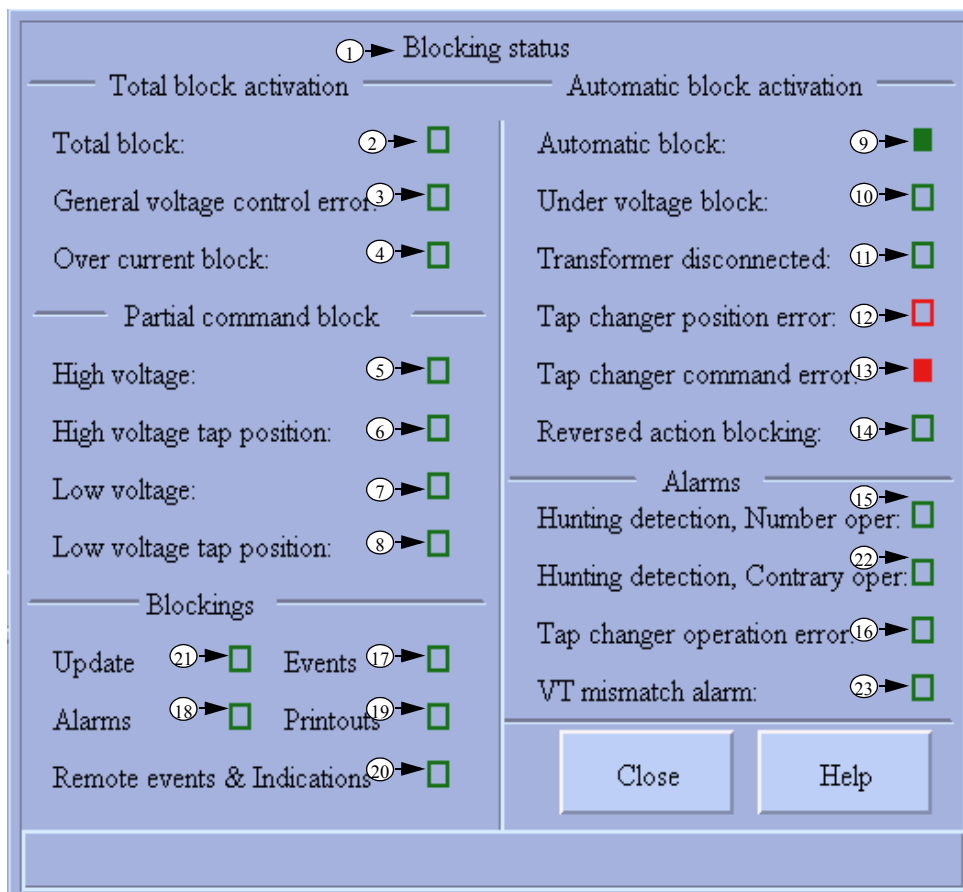

Fig. 10 Blocking status dialog for HV/Voltage Control.

The following table lists the data presented, numbered as in the figure:

Table 13: Blocking status representation

Description ¹	Presentation	Color	Expression
1. Title bar			
2. TOTBLKD	Value	2	'LN' : P51
3. ERROR	Value	2	'LN' : P40

Table 13: Blocking status representation

Description ¹	Presentation	Color	Expression
4. IBLK	Value	2	'LN' : P53
5. UMAX	Value	2	'LN' : P58
6. HIPOS	Value	2	'LN' : P57
7. UMIN	Value	2	'LN' : P59
8. LOPOS	Value	2	'LN' : P56
9. AUTOBLKD	Value	2	'LN' : P52
10. UBLK	Value	2	'LN' : P54
11. TFODISC	Value	2	'LN' ³ : P60
12. POSERR	Value	2	'LN' : P41
13. CMDERR	Value	2	'LN' : P42
14. REVACBLK	Value	2	'LN' : P55
15. HUNTING	Value	2	'LN' : P45
22. WINHUNT	Value	2	'LN' : P8
16. TCERR	Value	2	'LN' : P43
23. VTALARM	Value	2	'LN' : P9
17. EVENTS	Value	2	'LN' : P240
18. ALARMS	Value	2	'LN' : P241
19. PRINTOUT	Value	2	'LN' : P242
20. REMIND	Value	2	'LN' : P244
21. UPDATE	Value	2	'LN' : P245

1. For an explanation of presentation and colors, see "Indications" on page 33

2. See "Color definitions used in HV/Voltage Control" on page 32. All objects of the standard function (which are in use) are used to express the proper color definition

3. 'LN' is the logical name of the process objects for the HV/Voltage Control function.

The following actions can be performed from the Blocking status dialog:

Table 14: Actions possible in the Blocking status dialog

Function	Condition(s)	Action
Close	-	Erase the object picture
Help	-	Display help viewer with help about the object picture

If no action is performed within a certain timeout, then the dialogs (except the object picture) are erased. The dialogs are also erased if any other function is selected in the process picture.

2.2.3.7

Maintenance

The following information is displayed in the Maintenance dialog:

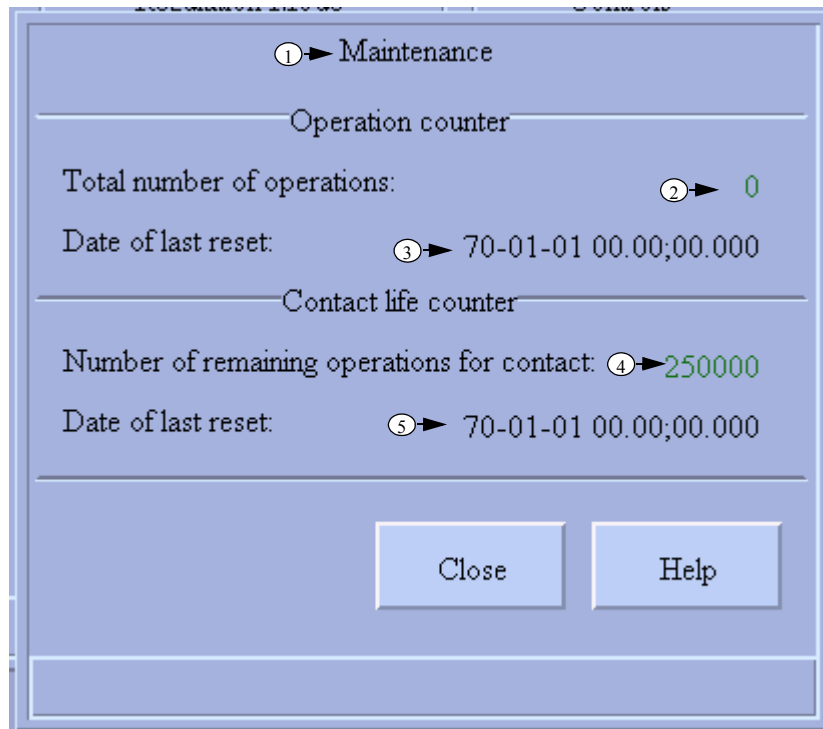

Fig. 11 Maintenance dialog for HV/Voltage Control.

The following table lists the data presented, numbered as in the figure.

Table 15: Maintenance representation

Description	Presentation	Color	Expression
1. Title bar			
2. NOOFOPERATIONS	Value	1	'LN ² ' : P15
3. OPCNTRESETDAT	String	1	'LN' : P61
4. CONTACTLIFE	Value	1	'LN' : P16
5. CLRESETDATE	String	1	'LN' : P62

1. See "Color definitions used in HV/Voltage Control" on page 32. All objects of the standard function (which are in use) are used to express the proper color definition

2. 'LN' is the logical name of the process objects for the HV/Voltage Control function.

The following actions can be performed from the Maintenance dialog:

Table 16: Actions possible in the Maintenance dialog

Function	Condition(s)	Action
Close	-	Erase the object picture
Help	-	Display help viewer with help about the object picture

If no action is performed within a certain timeout, then the dialogs (except the object picture) are erased. The dialogs are also erased if any other function is selected in the process picture.

2.2.3.8

Operation information

The following information is displayed in the Operation information:

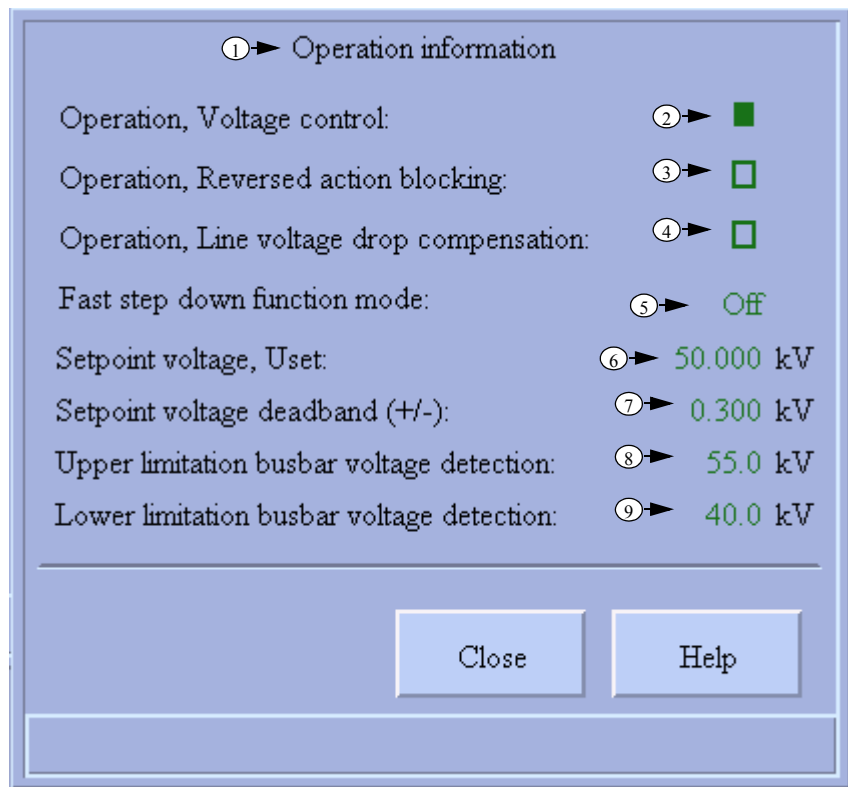

Fig. 12 Operation information dialog for HV/Voltage Control.

The following table lists the data presented, numbered as in the figure.

Table 17: Operation information representation

Description	Presentation	Color	Expression
1. Title bar			
2. OPERATION	1	1	'LN ² ' : P65
3. OPERATIONRA	1	1	'LN' : P66
4. OPERATIONLDC	1	1	'LN' : P67
5. FSDMODE	0=Off 1=Auto 2=Automan	3	'LN' : P68
6. USET	Value	3	'LN' : P12
7. UDEADBAND	Value	3	'LN' : P69
8. ULMAX	Value	3	'LN' : P70
9. ULMIN	Value	3	'LN' : P71

1. See "Indications" on page 33.

2. 'LN' is the logical name of the process objects for the HV/Voltage Control function

3. See "Color definitions used in HV/Voltage Control" on page 32. All objects of the standard function (which are in use) are used to express the proper color definition.

The following actions can be performed from the Operation information dialog:

Table 18: Actions possible in the Operation information dialog

Function	Condition(s)	Action
Close	-	Erase the object picture
Help	-	Display help viewer with help about the object picture

If no action is performed within a certain timeout, then the dialogs (except the object picture) are erased. The dialogs are also erased if any other function is selected in the process picture.

2.2.3.9

Parallel info

The following information is displayed in the Parallel info:

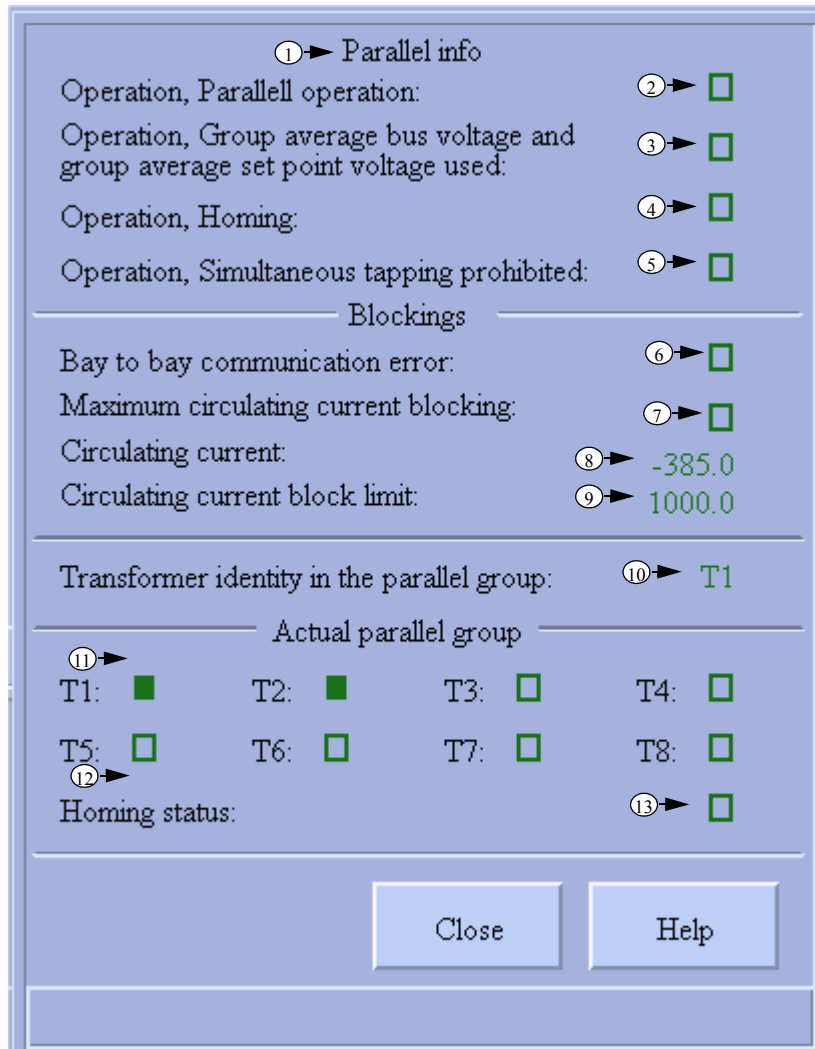

Fig. 13 Parallel info dialog for HV/Voltage Control.

The following table lists the data presented, numbered as in the figure.

Table 19: Parallel info representation

Description	Presentation	Color	Expression
1. Title bar			
2. OPERATION-PAR	1	1	\LN ² :P5

Table 19: Parallel info representation

Description	Presentation	Color	Expression
3. OPERUSET-PAR	1	1	'LN' : P6
4. OPERHOMMING		1	'LN' : P17
5. OPERSIMTAP	1	1	'LN' : P18
6. COMERR	1	1	'LN' : P44
7. ICIRC	1	1	'LN' : P25
8. CIRCCURRENT	Value	3	'LN' : P72
9. CIRCCURLIMIT	Value	3	'LN' : P73
10. TIDENTITY	0=T1, 1=T2 2=T3, 3=T4	3	'LN' : P74
10. TIDENTITY	0=T1, 1=T2, 2=T3, 3=T4, 4=T5, 5=T6, 6=T7, 7=T8	3	'LN' : P74
11. T1PG-T4PG	1	1	'LN' : P21-24
12. T5PG-T8PG ⁴	1	1	'LN' : P46-49
13. HOMING	1	1	'LN' : P19

1. See "Indications" on page 33.

2. 'LN' is the logical name of the process objects for the HV/Voltage Control function.

3. See "Color definitions used in HV/Voltage Control" on page 32. All objects of the standard function (which are in use) are used to express the proper color definition.

4. Only when VCTR_TYPE = PARALLEL8.

The following actions can be performed from the Parallel info dialog:

Table 20: Actions possible in the Parallel info Dialog

Function	Condition(s)	Action
Close	-	Erase the object picture
Help	-	Display help viewer with help about the object picture

If no action is performed within a certain timeout, then the dialogs (except the object picture) are erased. The dialogs are also erased if any other function is selected in the process picture.

2.2.3.10

HV/Voltage Control status

HV/Voltage Control status is presented on the status bar for each dialog. Status messages in falling priority for the apparatus are:

- Not connected to process (see “Process Objects” on page 64)
- Not updated

2.3 HV/Voltage Control measurements

2.3.1 General functionality

Measurements can only be used together with the HV/Voltage Control function because it uses the HV/Voltage Control function database. It is possible to show five values, Present Setpoint, Position of the tap changer, Operation mode, Control mode and Regulation mode and it is possible to present them in several windows that are connected to the same HV/Voltage Control function.

2.3.2 Graphical representation

2.3.2.1 Process presentation

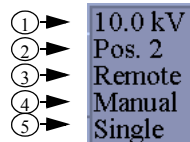

Fig. 14 Process representation for HV/Voltage Control Measurement.

The following table lists the data presented, numbered as in the figure.

Table 21: HV/Voltage Control Measurement representation

Description	Presentation	Color	Expression
1. Present Setpoint	Value	1	'LN ² ' : P14
2. Position of the tap changer	Value	1	'LN' : P10
3. Operation mode	Remote, Station, Local, LocHMI, St/Re/Lo, St/Re, St/Lo, Re/Lo	1	'LN' : P31-34
4. Control Mode	Manual, Auto	1	'LN' : P35-36
5. Regulation Mode	Single, Parallel, Par/Adapt	1	'LN' : P37-39

1. See “Color definitions used in HV/Voltage Control” on page 32. All objects of the standard function (which are in use) are used to express the proper color definition.

2. 'LN' is the logical name of the process objects for the HV/Voltage Control function.

Appendix

Application engineering information	57
Process objects.....	57
Format pictures	57
Dialog pictures	57
Installation files	58
Texts	58
Runtime files	59
Complete file listing	59
Installation files	59
Dialog files	60
Format picture files	61
Run-time command files	61
Run-time text files	61
Installation text files.....	62
Help files	62
Representation files	63
Window representations.....	63
Process Objects	64
Type definitions.....	64
HV/Voltage Control	70
Object list	73
Command procedures	73
Datalog objects	73
Scale objects.....	73
Format pictures and status texts	74
Updated files	75
PATH4_S1.TXT	75
INDEX4_S3.TXT	75

1 Application engineering information

Listed here are all files that are needed during runtime, in order to make a built function operate properly, such as format pictures, dialog pictures, text files and help files.

1.1 Process objects

The process objects related to this function are described in “Process Objects” on page 64.

1.2 Format pictures

Format pictures used during runtime for event and alarm presentation. All pictures are stored in the directory `\sc\Lib4\Smod\HVPROCESS\Use`.

Table 1:

Filename	Name
FORM4S002.PIC	Process blockings
FORM4S003.PIC	Process alarms
FORM4S004.PIC	Process on/off signals (BI)
FORM4S008.PIC	Process analog values
FORM4S013.PIC	Process function orders
FORM4S014.PIC	Process on/off signals (AI)

1.3 Dialog pictures

Files used during runtime in process pictures. All pictures are stored in the directory `\sc\Lib4\Smod\HVPROCESS\Use`.

Table 2:

Filename	Name
SPU_TRANSA.PIC	Main dialog V 2.1
SPU_TRANSB.PIC	Operation info V 2.1
SPU_TRANSC.PIC	Adjust load voltage V 2.1
SPU_TRANSD.PIC	Blockings
SPU_TRANSE.PIC	Blocking status V 2.1
SPU_TRANSF.PIC	Parallel info V 2.1
SPU_TRANSH.PIC	Maintenance
SPU_TRANSK.PIC	Block activation
SPU_TFOA.PIC	Main dialog V 2.3
SPU_TFOB.PIC	Operation info V 2.3
SPU_TFOC.PIC	Adjust load voltage V 2.3

Table 2:

Filename	Name
SPU_TFOE.PIC	Blocking status V 2.3
SPU_TFOF.PIC	Parallel info V 2.3
SPU_TFOF2.PIC	Parallel info V 2.4 (PARALLEL8)

1.4**Installation files**

Files used during installation and configuration of the function. All files are stored in the directory \sc\Lib4\Smod\HVPROCESS\Inst.

Table 3:

Filename	Name
SPI_TRANS.DAT	Standard configuration data file
SPI_TRANSB.PIC	Picture function file
SPI_TRANSX.DAT	Standard configuration data file for measurement window
SPI_TRANSX.PIC	Picture function file for measurement window

1.5**Texts**

Text files which are language dependable used during installation/configuration and runtime. All files are stored in the directory \sc\Lib4\Smod\HVPROCESS\Langn, where *n* is a number expressing the used language. Normally, Lang0 is used, where 0 means english.

Table 4:

Filename	Name
SPU_TRANSA.HLP	Main dialog help texts V 2.1
SPU_TRANSB.HLP	Operation info dialog help text
SPU_TRANSC.HLP	Adjust load voltage dialog help texts V 2.1
SPU_TRANSD.HLP	Blockings dialog help texts
SPU_TRANSE.HLP	Blocking status dialog help texts
SPU_TRANSF.HLP	Parallel info dialog help text V 2.1
SPU_TRANSH.HLP	Maintenance dialog help texts
SPU_TRANSK.HLP	Block activation dialog help texts
SPU_TRANSX.HLP	Measurement window help text
SPU_TRANS.TXT	Operator dialog texts

Table 4:

Filename	Name
SPU_TFOA.HLP	Main dialog help texts V 2.3
SPU_TFOC.HLP	Adjust load voltage dialog help texts V 2.3
SPU_TFOF.HLP	Parallel info dialog help text V 2.3

1.6**Runtime files**

Text files containing SCIL code used during runtime. All files are stored in the directory \sc\Lib4\Smod\HVPROCESS\Use.

Table 5:

Filename	Name
SPU_UPDATE.TXT	Command file for force up value after Update deblock

2**Complete file listing**

This section contains a complete list of all files included in HV/Voltage Control package:

2.1**Installation files**

The following files are used during installation of the standard function and are located in the directory \sc\Lib4\Smod\HVPROCESS\Inst:

Table 6:

File	Description
SPI_TRANSB.PIC	Voltage Control function picture
SPI_TRANS.DAT	Voltage Control installation setup file
SPI_TRANSX.PIC	Measurement window function picture
SPI_TRANSX.DAT	Measurement window function setup file

2.2

Dialog files

The following files are used as dialogs of the standard function and are located in the directory \sc\Lib4\Smod\HVPROCESS\Use:

Table 7:

File	Description
SPU_TRANSA.PIC	Main dialogdialog for the Voltage Control function V 2.1
SPU_TRANSB.PIC	Operation info dialog for the Voltage Control function V 2.1
SPU_TRANSC.PIC	Adjust load voltage dialogdialog for the Voltage Control function V 2.1
SPU_TRANSD.PIC	Blockings dialog for the Voltage Control function
SPU_TRANSE.PIC	Blocking status dialog for the Voltage Control function V 2.1
SPU_TRANSF.PIC	Parallel info dialog for the Voltage Control function V 2.1
SPU_TRANSH.PIC	Maintenance dialog for the Voltage Control function
SPU_TRANSK.PIC	Block activation dialog for the Voltage Control function
SPU_TFOA.PIC	Main dialogdialog for the Voltage Control function V 2.3
SPU_TFOB.PIC	Operation info dialog for the Voltage Control function V 2.3
SPU_TFOC.PIC	Adjust load voltage dialogdialog for the Voltage Control function V 2.3
SPU_TFOE.PIC	Blocking status dialog for the Voltage Control function V 2.3
SPU_TFOF.PIC	Parallel info dialog for the Voltage Control function V 2.3
SPU_TFOF2.PIC	Parallel info dialog for the Voltage Control function V 2.4 (PARALLEL8)

2.3 Format picture files

The following files are used as format pictures of the standard function and are located in the directory `\sc\Lib4\Smod\HVPROCESS\Use`:

Table 8:

File	Description
FORM4S002.PIC	Blocking events
FORM4S003.PIC	Alarm events
FORM4S004.PIC	On/off events (BI)
FORM4S008.PIC	Analog value events
FORM4S013.PIC	Process station orders
FORM4S014.PIC	On/off events (AI)

2.4 Run-time command files

The following files are used during run-time and are located in the directory `\sc\Lib4\Smod\HVPROCESS\Use`:

Table 9:

File	Description
SPU_UPDATE.TXT	Force up values after update deblock for HV/Voltage Control.

2.5 Run-time text files

The following files are used during run-time for text presentation and are located in the directory `\sc\Lib4\Smod\HVPROCESS\Lang0`:

Table 10:

File	Description
FORM4S002.TXT	Texts for format picture form4s002
FORM4S003.TXT	Texts for format picture form4s003
FORM4S004.TXT	Texts for format picture form4s004
FORM4S008.TXT	Texts for format picture form4s008
FORM4S013.TXT	Texts for format picture form4s013
FORM4S014.TXT	Texts for format picture form4s014
SGU_INFO.TXT	dialog texts for the SGU_INFO dialog
SGU_INFO2.TXT	dialog texts for the SGU_INFO2 dialog
SGU_INFO3.TXT	dialog texts for the SGU_INFO3 dialog

2.6

Installation text files

The following files are used during installation for generation of object texts (OX attributes of the process objects) and are located in the directory

\sc\Lib4\Smod\HVPROCESS\Lang0:

Table 11:

File	Description
SPI_TRANS.TXT	Process object texts (for OX attribute) for the HV/Voltage Control function

2.7

Help files

The following files are used in the help dialogs and are located in the directory

\sc\Lib4\Smod\HVPROCESS\Lang0:

Table 12:

File	Description
SPI_TRANS.HLP	Help for the Configuration tool for the Voltage Control function
SPU_TRANSA.HLP	Help for the main dialog for the Voltage Control function
SPU_TRANSC.HLP	Help for the adjust load voltage dialog for the Voltage Control function
SPU_TRANSK.HLP	Help for the block activation dialog for the Voltage Control function
SPU_TRANSD.HLP	Help for the blockings dialog for the Voltage Control function
SPU_TRANSE.HLP	Help for the blocking status dialog for the Voltage Control function
SPU_TRANSH.HLP	Help for the maintenance dialog for the Voltage Control function
SPU_TRANSB.HLP	Help for the operation info dialog for the Voltage Control function
SPU_TRANSF.HLP	Help for the parallel info dialog for the Voltage Control function
SPU_TFOA.HLP	Main dialog help texts V 2.3
SPU_TFOC.HLP	Adjust load voltage dialog help texts V 2.3
SPU_TFOF.HLP	Parallel info dialog help text V 2.3

2.8

Representation files

The following files are used to store representations and are located in the directory `\sc\Lib4\Smod\HVPROCESS\Use:`

Table 13:

File	Description
SR_LIBFGH.PIR	HV window representation file
SLIB.PIR	SLIB representation file

3

Window representations

The following HV/Voltage Control representations are stored in the file `\sc\Lib4\Smod\HVPROCESS\Use\SR_LIBFGH.pir:`

Table 14:

Name	Description
SR_OBPIC	Object pictures representation
S_TRANS1	Voltage Control; Process picture representation, vertical, size 3*3
S_TRANS2	Voltage Control; Process picture representation, horizontal, size 3*3
S_TRANS3	Voltage Control; Process picture representation, vertical, size 2*2
S_TRANS4	Voltage Control; Process picture representation, horizontal, size 2*2
S_TRANS5	Voltage Control; Process picture representation, vertical, size 3*3, 3-winding left
S_TRANS6	Voltage Control; Process picture representation, vertical, size 3*3, 3-winding right

4 Process Objects

In this section the process objects belonging to the different standard functions are described. First are the different types stated.

4.1 Type definitions

The following basic types of process objects are defined for the HVLib. In the tables below “SPA” type objects are defined. For “LON” type objects (Station type “REX”), the DX attributes all start with X instead of N, e.g. X7S instead of N7S:

Table 15: Process object type 1

Attribute list	General Alarm with event handling via SPA	Description
DX	N7S	Directive Text
PT	BI	Process Object Type
OT	DEC	Output type
IU	YES	In Use
SS	MAN	Switch state
EE	YES	Event enable
HE	YES	History enabled
HA	NEW VALUE	History activation
HF	YES	History at first update
HL	32768	History log number
BI	0	Binary input value
RC	YES	Acknowledge required
AB	NO	Alarms blocked
AC	1	Alarm class
PI	ALARMS	Alarm picture
AG	1	Alarm generation
PD	1, 2, 3, 4, 5	Monitor number
PA	NEW VALUE	Printout activated at
PU	YES	Printout at first update
AD	0	Alarm delay
LD	1, 2	Listing device number

Table 16: Process object type 2

Attribute List	MicroSCADA Internal Indication with event handling	Description
PT	BI	Process Object Type
OT	DEC	Output type
IU	YES	In Use
SS	MAN	Switch state
EE	YES	Event enable
HE	YES	History enabled
HA	NEW VALUE	History activation
HF	YES	History at first update
HL	32768	History log number
BI	0	Analog input value
RC	YES	Acknowledge required
AB	NO	Alarms blocked
AC	0	Alarm class
PI	“ “	Alarm picture
PD	0	Monitor number
PA	NEW VALUE	Printout activated at
PU	YES	Printout at first update
AD	0	Alarm delay
LD	1, 2	Listing device number

Table 17: Process object type 3

Attribute list	General Indications with event handling via SPA	Description
DX	N7S	Directive Text
PT	BI	Process Object Type
OT	DEC	Output type
IU	YES	In Use
SS	MAN	Switch state
EE	YES	Event enable
HE	YES	History enabled
HA	NEW VALUE	History activation
HF	YES	History at first update
HL	32768	History log number
BI	0	Analog input value
RC	YES	Acknowledge required
AB	NO	Alarms blocked
AC	0	Alarm class
PI	ALARMS	Alarm picture
PD	1, 2, 3, 4, 5	Monitor number
PA	NEW VALUE	Printout activated at
PU	YES	Printout at first update
AD	0	Alarm delay
LD	1, 2	Listing device number

Table 18: Process object type 8

Attribute List	General Indication without event handling via SPA	Description
DX	N7S	Directive Text
PT	BI	Process Object Type
OT	DEC	Output type
IU	YES	In Use
SS	MAN	Switch state
EE	YES	Event enable
HE	NO	History enabled
BI	0	Binary input value
RC	YES	Acknowledge required
AB	NO	Alarms blocked
AC	0	Alarm class
PI	ALARMS	Alarm picture
PD	1, 2, 3, 4, 5	Monitor number
PA	NEW VALUE	Printout activated at
PU	YES	Printout at first update
AD	0	Alarm delay

Table 19: Process object type 9

	AI with event handling via SPA	Description
DX	N6	Directive Text
PT	AI	Process Object Type
OT	DEC	Output type
IU	YES	In Use
SS	MAN	Switch state
EE	YES	Event enable
HE	YES	History enabled
HA	WARNING	History activation
HF	YES	History at first update
HL	32768	History log number
AI	0.0	Analogue input value
HI	0.0	High alarm limit
HW	0.0	High warning limit
LW	0.0	Low warning limit
LI	0.0	Low alarm limit
SN	1_1	Scale name
SZ	SCADA	Limits supervised by
RC	YES	Acknowledge required
AB	NO	Alarms blocked
AC	1	Alarm class
PI	ALARMS	Alarm picture
PD	1, 2, 3, 4, 5	Monitor number
PA	WARNING	Printout activated at
PU	YES	Printout at first update
AD	0	Alarm delay
LD	1, 2	Listing device number

Table 20: Process object type 10

Attribute List	Digital input for internal function block	Description
PT	DI	Process Object Type
OT	DEC	Output type
IU	YES	In Use
SS	AUTO	Switch state
EE	NO	Event enable
HE	NO	History enabled
DI	0	Digital input value
RC	NO	Acknowledge required
AB	NO	Alarms blocked
AC	0	Alarm class
LD	0	Listing device number

Table 21: Process object type 11

Attribute List	Pulse counter with event handling via SPA	Description
DX	N8	Directive Text
PT	PC	Process Object Type
OT	DEC	Output type
IU	YES	In Use
SS	MAN	Switch state
EE	YES	Event enable
HE	YES	History enabled
HA	WARNING	History activation
HF	YES	History at first update
HL	32768	History log number
BC	16	Bit counter

Table 21: Process object type 11 (Continued)

Attribute List	Pulse counter with event handling via SPA	Description
SC	1	Scaling
RC	YES	Acknowledge required
AB	NO	Alarms blocked
AC	1	Alarm class
PI	ALARMS	Alarm picture
PD	1, 2, 3, 4, 5	Monitor number
PA	WARNING	Printout activated at
PU	YES	Printout at first update
AD	0	Alarm delay
LD	1, 2	Listing device number

4.2

HV/Voltage Control

Table 22: Process Objects for HV/Voltage Control

IX	Type	OB	Description (OX)	Format picture	RX (10 last characters)
1 ¹	9	5)	Ur2	FORM4S008	SPTAVRmur2
2 ¹	3	0 ³⁾	Tap changer in operation	form4s004	SPTAVRiTOP
3 ¹	9	5)	Bus Voltage, group average	FORM4S008	SPTAVRmBVO
4 ¹	9	5)	Present Setpoint voltage, group average	FORM4S008	SPTAVRmBVO
5 ¹	11	5)	Parallel Operation	FORM4S014	SPTAVRiope
6 ¹	11	5)	Operation, group average bus voltage	FORM4S014	SPTAVRiope
7 ¹	9	5)	LVA Input	FORM4S008	SPTAVRmBVO
8 ¹	1	0	Winhunt	form4s003	SPTAVRiHda
9 ¹	1	1	VT mismatch alarm	form4s003	SPTAVRiHda
10 ¹	9	5)	Tap position	FORM4S008	SPTAVRmPOS
11 ¹	9	5)	Bus voltage	FORM4S008	SPTAVRmBVO
12 ¹	9	5)	Uset	FORM4S008	SPTAVRmuse
13 ¹	9	5)	Load voltage	FORM4S008	SPTAVRmlvo
14 ¹	9	5)	Present Setpoint	FORM4S008	SPTAVRsset
15 ¹	9	5)	Total no of operations	FORM4S008	SPTAVRmcou
16 ¹	9	5)	Number of remaining op for con	FORM4S008	SPTAVRmcou
17 ¹	11	5)	Operation, Homing	FORM4S014	SPTAVRiope

Table 22: Process Objects for HV/Voltage Control

IX	Type	OB	Description (OX)	Format picture	RX (10 last characters)
18 ¹	11	5 ⁵⁾	Operation, Simultaneous tapping prohibited	FORM4S014	SPTAVRiope
19 ¹	3	2	Homing status	FORM4S004	SPTAVRicpg
21 ¹	3	10 ³⁾	T1 connected to parallel group	FORM4S004	SPTAVRicpg
22 ¹	3	11 ³⁾	T2 connected to parallel group	FORM4S004	SPTAVRicpg
23 ¹	3	12 ³⁾	T3 connected to parallel group	FORM4S004	SPTAVRicpg
24 ¹	3	13 ³⁾	T4 connected to parallel group	FORM4S004	SPTAVRicpg
25 ¹	1	9 ³⁾	Maximum circulation current	FORM4S003	SPTAVRIbcc
26 ¹	9	5 ⁵⁾	Load dependent auto. reduction	FORM4S008	SPTAVRilvf
27 ¹	9	5 ⁵⁾	Load voltage adjust factor 1	FORM4S008	SPTAVRilvf
28 ¹	9	5 ⁵⁾	Load voltage adjust factor 2	FORM4S008	SPTAVRilvf
29 ¹	9	5 ⁵⁾	Load voltage adjust factor 3	FORM4S008	SPTAVRilvf
30 ¹	9	5 ⁵⁾	Load voltage adjust factor 4	FORM4S008	SPTAVRilvf
31 ¹	3	0 ²⁾	Remote operation mode	form4s004	SPTAVRiom
32 ¹	3	1 ²⁾	Station operation mode	form4s004	SPTAVRiSom
33 ¹	3	2 ²⁾	Local operation mode	form4s004	SPTAVRiLOm
34 ¹	3	3 ²⁾	Local MMI operation mode	form4s004	SPTAVRimom
35 ¹	3	4 ²⁾	Manual control mode	form4s004	SPTAVRimcm
36 ¹	3	5 ²⁾	Automatic control mode	form4s004	SPTAVRiacm
37 ¹	3	5 ³⁾	Single regulation mode	form4s004	SPTAVRisrm
38 ¹	3	6 ³⁾	Parallel regulation mode	form4s004	SPTAVRiprm
39 ¹	3	7 ³⁾	Parallel/Adapt regulation mode	form4s004	SPTAVRipam
40 ¹	1	3 ⁴⁾	General voltage control error	form4s003	SPTAVRigve
41 ¹	1	1 ³⁾	Tap changer position error	form4s003	SPTAVRitpe
42 ¹	1	2 ³⁾	Tap changer command error	form4s003	SPTAVRitce
43 ¹	1	11 ²⁾	Tap changer operation error	form4s003	SPTAVRitoe
44 ¹	1	8 ³⁾	Bay to bay communication error	form4s003	SPTAVRibce
45 ¹	1	8 ²⁾	Hunting detection alarm	form4s003	SPTAVRiHda
46 ¹	3	5 ⁴⁾	T5 connected to parallel group	form4s004	SPTAVRicpg
47 ¹	3	6 ⁴⁾	T6 connected to parallel group	form4s004	SPTAVRicpg
48 ¹	3	7 ⁴⁾	T7 connected to parallel group	form4s004	SPTAVRicpg
49 ¹	3	8 ⁴⁾	T8 connected to parallel group	form4s004	SPTAVRicpg
51 ¹	3	14 ²⁾	Total block activation	form4s002	SPTAVRitba
52 ¹	3	6 ²⁾	Automatic block activation	form4s002	SPTAVRiaba
53 ¹	1	14 ³⁾	Over current block	form4s003	SPTAVRIocb
54 ¹	1	7 ²⁾	Under voltage block	form4s003	SPTAVRiuvb

Table 22: Process Objects for HV/Voltage Control

IX	Type	OB	Description (OX)	Format picture	RX (10 last characters)
55 ¹	1	15 ³	Reversed action blocking	form4s003	SPTAVRirab
56 ¹	1	9 ²	Low voltage tap position	form4s003	SPTAVRiltp
57 ¹	1	10 ²	High voltage tap position	form4s003	SPTAVRihtp
58 ¹	1	4 ³	High voltage	form4s003	SPTAVRihvl
59 ¹	1	3 ³	Low voltage	form4s003	SPTAVRilvl
60 ¹	3	15 ²	Transformer disconnection	form4s002	SPTAVRidis
65 ¹	11	5)	Operation, Voltage control	form4s014	SPTAVRiope
66 ¹	11	5)	Operation, Reversed action	form4s014	SPTAVRiora
67 ¹	11	5)	Operation, Line volt drop comp	form4s014	SPTAVRildc
68 ¹	9	5)	Fast step down function mode	form4s008	SPTAVRifsd
69 ¹	9	5)	Setpoint voltage deadband	FORM4S008	SPTAVRmvol
70 ¹	9	5)	High voltage	FORM4S008	SPTAVRmVOL
71 ¹	9	5)	Low voltage	FORM4S008	SPTAVRmVOL
72 ¹	9	5)	Circulating current	FORM4S008	SPTAVRmcur
73 ¹	9	5)	Circulating current block limit	FORM4S008	SPTAVRmcur
74 ¹	9	5)	Transformer identity in the parallel group	FORM4S008	SPTAVRimst
210 ¹	6		Tap command	form4s013	SPTAVRccmd
240	8		Events	form4s002	SPTAVREVE
241	8		Alarms	form4s002	SPTAVRALA
242	8		Printout	form4s002	SPTAVRxPRI
243	10		Function occ. by other monitor	-	sptavrxmisc
244	8		Rem. events and ind.	form4s002	SPTAVRxREM
245	8		Update	form4s002	SPTAVRxALA
249	2		Transformer routing prim. info	FORM4S002	SPTAVRxTRR
253	2		Transformer fict. pos. ind.	FORM4S002	SPTAVRxTRF
255	12		Transformer predefined color	FORM4S002	SPTAVRxTRC

1. Must be set to switch state AUTO (SS=2) before commissioning
2. The signals are connected to event block 11
3. The signals are connected to event block 12
4. The signals are connected to event block 9
5. The signals are direct connected to analog input
6. The signals in *Italic* are put to not in use if the HV/Voltage Control is configured as single.

5 Object list

This section gives a description of all the MicroSCADA objects (command procedures, event channels, datalog objects etc.) which are created and used by the HV/Voltage Control package after installation of the package. The below is thus created in addition to the files included in the package - See “Complete file listing” on page 59.

5.1 Command procedures

The following command procedures are created and used.

Table 23:

Command procedure	Description
SPU_UPDATE	Fetch values from RET after Update deblock

5.2 Datalog objects

The following datalog objects are created and used.

Table 24:

Datalog object	Description
A_HTIMEOUT	dialog timeout

5.3 Scale objects

The following scale objects are created and used.

Table 25:

Scale object	Description
1_1	Standard scale - created only if it does not exist previously

6 Format pictures and status texts

The following format pictures are included and used by HV/Voltage Control:

Table 26:

Format picture	Value	Status text
form4s002	1	Blocked
	0	Deblocked
form4s003	1	Alarm
	0	Normal
form4s004	1	On
	0	Off
form4s008	>=HI	High alarm H2
	>=HW & <HI	High warning H1
	>LW & <HW	Normal value
	>=LW & <LI	Low warning L1
	>=LI	Low alarm L2
form4s013	1	Set Manual
	2	Set Auto
	4	Raise tap position
	8	Lower tap position
	16	Set Remote
	32	Set Station
	64	Reset of factors 1 to 4
	128	-
	256	Total blocking on
	512	Auto mode blocking on
	1024	Total blocking off
	2048	Auto mode blocking off
form4s014	4096	Activation of factor 1
	8192	Activation of factor 2
	16384	Activation of factor 3
	32768	Activation of factor 4
form4s014	1	On
	0	Off

7 Updated files

In this section the updates made to dedicated files during installation is described.

7.1 PATH4_S1.TXT

During startup after installation the file the contents of the file `path4_s1.txt` is added to the file `[drive]:\sc\lib4\base\bbone\use\path4.txt`.

7.2 INDEX4_S3.TXT

During startup after installation the file the contents of the file `index4_s3.txt` is added to the file `[drive]:\sc\lib4\base\bbone\inst\mlib_index.txt`.

Software Registration Form

Program:

This card registers your program and makes you eligible to receive information about future updates.

Name:

Title:

Company:

Dept.

Address:

City:

State:

Zip:

Phone:

Fax:

Program supplied by:

Adress:

City:

State:

Zip:

Phone:

Date of receival of the program:

Program serial Nr:

Fascimile:

Please send this registration card to ABB Automation Technologies AB, Substation Automation Products, Support Line (+46 (0) 21 14 69 18)

Remove from binder

Place
postage
stamp
here

ABB Automation Technologies AB
Substation Automation Products
Support Line
SE-721 59 Västerås
Sweden

To be folded

Remove from binder

Tape here

Product:

ABB Automation Technologies AB would appreciate your comments on this product. Please grade the following questions by selecting one alternative per category. Your answer will enable us to improve our products.

How do you grade the quality of the product?

	Excellent				Poor
Total impression	<input type="checkbox"/>	<input type="checkbox"/>	<input type="checkbox"/>	<input type="checkbox"/>	<input type="checkbox"/>
Useability	<input type="checkbox"/>	<input type="checkbox"/>	<input type="checkbox"/>	<input type="checkbox"/>	<input type="checkbox"/>
Functionality	<input type="checkbox"/>	<input type="checkbox"/>	<input type="checkbox"/>	<input type="checkbox"/>	<input type="checkbox"/>
Human machine interface	<input type="checkbox"/>	<input type="checkbox"/>	<input type="checkbox"/>	<input type="checkbox"/>	<input type="checkbox"/>

Comments: _____

How do you grade the quality of the documentation?

	Excellent				Poor
Total impression	<input type="checkbox"/>	<input type="checkbox"/>	<input type="checkbox"/>	<input type="checkbox"/>	<input type="checkbox"/>
Layout	<input type="checkbox"/>	<input type="checkbox"/>	<input type="checkbox"/>	<input type="checkbox"/>	<input type="checkbox"/>
Illustrations	<input type="checkbox"/>	<input type="checkbox"/>	<input type="checkbox"/>	<input type="checkbox"/>	<input type="checkbox"/>
Readability	<input type="checkbox"/>	<input type="checkbox"/>	<input type="checkbox"/>	<input type="checkbox"/>	<input type="checkbox"/>
Easy to find	<input type="checkbox"/>	<input type="checkbox"/>	<input type="checkbox"/>	<input type="checkbox"/>	<input type="checkbox"/>
Content structure	<input type="checkbox"/>	<input type="checkbox"/>	<input type="checkbox"/>	<input type="checkbox"/>	<input type="checkbox"/>

Comments: _____

A

Acknowledge alarms *30, 34, 37, 40*
Addressing *25*
Authority *35, 36, 40, 46*

B

Blockings *31, 35*

C

Colour coding *31*

F

Format picture files *61*

I

Installing the library function *14*
Installing the software *14*

L

LIB520 *9*
LON *13, 16, 21, 26, 29, 64*

M

MicroLIBRARY *13*
MicroSCADA *14*
MicroSYS *13*
mlib_index.txt *15*

O

Object Picture *47*
Object picture *50*
Obsolete value *34*

P

PATH4.TXT *15*

R

Readme file *14, 15*
Remaining tasks *25*
RET 521 *29*

S

Selected object *31, 32*
Selection *33*
SPA *13, 16, 64*
Station type *16*
Switch state *25*
SYS_BASCON.COM *16*

T

Terminal *13*

U

Unacknowledged alarm *31, 34*



ABB Automation Technologies AB

License Agreement

IMPORTANT - READ CAREFULLY BEFORE OPENING

This legal document is an agreement between You, the user, and ABB Automation Technologies AB, Västerås, SWEDEN. **By opening the diskette package You indicate your acceptance of the terms and conditions of this agreement.** If You do not agree to the terms of this agreement, promptly return the unopened diskette package and other items which are part of the product for a full refund. Your product is a single user version unless you have a written agreement with ABB Automation Technologies AB.

SOFTWARE LICENSE

- 1. Grant of License**
 - This ABB Automation Technologies AB License Agreement ("License") grants you the nonexclusive right to use one copy of the enclosed software program ("SOFTWARE") on a single computer (i.e., with a single CPU) at a single location at any time. If you have multiple Licenses for the SOFTWARE you may have as many copies of the SOFTWARE in use as you have Licenses.
- 2. Copyright**
 - The software is owned by ABB Automation Technologies AB or its suppliers and is protected by Swedish copyright laws, international treaty provisions, and all other applicable national laws. Therefore you must treat the SOFTWARE as any other copyrighted material (e.g., a book or musical recording) except that if the software is not copy protected you may either (a) make a copy of the SOFTWARE solely for backup or archival purposes, or (b) transfer the SOFTWARE to a single hard disk provided you keep the original solely for backup or archival purposes. You may not copy the Documentation accompanying the SOFTWARE.
- 3. Term**
 - The License is effective until terminated. This License will terminate automatically without notice from ABB Automation Technologies AB if you fail to comply with any provision of this License. Upon termination you shall return the diskettes containing the SOFTWARE and all Documentation to ABB Automation Technologies AB and destroy any copies of the SOFTWARE or any portions of it which has not been returned to ABB Automation Technologies AB, including copies resident in computer memory.
- 4. Other Restrictions**
 - You may not rent, lease, lend, sell or give away the SOFTWARE, but you may transfer your rights under this ABB Automation Technologies AB License Agreement on a permanent basis provided you transfer all copies of the SOFTWARE and all written materials, and the recipient agrees to the terms of this Agreement. You may not modify, adapt, translate, reverse engineer, decompile, disassemble, or create derivative works based on the SOFTWARE. You may not modify, adapt, translate or create derivative works based on the written materials.

LIMITED WARRANTY

- Limited Warranty** • ABB Automation Technologies AB warrants that the software will perform substantially in accordance with the accompanying Product Manual(s) for a period of 1 year from the date of delivery from ABB Automation Technologies AB, Västerås. ABB Automation Technologies AB does not warrant that the SOFTWARE is free from coding errors.
- Customer Remedies** • ABB Automation Technologies AB's entire liability and your exclusive remedy shall be, at ABB Automation Technologies AB's option, either (a) return of the price paid or (b) repair or replacement of the SOFTWARE that does not meet ABB Automation Technologies AB's Limited Warranty and which is returned to ABB Automation Technologies AB with a copy of your receipt. This Limited Warranty is void if failure of the SOFTWARE has resulted from accident, abuse, or misapplication. Any replacement SOFTWARE will be warranted for the remainder of the original warranty period or 30 days, whichever is longer.
- No Other Warranties** • ABB Automation Technologies AB disclaims all other warranties, either express or implied, including but not limited to implied warranties of merchantability and fitness for a particular purpose, with respect to the SOFTWARE, accompanying Product Manual(s) and written materials. This warranty gives you specific legal rights.
- No Liability for Consequential Damages** • Neither ABB Automation Technologies AB nor anyone else who has been involved in the creation, production or delivery of this product shall be liable for any direct, indirect, consequential or incidental damages (including damages for loss of business profits, business interruption, loss of business information, and the like) arising out of the use or inability to use such product even if ABB Automation Technologies AB has been advised of the possibility of such damages. In any case, ABB Automation Technologies AB's entire liability under any provision of this agreement shall be limited to the amount actually paid by you for the software.

ACKNOWLEDGEMENT

By opening the diskette package you acknowledge that you have read this agreement, understand it, and agree to be bound by its terms and conditions. You also agree that it is the complete and exclusive statement of the agreement between the parties and supersedes all proposals or prior agreement, oral or written, and any other communications between the parties relating to the subject matter of the licence or limited warranty.

This Agreement is governed in all aspects by Swedish law. If any provisions of this Agreement are invalid or unenforceable, all others will remain in effect.



ABB Automation Technologies AB

Substation Automation Products

SE-721 59 Västerås

Sweden

Telephone: +46 (0) 21 34 20 00

Facsimile: +46 (0) 21 14 69 18

Internet: www.abb.com/substationautomation

1MRK 511 116-UEN/2.3