



PS1 – S1-04



Integrated Protection Scheme for Pump-Storage Hydroelectric Power Plant

Zoran GAJIC¹, Joseph MENEZES¹, Dušan TRISIC², Mijodrag CITAKOVIC²
ABB SA Products¹, PD Drinsko-Limske HPP, Bajina Bašta²
Sweden¹, Serbia²
zoran.gajic@se.abb.com

KEYWORDS

Integrated Protection Scheme, Generator Protection, Pump Storage Power Plant.

1 INTRODUCTION

The Bajina Bašta Pump-Storage Plant is located in the vicinity of town Perućac on river Drina. Its two turbines operate with a net hydraulic head of approximately 600 meters between an upper reservoir located on the top of Tara mountain and the lower lake formed by a dam on the Drina river. Each generator/motor-transformer unit has rating of 315MVA, 11/220kV, 428.6rpm. In addition to these two units another four 100MVA generators are constructed within the dam and are used as stand-alone generators.

Phase reversal disconnectors are located at the high-voltage side of the step-up transformer in the 220kV switchyard, as shown in Figure 2. A 220kV substation connecting these units to the national grid is located 8km away. As a consequence two circuit breakers in series are installed on the HV side of the step-up transformer in order to secure separation of the unit from the system during any fault conditions. Additionally, due to transport limitations, each unit step-up transformer is built by parallel connection of two tanks where each tank has rating of 160MVA.

This plant was put in operation in 1982 when the original protection scheme was designed using discrete electromechanical relays with induction discs. Due to aging of the existing equipment new protection scheme is needed. However, these two pump-storage units have the following particular operating conditions which need to be taken in to consideration during design of the protection scheme with numerical relays:

- Generator operating mode of the unit
- Pump operating mode of the unit
- Back-to-back starting of the unit in pump operating mode
- Electrical braking of the synchronous machine for both generator and pump operating modes

Logical programming capability of the numerical relay makes it possible to automatically detect active operating conditions and to automatically adapt relay operation to the present operating condition of the unit. Thus an adaptive protection is actually used to protect these two units.

Regardless of the installation complexity, the complete protection scheme for one pump-storage generator/motor-transformer unit is integrated in a single numerical IED.

2 REQUIREMENTS ON THE FAULT CLEARANCE SYSTEM

The design of a protection and control system must always be based on the basic requirements of the power system. Generally accepted design principles that fulfill these requirements have been established and used for a long time.

Increased performance and capacity of IEDs has led to solutions where all functionalities for one power system object are integrated in one IED. Even the total protection and control functionality

for a hydroelectric power plant unit can be integrated in a single modern IED. In spite of a high degree of functional integration the basic requirements regarding reliability must be fulfilled.

This paper describes the design of an integrated numerical protection scheme for a pump-storage generator/motor-transformer unit. Regardless of the application complexity, the complete protection scheme for one unit can be integrated within a single numerical multifunctional IED. With this high degree of functional integration it is important to pay particular attention to the design of the complete protection system to guarantee the requirements regarding dependability and security. The paper will also discuss the requirements for the protection and fault clearance system.

There are many different requirements on fault clearance systems like reliability, speed, selectivity and sensitivity. For the purpose of this paper we will limit our discussion to the reliability issue. The reliability is probably the most fundamental and important property of the fault clearance system. The reliability of protection includes dependability of protection and security of protection.

Dependability is the probability for a protection of not having a failure to operate under given conditions for a given time interval. In other words a protection function with high dependability will have a high probability to operate correctly when wanted.

Security is the probability for a protection of not having an unwanted operation for a given time interval. A function with high security will have a low probability to operate when unwanted.

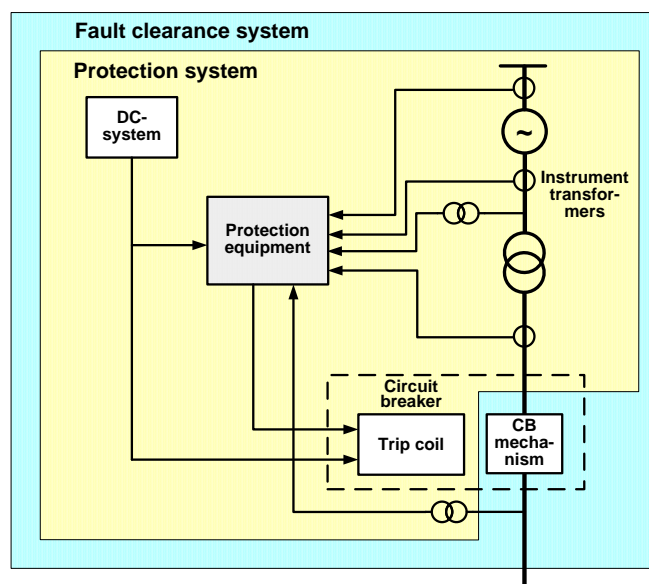

Fig. 1: Borders of protection and fault clearance systems

By definition the protection system consists of instrument transformers, protection equipment, auxiliary supply, tripping circuit including the circuit breaker trip coil and all necessary wirings. To perform successful clearing of power system faults the protection system and the circuit breaker must operate correctly. Therefore we define the fault clearance system as the protection system together with the circuit breaker mechanism. It includes all functions for automatic clearing of power system faults. All components in the fault clearance system have to operate properly to guarantee a reliable clearing of a fault. Independent of the high performance and quality the protection equipment may have, it is of no use if any of the other components in the fault clearance system fails. Figure 1 shows a fault clearance system of a generator unit.

We cannot assume that all components in the fault clearance system always will operate correctly. It is well known that protection equipment and circuit breakers sometimes can fail or that loss of input from voltage and current transformers can occur. Interruption of the DC supply or of a tripping circuit may also happen. It is normally not accepted that these kinds of faults in the fault clearance system result in a failure to trip in case of a fault in the generator unit or a power system fault.

As each of the components in the fault clearance system has a low risk of failure it has become a common practice to apply the single-failure criterion in the planning and designing of the fault clearance system.

The single-failure criterion requires that the failure of any one component in a fault clearance system should not result in a complete failure to clear a power system fault. It is a commonly accepted design principle that the basic power system requirements, regarding dependability, are fulfilled if the single-failure criterion has been applied.

The practical application of the single-failure criterion means that the performance of the fault clearance system has to be studied during different conditions and power system faults must be possible to clear, in an acceptable way, even if there is one failure in the fault clearance system. The following shows examples of failures that shall be considered:

- Loss of input from voltage and current transformers
- Failure to operate of a protection equipment or a protection function
- Interruption of the DC supply
- Interruption of the tripping circuit
- Failure to operate of a circuit breaker

It is obvious that some kind of back-up protection or redundancy is required to fulfill the single-failure criterion. This redundancy can be achieved by a second main protection or some kind of backup protection in separated devices. Generally the main protection and the back-up protection may reside in different substations, remote back-up, or in the same substation, local back-up (or local second main protection). A local back-up or a second main protection system is normally the required solution for a larger important generator unit to fulfill the single-failure criterion. A second main protection system must never be integrated in the same equipment as the first main protection. In systems with just one main protection, the backup protection system must not be integrated in the same equipment as the main protection.

3 GENERATOR-MOTOR UNIT OPERATING MODES

The two generator/motor-transformer units have the following particular operating modes which need to be taken in consideration during design of the integrated protection scheme with numerical IED:

- Generator operating mode of the unit
- Pump operating mode of the unit
- Synchronous start [5,6] of the unit into pump mode
- Electrical braking of the synchronous machine for both generator and pump operating modes

Logical programming capability of the numerical multifunctional IED [1,3] makes it possible to automatically detect actual operating condition of the unit and accordingly adapt relay operation. In the following subsections different operating modes of the two units will be briefly described.

3.1 Generator and pump operating modes

The main differences between the generator and pump operating modes are changes in direction of the synchronous machine rotation and change of direction (i.e. sign) of the active power flow. Change of the rotation direction practically causes swapping of the positive and negative sequence quantities measured by the protection scheme. This must be taken into consideration during protection scheme design. Especially numerical generator protection relays can be affected because operation of many protection functions can be based on current and voltage sequence components. Change of active power flow (i.e. sign) can affect over/under power relays integrated in the numerical multifunctional IED.

3.2 Synchronous start

The 315MVA unit is started as a synchronous motor by a 100MVA generator located in the dam, with both units initially at standstill. The necessary switching is performed to disconnect two machines from the 220kV transmission system and to connect the 100MVA generating unit to the 315MVA pumping unit. For this purpose 89S disconnector is used as shown in Figure 2. Note that the two machines are actually interconnected over short 220kV line, thus the step-up transformers are connected in series and are also included in the overall start up circuit. The fields of both units are energized and the generator turbine gates are opened to a predetermined position. Both the generator and the motor will accelerate together. Once the full speed of rotation is achieved the pump unit is then synchronized with the 220kV transmission system, at which time the generating unit is

disconnected, and consequently disconnecter 89S is opened. Then the pump is loaded to approximately 300MW. Sometimes this start method is called back-to-back start in the literature. In this particular plant synchronous start is fully automatized and it takes altogether around five minutes to complete. However its operation shall be supervised by the protection scheme and in case of any malfunction, the two machines shall be quickly separated.

Synchronous start causes linear frequency variations of motor current and voltage signals from 0 to 50Hz as well as linear voltage magnitude increase from 0% to 100% at machine terminals. Such conditions will have effects on many protection functions. Thus, the IED must be capable to measure and track the actual power system frequency in order to ensure proper operation of all protection functions integrated within the IED during this start condition.

3.3 Electrical braking

A period of time which is required to stop a salient-pole synchronous machine, without any additional braking actions, in many cases can be longer than half an hour. Such prolonged low-speed operation can be dangerous for the machine bearings due to low oil pressure. Thus, mechanical braking is frequently used to bring the turbine and rotor of a hydro-generator to a standstill. Such brakes operate on a principle of mechanical friction which slows down a rotating mass of the generator. In case of peak-load and pump-storage power plants where frequent unit starts and stops are required, the mechanical braking does not offer the optimal solution due to high maintenance demands. In such cases electric braking is often used. In this particular case after separation of 315MVA unit from the network its rotational speed reduces naturally to 50% quite quickly, however if no additional actions are taken it will take more than 15 minutes until rotor comes to standstill.

In order to speed-up this process electrical braking is applied. In this particular plant, when unit speed falls to 50% of the rated speed, disconnecter 89DB is closed (see Figure 2). This operation effectively makes a three-phase short circuit at the machine terminals. Then the field current is applied which is sufficient to induce 80% of the rated current in the stator. These two currents will then produce a braking torque which will stop the machine rotor within approximately five minutes. For quite low speed of rotation, mechanical brakes are also applied. Electrical braking is used in both the generator and the pump operating modes.

While electrical braking is active, voltage at the machine terminals will be practically zero. This will in effect disable any frequency tracking features within numerical IED which is based on voltage measurement [1]. At the same time the stator current will have almost constant magnitude but with frequency variation from approximately 25Hz down to 0Hz. Such condition will unquestionably have effect on many protection functions and special means are required to prevent unwanted relay operation and to provide dedicated protection functionality for this particular operating condition.

4 INTEGRATED ADAPTIVE PROTECTION SCHEME

Connected instrument transformers to the numerical IED are shown in Figure 2. Auxiliary contact status of all primary apparatuses, shown in this figure, is also made available to the IED as double point indications. Finally additional binary signals such as: wicket-gate closed; speed larger than 80%; synchronous start mode selected and machine stop order are also wired to the IED. Logical programming capability of the IED is then used in order to derive actual operating mode of the unit. This information is then used to adjust the operation of various protection functions integrated within the IED. Thus an adaptive protection is actually used to protect these units.

4.1 Protection functionality integrated in the single IED

Frequency tracking is available in the IED and will measure and track actual system frequency by utilizing voltage signals at the machine terminals. This will enable use of almost all protection functions integrated within IED during all unit operating modes with the exception during electrical braking. During synchronous start this feature will be fully operational already when measured voltage has frequency around 9Hz.

Differential protections 87G and 87T require no special treatment because phase reversal disconnectors are located outside their protection zones (see Figure 2). However, 87T restraint stage must be blocked during electrical braking and special treatment is required during extremely low frequency condition (i.e. 2Hz-10Hz) when frequency tracking feature is not fully operational, as described in the next paragraph.

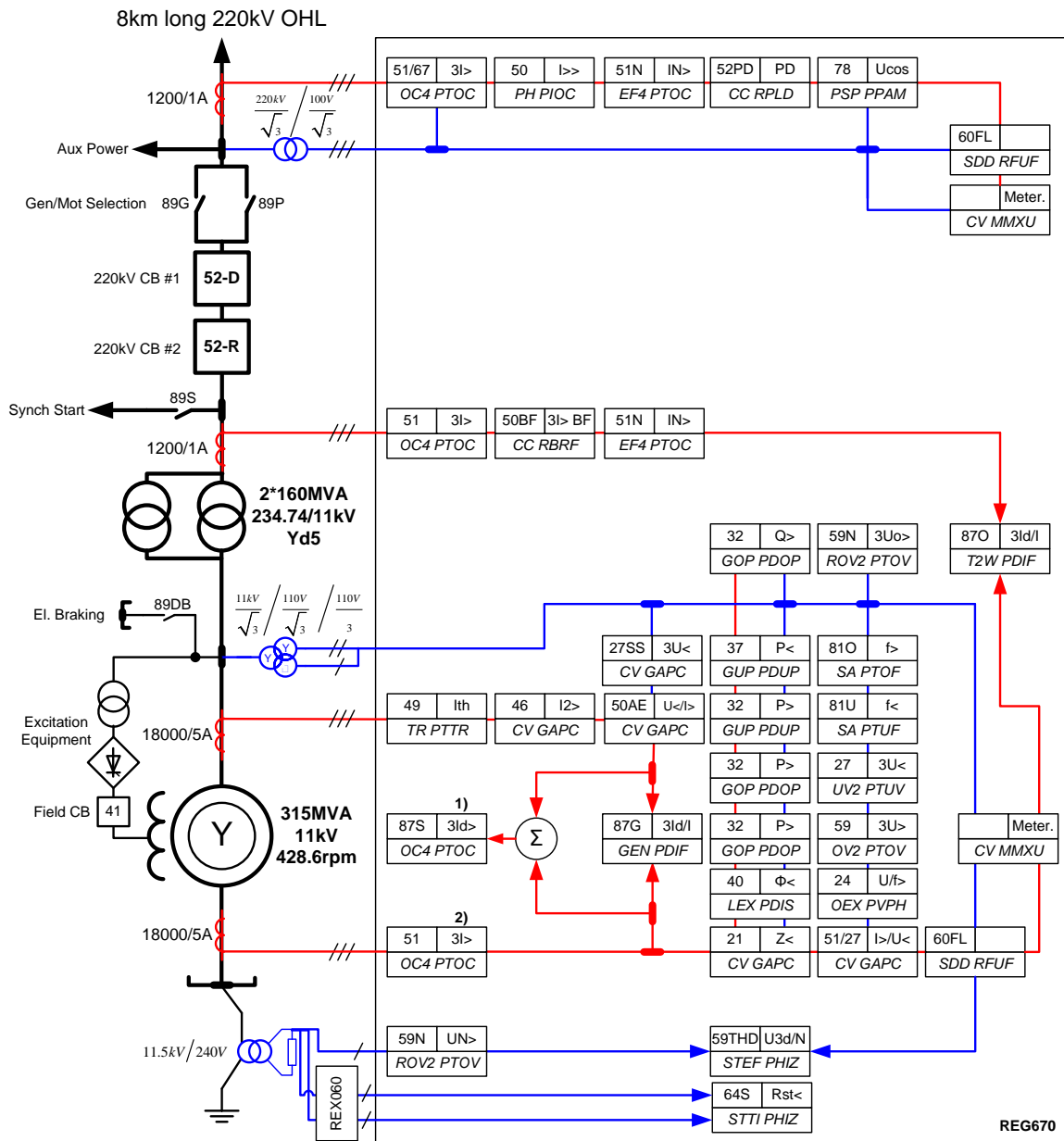

Note:

- 1) Overcurrent function used as generator diff during starting and el-braking (pickup from 2Hz)
- 2) Overcurrent function used during back-to-back starting and el-braking (pickup from 2Hz)

LEGEND:	
ANSI	IEC
IEC 61850	

Fig. 2: Used protection scheme for one generator/motor-transformer unit using single numerical IED

Generator low-frequency differential protection 87S [7] is only active while machine is in synchronous start or electrical braking operating mode. It is realized by using an overcurrent function which measures sum of the currents from the two sides of the stator winding. Note that any biasing is not required because external faults are not practically feasible during these two operating modes. This function is able to operate from approximately 2Hz and it is set to 15% of the machine rating.

Machine overcurrent protection 51 is realized by using an overcurrent function with four stages. Two stages are used as time-delayed backup protection during normal machine operation. Third instantaneous stage set at 50% of the machine rating is only active during synchronous start while the fourth instantaneous stage set at 125% is only active during electrical braking. This function is able to operate from approximately 2Hz.

Negative sequence protection 46 is realized by using two sequence functions. The first function measures the negative sequence current and it is only active while the machine is rotating as generator.

The second function measures the positive sequence current and it is only active while machine is rotating as motor. Both functions have pickup and time delay set in accordance with the machine capability.

95% stator earth fault protection 59N measures fundamental frequency voltage at machine neutral point and it is active in all operating modes of the unit.

100% 3rd harmonic based, stator earth fault protection 59THD is based on third harmonic differential principle and it is active in all operating modes of the unit.

100% injection based, stator earth fault protection 64S is based on injection of an 87Hz signal and it is active in all operating modes of the unit.

80% stator earth fault protection 59N measures fundamental frequency, open delta voltage at machine terminals and it is active in all operating modes of the unit.

Under-impedance protection 21 has two zones and it is blocked during synchronous start and electrical braking.

Over-current protection with under-voltage seal-in 51/27 has one operating stage and it is blocked during synchronous start and electrical braking.

Loss of excitation protection 40 is based on ph-to-ph impedance measurement and it is blocked during synchronous start and electrical braking.

Fuse failure feature 60FL for 11kV VT is based on $\Delta I/\Delta U$ principle and it is blocked while the machine is not synchronized to the 220kV transmission system. Note that sequence based fuse failure schemes will be affected by generator/motor operating mode.

Accidental energizing protection 50AE is based on voltage supervised over-current principle but it is blocked during synchronous start and electrical braking.

Machine thermal overload protection 49 is based on true RMS current measurement. It is active in all operating modes.

Power functions 32 and 37 are using Arone-connection (Two Wattmeter Method) which insures proper total three-phase P and Q measurements including directionality during all operating modes of the unit. One under-power stage, set at 50%, is used for direct tripping in motor operating mode (loss of power protection), while another stage, set at 105%, is used as active, over-power protection in both motor and generator operating modes. Other six stages are used as inputs into the plant control system.

Over-frequency protection 81O has two operating stages. The first stage is only active while machine is connected to the network. The second stage is always active and it is set at 150% of rated frequency. It is used as backup protection to the mechanical over-speed protection device. This high setting is selected in order to coordinate during load rejection when machine is operating in generator mode.

Under-frequency protection 81U is only active in pump operating mode.

Over-voltage protection 59 measures three ph-to-ph voltages and it is active in all operating modes.

Under-voltage protection 27 measures three ph-to-ph voltages and it is only active in pump operating mode.

Under-voltage protection 27SS measures the maximum ph-to-ph voltage. It is used as additional protection function which is only active during synchronous start and when machine speed exceeds 80%. It shall detect that motor excitation system has failed to transfer to permanent excitation supply which is taken directly from the machine terminals. It is set to 50% with 1s delay.

Over-excitation protection 24 is based on ph-to-ph voltage measurements and it is blocked during electrical braking.

Step-up transformer HV side over-current protection 51 is realized by using an overcurrent function with four stages. Two stages are used as time-delayed backup protection during unit normal operation. Third instantaneous stage set at 75% of the transformer rating is only active during synchronous start with time delay of 0.2s.

Step-up transformer HV side earth fault protection 51N is realized by using a residual overcurrent function with four stages. Only two stages are used and they are always active.

Unit circuit breaker failure protection 50BF is connected to step-up transformer HV CTs and it can be used to send inter-trip command to the remote substation in an unlikely event of the two 220kV breakers failing to trip.

220kV OHL instantaneous over-current protection 50 is set to 9.6kA primary and it is used to instantly trip for any fault in power plant 220kV switchyard.

220kV OHL over-current protection 51/67 is used as backup protection for 8km long 220kV OHL.

220kV OHL earth fault protection 51N is used as backup protection for 8km long 220kV OHL.

Pole discordance protection 52PD is used to detect failure of the primary apparatuses to open/close all three poles.

Pole slip protection 78 is connected to 220kV line CTs and VTs outside of the phase reversal disconnectors, which enables use of positive sequence quantities for this protection irrespective of the generator or pump operating mode of the unit. Function is based on $U\cos\phi$ principle.

Fuse failure feature 60FL for 220kV VT is based on measurement of negative and zero sequence quantities and it is always enabled.

Tripping matrix is designed to emulate existing tripping arrangements used by discrete electromechanical relays.

4.2 Metering and monitoring functionality integrated in the IED

The IED provides P, Q, S, U, I, f and $\cos\phi$ measurements at generator terminals as well as for the 220kV line. These measurements are shown as on-line service values on the single line diagram which is available on the IED built-in HMI, (see Figure 3). This facilitates testing, commissioning and trouble shooting of the integrated protection scheme [4].

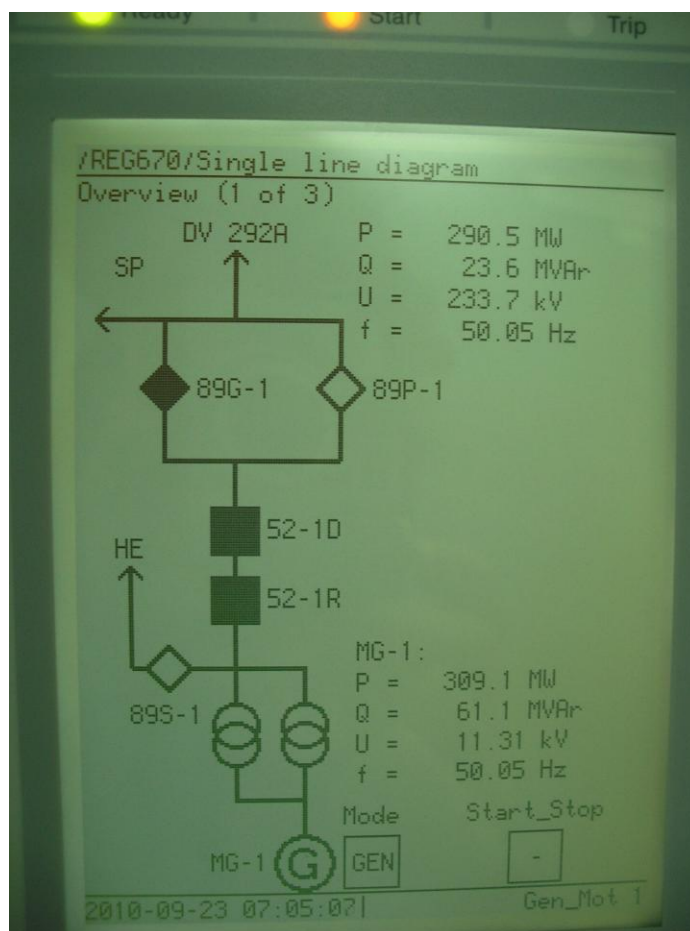

Fig. 3: Built-in single line diagram with on-line measurements

Built in disturbance recorder and event list provide information about IED operation during secondary and primary testing [4] as well as during different operating modes of the unit. Internally calculated quantities such as P, Q, f and differential currents are also recorded.

Programmable LEDs provide quick operator overview about protection function which caused tripping of the unit. The IED also displays the operating mode of the unit on the built-in HMI as determined by the logic programmed within the relay.

It was noted that using bistable logical elements (i.e. flip-flop) with memory insures correct operation of the IED in case of DC supply failure or DC supply change-over for plant status indication circuits.

5 FIELD EXPERIENCE

Two IEDs, one per generator/motor-transformer unit, with integrated protection scheme were put in services in August 2009. Since then, operating experience was completely in accordance with expectations. During October 2009 minor modifications to the relay configuration and settings were performed in order to optimize usage of the built-in disturbance recorder and event list during different operating modes of the units. Additional function 27SS was also introduced into the scheme in order to ensure detection of supply commutation failure within excitation system of the 315MVA motor unit during synchronous start mode.

Note that in all of the following figures letters R, S and T are used to designate the individual phases in a three-phase system instead of more commonly used A, B, C (ANSI) or L1, L2 and L3 (IEC). Such phase designations are in accordance with end user current practice (old VDE standard).

Note that in all of the following figures the following units are used: secondary amperes for currents; secondary volts for voltages; percentages for active and reactive power (base 315MVA) and hertz for frequency.

In Figure 4, Figure 5 and Figure 6 disturbance recordings captured during electrical breaking are shown. On each of these three figures the following quantities measured by the protection relay are shown:

- a) Three phase to ground voltage waveforms in the 220kV power system
 (note that frequency of these signals is always 50Hz)
- b) Three phase current waveforms at synchronous machine terminals

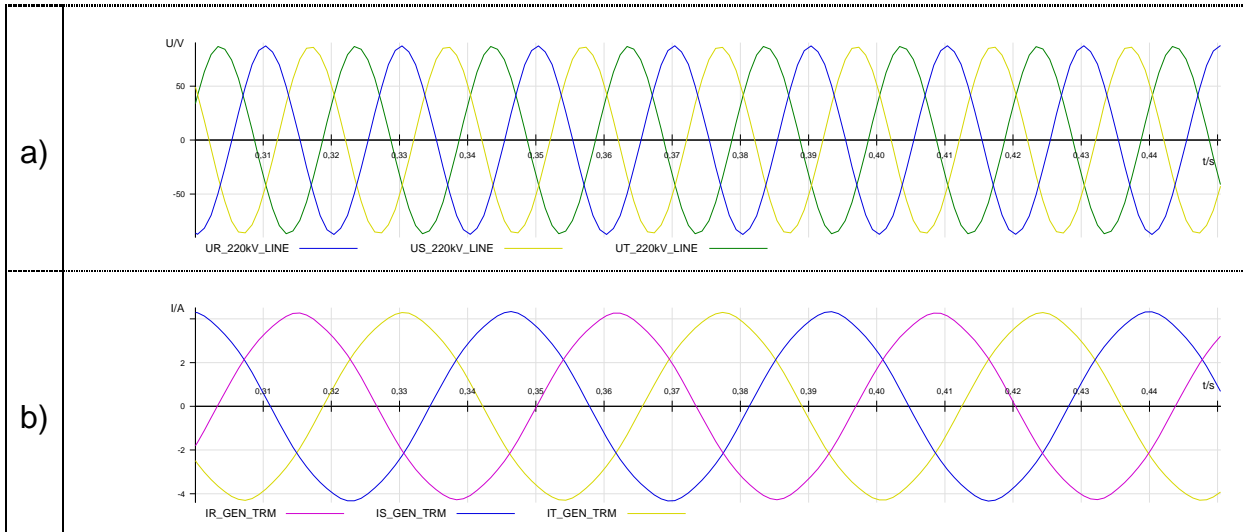
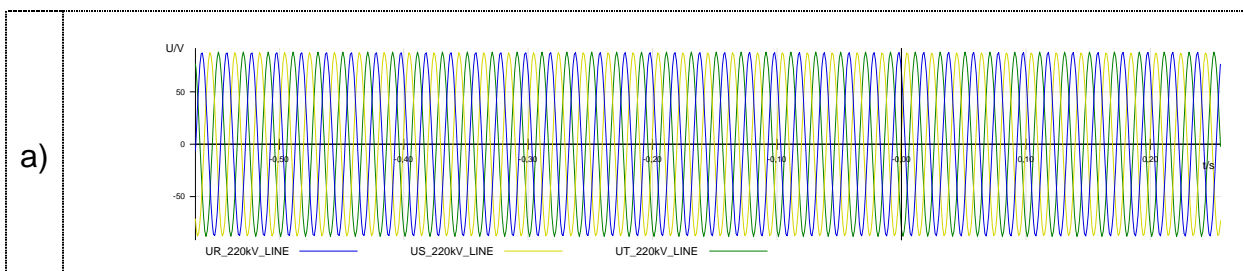

Fig. 4: Start of electrical breaking in pump mode (stator current frequency is close to 25Hz)



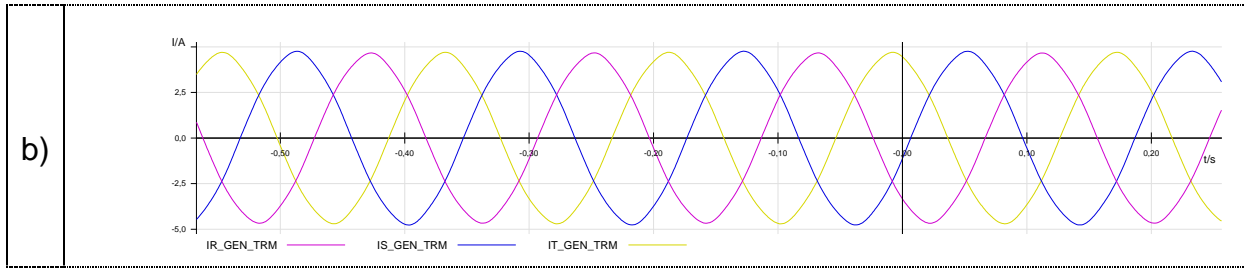

Fig. 5: Electrical breaking in pump mode (stator current frequency around 5.5Hz)

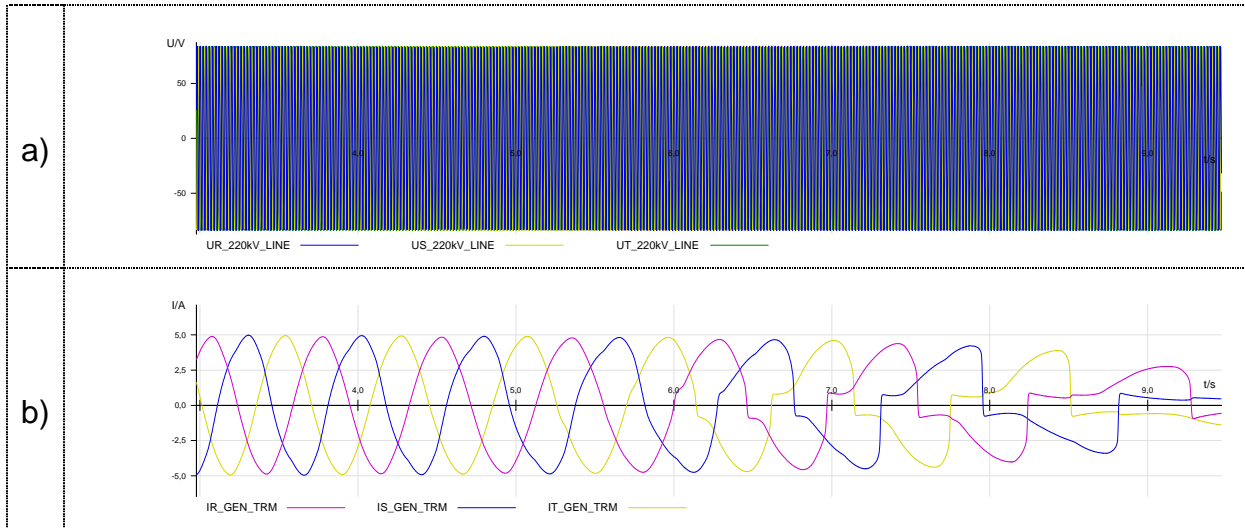

Fig. 6: End of the electrical breaking in generator mode (stator current frequency around 1Hz)

In Figure 7 disturbance recording captured during synchronous start is shown when the excitation supply fails to transfer to the permanent supply source (taken from the machine terminals). As a consequence at full speed of rotation motor voltage is below 50% of the rated voltage (see Figure 7a). Due to such failures function 27SS was introduced in order to detect such operating condition. In this figure the following quantities are shown:

- a) RMS values of phase to phase voltages at synchronous machine terminals
- b) RMS values of currents at synchronous machine terminals
- c) Frequency at machine terminals
- d) Trip from 27SS function
- e) Trip from existing protection scheme

Operating experience with the 100% stator earth fault protection 59THD, based on the third harmonic differential measurement [2], is extremely good. Third harmonic voltages in the machine neutral point and at machine terminals have almost constant relationship irrespective of the actual operating mode and loading of the unit. Phasors of these two quantities are always in contra-phase. Variations of third harmonic levels are just marginal. Due to differential principle used such changes causes no problem to the protection security. In Figure 8, Figure 9 and Figure 10 the following quantities, captured during different operating mode of the unit, are shown:

- a) Third harmonic voltage waveforms in the machine neutral point and at machine terminals
- b) Active and reactive power (i.e. P & Q) at synchronous machine terminals in % of machine 315MVA rating

Load rejection incident was also captured by the protection relay built-in disturbance recorder. During an external fault a relay in existing electro-mechanical protection scheme maloperated and has disconnected the unit from the network at 70% load. This resulted in over-speed of the machine rotor which is clearly visible in the frequency estimated by the frequency tracking feature built-into the relay. Frequency reached value of approximately 62Hz corresponding to the actual machine over-speed of 124%.

**Actual Trends in Development of Power System Protection and Automation
30 May – 3 June 2011, Saint Petersburg**

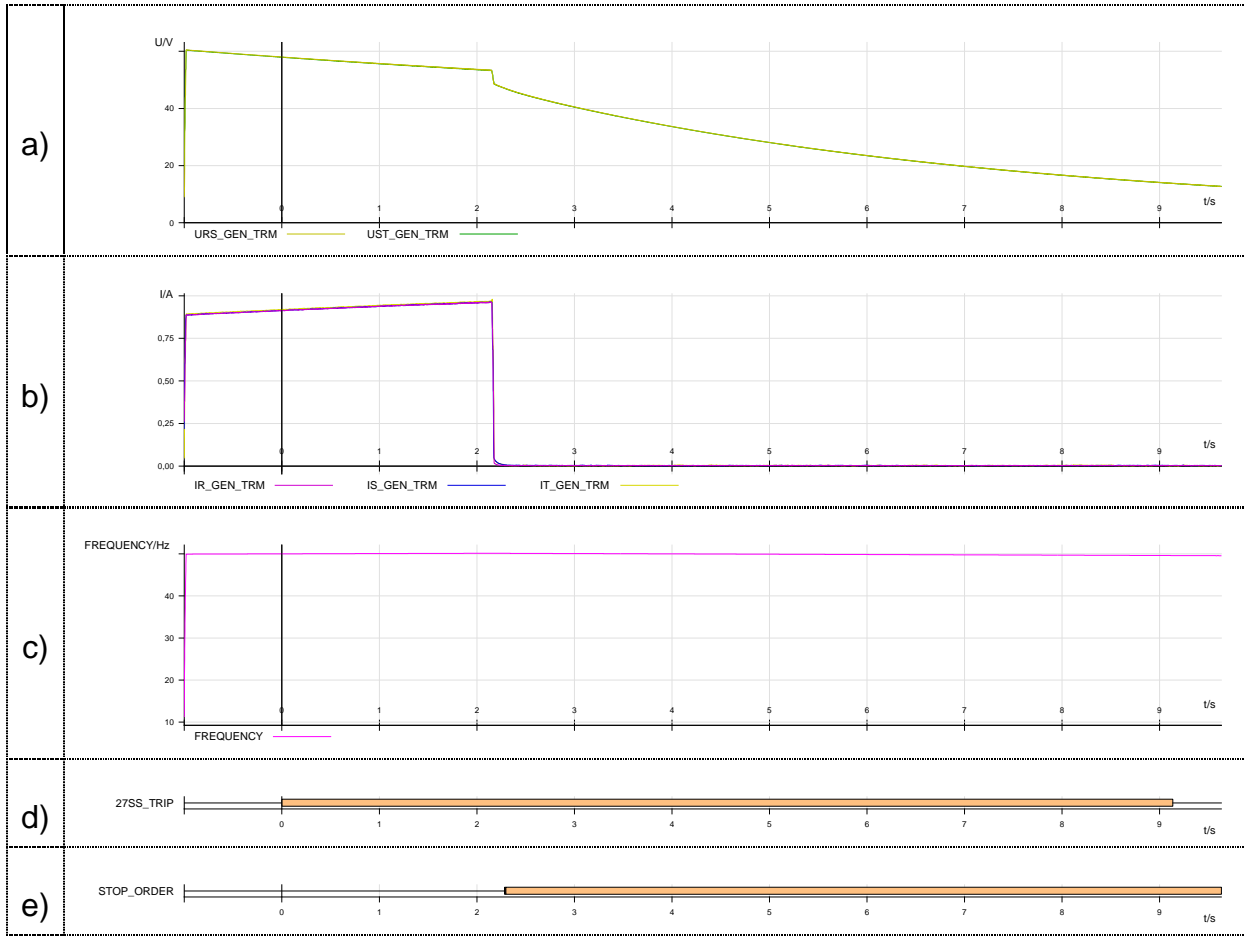

Fig. 7: Excitation supply failure during synchronous start

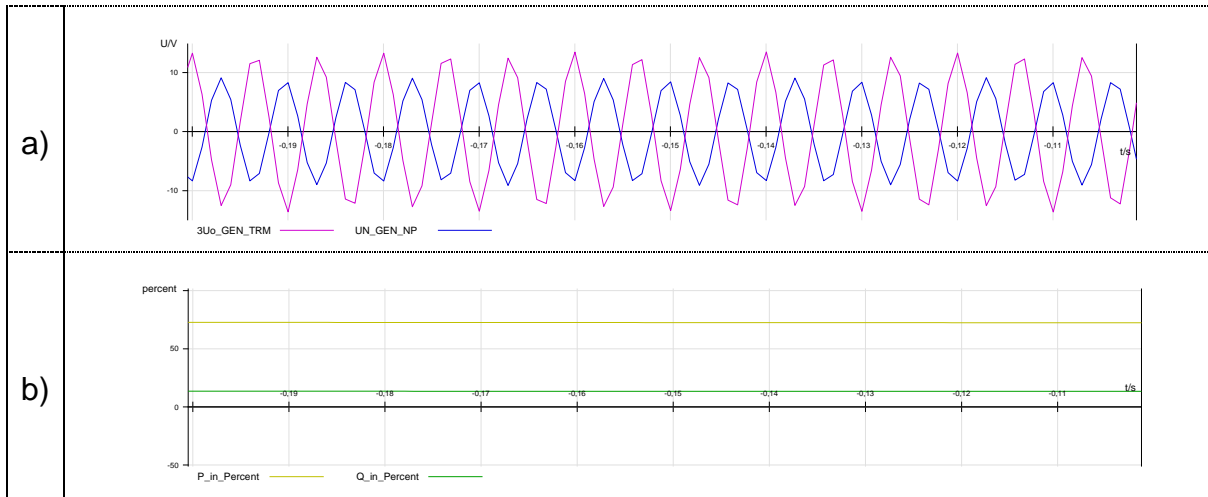
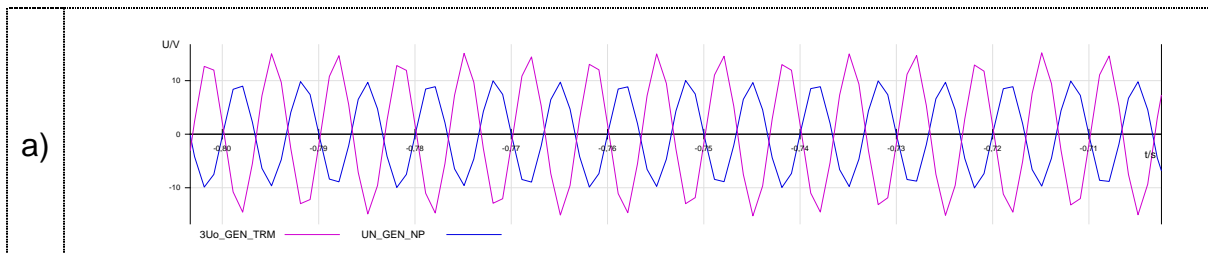

Fig. 8: Third harmonic voltages in generator mode (P=+72,6%, Q=+13,5%)



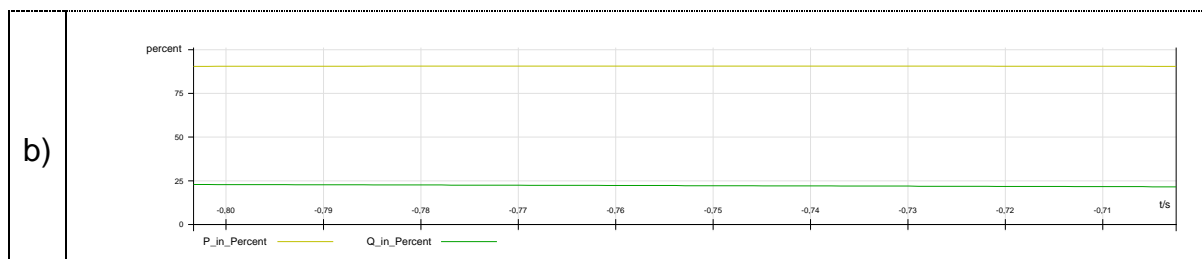

Fig. 9: Third harmonic voltages in generator mode (P=+90,6%, Q=+22,6%)

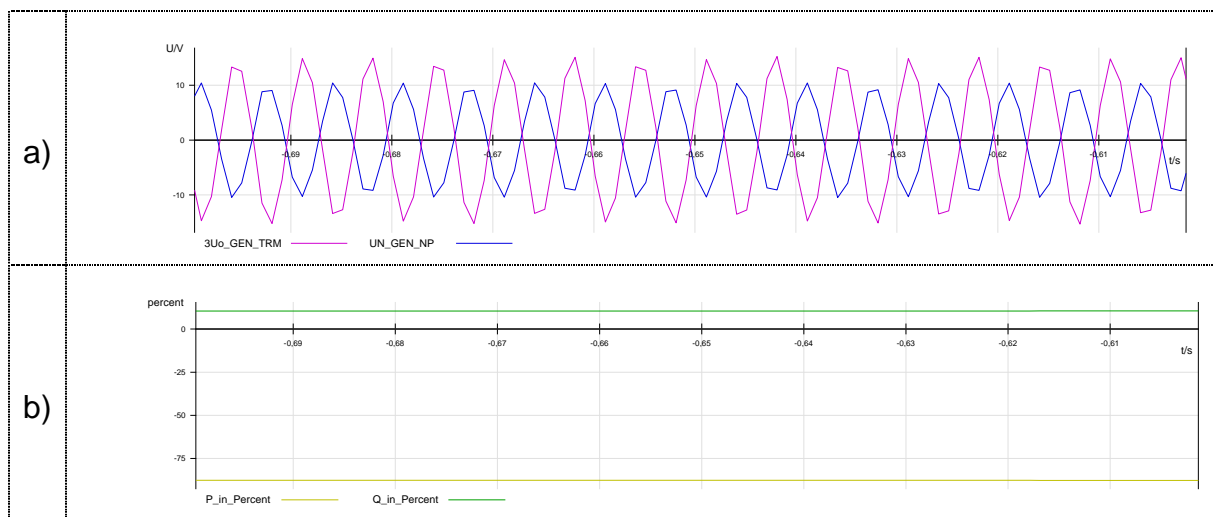

Fig. 10: Third harmonic voltages in pump mode (P=-87,6%, Q=+10,5%)

In Figure 11 the following quantities are shown:

- a) Frequency value estimated by the relay during load rejection
- b) Active and reactive power (i.e. P & Q) at synchronous machine terminals in % of machine 315MVA rating

Quite a few external faults in a 220kV network were captured by the protection relay built-in disturbance recorder. In Figure 12 one external fault in generator mode is presented, while in Figure 13 another external fault in pump mode is shown. The following quantities are shown in these figures:

- a) 220kV overhead line three phase current waveforms
- b) Three phase current waveforms at synchronous machine neutral point
- c) Active and reactive power (i.e. P & Q) at synchronous machine terminals in % of machine 315MVA rating

Operating experience with the injection based 100% stator earth fault protection 64S is extremely good. The protection is enabled under all operating modes of the machine. Back-to-back starting method does not pose any problems for the used injection equipment.

6 CONCLUSION

Bajina Bašta pump-storage plant is crucial for everyday operation of the Serbian power system. The two units are typically operated in the generator mode during the day and in the pump mode during the night. Thus, integrity of the protection scheme for these two units is essential.

The new protection relays are still under trial operation, which means that the tripping contacts are not connected, but relay performance is completely satisfactory. It is currently plan to connect tripping outputs from the scheme during unit maintenance period planned for summer 2011. Although it is a very complex application it has been possible to integrate all necessary functionalities for all operating modes in one single IED. The next step would be to install the second identical IED (Main 2) in order to obtain redundancy and then completely decommission the old electromechanical protection scheme.

**Actual Trends in Development of Power System Protection and Automation
30 May – 3 June 2011, Saint Petersburg**

The DC supply of the Main 2 IED will be separated from the supply of the Main 1 IED. The analog current and voltage signals to the Main 1 and Main 2 will also be separated by using different CT cores and VT secondary groups and cables. In this particular pump-storage plant the back up of the circuit breaker is solved by having two circuit breakers in series. The dependability requirement and the single-failure criterion will be fulfilled by using a second main protection system. Due to the high degree of functional integration the complete protection system with one Main 1 and one Main 2 can be realized in only two IEDs. This will also result in a protection system with high security.

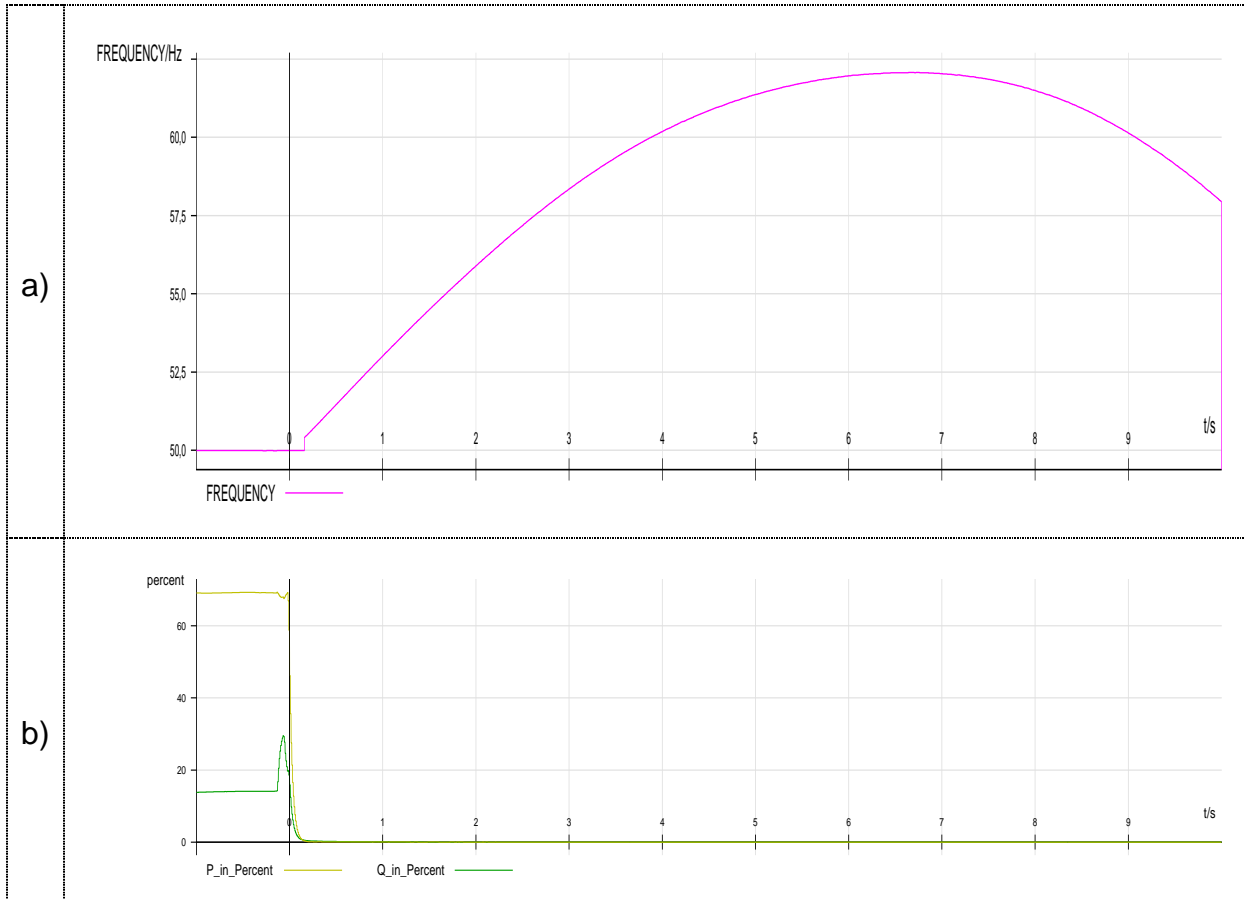
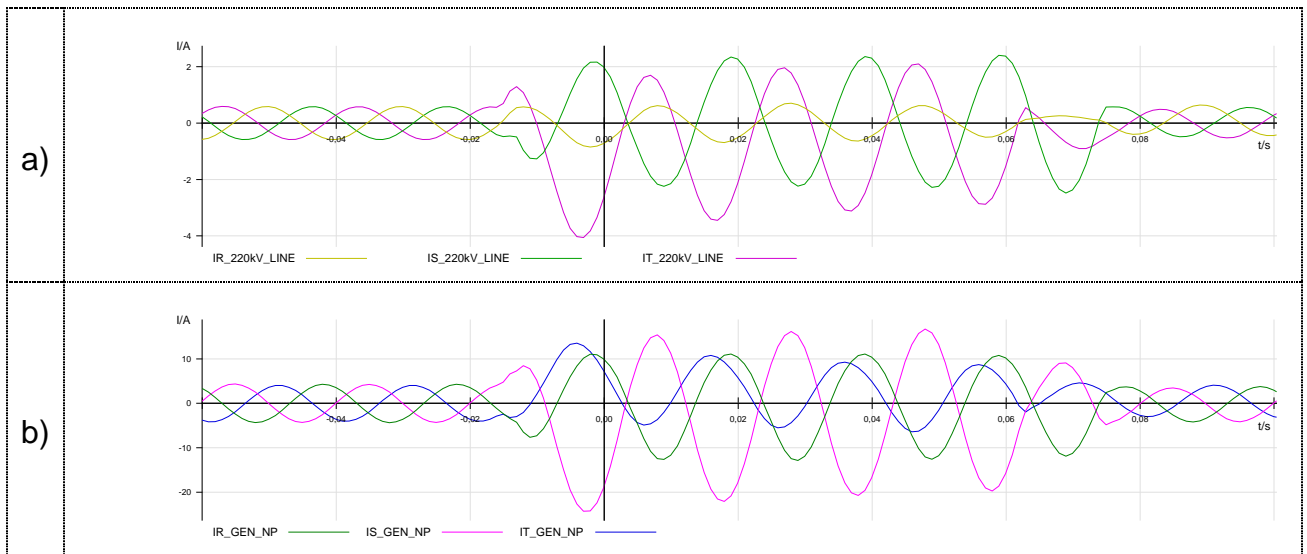

Fig. 11: Load rejection in generator mode ($P=+73\%$, $Q=+15\%$ just before the incident)



Actual Trends in Development of Power System Protection and Automation
30 May – 3 June 2011, Saint Petersburg

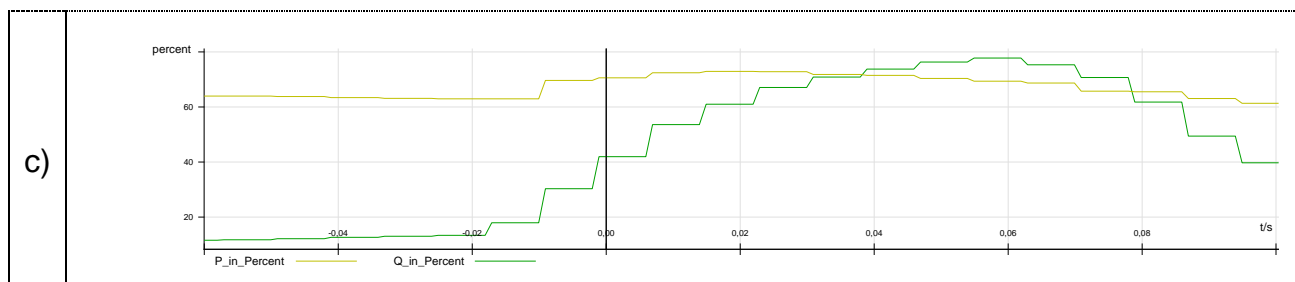

Fig. 12: External fault in generator mode ($P=+63.9\%$, $Q=+11.8\%$ before the fault)

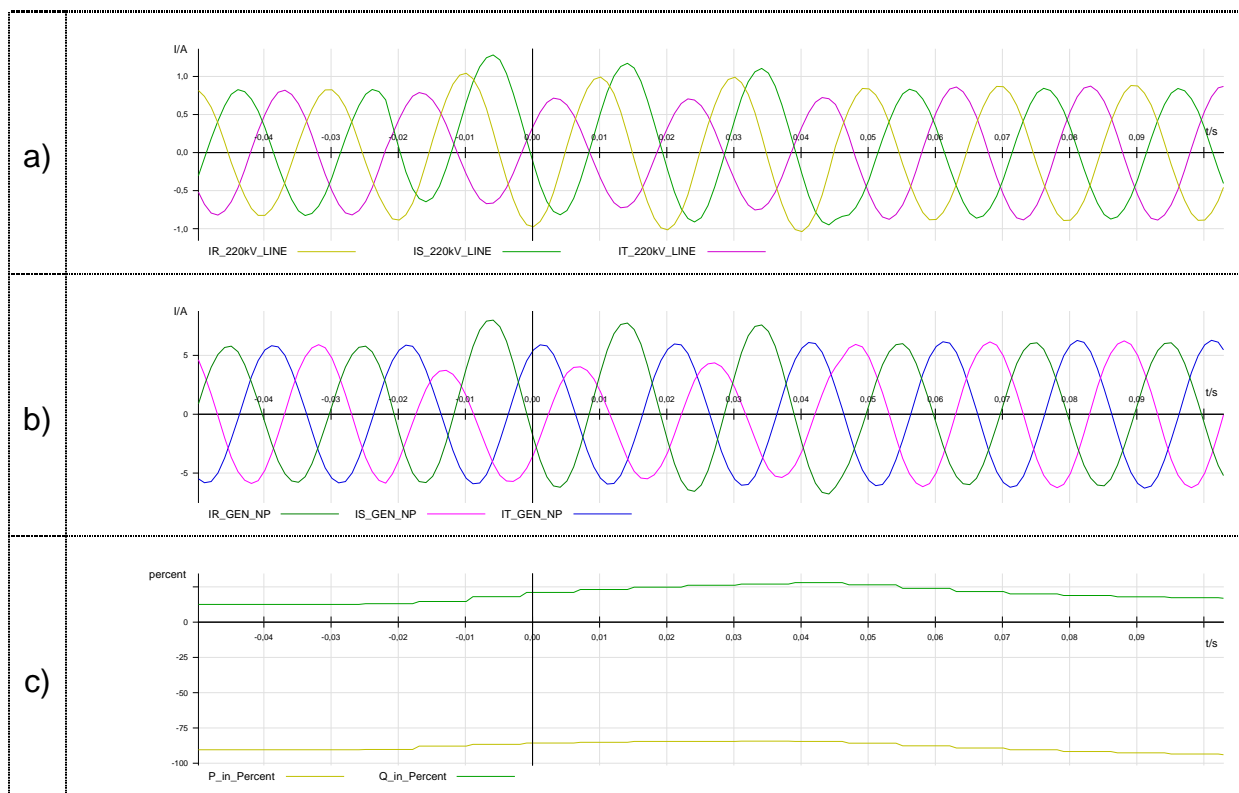

Fig. 13: External fault in pump mode ($P=-90.5\%$, $Q=+12.5\%$ before the fault)

REFERENCES

- [1] ABB. “Generator Protection IED REG670, Technical Reference Manual”, 1MRK502013-UEN, (2007).
- [2] I. Brnčić, Z. Gajić, S. Roxenborg, T. Bengtsson. “Adaptive 100% stator earth fault protection based on third harmonic voltage measurement”, International Conference on Relay Protection and Substation Automation of Modern EHV Power Systems, Moscow – Cheboksary, Russia, (2007).
- [3] Z. Gajić. “REG670 Installation in RHE Bajina Bašta”, ABB Doc. No. 1MRG000228, (2009).
- [4] Z. Gajić. “Test Report for REG 670 installed on GM1 unit in RHE Bajina Bašta”, ABB Doc. No. 1MRG000235, (2009).
- [5] IEEE PSRC. “Protective relaying for pumped storage hydro units rotating machinery protection subcommittee of the IEEE power system relaying committee”, Transaction on Power Apparatus and Systems, volume 94, pp. 899-907, (1975).
- [6] IEEE PSRC. “IEEE Guide for AC Generator Protection”, IEEE Std C37.102™-2006 .
- [7] M. Stien. “Generator Protection Application Guide”, ASEA, A03-0211E, (1983).
- [8] S. Holst, et al. “Functional Integration – Possibilities and Challenges”, Cigré SC B5 Colloquium in Madrid, Spain, (2007)
- [9] Cigré Brochure No 404, “Acceptable Functional Integration in HV Substations”, WG B5.13, (2010)