

Installation and commissioning manual

RXHL 401 and RAHL 401

Compact current relay and protection assemblies



About this manual

DocID: 1MRK 509 065-UEN

Issue date: February 2000

Status: New

Revision: Initial version

© ABB Automation Products AB 2000
Substation Automation Division

COPYRIGHT

WE RESERVE ALL RIGHTS TO THIS DOCUMENT, EVEN IN THE EVENT THAT A PATENT IS ISSUED AND A DIFFERENT COMMERCIAL PROPRIETARY RIGHT IS REGISTERED. IMPROPER USE, IN PARTICULAR REPRODUCTION AND DISSEMINATION TO THIRD PARTIES, IS NOT PERMITTED.

THIS DOCUMENT HAS BEEN CAREFULLY CHECKED. IF THE USER NEVERTHELESS DETECTS ANY ERRORS, HE IS ASKED TO NOTIFY US AS SOON AS POSSIBLE.

THE DATA CONTAINED IN THIS MANUAL IS INTENDED SOLELY FOR THE PRODUCT DESCRIPTION AND IS NOT TO BE DEEMED TO BE A STATEMENT OF GUARANTEED PROPERTIES. IN THE INTERESTS OF OUR CUSTOMERS, WE CONSTANTLY SEEK TO ENSURE THAT OUR PRODUCTS ARE DEVELOPED TO THE LATEST TECHNOLOGICAL STANDARDS. AS A RESULT, IT IS POSSIBLE THAT THERE MAY BE SOME DIFFERENCES BETWEEN THE HW/SW PRODUCT AND THIS INFORMATION PRODUCT.

Manufacturer:

ABB Automation Products AB
Substation Automation Division
Dept. TC
SE-721 59 Västerås
Sweden
Tel: +46 (0) 21 34 20 00
Fax: +46 (0) 21 14 69 18
Internet: <http://www.abb.se>

Chapter	Page
Chapter 1 Introduction	1
Introduction to the installation and commissioning manual	2
About this manual	2
Intended audience	2
Related documents	3
Revision notes	3
Chapter 2 Safety information	5
Safety signs	6
Description of safety signs	6
Warning signs	6
Note signs	7
Chapter 3 Installation	9
Overview	10
Preparations	11
Receiving, unpacking and checking	11
Storage	11
Mechanical installation	12
Electrical installation	14
Chapter 4 Commissioning	17
Overview	18
Preparations	19
Checking the external connections	20
Checking the CT circuits	20
Checking the auxiliary voltage circuits	20
Checking the binary input circuits	21
Checking the binary output circuits	21
Checking the trip circuits and circuit-breakers	21
Retrieving general relay data	22
Setting the general relay parameters	23
Selecting HMI language	23
Changing the HMI appearance	23
Setting the basic protection parameters	25
Setting the rated system frequency	25
Setting the main CT Ratio	25
Selecting active group	26
Setting the protection function parameters	28
Overcurrent protection	28

Earth-fault protection	29
Configuring the relay	31
Configure the binary input and output signals	31
Secondary injection testing	34
Overview	34
Testing the second setting group.....	35
Checking the trip circuits.....	35
Overcurrent protection	35
Earth-fault protection	36

Chapter 5 Operations during commissioning and maintenance . 39

Overview	40
Using the service values menu	41
Reading service values.....	41
Service values menu	42
Using the indications menu.....	43
Reading disturbance information	43
Indications menu.....	44

Chapter 6 Maintenance..... 47

Overview	48
Preventive maintenance	49
Checking the disturbance information	49
Performing a start-up check.....	49
Checking the service values	49
Testing the binary inputs.....	49
Testing the binary outputs	49
Dressing burned contacts on the auxiliary tripping relays	49
Performing additional tests	49
Corrective maintenance	50
Check the green “in service” LED on RXTUG 22H.....	50
Check the green “in service” LED on the measuring relay	50
Check the indications.....	50

Chapter 7 Protection assemblies and diagrams..... 53

Compact current protection assembly RAHL.....	54
Protection assemblies.....	56
Mounting alternatives.....	57
Terminal and circuit diagrams.....	58

Chapter 8 Test records..... 63

Compact current relay RXHL 401	64
Service value	65

Overcurrent protection	66
Protection settings	66
Protection configurations	66
Operate and reset values	67
Time measurements	67
Functional check.....	68
Earth-fault protection	69
Protection settings	69
Protection configurations	69
Operate and reset values	70
Time measurements	70
Functional check.....	71

Chapter 1 Introduction

About this chapter

This chapter introduces the user to the content in the manual. The intended use of the manual and the intended audience is described. The introduction chapter also contains references to other documents.

1 Introduction to the installation and commissioning manual

1.1 About this manual

This manual contains instructions on how to install, commission and maintain the compact current relay and protection assemblies. The manual covers procedures for mechanical and electrical installation, setting and configuration, secondary injection testing, preventive and corrective maintenance. The chapters and sections are organised in the chronological order the protection should be installed and commissioned.

The installation and commissioning manual contains the following chapters:

- The *safety information* chapter presents warning and note signs, which the user should draw attention to.
- The *installation* chapter contains instructions on how to install the protection.
- The *commissioning* chapter contains instructions on how to commission the protection.
- The *operations during commissioning and maintenance* chapter contains instructions on frequently performed operations during commissioning and maintenance, such as reading off primary and secondary service values and disturbance information.
- The *maintenance* chapter contains instructions on how to maintain the protection.
- The *protection assemblies and diagrams* chapter contains descriptions over the protection and assembly variants.
- The *test records* chapter contains test records which could be used for documentation purposes.

1.2 Intended audience

1.2.1 General

The installation and commissioning manual is addressing the installation, commissioning and maintenance personnel responsible for taking the protection into normal service and out of service.

1.2.2 Requirements

The installation personnel must have a basic knowledge in using protection equipment. The commissioning and maintenance personnel must be well experienced in using protection equipment, protection functions and the configured functional logics in the protection.

1.3

Related documents

Document related to COMBIFLEX[®] assemblies	Identity number
Buyer's guide, Connection and installation components in COMBIFLEX [®]	1MRK 513 003-BEN
Buyer's guide, Relay accessories and components	1MRK 513 004-BEN
Buyer's guide, Test system COMBITEST	1MRK 512 001-BEN
Buyer's guide, DC-DC converter	1MRK 513 001-BEN
Buyer's guide, Auxiliary relays	1MRK 508 015-BEN

Documents related to RXHL 401 and RAHL 401	Identity number
Technical overview brochure	1MRK 509 062-BEN
Connection and setting guide (only RXHL 401)	1MRK 509 062-WEN
Operator's manual	1MRK 509 063-UEN
Technical reference manual	1MRK 509 064-UEN
Installation and commissioning manual	1MRK 509 065-UEN

1.4

Revision notes

Revision	Description
-	Initial version

Chapter 2 Safety information

About this chapter

This chapter contains safety information. Warning and note signs are presented which attend the user to be careful during certain operations in order to avoid human injuries or damage to equipment.

1 Safety signs

1.1 Description of safety signs

1.1.1 The warning sign

The warning sign informs the user that certain operations should be avoided in order to prevent human injuries or damage to equipment.

1.1.2 The note sign

The note sign informs the user to be careful when using the product in certain situations and notifies the user to facts that could be of special interest during certain operations.

1.2 Warning signs



Warning!

Never plug or withdraw a relay from the terminal base without blocking the output circuits or interrupting the auxiliary DC supply. Otherwise there is a risk of unwanted operations.



Warning!

Always avoid to touch the circuitry when the plastic cover, which covers the relay, is removed. The product contains electronic circuitries which can be damaged if exposed to static electricity (ESD). The electronic circuitries also contain high voltage which is lethal to humans.



Warning!

Never disconnect a wire in a current circuit. Always be sure to short-circuit the secondary phase terminals of the current transformers to neutral before the circuit is opened. An opened current circuit will produce an extremely high voltage which is lethal to humans.

1.3

Note signs

**Note!**

The protection assembly is designed for a maximum continuous current of four times rated value.

**Note!**

The length of the EMC-cable must be as short as possible when connecting to EMC-earth. Withstand against electrical disturbances could otherwise be hazarded.

**Note!**

If the LED's are flashing or the green 'In service' LED is dark, an internal fault has occurred. Read the self supervision section in the technical reference manual for further information.

Chapter 3 Installation

About this chapter

This chapter contains instructions on how the protection should be installed regarding mechanical and electrical installation. The different instruction sections in this chapter are organized in the order the installation work should be performed.

1

Overview

Before you can start the installation work you must be aware of the application of the protection assembly.

The mechanical and electrical environmental conditions at the installation site must be within the permissible range according to at the data sheets of the protection assembly. Dusty, damp places, places liable to rapid temperature variations, powerful vibrations and shocks, surge voltages of high amplitude and fast rise time, strong induced magnetic fields or similar extreme conditions should be avoided.

Sufficient space must be available in front of and at rear of the protection assembly to allow access for maintenance and future modifications.

When the instructions in this chapter are covered the protection assembly will be ready for commissioning as described in the commissioning chapter.

The installation work starts with unpacking and checking that the items included are according to delivery documents. The mechanical installation includes plugging the relay into a terminal base, which should be fixed on an apparatus bar. The protection assembly is then mounted into a case. The electrical installation means connecting the cables from the transformers, binary I/O and auxiliary voltage.



Warning!

Always avoid to touch the circuitry when the plastic cover, which covers the relay, is removed. The product contains electronic circuitries which can be damaged if exposed to static electricity (ESD). The electronic circuitries also contain high voltage which is lethal to humans.

2 Preparations

2.1 Receiving, unpacking and checking

Procedure

1. **Remove the protection package from the transport case and perform a visual inspection of any possible transport damages.**
2. **Check that all units are included in accordance with the delivery documents.**

In case of transport damages, appropriate action must be taken against the last carrier and the nearest ABB office or agent should be informed. ABB should be notified immediately if there are any discrepancies in relation to the delivery documents.

3. **Check that the protection assembly has the correct identity markings on the front.**

The check should confirm that the terminal type, markings and serial number corresponds to what has been ordered.

4. **Check that all screws are firmly tightened and all relay elements are securely fastened.**

2.2 Storage

If the protection must be stored before installation. This must be done in a dry and dust-free place, preferably in the original transport case.

3 Mechanical installation

This section contains instructions for the mechanical installation.

Before you can start the mechanical installation you must purchase terminal bases, apparatus bars and an appropriate case. These items are all needed when performing the mechanical installation.

The mechanical installation starts by fixing the terminal bases and the COMBITEST test switch, when included, on the apparatus bars. Then the COMBIFLEX[®] units are plugged into the COMBIFLEX[®] terminal bases. The protection assembly can then be mounted into a frame or case. The following frames and cases are available:

- 19" equipment frame.
- RHGX case.
- RHGS case.

See the technical reference manual for description over the available cases.

All internal protection connections are made and the protection assembly is tested before delivery from factory.



Note!

The length of the EMC-cable must be as short as possible when connecting to EMC-earth. Withstand against electrical disturbances could otherwise be hazarded.

Procedure

- 1. Fix the terminal bases on an apparatus bar to make up the protection assembly.**
- 2. Plug the COMBIFLEX[®] units into the terminal bases.**

Consult the circuit diagram to find out where the units should be plugged. The circuit diagram also gives the height and the width of the protection assembly.

- 3. Mount the protection assembly into a desired case.**

There are three available cases; RHGS 30, RHGX 8 and 19" equipment frames. The protection assembly is inserted and fastened with screws at the backplane of the case.

4. Connect EMC-earth connection on required units.

Connect one part of the EMC-cable at the backplane of the case with a screw, connect a 10 A COMBIFLEX socket on the other part and connect it into the terminal base.

4 Electrical installation

This section contains instructions for the electrical installation.

Before the user can start working the valid circuit diagrams must be available in order to decide how the connections should be made. See the chapter “Protection assemblies and diagrams”. The user must also have the COMBIFLEX[®] crimping tool and leads with 10 and 20 A COMBIFLEX[®] sockets available.

The wiring from the cubicle terminals to the COMBIFLEX[®] terminals on the rear side of the protection assembly must be made in accordance with the established guidelines for this type of equipment. The wires for binary inputs and outputs and the auxiliary supply should be laid separated from the current and voltage transformer cables between the cubicle terminals and the protection terminals.

The external connections to the COMBIFLEX[®] terminals of the protection assembly shall be made in accordance with the valid terminal diagram. The cables from the transformers should be identified with regards to phases and connected to the proper COMBIFLEX[®] terminals.

If the protection assembly is provided with a COMBITEST test switch, COMBIFLEX[®] wires are used for both internal and external connections. Connections to and from the test switch are made with leads with 20A COMBIFLEX[®] sockets. Leads for internal terminal bases with 10A COMBIFLEX[®] sockets.

Example

Figure 1 shows an example of the rear of a protection assembly with COMBITEST test switch. Terminal positions are used for internal and external connections.

Each unit in the protection assembly has a unique item designation. The item designations are based on the COMBIFLEX[®] coordinate system of U and C modules, where the first figure stands for the U module position starting from the top, and the next two figures stand for the C module position, starting from the left-hand side seen from the front side of the protection assembly.

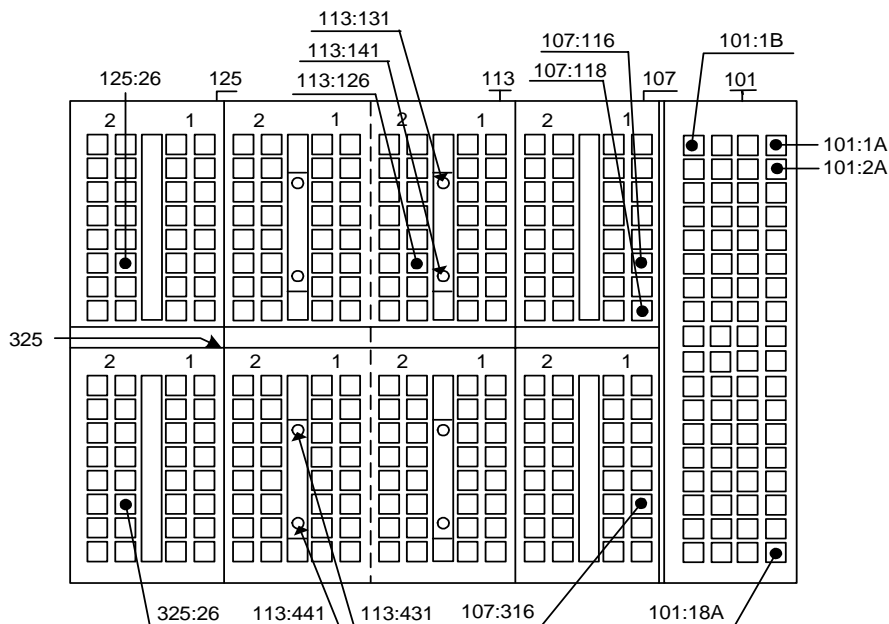

99000147.vsd

Figure 1: Terminal locations at the rear of a protection assembly.

Procedure

1. **Connect the RTXP test switch to the valid connector with 20 A sockets.**
2. **Connect the external connector to the terminal bases with 10 A sockets.**

See the chapter “Protection assemblies and diagrams” for valid terminal diagrams.

Chapter 4 Commissioning

About this chapter

This chapter contains instructions on how the commissioning of the protection is performed. That is checking external connections, setting and configuring the relay and secondary injection testing. The different instruction sections in this chapter are organized in the order the commissioning work should be performed.

1

Overview

The commissioning work starts by preparing the site for commissioning. A check of the external connections must then be carried out, which includes checking of external circuits and associated equipment, such as transformers, circuit-breakers and signalling equipment. The general relay parameters, the basic protection parameters and each protection function parameter have to be set. The binary I/O signals for the relay must also be configured. All settings must be made through the local human-machine-interface (HMI). Secondary injection testing of the protection assembly is made to verify that all protection functions operate in accordance with the relay setting plan. The commissioning work must also be properly documented for future reference. The test records available in this manual can be used.

The following diagram presents the major procedures during commissioning:

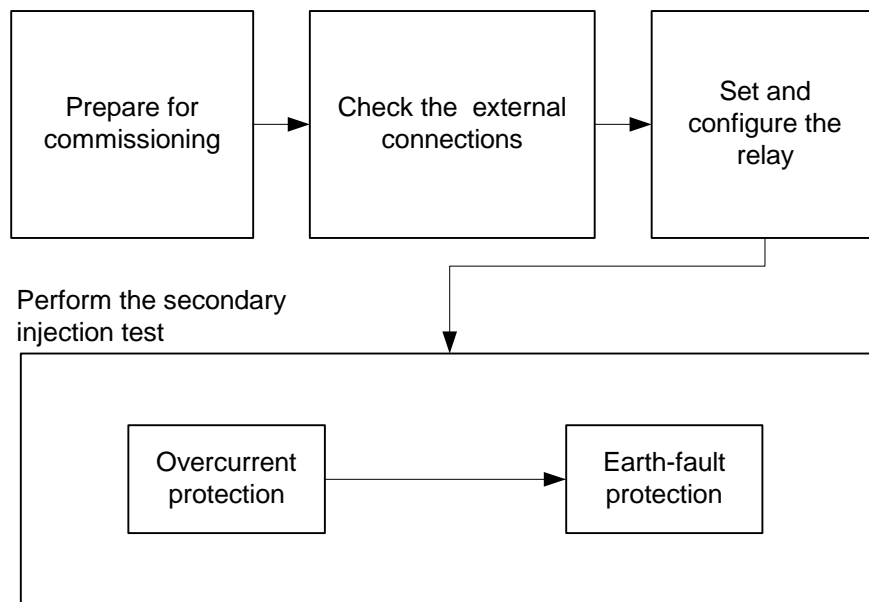

en00000016.vsd

Figure 2: Overview over the major procedures during commissioning.

2**Preparations**

Be sure that all necessary test equipment and documentation are available at site before the commissioning work is started up.

Necessary documentation and equipment for commissioning includes:

- Operator's manual if needed. The operator's manual includes general instructions on how to handle the human-machine-interface.
- Valid circuit diagrams and test records are available in this manual.
- Test equipment.

For secondary injection testing of the protection assembly a test equipment with a variable phase current and a time measuring function, also a multimeter or ammeter with class 0.5 or better is required. Test equipment SVERKER or similar is recommended.

3 Checking the external connections

3.1 Checking the CT circuits

The CT's must be connected in accordance with the circuit diagram provided with the protection assembly, both with regards to phases and polarity. The following tests are recommended:

- Primary injection test to verify the current ratio and the correct wiring up to the protection assembly for all current transformers and phases.
- Polarity check.
- Check of the ground connection of the CT circuits.
- Verification of data for the CT's.

CT circuits must be properly connected to the station ground and only at one electrical point.

When core balanced CTs are used for measuring the earth-fault current the screen must be ground connected outside the transformer, as shown in figure 3.

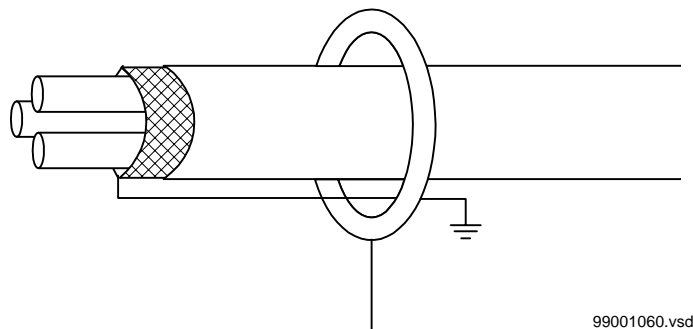

Figure 3: Core balanced CT

3.2 Checking the auxiliary voltage circuits

Check that the auxiliary voltage supplied to the DC/DC-converter is in accordance with the data for the protection assembly and that the voltage has correct polarity.

3.3 Checking the binary input circuits

The user can separately test the internal and external cable connections for the binary inputs via the 'Test' menu in the local HMI.

Check the connections to the digital inputs so that both input levels and polarity are in accordance with protection assembly specifications. Verify a binary input by energizing it and overview the status through the 'Test' menu.

Parameter	Let you...
BinIn: 12	Verify the binary input signal, the figure will be filled when the input is energized.

3.4 Checking the binary output circuits

The user can separately test the internal and external cable connections for the binary outputs via the 'Test' menu in the local HMI.

Check the connections to the digital outputs so that both output loads and polarity are in accordance with protection assembly specifications. Verify the function of a binary output signal by triggering the selected output in the 'Test' menu and overview the output contact status.

Parameter	Let you...
BinOut: 12345	Verify the triggering of selected output (relay) by pressing the E button.

3.5 Checking the trip circuits and circuit-breakers

The trip circuits are tested as part of the secondary injection test.

4 Retrieving general relay data

This section describes how the user can retrieve data about the relay, such as the article number, rated current and version number.

Procedure

1. Browse to the 'Information' menu.
2. Select one of the following information items.

Table 1: Information items about the relay

Information	Description
1MRK XXX XXX-XX	Article number, relay.
I _r : XA	Rated current.
IN _r : XA	Rated neutral current.
VerNo: X.X-X	Version number of the relay.
SerNo: PXXXXXX	Serial number of the relay.

3. Leave the menu by pushing the 'C' button.

5 Setting the general relay parameters

5.1 Selecting HMI language

This section describes how to change the language appearing on the local human-machine-interface (HMI).

You can change the language appearing on the local-HMI by using the 'Lang/Språk' menu.

Procedure

1. Browse to the 'Lang/Språk' menu.

The 'Lang/Språk' menu is available in the local HMI under:

Lang/Språk

2. Select language.

Table 2: Setting parameter, language

Parameter	Range	Unit	Default	Let you...
Language	English, Svenska	-	English	Select HMI language

3. Leave the menu and confirm your setting.

5.2 Changing the HMI appearance

This section describes how you can change the appearance of the display and the behavior of the LED's on the local human-machine-interface (HMI).

You can change the contrast and time-out for the display (30 min). You can also change function for the LED's.

5.2.1 Changing the appearance of the display

Procedure

1. Browse to the 'Display' menu.

The 'Display' menu is available in the local HMI under:

HMI

Display

2. Change the parameter value.

Use the left or right arrow-button to define a value. The following values have to be set:

Table 3: Setting parameter, contrast of the HMI

Parameter	Range	Unit	Default	Let you...
Contr	0 - 100	%	50 %	Select the display contrast, 0 - 100 %
Show	Limit/ Unlimit	-	Limit	Select display time-out limit (30 min) or unlimited

3. Leave the menu and confirm your settings.

5.2.2

Select function for the LED's

Procedure

1. Browse to the 'Indications' menu.

The 'Indications' menu is available in the local HMI under:

HMI

Indications

2. Change the parameter value.

Use the left or right arrow-button to define a value. The following values have to be set:

Table 4: Setting parameter, function of the LED's

Parameter	Range	Unit	Default	Let you...
Start	Remain, Return	-	Return	Select start LED to remain or not (return).
Trip	Remain, Return	-	Remain	Select trip LED to remain or not (return).

3. Leave the menu and confirm your settings.

6 Setting the basic protection parameters

6.1 Setting the rated system frequency

The rated frequency for the relay is set through the 'BasicSetting' menu in the local human-machine-interface (HMI).

Procedure

1. Browse to the 'Frequency' menu.

The 'Frequency' menu is available in the local HMI under:

Settings

BasicSetting

Frequency

2. Enter the rated frequency for the relay.

Table 5: Rated system frequency

Parameter	Range	Unit	Default	Let you...
Freq	50/60	Hz	50 Hz	Select the rated frequency.

3. Leave the menu and confirm your setting.

6.2 Setting the main CT Ratio

The current ratio of the main CT's for all phases and neutral are set through the 'Basic-Setting' menu in the local human-machine-interface (HMI).

Procedure

1. Browse to the 'MainCTRatio' menu.

The main CT ratio for the 'Phase' and 'EarthFault' transformers is available in the local HMI under:

Settings**BasicSetting****MainCTRatio****Phase****EarthFault**

2. Enter the primary and secondary current values of the main CT's.

Table 6: Main CT Ratio

Parameter	Range	Unit	Default	Let you...
Primary	1.00 - 999	A	1.00 A	Select the primary rated value of the phase CT's and the earth-fault CT
	1.00 - 100	kA	-	
Secondary	0.40 - 10.0	A	1.00 A	Select the secondary rated value of the phase CT's and the earth-fault CT

3. Leave the menu and confirm your setting.

6.3**Selecting active group**

Active setting group for the relay is set through the 'ActiveGroup' menu in the local human-machine-interface (HMI).

Procedure

1. Browse to the 'ActiveGroup' menu.

The 'ActiveGroup' menu is available in the local HMI under:

Settings**ActiveGroup**

2. Select which group to be active.

Table 7: Setting parameters, active setting group

Parameter	Range	Unit	Default	Let you...
Active group	Group1, Group2	-	Group1	Select active group 1 or group 2 ^{a)}

a) Default settings for setting group 2 are the same as for group 1.

- 3. Leave the menu and confirm your setting.**

7 Setting the protection function parameters

7.1 Overcurrent protection

The setting parameter values for the overcurrent protection are set through the 'Over-Current' menu in the local human-machine-interface (HMI).

Procedure

1. Browse to the 'OverCurrent' menu.

The 'OverCurrent' menu is available in the local HMI under:

Settings

Functions

Group1

OverCurrent

2. Enter a value for each parameter.

Use the left or right arrow-button to define a parameter value. The following values have to be set:

Table 8: Setting parameters for overcurrent protection

Parameter	Range	Unit	Default	Let you...
I>	On - Off	-	On	Select low set stage I> to be active or not.
I>	0.2 - 3.0 x I _r	A	0.2 x I _r	Set operate level.
Char	NI, VI, EI, LI, RI, Def	-	Def	Select time characteristic, inverse or definite time.
KValue	0.05 - 1.10	-	-	Set time multiplier for inverse time function.
MinTime	0.00 - 2.00	s	-	Set minimum definite time delay for inverse time characteristic.
Time	0.00 - 20.0	s	0.00 s	Set definite time delay.
ResetT	0.00 - 500	s	0.00 s	Set linear reset time on I>.
I>>	On - Off	-	On	Select medium set stage I>> to be active or not.
I>>	1.0 - 20 x I>	A	1.0 x I>	Set operate level.

Parameter	Range	Unit	Default	Let you...
Time	0.00 - 20.0	s	0.00 s	Set definite time delay.
I>>>	On - Off	-	On	Select high set stage I>>> to be active or not.
I>>>	1.0 - 20 x I>	A	1.0 x I>	Set operate level.
Time	0.00 - 20.0	s	0.00 s	Set definite time delay.

3. Leave the menu and confirm your settings.

You can choose the active group for which the settings should be valid. Use the up- or down-arrow button to select active group.

7.2

Earth-fault protection

The setting parameter values for the earth-fault protection are set through the 'Earth-fault' menu in the local human-machine-interface (HMI).

Procedure

1. Browse to the 'EarthFault' menu.

The 'EarthFault' menu is available in the local HMI under:

Settings
Functions
Group1
EarthFault

2. Enter a value for each parameter.

Use the left or right arrow-button to define a value. The following parameter values have to be set:

Table 9: Setting parameters for earth-fault protection

Parameter	Range	Unit	Default	Let you...
I _{N>}	On - Off	-	On	Select low set stage I _{N>} to be active or not.
I _{N>}	0.1 - 2.5 x I _{Nr}	A	0.1 x I _{Nr}	Set operate level.
Char	NI, VI, EI, LI, RI, Log, Def	-	Def	Select time characteristic, inverse, logarithmic or definite time.

Parameter	Range	Unit	Default	Let you...
KValue	0.05 - 1.10	-	-	Set time multiplier for inverse time function.
	1.00 - 4.00	-	-	Set operate constant for logarithmic time function.
MinTime	0.00 - 2.00	s	-	Set minimum definite time delay for inverse time function.
	1.00 - 2.00	s	-	Set minimum definite time delay for logarithmic time function.
Time	0.00 - 20.0	s	0.00 s	Set definite time delay.
ResetT	0.00 - 500	s	0.00 s	Set linear reset time on $I_{N>}$.
$I_{N>>}$	On - Off	-	On	Select medium set stage $I_{N>>}$ to be active or not.
$I_{N>>}$	1.0 - 20 x $I_{N>}$	A	1.0 x $I_{N>}$	Set operate level.
Time	0.00 - 20.0	s	0.00 s	Set definite time delay.
$I_{N>>>}$	On - Off	-	On	Select high set stage $I_{N>>>}$ to be active or not.
$I_{N>>>}$	1.0 - 20 x $I_{N>}$	A	1.0 x $I_{N>}$	Set operate level.
Time	0.00 - 20.0	s	0.00 s	Set definite time delay.

3. Leave the menu and confirm your setting.

You can choose the active group for which the setting should be valid. Use the up- or down-arrow-button to select active group.

8 Configuring the relay

8.1 Configure the binary input and output signals

This section describes how the configuration menu is used when configuring the parameters for the binary input and output signals.

8.1.1 Binary input signals

Procedure

1. Browse to the 'BinaryInputs' menu.

The 'BinaryInputs' menu is available in the local HMI under:

Configuration
BinaryInputs

2. Select binary input for function signals.

Use the left or right arrow button to mark a binary input.

Table 10: Input signals, overcurrent protection

Signal	Default	Description
I> Block/Enable	-	Active signal blocks or enables the low set overcurrent stage I>
I>> Block/Enable	-	Active signal blocks or enables the medium set overcurrent stage I>>
I>>> Block/Enable	-	Active signal blocks or enables the high set overcurrent stage I>>>

Table 11: Input signals, earth-fault protection

Signal	Default	Description
I _N > Block/Enable	-	Active signal blocks or enables the low set earth-fault stage I _N >
I _N >> Block/Enable	-	Active signal blocks or enables the medium set earth-fault stage I _N >>
I _N >>> Block/Enable	-	Active signal blocks or enables the high set earth-fault stage I _N >>>

Table 12: Input signal, indications

Signal	Default	Description
ResetLED	-	Active signal resets LED's, clears recorded disturbances and trip values

Table 13: Input signal, active setting group

Signal	Default	Description
ChActGrp	-	Active signal changes active setting group

3. Leave the menu and confirm your settings.

8.1.2

Binary output signals

Procedure

1. Browse to the 'BinaryOutputs' menu.

The 'BinaryOutputs' menu is available in the local HMI under:

Configuration

BinaryOutputs

2. Select binary output for function signals.

Use the left or right arrow-button to mark a binary output.

Table 14: Output signals, overcurrent protection

Signal	Default	Description
I>St	Relay 1	Start signal from low set overcurrent stage I>
I>Tr	Relay 2	Trip signal from low set overcurrent stage I>
I>>St	Relay 1	Start signal from medium set overcurrent stage I>>
I>>Tr	Relay 2	Trip signal from medium set overcurrent stage I>>
I>>>St	Relay 1	Start signal from high set overcurrent stage I>>>
I>>>Tr	Relay 2	Trip signal from high set overcurrent stage I>>>

Table 15: Output signals, earth-fault protection

Signal	Default	Description
$I_{N>St}$	Relay 1	Start signal from low set earth-fault stage $I_{N>}$
$I_{N>Tr}$	Relay 2	Trip signal from low set earth-fault stage $I_{N>}$
$I_{N>>St}$	Relay 1	Start signal from medium set earth-fault stage $I_{N>>}$
$I_{N>>Tr}$	Relay 2	Trip signal from medium set earth-fault stage $I_{N>>}$
$I_{N>>>St}$	Relay 1	Start signal from high set earth-fault stage $I_{N>>>}$
$I_{N>>>Tr}$	Relay 2	Trip signal from high set earth-fault stage $I_{N>>>}$

Table 16: Output signal, active setting group

Signal	Default	Description
Group2Act	-	Active signal when Group2 is selected

Table 17: Output signal, self-supervision function

Signal	Default	Description
InService	Relay 5	Active signal when relay is in normal service

3. Leave the menu and confirm your settings.

9 Secondary injection testing

9.1 Overview

The testing requires a good understanding of the protection functions and the configured functional logic in the relay. The relay must be properly set and configured according to previous sections before any of these instructions could be carried out. The plastic cover which covers the relay must also be removed.

Secondary injection testing is a normal part of the commissioning work. The operating values for all protection functions, the output to the proper trip and alarm contacts and the operation of digital input signals are checked and documented for future reference. The test records available in this manual can be used. See the chapter “Test records”.

The connection of the test set to the protection assembly is greatly simplified if the RTXP 18 test switch is included. When the test handle RTXH 18 is inserted in the test switch, preparations for testing are automatically carried out in the proper sequence, that is blocking of the tripping circuits, short-circuiting of the current circuits on the transformer side, opening of the current transformer circuits and making relay accessible from the terminals on the test plug handle.

If the protection assembly is not provided with a test switch the protection must be tested via the external circuit terminals. Make sure that the instrument transformers are isolated from the circuits connected to the test set.

A secondary test instruction is given for each type of protection function. The testing is performed in a sequence which secures that the blocked stage is released and tested. Blocking and releasing of stages are made in the setting menu and can be done in the local human-machine-interface (HMI).

Blocking or release of protection functions from digital input(s) shall, when included, be checked as a part of the secondary testing of the individual protection functions.



Warning!

Never plug or withdraw a relay from the terminal base without blocking the output circuits or interrupting the auxiliary DC supply. Otherwise there is a risk of unwanted operations.

**Note!**

The protection assembly is designed for a maximum continuous current of four times rated value.

9.2 Testing the second setting group

Secondary testing of all functions in one setting group should be performed before starting to test the other group.

9.3 Checking the trip circuits

Check that the circuit-breakers of the protective object operates when the tripping relays are activated. The trip relays are conveniently activated by secondary injection to activate a suitable protection function.

9.4 Overcurrent protection**Procedure**

1. **Connect the test set for injection of a current in phase IL1.**
2. **Increase the current in phase IL1 until the low set stage operates.**
3. **Decrease the current slowly and note the reset value.**
4. **Block medium and high set stages ($I_{>>}$ and $I_{>>>}$) if the injected current will activate the medium and high set stages when testing the low set stage according to below.**
5. **Connect a trip output contact to the timer.**
6. **Set the current to 130% of the operate value for the low set stage, switch on the current and check the time delay.**

For inverse time curves, check the operate time at a current equal to 200% of the operate current.

7. **Check that start and trip contacts operate according to the configuration logic.**
8. **Check the indications menu which is provided with information about operated functions and also the stored primary trip currents.**

Check that no unwanted operations have occurred.

9. Check in the same way the function for the other phases (step 1-8 above).
10. Block $I_{>}$ and release the blocking of the medium set stage ($I_{>>}$).
11. Check the operate and reset value and the time delay for the medium set stage in the same way as for the low set stage (step 1-9 above).
12. Check in the same way the function of the high set stage ($I_{>>>}$) when $I_{>}$ and $I_{>>}$ are blocked (step 1-9 above).
13. Release the blocking of the low and medium stage according to configuration logic.

9.5

Earth-fault protection

Procedure

1. Connect the test set for injection of a current in I_N .
2. Increase the current in I_N until the low set stage operates.
3. Decrease the current slowly and note the reset value.
4. Block medium and high set stages ($I_{N>>}$ and $I_{N>>>}$) if the injected current will activate the medium and high set stages when testing the low set stage according to below.
5. Connect a trip output contact to the timer.
6. Set the current to 130% of the operate value for the low set stage, switch on the current and check the time delay.
For inverse time curves, check the operate time at a current equal to 200% of the operate current.
7. Check that start and trip contacts operate according to the configuration logic.
8. Check the indications menu which is provided with information about operated functions and also the stored primary trip currents.
Check that no unwanted operations have occurred.
9. Block $I_{N>}$ and release the blocking of the medium set stage ($I_{N>>}$).
10. Check the operate and reset value and the time delay for the medium set stage in the same way as for the low set stage (step 2-8 above).
11. Check in the same way the function of the high set stage ($I_{N>>>}$) when $I_{N>}$ and $I_{N>>}$ are blocked (step 2-8 above).

12. Release the blocking of the low and medium set stage according to the configuration logic.

Chapter 5 Operations during commissioning and maintenance

About this chapter

This chapter contains instructions on operations during commissioning and maintenance, such as reading off service values and disturbance information.

1**Overview**

The relay must be properly set and configured according to previous chapters before any of these instructions could be carried out. The plastic cover which covers the relay must also be removed.

The operations during commissioning and maintenance involve reading off service values, function status and recorded disturbances caused by current injections provided from test equipment.

2 Using the service values menu

2.1 Reading service values

This section describes how to read primary and secondary service values and how to use the service value menu during commissioning and maintenance of the relay.

Press any button except the 'C' button to view the main menu. If the 'C' button is pressed and a disturbance has been recorded the indication menu will be presented.

2.1.1 Primary service values

Procedure

1. **Browse to the 'Primary' menu from the main menu.**

The 'Primary' menu is available in the local HMI under:

ServiceValues

Primary

2. **Choose 'Primary' menu and then press the 'E' button.**

The display will present the first set of service values.

3. **Press any button on the local HMI to present the second set of service values.**
4. **Press any button on the local HMI to return to the 'Primary' menu.**

2.1.2 Secondary service values

Procedure

1. **Browse to the 'Secondary' menu from the main menu.**

The 'Secondary' menu is available in the local HMI under:

ServiceValues

Secondary

2. **Choose 'Secondary' menu and then press the 'E' button.**

The display will present the first set of service values.

3. **Press any button on the local HMI to present the second set of service values.**

-
4. Press any button on the local HMI to return to the 'Secondary' menu.

2.2

Service values menu

The following values are presented when the service value menu is viewed:

Service value	Provides information about
IL1	The actual phase-1 current
IL2	The actual phase-2 current
IL3	The actual phase-3 current
I_N	The actual neutral current
Freq	The actual frequency

3 Using the indications menu

3.1 Reading disturbance information

This section described how to read recorded disturbances during commissioning and maintenance of the relay.

The indications menu is used for presenting information when:

- No disturbance has occurred.
- Disturbance has occurred.

3.1.1 No disturbance has occurred

The user can use the 'Indications' menu to read function status and active setting group even if no disturbance has occurred.

Procedure

1. Browse to the 'Indications' menu from the main menu.

The display will present the status of the overcurrent functions and active setting group.

2. Press any button on the local HMI.

The display presents the remaining status of the overcurrent functions and active setting group.

3. Press any button on the local HMI to present the status of the earth-fault protections.

The status of the earth-fault protections and active setting group is presented.

4. Press any button on the local HMI to return to the main menu.

3.1.2 Disturbance has occurred

The user can use the 'Indications' menu to read function status, setting groups and recorded primary trip values if a disturbance has occurred.

Procedure

1. Browse to the 'Indications' menu from the main menu.

The display will present the status of the overcurrent functions and active setting group

2. Press any button on the local HMI.

The display presents the remaining status of the overcurrent functions and active setting group.

3. Press any button on the local HMI to display the status of the earth-fault protections.

The status of the earth-fault protections and active setting group is presented.

4. Press any button on the local HMI to present the recorded primary trip values.**5. Press any button on the local HMI and the display will present the clearing dialog box.**

Here the recorded disturbances can be cleared or not.

6. Press and hold down the 'C' button for more than two seconds to clear the disturbances or press any button shortly to not clear the disturbances.

If the user choose to clear the disturbances the saved values and LED's will be cleared and the display returns to the main menu.

3.2**Indications menu**

The following indications are presented when the indications menu is entered. Stored primary trip values are always from the last disturbance and will also be presented through this menu.

Indication	Start	Trip	Function description
I>	<input type="checkbox"/> 1/2	<input type="checkbox"/> 1/2	Status and active group for overcurrent, low set stage.
	L123		Phase indication which caused the start on I>
I>>	<input type="checkbox"/> 1/2	<input type="checkbox"/> 1/2	Status and active group for overcurrent, medium set stage.
	L123		Phase indication which caused the start on I>>
I>>>	<input type="checkbox"/> 1/2	<input type="checkbox"/> 1/2	Status and active group for overcurrent, high set stage.
	L123		Phase indication which caused the start on I>>>
I _N >	<input type="checkbox"/> 1/2	<input type="checkbox"/> 1/2	Status and active group for earth-fault, low set stage.
I _N >>	<input type="checkbox"/> 1/2	<input type="checkbox"/> 1/2	Status and active group for earth-fault, medium set stage.
I _N >>>	<input type="checkbox"/> 1/2	<input type="checkbox"/> 1/2	Status and active group for earth-fault, high set stage.

Number 1 or 2 (start and trip) above indicates which setting group that was active during the disturbance. All start functions are connected to the yellow LED and all trip functions are connected to the red LED. The appearance of the boxes in the local HMI describes the status of the function.

Filled (black)	Latest recorded event.
Grayed	Previous recorded event.
Blank	No recorded event (since last clearing).

Recorded trip values	Provides information about
IL1	The recorded phase-1 current
IL2	The recorded phase-2 current
IL3	The recorded phase-3 current
I_N	The recorded neutral current

Chapter 6 Maintenance

About this chapter

This chapter contains instructions on how the preventive and corrective maintenance is performed. A check-list is provided to facilitate troubleshooting the protection.

1

Overview

Before any of these instructions could be carried out the plastic cover which covers the relay has to be removed.

Under normal operating conditions and when the surrounding atmosphere is of non-corrosive nature no special maintenance is required. Preventive maintenance test of the protection assembly is recommended to be performed every four to five years. The tests can be performed more or less detailed. Instructions from utility power network company and other maintenance directives, valid for maintenance of the power system, must be followed.

Corrective maintenance is required if the protection should be suspected to have made an unwanted operation or, missed to clear a fault situation. In a case of an unwanted or missed fault clearing operation, the check list may help the user to recognize the wrong behavior of the protection assembly. If the check list below does not help, please contact the local ABB office for further technical support.

The measuring relay is provided with self-supervision and require less maintenance than earlier designed relays. The internal self-supervision function with error alarm output supervises:

- Software execution flow by the internal watchdog.
- ROM cell's by the checksum program.
- RAM cell's by RAM cell program.



Warning!

Never plug or withdraw a relay from the terminal base without blocking the output circuits or interrupting the auxiliary DC supply. Otherwise there is a risk of unwanted operations.



Note!

If the LED's are flashing or the green 'In service' LED is dark, an internal fault has occurred. Read the self supervision section in the technical reference manual for further information.

2 Preventive maintenance

2.1 Checking the disturbance information

The indications menu should be checked to identify if any disturbance has occurred. If any fault occurs frequently, some actions may be taken.

2.2 Performing a start-up check

Switch-off and on the auxiliary DC supply to the protection. During the start-up sequence the relay verifies the ROM and RAM cell's. When the green LED lights-up all internal checks are completed and the relay is in normal service again.

2.3 Checking the service values

Verify the presented service values in the local HMI and compare them with the known system values. If they are as expected, the external circuits and the internal measuring in the relay work properly. By using this information the user also is informed about the condition of the measuring transformers.

2.4 Testing the binary inputs

Verify the operation of the binary inputs. In the 'Test' menu the user can overview the status when the input is energized. See chapter "Commissioning" in this manual.

2.5 Testing the binary outputs

Verify the operation of the binary output relays. In the 'Test' menu the user can change the state of the selected output. See chapter "Commissioning" in this manual.

2.6 Dressing burned contacts on the auxiliary tripping relays

In exceptional cases, burned contacts on the auxiliary output relays can be dressed with a diamond file.

2.7 Performing additional tests

Additional tests can be selected from the secondary injection tests. See chapter "commissioning" in this manual.

3 Corrective maintenance

This section contains instructions on how the user can investigate a missed fault clearance or an unwanted operation of the protection assembly.

3.1 Check the green “in service” LED on RXTUG 22H

If the “in service” LED is dark, the self supervision in the DC/DC-converter has recognized an internal fault.

Procedure

1. **Check the connection and polarity of the auxiliary input cables.**
2. **Disconnect the output load from the DC/DC-converter.**
3. **Measure both the input (24-250V DC) and output (+/-24V DC) voltages from the DC/DC-converter.**

3.2 Check the green “in service” LED on the measuring relay

If the “in service” LED is dark or any of the other LED’s are flashing the self supervision in the relay has recognize an internal fault. In the technical reference manual further information about the self supervision function is stated.

Procedure

1. **Check the internal connections between the DC/DC-converter and the measuring relay (+/-24V DC).**

3.3 Check the indications

3.3.1 If the expected protection function has not operated correctly

Procedure

1. **Check the service values in the local HMI.**

If the service values are not of the right magnitude check that all screws in the COMBIFLEX[®] relay socket are tightly fastened and also check the internal and external cable connections to the transformers.

2. **Test the binary inputs.**

Check the connection and polarity of the involved binary inputs. Energize it and overview it by the ‘Test’ menu.

3. Check the configuration

Check that all binary inputs and outputs are correctly configured in the relay according to the relay system plan.

4. Check the settings

Check that all protection settings are correctly implemented in the relay according to the relay system plan.

5. Check the setting calculations

Verify the calculated setting values for the relay according to the network conditions.

3.3.2**If the expected protection function has operated correctly****Procedure****1. Test the binary outputs.**

Check the internal connections between the binary output relay and the auxiliary output tripping relay. Check also the external connections from the tripping relay to the circuit-breaker coil.

Chapter 7 Protection assemblies and diagrams

About this chapter

This chapter contains a general description of the protection assemblies. The chapter also contains different terminal and circuit diagrams for the protection assembly.

1 Compact current protection assembly RAHL

The protection assemblies are of protective class I equipment in which protection against electric shock does not rely on basic insulation only, but which includes additional safety precautions in such a way that accessible conductive parts are connected to protective earth. The protections are based on the compact current relay RXHL. Test device RTXP 8, RTXP 18 and DC/DC-converter RXTUG 22H can also be included for specific application requirements. Test device, RTXP 8 and RTXP 18 are tools for relay testing. DC/DC-converter RXTUG 22H can be used either separately for a single protection or to feed other protections of the same relay family. With RXTUG 22H all requirements concerning emission and immunity disturbances with this protection assembly will be met.

The measuring relay has 5 binary outputs and 2 binary inputs. Protections are normally available with output logic with heavy duty contacts, relay RXME 18 with indicating flag, and can upon request be completed with an output logic of free choice. Output relays are connected to separate auxiliary voltage. The interface voltage for enable or block impulses can be connected to either 48-60 V DC or 110-220 V DC by connecting the voltage circuit to separate terminals. At delivery all relays are connected for 110-220 V DC.

All the protections in the COMBIFLEX[®] modular system are mounted on apparatus bars. The connections to the protections are done by COMBIFLEX[®] socket equipped leads. All internal connections are made and the protection assembly is tested before delivery from factory. The type of modules and their physical position and the modular size of the protection are shown in the diagrams of the respective protection. Figure 4 shows an example of a protection assembly.

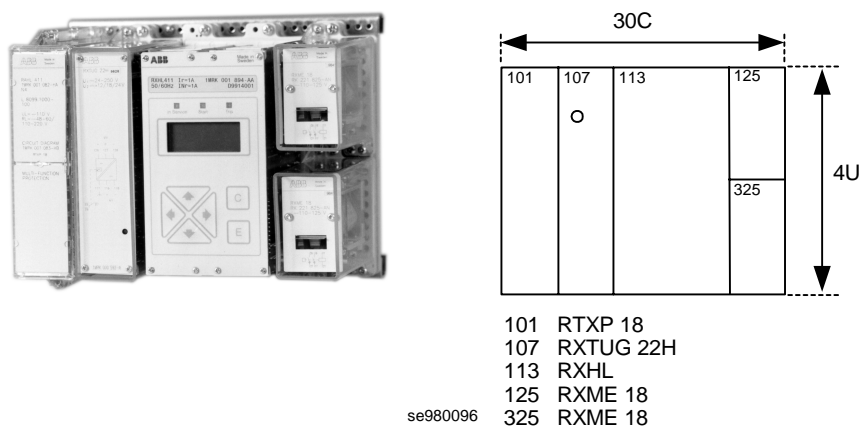
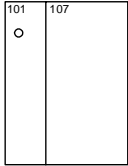
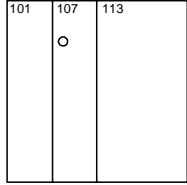
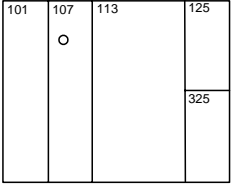

Figure 4: Protection assembly example

The height and width of the protection assembly are given in the circuit diagram with height (U) and width (C) modules, where $U = 44.45$ mm and $C = 7$ mm. The depth of the protection assembly, including space for the connection wires, is approximately 200 mm.

2 Protection assemblies

The table below shows the different variants of the compact current relay RXHL 401 in protection assemblies type RAHL 401.

RAHL 401 protection assembly variants	Ordering No.	Circuit diagram	Terminal diagram	Available diagrams
 <p>101 RXTUG 22H 107 RXHL</p>	1MRK 001 082-AB	1MRK 001 083-AB	1MRK 001 083-ABA	On request
 <p>101 RTXP 18 107 RXTUG 22H 113 RXHL</p>	1MRK 001 082-BB	1MRK 001 083-BB	1MRK 001 083-BBA	On request
 <p>101 RTXP 18 107 RXTUG 22H 113 RXHL 125 RXME 18 325 RXME 18</p>	1MRK 001 082-CB	1MRK 001 083-CB	1MRK 001 083-CBA ^{a)} ^{b)}	

RAHL 401 protection assembly variants	Ordering No.	Circuit diagram	Terminal diagram	Available diagrams
---------------------------------------	--------------	-----------------	------------------	--------------------

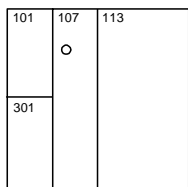

101 RTXP 8
107 RXTUG 22H
113 RXHL
301 RXME 18

1MRK 001 082-DB	1MRK 001 083-DB	1MRK 001 083-DBA	On request
1MRK 001 082-EB ^{c)}	1MRK 001 083-EB ^{c)}	1MRK 001 083-EBA ^{c)}	^{b)}

- a) Terminal diagrams available in technical overview brochure for RXHL 401 and RAHL 401
- b) Terminal and circuit diagrams available in installation and commissioning manual for RXHL 401 and RAHL 401
- c) Selection of phase and neutral current must be the same, $I_r = IN_r = 1\text{ A}$ or $I_r = IN_r = 5\text{ A}$

2.1 Mounting alternatives

The protection assemblies described in the table above can be supplied in RHGX or RHGS cases. RXHL 401 compact current relay can also be supplied in the following mounting alternatives.

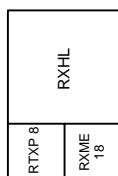

Mounting of RXHL 401 in RHGS 6.



Mounting of RXHL 401 in RHGS 12.

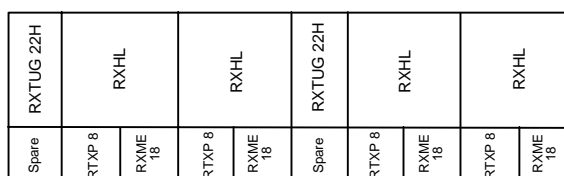

Mounting of RXHL 401 in RHGS 30 with dual power supplies RXTUG 22H, individual test switches and optional tripping relays.

3 Terminal and circuit diagrams

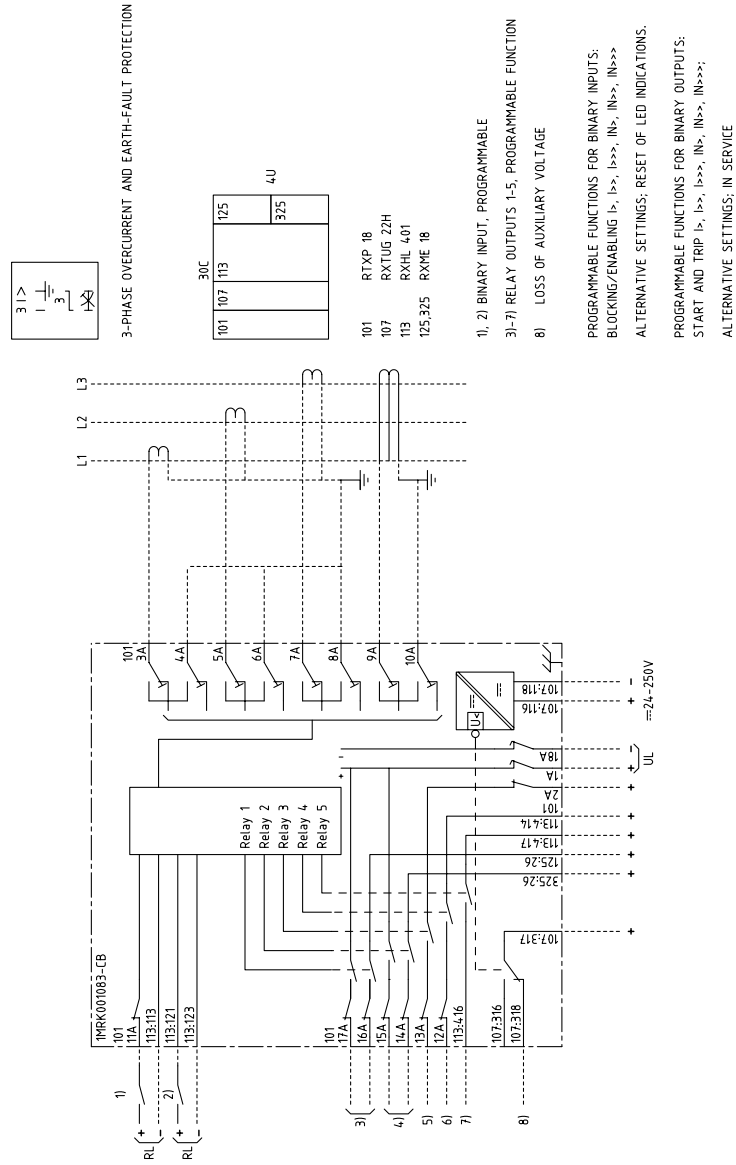

Figure 5: Terminal diagram IMRK 001 083-CBA

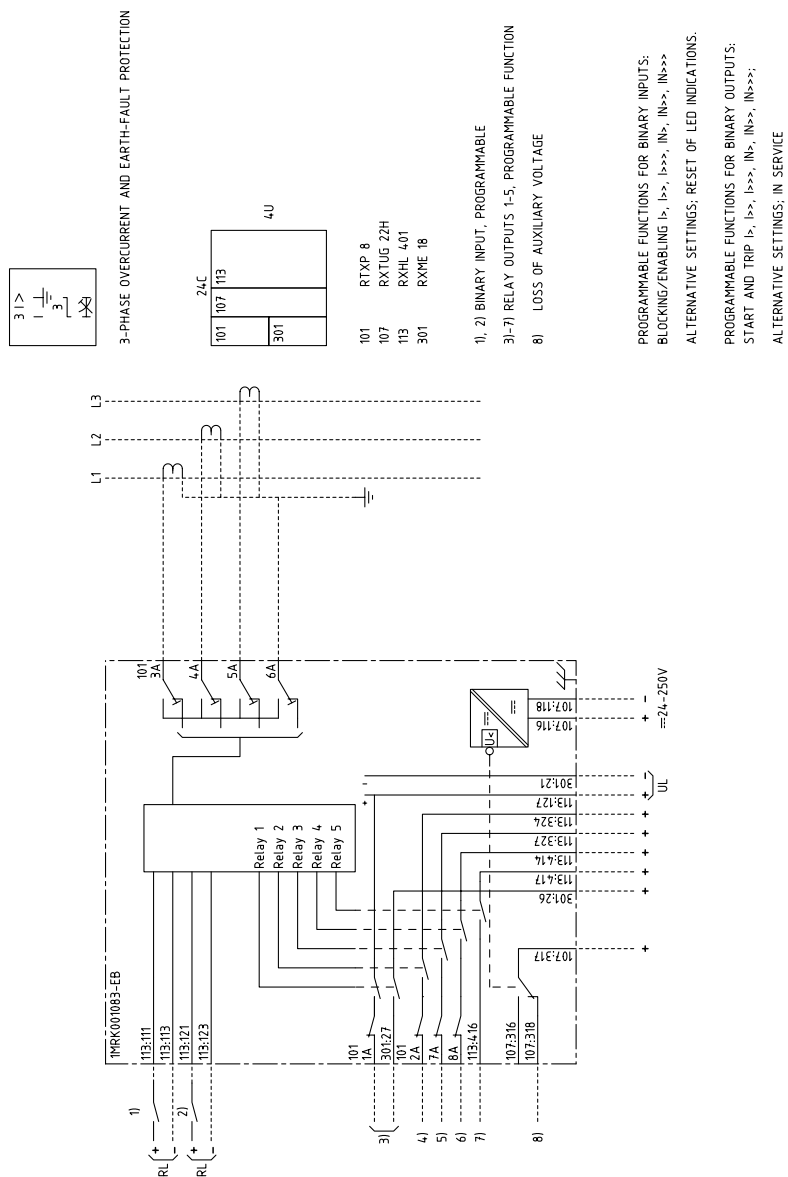

Figure 6: Terminal diagram 1MRK 001 083-EBA

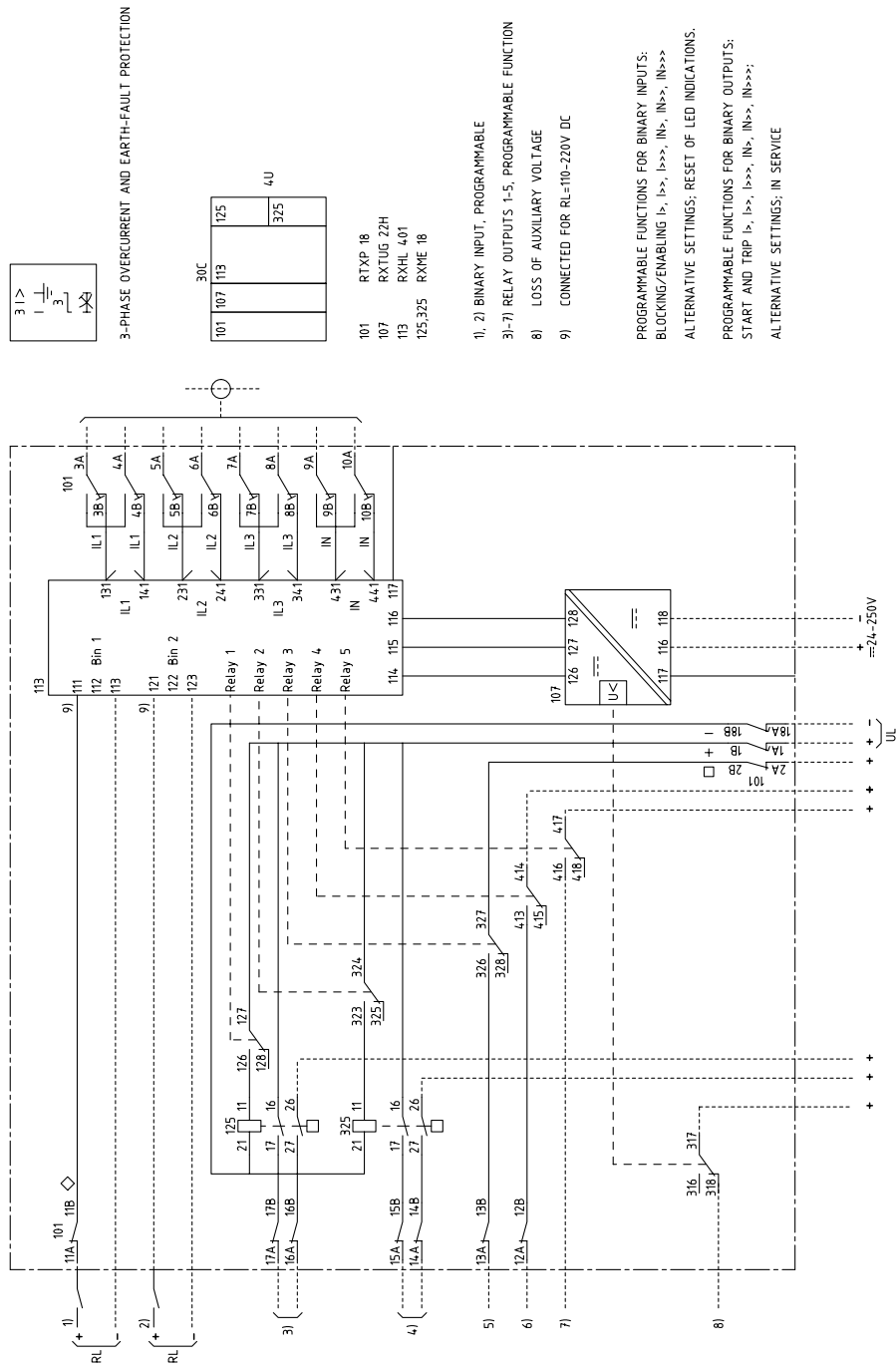

Figure 7: Circuit diagram 1MRK 001 083-CB

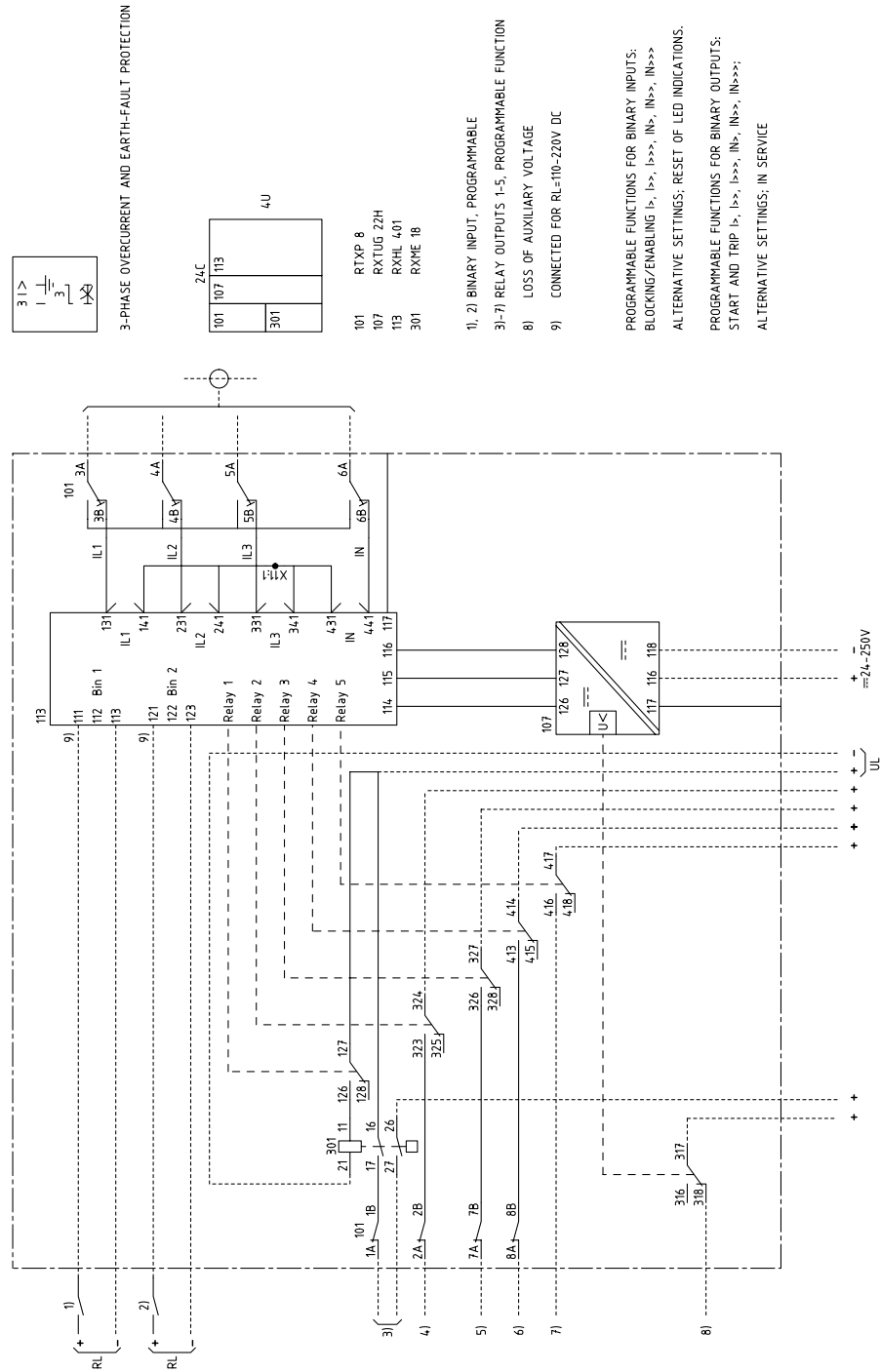

Figure 8: Circuit diagram 1MRK 001 083-EB

Chapter 8 Test records

About this chapter

This chapter contains test records which could be used during commissioning of the protection. There is one test record for each protection function available in the relay.

1

Compact current relay RXHL 401**Table 18: General information**

Customer:

Station:

Tested by: Date:

Approved by: Date:

Table 19: General station information

Protected object :

Relay position :

CT-ratio, phase :

CT-ratio, neutral :

Table 20: General relay data

Order number :

Rated phase current I_r :

Rated neutral current I_{Nr} :

Version number VerNo :

Serial number SerNo :

Table 21: General relay settings

Rated frequency F_r :

Main CT-ratio, phases Prim :

Sec :

Main CT-ratio, neutral Prim :

Sec :

Active setting group Grp :

2**Service value****Table 22: Service value check**

	Actual injected value:	Primary value:	Secondary value:
Phase IL1	:	:	:
Phase IL2	:	:	:
Phase IL3	:	:	:
Neutral I_N	:	:	:

3 Overcurrent protection

3.1 Protection settings

		Setting group 1	Setting group 2
Low set stage, I>	Active	:	:
	Operate level	:	:
	Characteristic	:	:
	Constant k value	:	:
	Time delay	:	:
	Reset time delay	:	:
Medium set stage, I>>	Active	:	:
	Operate level	:	:
	Time delay	:	:
High set stage, I>>>	Active	:	:
	Operate level	:	:
	Time delay	:	:

3.2 Protection configurations

	Block/Enable	Binary input
Block/Enable I>	:	:
Block/Enable I>>	:	:
Block/Enable I>>>	:	:
Binary output		
I>start	:	
I>trip	:	
I>>start	:	

I>>trip :
 I>>>start :
 I>>>trip :

3.3 Operate and reset values

Table 23: Low set stage, I>

Set value	Phase IL1		Phase IL2		Phase IL3	
	Pick-up	Drop-out	Pick-up	Drop-out	Pick-up	Drop-out
Group 1, I>	:	:	:	:	:	:
Group 2, I>	:	:	:	:	:	:

Table 24: Medium set stage, I>>

Set value	Phase IL1		Phase IL2		Phase IL3	
	Pick-up	Drop-out	Pick-up	Drop-out	Pick-up	Drop-out
Group 1, I>>	:	:	:	:	:	:
Group 2, I>>	:	:	:	:	:	:

Table 25: High set stage, I>>>

Set value	Phase IL1		Phase IL2		Phase IL3	
	Pick-up	Drop-out	Pick-up	Drop-out	Pick-up	Drop-out
Group 1, I>>>	:	:	:	:	:	:
Group 2, I>>>	:	:	:	:	:	:

3.4 Time measurements

Table 26: Inverse time delay, low set stage, I>

Setting	Injected current	Injected current	Phase IL1	Phase IL2	Phase IL3
Group 1	1.3 x set value	:	:	:	:

Setting	Injected current	Injected current	Phase IL1	Phase IL2	Phase IL3
Group 2	2.0 x set value	:	:	:	:
	1.3 x set value	:	:	:	:
	2.0 x set value	:	:	:	:

Table 27: Definite time delay, injected current 1.3 x set operate value

Setting	Function	Phase IL1	Phase IL2	Phase IL3
Group 1	Low set stage, I>	:	:	:
	Medium set stage, I>>	:	:	:
	High set stage, I>>>	:	:	:
Group 2	Low set stage, I>	:	:	:
	Medium set stage, I>>	:	:	:
	High set stage, I>>>	:	:	:

3.5

Functional check

Testhandle checked in all positions	:
Trip circuit checked	:
Alarm circuits checked	:

4 Earth-fault protection

4.1 Protection settings

		Setting group 1	Setting group 2
Low set stage, $I_N>$	Active	:	:
	Operate level	:	:
	Characteristic	:	:
	Constant k value	:	:
	Time delay	:	:
	Reset time delay	:	:
	Medium set stage, $I_N>>$	Active	:
	Operate level	:	:
	Time delay	:	:
	High set stage, $I_N>>>$	Active	:
	Operate level	:	:
	Time delay	:	:

4.2 Protection configurations

	Block/Enable	Binary input
Block/Enable $I_N>$:	:
Block/Enable $I_N>>$:	:
Block/Enable $I_N>>>$:	:
Binary output		
$I_N>$ start	:	
$I_N>$ trip	:	
$I_N>>$ start	:	

$I_N >> \text{trip}$:
 $I_N >>> \text{start}$:
 $I_N >>> \text{trip}$:

4.3 Operate and reset values

Setting	Set value	Neutral I_N	
		Pick-up	Drop-out
Group 1	Low set stage $I_N >$:	:
	Medium set stage $I_N >>$:	:
	High set stage $I_N >>>$:	:
Group 2	Low set stage $I_N >$:	:
	Medium set stage $I_N >>$:	:
	High set stage $I_N >>>$:	:

4.4 Time measurements

Table 28: Inverse time delay, low set stage, $I_N >$

Setting	Function	Injected current	Neutral I_N
Goup 1	1.3 x set operate value	:	:
	2.0 x set operate value	:	:
Group 2	1.3 x set operate value	:	:
	2.0 x set operate value	:	:

Table 29: Definite time delay, injected current 1.3 x set operate value

Setting	Function	Injected current	Neutral I_N
Group 1	Low set stage, $I_N >$:	:
	Medium set stage, $I_N >>$:	:
	High set stage, $I_N >>>$:	:

Setting	Function	Injected current	Neutral I_N
Group 2	Low set stage, $I_N >$:	:
	Medium set stage, $I_N >>$:	:
	High set stage, $I_N >>>$:	:

4.5**Functional check**

Testhandle checked in all positions	:
Trip circuit checked	:
Alarm circuit checked	:

