



RAIDK, RAIDG, RAPDK and RACIK Phase overcurrent and earth-fault protection assemblies based on single phase measuring elements

User's Guide
1MRK 509 031-UEN

Version 1
April 1999



General

Most faults in power systems can be detected by applying overcurrent relays set above normal load current.

Earth-fault relays can be set below the phase load current and offer effective protection for the majority of single-phase-to-earth and two-phase-to-earth faults. Non-directional overcurrent relays are primarily used in radially fed systems, whereas networks having multiple infeeds often use directional overcurrent relays for improvements in selectivity. Inverse or independent time-delayed protection relays with high set instantaneous or short delayed elements stages are used.

The COMBIFLEX[®] range of overcurrent relays is designed to meet the requirements for overcurrent and earth-fault protections in most power system applications, including those that require a special frequency response. For the general overcurrent application a very wide setting ranges are available with these relays, obviating the need to specify different versions depending on the protective relay location of the protection or the voltage level of the power system. The single-phase relay designs coordinate well with other existing single-phase relay applications in the networks.

All protection relays are mounted in the COMBIFLEX[®] modularised system and are available with or without test switch, DC/DC converter and heavy duty tripping relays with hand reset flag.

RAIDK can be used as general purpose one-, two- or three-phase overcurrent protection and/or earth-fault protection.

RAIDG can be used as sensitive and selective earth-fault protection for use in solidly earthed HV networks, including e.g. 400 kV EHV systems.

RAPDK can be used as one-, two- or three-phase directional overcurrent protection and/or directional earth-fault protection.

RACIK two- or three-phase overcurrent protection and directional or non-directional earth-fault protection for use in unearthed, high impedance or solidly earthed networks

RXIDK 2H

- time-overcurrent relay with two current stages; 0,075-3,25 and 0,1-40 times rated current
- three current variants with the rated currents 0,2 A, 1 A and 5 A respectively
- five inverse time characteristics and definite time delay 50 ms - 8,1 s for the low set stage
- up to 1 s delay of the high set stage for fuse selectivity
- variants for measuring of 16 2/3 Hz flat, 50-60 Hz flat (standard), 50-60 Hz sharp, 150-180 Hz sharp and 40-2000 Hz flat
- binary input to enable or block the operation or to increase the operate value of the low set stage

RXIDG 21H

- time-overcurrent relay with unique logarithmic inverse time characteristic
- one current stage with setting range 15 mA - 2,6 A
- binary input to enable or block the operation

RXPDK 21H

- directional time-overcurrent relay with voltage polarisation 5 - 200 V
- voltage phase memory for correct directional operation down to zero voltage
- two current stages; directional 0,075-3,25 and non-directional 0,1-40 times rated current 1 A or 5 A
- five inverse time characteristics and definite time delay 50 ms - 8,1 s for the directional stage
- the characteristic angle settable between -120° and $+120^\circ$ / -12° and $+12^\circ$
- two binary inputs to reset indications and to block the operation of directional delayed stage
- alternative version where it is possible to change the function to be non-directional

RXPDK 22H

- uni- or bidirectional time-overcurrent relay with voltage polarisation and overvoltage enabling
- or non-directional time-overcurrent relay with undervoltage enabling
- two current variants with setting ranges 3,7 - 163 mA and 15 - 650 mA respectively
- the characteristic angle manual or remote settable to 0° or -90°
- separate built-in over or undervoltage protection function, can e.g. be used as neutral point voltage
- two binary inputs to reset indications and to change the characteristic angle

RXPDK 23H

- directional time-overcurrent relay with sensitive voltage polarisation 0,5 V
- two current stages; directional 0,075-3,25 and non-directional 0,1-40 times rated current 1 A or 5 A
- operation if the phase angle is within the range 0° to 140° and the current exceeds the setting value
- two binary inputs to reset indications and to block or enable the overcurrent functions

List of contents

	General	1
	List of contents.....	3
1	Application	5
1.1	Overcurrent protection	6
1.1.1	Three-phase or two-phase circuit protection	6
1.1.2	Time characteristics	6
1.1.3	Selectivity	8
1.1.4	Non-directional overcurrent protection	9
1.1.5	Directional overcurrent protection	11
1.1.6	Back-up protection	12
1.1.7	Example of selectivity plan	13
1.2	Earth-fault protection	17
1.2.1	Earth-fault protection in unearthed or high-impedance earthed system	18
1.2.2	Earth-fault protection in low-impedance earthed system	20
1.2.3	Earth-fault protection in solidly earthed system	20
1.2.3.1	Second harmonic restraint operation with RAISB	22
1.2.4	Connection of earth-fault relay	22
1.3	Demands on the current transformers	22
1.3.1	Overcurrent protection	23
1.3.2	Limiting secondary e.m.f, Eal - Calculation example	24
1.3.3	Earth-fault protection	25
1.4	Other applications.....	26
1.5	Frequency ranges.....	27
2	Measurement principles.....	28
2.1	The RXIDK 2H and RXIDG 21H relays	28
2.2	The RXPDK 21H, RXPDK 22H and RXPDK 23H relays	30
2.2.1	The RXPDK 21H relay	30
2.2.2	The RXPDK 22H relay	32
2.2.3	The RXPDK 23H relay	33
3	Design	35
3.1	Test switch.....	35
3.2	DC-DC converter	35
3.3	Measuring relays	35
4	Setting and connection	38
5	Technical data.....	48
5.1	Time-overcurrent relay RXIDK 2H	48
5.2	Time overcurrent relay RXIDK 2H, 16 Hz	51
5.3	Time-overcurrent relay RXIDG 21H	53
5.4	Technical data common for RXIDK 2H and RXIDG 21H	54
5.5	Directional time-overcurrent relay RXPDK 21H.....	59
5.6	Directional time-overcurrent relay RXPDK 22H.....	61
5.7	Directional time-overcurrent relay RXPDK 23H.....	64
5.8	Technical data common for RXPDK 21H, RXPDK 22H and RXPDK 23H.....	66
5.9	Inverse time characteristics	68
6	Receiving and Handling and Storage	74
6.1	Receiving and Handling	74

6.2	Storage	74
7	Installation, Testing and Commissioning.....	75
7.1	Installation.....	75
7.2	Testing.....	79
7.2.1	Testing of 50 and 60 Hz protection assemblies with non-directional current relays	79
7.2.2	Testing of 50 and 60 Hz directional current relays with single-phase test set.....	81
7.3	Commissioning	84
7.3.1	Directional test of the earth-fault relay	85
8	Maintenance	87
9	Circuit and terminal diagrams	88

1 Application

Non-directional and directional time-overcurrent relays are used in power systems for many different applications. They are mainly used as short-circuit and earth-fault protection on all types of object in the network. The availability of six different inverse time characteristics and the independent time-delayed stage make the relays suitable for protection of a variety of objects including applications requiring co-ordination with existing time-overcurrent relays.

By combining the time-overcurrent relays RXIDK 2H and RXIDG 21H and the directional time-overcurrent relays RXPDK 21H, RXPDK 22H and RXPDK 23H it is possible to obtain protection assemblies for a very wide range of applications e.g. as main and backup protection for distribution and industrial systems, transformers, capacitor banks, electric boilers, motors and small generators, or as backup protection for transmission lines, transformers and generators. The low transient overreach and short recovery time ensures suitability for most applications.

RAIDK contains measuring relay RXIDK 2H.

RAIDG contains measuring relay RXIDG 21H.

RAPDK contains measuring relay RXPDK 21H or RXPDK 22H or RXPDK 23H or RXPDK 21H and RXPDK 22H or RXPDK 21H and RXPDK 23H.

RACIK contains measuring relays RXIDK 2H and RXIDG 21H, or RXIDK 2H and RXPDK 22H or RXIDK 2H and RXPDK 23H.

Non-directional overcurrent relays are primarily used in radial systems, whereas networks having multiple infeed often use directional overcurrent relays for improvements in selectivity.

Protection systems have to fulfil different utility requirements. Often they also have to fulfil requirements specified in national safety regulations. In general the requirements can be summarised as follows:

- The protection system shall have a high degree of dependability. This means that the risk of missing fault clearance shall be low. Back-up protection is necessary to achieve this.
- The protection system shall have a high degree of security. This means that the risk of unwanted relay function shall be low.
- The fault clearing time shall be minimized in order to limit the damages to equipment, to assure angle stability and to minimize the risk for people from getting injuries.
- The protection system shall have sufficient sensibility so that high resistive faults can be detected and cleared.
- The fault clearing shall be selective to minimize the outage and make it possible to continue the operation of the healthy parts of the power system.

1.1 Overcurrent protection

Two-phase or three-phase time-overcurrent relay is used as phase short-circuit protection in radial networks for over-head lines, cable lines and transformers. In networks with parallel feeders or networks with infeed from several points directional time-overcurrent relays may be used.

1.1.1 Three-phase or two-phase circuit protection

In power systems with high impedance earthing, large fault currents only occur in case of phase-to-phase and three phase short circuits. In case of such a fault there will be high current in at least two of the three phases during the short circuit moment. In solidly earthed system high current can be a consequence also at single phase-to-earth short circuits. Below is discussed the choice of three-phase or two-phase circuit protection in systems with high impedance earthing.

In a three-phase protective relay, both phase currents are always measured when a two-phase fault occurs. The relay operates, therefore, even if one of the measuring circuits should be faulty. A three-phase protection is therefore more dependable than a two-phase protection. Compared to a summing type of protection, that has a common measuring circuit, considerably greater dependability is achieved.

As there always will be fault currents in at least one of the phases during short-circuit, it often is quite adequate to use two-phase protection for the feeders. It is absolutely necessary that the overcurrent relays are located in the same phases all over the network.

In networks with low short-circuit power, three-phase relays may, in some cases, be necessary. In the event of a two-phase short circuit on one side of a D/Y-connected transformer, full short-circuit current will only flow in one of the phases on the other side of the transformer. Approximately half the short-circuit current will flow in the other phases. If a protection had to detect a fault through the transformer and a two-phase short-circuit protection is used, the operation can be unreliable in this case.

There is always a risk of cross-country faults. This means that there will be a phase to earth fault in one phase for one feeder and in another phase for another feeder. If two phase over-current relays are used for the feeders in the system, there is a risk that the faulted phase on one of the feeders will be the non-protected phase. This can result in an unwanted delay of the fault clearance. If a three-phase over-current protection is used this risk will be eliminated.

1.1.2 Time characteristics

To achieve selective fault clearing the different protections and stages have to have different time delays. Several different time characteristics are available. They are described below and some general guide-lines are given. However, as a general rule, different time characteristics should not be used in one and the same system if not necessary. An appropriate characteristic is therefore chosen on the basis of previous practice.

Definite-time characteristic

The operate time is independent of the fault current magnitude. The calculation of settings is easier than for inverse characteristic but the time delay often will be unnecessary long, especially when there are several overcurrent relays in series in the system. The short-circuit power should not vary too much when using the definite-time characteristic.

Inverse time characteristics

The operate time is dependent of the fault current magnitude. For the coordination between the relays the inverse time characteristic is beneficial.

There are four standard inverse time curves: normal, very, extremely and long-time inverse. The relationship between current and time on the standard curves complies with the standard IEC 60255-3 and can generally be expressed as:

$$t = \frac{k \cdot \beta}{\left(\frac{I}{I>}\right)^\alpha - 1}$$

where:

t = operating time in seconds

k = settable inverse time factor

I = measured current value

I> = set current value.

α = index characterizing the algebraic function

β = constant characterizing the relay

The characteristic is determined by the values of the constants α and β :

Characteristic	α	β
Normal inverse	0,02	0,14
Very inverse	1,0	13,5
Extremely inverse	2,0	80,0
Long-time inverse	1,0	120,0

According to the standard IEC 60255-3 the normal current range is defined as 2 - 20 times the setting. Additionally, the relay must start at the latest when the current exceeds a value of 1,3 times the set start value, when the time/current characteristic is normal inverse, very inverse or extremely inverse. When the characteristic is long-time inverse, the normal range in accordance with the standard is 2 - 7 times the setting and the relay is to start when the current exceeds 1,1 times the setting.

The characteristic of the RXIDK 2H, RXPDK 21H and RXPDK 23H satisfy the defined function in the standard at least down to 1,3 times the setting.

Normal inverse characteristic

Normal inverse characteristic is suitable in systems with a large variation in short-circuit power fault currents for different fault locations. The characteristic is shown in Fig 35 in section 5.

Very inverse characteristic

The operate time is more dependent of the fault current magnitude. This characteristic is suitable if there is a substantial reduction of fault current as the distance from the power source increases. Very inverse gives a steeper curve than normal inverse and gives advantages in achieving selectivity between incoming and outgoing bays with small difference in fault current. The characteristic is shown in Fig 36 in section 5.

Extremely inverse characteristic

The operate time is very dependent of the fault current magnitude. This characteristic is intended for co-ordinating with fuses on distribution or industrial circuits. The fuses are used in situations requiring a high degree of overload capacity utilisation and where cold-load pick-up or energizing transient currents can be a problem. The characteristic is shown in Fig 37 in section 5.

Long-time inverse characteristic

This characteristic has the same current dependence as the Very inverse characteristic. It is used when longer time delays are desired. The characteristic is shown in Fig 38 in section 5.

RI inverse characteristic

This characteristic is provided for applications requiring co-ordination with the original ASEA type RI electromechanical inverse time relays. The characteristic is shown in Fig 39 in section 5.

1.1.3 Selectivity

In order to obtain selective tripping of the series connected breakers in the network, the time delay setting must increase for each step towards the infeed point. This means that the tripping times will be longer the higher up in the network the overcurrent relay is placed, but at the same time the short-circuit currents are increasing. It is therefore important that the time intervals between the different selectivity stages are the shortest possible. The minimum time interval between relays, to be selective to each other, is dependent of the following factors: the difference in pick up time of the relays, the circuit breaker opening time and the relay resetting time. If definite-time characteristic is used, 0.3 s is usually recommended as a minimum time interval when the same types of relays are used.

The time interval has to be longer when using inverse characteristic, due to anticipated larger spread in the time function between different relays in the system, compared to the definite-time. To be on the safe side a time interval of 0.4 s is sufficient for normal inverse, very inverse and extremely inverse characteristics at a current corresponding to the highest through-fault current or possibly the current that corresponds to the setting of the instantaneous operation if this function is used.

1.1.4 Non-directional overcurrent protection

Due to the microprocessor timing accuracy, these new relays can generally be used with a tighter coordination margin than required for earlier static and electromechanical relays.

RXIDK 2H has a start-, a low set stage- ($I>$) and a high set stage- ($I>>$) function. The relay also has a fully isolated binary input. With dip switches on the front it can be programmed to enable or block the relay. As an alternative the binary input can raise the operate value of the low set stage with 40%. This function is called "cold load" pick up prevention and facilitates restoration of distribution systems after an outage.

Start function

The start function of RXIDK 2H operates instantaneously when the current exceeds the set value on $I>$.

In radial supplied networks, this function can be used in a blockable busbar protection scheme. In other cases, it can be used for starting printers, autoreclosing or signalling.

The current setting is determined by the loading capacity of the object and by the minimum fault current within the protected zone. This zone can either be the main protected object only, or it can also include objects more remote in the radial network. In the latter case, backup protection is obtained if the primary protection or the circuit-breaker, of the more remote object, should fail to operate.

Low set stage function

The low set stage function is a delayed function and operates for currents down to the start function, as described above. The time characteristic is selected according to the recommendation given above. The delay of the trip signal is set with consideration to the demand on selectivity and the thermal characteristics of the installation.

High set stage function

The high set stage can be set instantaneous or definitive-time delayed. The function can also be blocked whenever necessary.

The instantaneous function is normally set to act for nearby faults and large fault currents. The reach is dependent on the variations in the short-circuit power and on the type of fault. Constant short-circuit power increases the possibility of using the instantaneous function also in networks which have moderate impedances.

In the case of a transformer, a fault on the low voltage side will never give rise to a fault current that has a magnitude greater than a given value. An instantaneous step, that has a higher operate value, has a well-defined reach towards but never through the transformer.

To prevent the instantaneous high current function from reaching through the transformer, consideration must be taken to the following:

- The relay's transient overreach due to a possible DC component in the fault current
- Variations in the short-circuit impedance of the transformer due to the positions of the tap changer
- The magnitude of switching-current surge
- The influence of the fault current through the transformer as influenced from the switching state of parallel transformers

Normally, the impedance at the centre position of the tap changer is given with a few percents variation in the end positions. The instantaneous function is therefore set to approximately 120% of the maximum fault current. In certain cases, a little higher setting may be necessary. Assume the maximum fault current, at a short circuit at the low voltage side of the transformer, I_{max} . The setting of the high current stage can be chosen as:

$$I_{set} \geq 1.2 \cdot k_t \cdot I_{max}$$

k_t is the transient overreach of the relay.

In the case of protection located far out in a radial system, the instantaneous function is most appropriate. The adjustable independent time delay (0,03-1,0 seconds) enables selectivity towards fuses located farthest out in the system.

In those cases where selectivity with instantaneous function cannot be achieved, it is possible to block the function.

By utilising longitudinal differential protection on strategically selected cables and lines, instantaneous and selective tripping is achieved for these. One or more selective steps can therefore be omitted. Other cables and lines can be protected with normal overcurrent relays since these have shorter tripping times. (See Fig 1) This can be of special interest, for example in large industrial installations in which the short-circuit power has increased successively due to extension of the network or in distribution systems consisting of a mixture of short and long cables and lines.

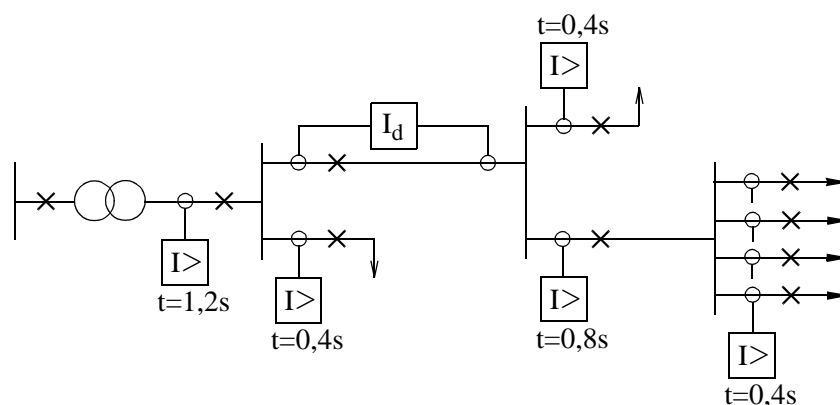

Fig. 1 Example showing how a longitudinal differential protection can reduce the number of selective steps

1.1.5 Directional overcurrent protection

In some applications it is not possible to achieve an acceptable protection using non-directional overcurrent relays. Often the use of distance protection or differential protection can solve the problem. Sometimes directional overcurrent protections will give acceptable solutions. In these applications the directional time-overcurrent relay RXPDK 21H can be used.

For example in the case of parallel lines supplied from several directions, directional overcurrent relays can be used. In radial systems which have two parallel lines, selective tripping can be achieved with four overcurrent relays, two of which are directional as shown in Fig 2

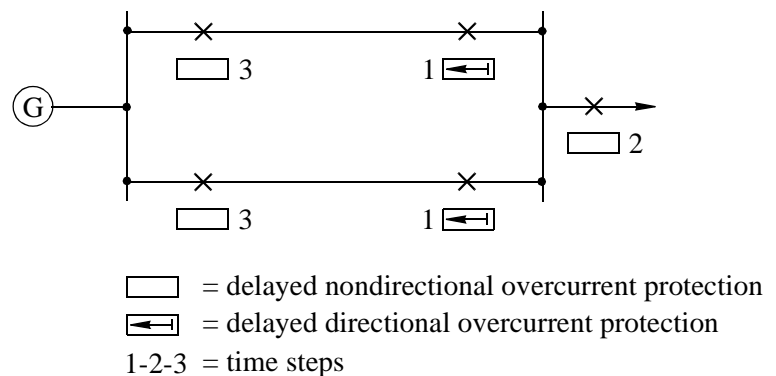

Fig. 2 Radially supplied system with parallel lines

In transmission system directional overcurrent relays can be used for protection systems using communication. This is done mostly for earth fault protection schemes. Permissive overreach, permissive underreach as well as blocking schemes can be used. One binary output of RXPDK 21H or RXPDK 23H is used for initiation of sending of acceleration or blocking signal. The binary output is also used to enable trip when all other criteria for trip are fulfilled.

RXPDK 21H has a directional start-, a directional low set stage- (I_{α}) and a non-directional high set stage- ($I_{>>}$) function. The relay has also two fully isolated binary inputs. One is used for external blocking of the directional low-set delayed stage. The directional low-set start and non-directional high-set stage will be unaffected. The other binary input is used for remote reset of the LED indicators. Alternative version where it is possible to change the function to be non-directional

The start and low-set functions of the relay operate when $I \cdot \cos(\varphi - \alpha)$ exceeds the set value. φ is the angle between reference voltage and fault current. This angle is positive if the current lags the voltage. The characteristic angle α is settable between -120° to $+120^\circ$.

The start function operates instantaneously when the current exceeds the set value and the time characteristics for the low set stage are the same as in RXIDK 2H described above.

The operating time for the high set stage is always instantaneous and does not have a settable time delay.

The relay shall normally be connected with the current circuit to one phase and the voltage circuit between the two other phases when used as overcurrent protection for short-circuit. If the characteristic angle α is set $\alpha = -30^\circ$ the protection then will have maximum sensitivity when the angle between the source phase voltage and the phase current is 60° which is a common phase angle for phase to phase short circuits.

1.1.6 Back-up protection

In meshed systems overcurrent relays can be used as back up protection for phase to phase short circuits and phase to earth short circuits on transmission lines. A very simple way to realise this kind of back up protection scheme is to use a two stage overcurrent relay. The high current stage, with short time delay for operation, is given a current setting to assure selectivity. In practice this means that this stage will normally only cover a small portion of the line. The low current stage, with a longer time delay for operation, is given a current setting so that the whole transmission line is covered. The difficulty with this kind of back up protection is that the settings must be valid for different operation states of the system, with different fault current levels.

A more sophisticated back up protection scheme can be realised as described below. In meshed systems which are supplied from several directions (Fig 3), the current sensed by the relays during a fault will vary considerably. In such cases, inverse time overcurrent protections which all have the same setting can be used as backup protections. This provides good results since the fault current to the faulty line will always be higher than the fault current fed from the faultless lines, and therefore give the shortest tripping time. There can however be some difficulties in case of small substations, e.g. stations with only two connected feeders. With a fault on one of the feeders, the feeders will have the same fault current.

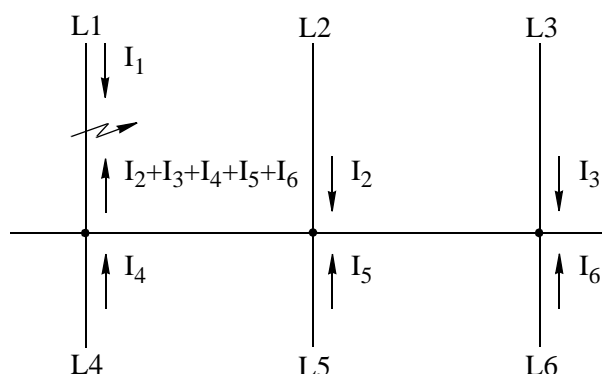

Fig. 3 System with several supply circuits

In radial distribution systems normally the overcurrent protection for the supply transformer shall serve as back-up protection for the feeders. In many stations the combination of high rated power of the transformer and

long feeders makes it impossible to achieve acceptable back-up function to a large extent of the feeders. The problem will be even worse if two transformers operate in parallel.

To fulfil the basic requirement of back-up protection, the feeders that are lacking back-up function, should be equipped with a supplementary overcurrent protection, and breaker failure protection.

1.1.7 Example of selectivity plan

The settings of the overcurrent protections in a radial network are to be calculated. The relays have normal inverse characteristic and are located as shown in Fig 4.

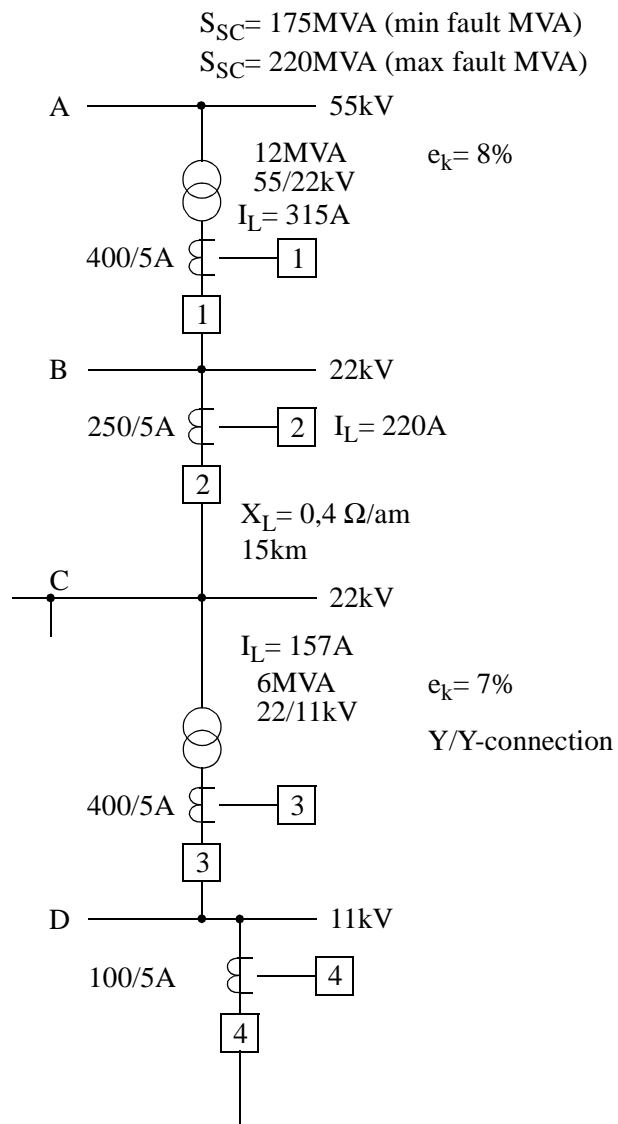

Fig. 4 Radial network

Determine the equivalent impedance network related to the 22 kV level (Fig 5) and calculate the fault currents, on the 22 kV voltage level. In the example all impedances are considered to be pure reactances.

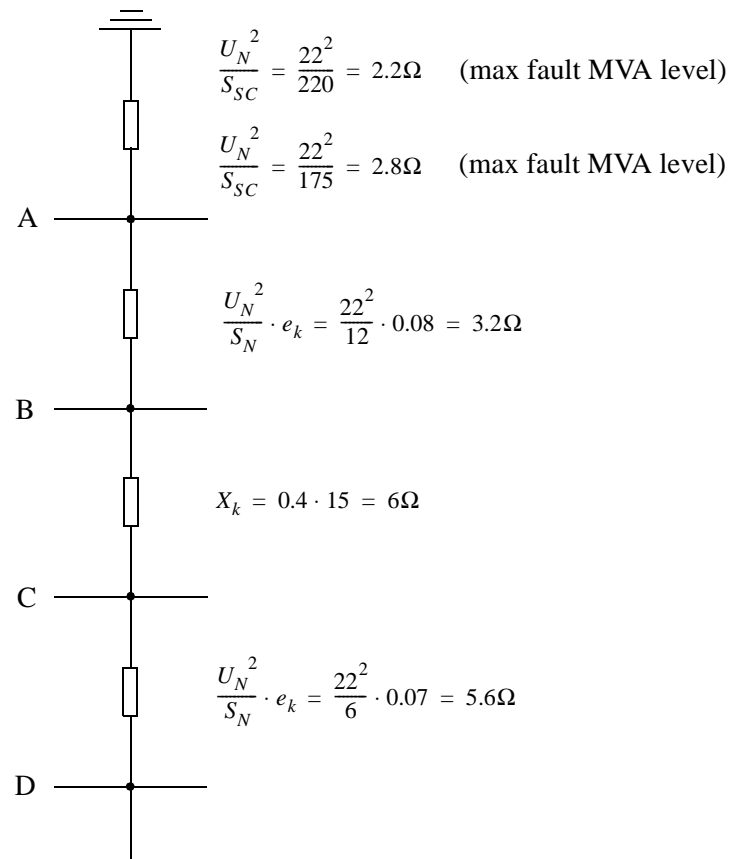

Fig. 5 Equivalent impedance network

The short circuit currents are calculated for different fault points in the system. This is done for both maximum and minimum short circuit capacity.

Three-phase short-circuit current

$$I_k = \frac{22}{\sqrt{3} \cdot X_k}$$

$$I_{kA \text{ max}} = \frac{22}{\sqrt{3} \cdot 2.2}$$

$$I_{kB \text{ max}} = \frac{22}{\sqrt{3} \cdot (2.2 + 3.2)}$$

$$I_{kA \min} = \frac{22}{\sqrt{3} \cdot 2.8}$$

$$I_{kB \min} = \frac{22}{\sqrt{3} \cdot (2.8 + 3.2)}$$

The phase to phase short circuit current can be found by multiplying the three phase short circuit current by a factor $\frac{\sqrt{3}}{2}$.

Max values:	Min values:
$I_{kA} = 5\,770\text{ A}$	$I_{kA} = 4\,540\text{ A}$
$I_{kB} = 2\,350\text{ A}$	$I_{kB} = 2\,120\text{ A}$
$I_{kC} = 1\,110\text{ A}$	$I_{kC} = 1\,060\text{ A}$
$I_{kD} = 750\text{ A}$	$I_{kD} = 720\text{ A}$

Relay 4

The present setting of relay 4 is retained. The primary setting, referred to 22 kV is given in the time curves in Fig 6

Low set stage $I_{>} = 50\text{ A}$

High set stage $I_{>>} = 250\text{ A}$

Inverse time factor $k = 0.10$

Referred to the relay side:

$$I_{>} = 50 \cdot \frac{22}{11} \cdot \frac{5}{100} = 5\text{ A}$$

$$I_{>>} = 250 \cdot \frac{22}{11} \cdot \frac{5}{100} = 25\text{ A}$$

Relay 3

The rated current I_L of the power transformer is 315 A at 11 kV. The overload capacity of the transformer is considered to be 40%. A normal setting for the low set function is calculated:

$$I_{\geq} = \frac{1.4 \cdot I_L}{\eta} = \frac{1.4 \cdot 315}{0.9} = 490\text{ A}$$

η is the resetting ratio of the relay. 500 A seems to be a reasonable choice for current setting of the low set stage. It shall be observed that the protection in this case will be a short-circuit protection and not an overload protection.

Low set stage

$$I_{>} = 500 \cdot \frac{5}{400} = 6.25 \text{ A}$$

Referred to 22 kV the low set stage will be

$$I_{>} = 500 \cdot \frac{11}{22} = 250 \text{ A}$$

The high set stage must be blocked in order to achieve selectivity for faults on outgoing lines from D. To co-ordinate the time delay, the inverse time factor $k = 0.05$ is chosen from the time curve in Fig 6 and 35.

Relay 2

This relay constitutes a back-up protection for faults occurring on busbar D. Determine the minimum two-phase fault current on busbar D:

$$I_{k \min} = 720 \cdot \frac{\sqrt{3}}{2} = 620 \text{ A}$$

The maximum setting of low set stage to assure fault clearance at busbar D:

$$I_{>} = 0.7 \cdot I_{k \min} = 0.7 \cdot 620 = 430 \text{ A}$$

Select the low set stage setting $I_{>} = 300 \text{ A}$ in order to obtain a good margin to the load current for the feeder $I_L = 220 \text{ A}$. The high set stage must be selective with respect to relays for feeders from busbar C.

Select $I_{>>} = 1.2 \cdot 750 = 900 \text{ A}$ and the high set stage time delay as short as possible (approximately 30 ms).

Select $k = 0.10$ from the time curve in Fig 6 and 35.

Low set stage:

$$I_{>} = 300 \cdot \frac{5}{250} = 6 \text{ A}$$

High set stage:

$$I_{>>} = 900 \cdot \frac{5}{250} = 18 \text{ A}$$

Relay 1

The primary setting of the low set stage is:

$$I_{>} = 315 \cdot 1.6 = 500 \text{ A}$$

The relay constitutes a back-up protection for faults which occur up to breaker 3. In the case of faults close to the breaker the safety factor in respect of a two-phase fault will be:

$$\frac{720 \cdot \frac{\sqrt{3}}{2}}{500} = 1.25$$

Select $k = 0.10$ from the time curve in Fig 6 and 35.

As the instantaneous function cannot be used the high set stage has to be blocked.

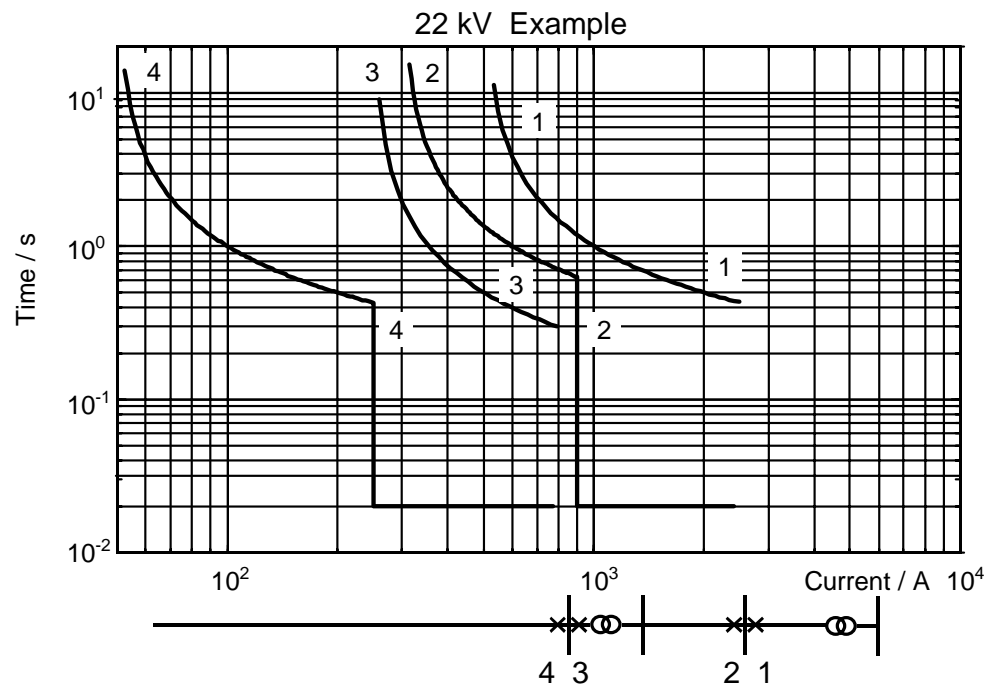

Fig. 6 Current-time characteristics for the studied network

1.2 Earth-fault protection

The demands imposed on the earth fault protection are dependent on system earthing and usually also on national requirements and previous practice.

All electrical power systems have a coupling to earth. The method of how the neutral points of the system are connected to the earth defines the system earthing.

The system earthing can be either unearthed, high-impedance earthed, low-impedance earthed or solidly earthed. The earthing methods will influence the earth-fault current and therefore also the choice of the earth-fault protection. The magnitude of earth-fault current will vary widely from less than one ampere to several kiloamperes depending of the earthing methods. This implies that the demands imposed on the earth fault protection vary considerably.

1.2.1 Earth-fault protection in unearthed or high-impedance earthed system

An unearthed system does not have any neutral-point equipment that influences the earth-fault current. Voltage transformers and surge arresters may connect phase conductors and transformer neutral points to earth. The system is coupled to earth via the distributed capacitance to earth of the overhead lines and cables in the system. In these systems the earth-fault currents are an order of magnitude smaller than the short-circuit currents and the shunt impedances determine the earth-fault currents. An earth-fault with zero fault resistance will give a capacitive earth-fault current and the magnitude is determined of size of the capacitance. Network with small extension can give earth-fault currents that are less than one ampere.

For unearthed or high-impedance earthed systems the residual voltage will be three times the phase voltage all over the system, in case of a phase-to-earth fault with zero fault resistance. Often there are demands on the protections to be able to clear faults even if there is a considerable fault resistance. In Sweden, for example, the earth-fault protections sometimes shall be able to clear faults even if the fault resistance is 5000 ohm. The fault resistance will reduce the residual voltage considerable.

In network with extensive overhead lines and underground cable systems the capacitive earth fault current can be larger than 100 A and cause hazardous potential rise and develop considerable heat at the fault location. It is therefore not acceptable to operate unearthed network with very large capacitive earth-fault currents. It may be necessary to earth the system via special equipment, e.g. compensator reactors, connected to a transformer neutral, in order to reduce the earth fault current. Special equipment, for example neutral point resistors, may be used to enable earth-faults to be cleared selectively and rapidly. In a high-impedance earthed system the neutral-point can be connected to earth via a resistor or both a resistor and a reactor. The shunt impedances of lines and cables to earth and the neutral point impedance determine the earth-fault currents.

It may be necessary to introduce a resistor if the contribution from the short distribution line is too small to operate directional earth-fault relays.

Non-directional earth-fault protection

In some cases and radial system non-directional residual current protections can be used as earth-fault protections. The earth-fault protection has an independent time delay and selectivity is obtained by time-grading the different relays. The current setting normally corresponds to 10-40% of the maximum fault current and is the same for all relays in the system.

In the case of overhead lines, the capacitive current generated by the protected feeder itself, should not exceed 66% of the operate value set on the line protection. For cables, this value should not exceed 30% of the set value. Directional relays should be used for higher values of the capacitive current of the protected feeder.

Depending on the configuration of the system, the different capacitive currents of the objects and the required sensitivity, directional earth-fault protections are often required.

Another application of the non-directional earth-fault protection is to detect cross-country faults. In this case the setting of the relay is higher than the capacitive earth-fault currents of the feeder. This means that this residual current protection does not operate for single-phase earth-faults. During normal operation the residual current is close to zero which means that the setting may be lower than the setting of the overcurrent protection. The current setting can also be set to a very low value but the delay of the function shall be set to a high value to assure selectivity for single phase-to-earth faults.

Directional earth-fault protection

In unearthed or high-impedance earthed systems where the capacitive current from the protected line is large compared to the set operate value, directional residual current protections can be used for earth-fault protection. The relay uses the residual voltage as a polarising quantity. The earth-fault protections contain RXPDK 22H as measuring relay with independent time delay. The relay has a characteristic angle $\alpha = 0^\circ$ or $\alpha = -90^\circ$. The angle is set either by a switch on the front side of the relay or by a binary input. Switching between $\alpha = 0^\circ$ and $\alpha = -90^\circ$ can thus be made externally via remote control or by means of a auxiliary contact in the disconnecter of the neutral point earthing equipment. The relay has a high sensitivity and a setting range down to 3,7 mA.

In unearthed systems, the relay measures the capacitive current and the characteristic angle set to $\alpha = -90^\circ$. In resistance earthed systems, the characteristic angle shall be set to $\alpha = 0^\circ$ and the relay measures the resistive component of the earth-fault current.

In high-impedance earthed system with a neutral point reactor the directional earth-fault protections should measure the resistive component of the earth-fault current to achieve a reliable selectivity. For that reason, a resistor normally has to be connected in parallel with the neutral point reactor to get a sufficiently high active current to the directional relay. The characteristic angle shall be set to $\alpha = 0^\circ$.

The time delay settings of the earth-fault relays are chosen according to the same principles as for the overcurrent relay.

Residual overvoltage protection

The transformer is often provided with a residual overvoltage protection. This protection may be the main earth-fault protection for the busbar in the distribution system and the associated transformer windings. It may also provide back-up protection for the distribution feeders.

The RXPDK 22H has a residual overvoltage function. This can be used to improve the back-up protection. By selecting different time delay, for the different feeders fed from one station, based on the failure rate for the different feeders and the priority of critical loads it is possible to reduce the consequences in case of a back-up fault clearing.

1.2.2 Earth-fault protection in low-impedance earthed system

In a low-impedance earthed system, a separate resistor is connected to a transformer neutral point. The fault current is generated from one point only. Selectivity is then achieved by time-grading the different earth fault relays.

Normally, a sensitivity of 10-30% of the maximum fault current is required and this applies to all relays. An earth fault relay can be included in the neutral point to serve as a supplement and backup protection.

The current setting of the relay is often chosen to correspond with that which the neutral-point transformer can withstand continuously. It is also given a relatively long delay of between 10 and 30 seconds.

1.2.3 Earth-fault protection in solidly earthed system

In solidly earthed systems there is a direct connection between transformer neutral points and the earth. The earth-fault currents can be of the same order of magnitude as the short-circuit currents and the series impedances determine the earth-fault currents. A fault-resistance can reduce the earth-fault currents considerably. Often the residual voltage is very small.

Except for measuring the residual current instead of the phase current the same principles and design of the earth-fault protection can be used in solidly earthed radial systems as for short-circuit overcurrent protection.

In meshed transmission systems distance protections often are used to clear earth-fault. In many cases, the fault resistance is much higher than the resistance that can be covered by an impedance measuring distance relay.

Earth-faults with high fault resistance can be detected by measuring the residual current. This type of protection provides maximum sensitivity to earth-faults with additional resistance.

Directional earth-fault protection is obtained by measuring the residual current and the angle between the residual current and the residual voltage. As a general rule, selectivity, is more easily obtained by using the directional instead of the non-directional earth-fault overcurrent protection. High resistive earth-faults can also be detected by a sensitive directional protection, the limiting condition being that sufficient polarising voltage must be available.

At the relay site, the residual current lags the residual voltage by a phase angle that is equal to the angle of the zero-sequence source impedance. In solidly earthed systems, this angle will be in the range of 40° to nearly 90° . To obtain maximum sensitivity under all conditions, the measuring relay should have a characteristic angle of approximately 65° .

The non-directional RXIDK 2H relay can, in some cases, be used as a simple alternative of earth-fault protection, particular as back-up protection. In this case the function is not directional.

Often a directional earth fault protection function is required. In this application it is not possible to use a voltage memory method to decide the direction because there is no zero-sequence voltage before the fault has occurred. In such cases the directional overcurrent relay RXPDK 23H can be used. It has a sensitive directional measuring and will give a correct operation if the input voltage is more than 0,5 V.

It is often required to clear earth-fault with residual currents of magnitudes which are as low as 50-100 A. Small residual currents normally occur when there are high resistance faults or series faults.

A serial fault can be caused by interruption of one or two phase-conductors with no contact to earth, or pole discrepancy in a circuit-breaker or a disconnecter. The most common type of serial fault is pole discrepancy at operating of the breaker.

A sensitive non-directional inverse time residual overcurrent protection is a suitable solution to get a selective protection in most cases. It is possible to use the standard inverse time characteristics described in section 1.1.2. A logarithmic characteristic is generally the most suitable for the purpose of selectivity, since the time difference is constant for a given ratio between the currents. The logarithmic inverse time characteristic available in the RXIDG 21H relay in the RAIDG protection is designed to achieve optimum selectivity. This relay is used extensively in e.g. the Swedish 400 kV power transmission system. The same type of inverse time-current characteristic should be used for all earth-fault overcurrent protections in the network. Therefore, in networks already equipped with earth-fault overcurrent relays, the best selectivity will normally be achieved by using the same type of characteristic as that in the existing relays.

The logarithmic inverse time characteristic is defined in the formula:

$$t = 5,8 - 1,35 \cdot \ln \frac{I}{I_a}$$

where I_a is the basic current.

The characteristic is shown in fig 40 in section 5.

The selectivity is ensured when the largest infeed is less than 80% of the current on the faulty line. The settings for all objects shall be the same.

To detect high resistive earth faults, a low operating current is required. On the other hand, a low setting will increase the risk for unwanted operation due to unbalance in the network and the current transformer circuits. The minimum operating current of the earth-fault overcurrent protection must be set higher than the maximum false earth-fault current.

The unbalance in the network that causes false earth-fault current is caused mainly by untransposed or not fully transposed transmission lines. In case of parallel lines with strong zero-sequence mutual coupling the false earth-fault current can be still larger. The false earth-fault current is directly proportional to the load current.

In a well transposed system, the false earth-fault current is normally lower than 5% of the line current, except for extremely short parallel lines (less than 5 km), where a higher false earth-fault current may be found.

In case of extremely short or not fully transported parallel lines, the false earth-fault current must be measured or calculated when maximum sensitivity is desired. Generally, 80 A is recommended as a minimum primary operating value for the earth-fault overcurrent protection.

1.2.3.1 Second harmonic restraint operation with RAISB

When energising a solidly earthed power transformer, the residual inrush current can cause unwanted operation of the earth-fault overcurrent protection. In order to avoid restrictions on the settings, a second harmonic restraint relay type RAISB can be used for the earth-fault current protection. It blocks the operation if the residual current contains 20% or more of the second harmonic component.

1.2.4 Connection of earth-fault relay

The current to the earth fault relay can be connected in two different ways, by residual current connected line transformers or by using a separate open core current transformer.

In the case where the current transformers are residual current connected an unbalanced current can appear due to differences in the current transformers. In the event of a short circuit, the unbalanced current can be of such a magnitude as to cause the operation of the earth fault relay. This can be prevented if the operate time of the earth fault relay is extended in relation to that of the short-circuit protection or if an open core current transformer is allowed to feed the earth fault relay.

To reduce the unbalanced current in cases when the current transformers are residual current connected, the current summation must take place as near as possible to the current transformers. No other relays or instruments should be connected. If this cannot be avoided, the load should be symmetric and the burden low.

The directional earth-fault overcurrent relay shall also measure the zero sequence voltage. It is recommended to use the residual voltage measured in a three-phase voltage transformer connected in a broken delta. The residual voltage is three times the zero sequence voltage.

If a complete three-phase voltage transformer group is not available it is possible to use the neutral point voltage measured from a voltage transformer connected to the neutral point. This is a less reliable method and should not be recommended in the first place.

1.3 Demands on the current transformers

To ensure reliable operation of the protection, the following requirements must be fulfilled.

1.3.1 Overcurrent protection

Definite time delay

To avoid failure to operate it must be assured that the current from the saturated current transformer is large enough for operation of the relay. The rated equivalent limiting secondary e.m.f., E_{al} should satisfy the following requirement:

$$E_{al} \geq 2 \cdot I_{set} \cdot [R_{CT} + R_l + Z_r]$$

I_{set} is the current set value of the relay, R_{CT} is the secondary resistance of the secondary winding of the current transformer, R_l is the resistance of the a single secondary wire from the current transformer to the relay and Z_r is the actual burden of the current transformer. It must be observed that we consider only the single length of the secondary wire from the current transformer to the relay. This is valid when we study overcurrent protection in high impedance earthed systems.

Inverse time delay

In the case of overcurrent relays with an inverse time characteristic, it generally applies that saturated current transformers result in longer tripping times. To avoid error in the time delay of the relay the current transformer must not saturate for any possible fault current that can occur. A practical value for RXIDK 2H to chose is to assure that a current, 20 times the current setting of the inverse time function, does not give saturation. The rated equivalent limiting secondary e.m.f., E_{al} should satisfy the following requirement:

$$E_{al} \geq 20 \cdot I_{set} \cdot [R_{CT} + R_l + Z_r]$$

I_{set} is the current set value of the inverse time function, R_{CT} is the secondary resistance of the secondary winding of the current transformer, R_l is the resistance of the a single secondary wire from the current transformer to the relay and Z_r is the actual burden of the current transformer.

For RXIDG

$$E_{al} \geq 40 \cdot I_{set} \cdot [R_{CT} + R_l + Z_r]$$

Instantaneous function

To avoid failure to operate, of the instantaneous function, it must be assured that the current from the saturated current transformer is large enough for operation of the relay. The function should be assured for fault currents at least 1.5-2.0 times the value set on the relay. The margin depends on the time constant of the network. As a rule, the majority of fault points in distribution networks have low time constants and therefore a margin of 1.5 times the set value should be sufficient. The rated equivalent limiting secondary e.m.f., E_{al} should, in this case, satisfy the following requirement:

$$E_{al} \geq 1.5 \cdot I_{set} \cdot [R_{CT} + R_l + Z_r]$$

I_{set} is the current set value of the instantaneous function, R_{CT} is the secondary resistance of the secondary winding of the current transformer, R_l is the resistance of the a single secondary wire from the current transformer to the relay and Z_r is the actual burden of the current transformer.

1.3.2 Limiting secondary e.m.f, E_{al} - Calculation example

Current transformer data

Ratio	50-100/5/5 A		
Core 1	5 VA	Fs = 10	$R_{CT} = 0.05$
Core 2	30 VA	Kssc =10.0 (ALF)	$R_{CT} = 0.07$
Connected	100/5/5 A		
Relay $I_r = 5$ A	Burden 0.3 VA		

Data for secondary conductors from current transformers to relay:

Cross section = 2.5 mm² Length of copper = 25 m (single length).

Burden, relay = 0.3 / 5² = 0.012 ohm.

Burden, secondary conductor = $\rho \cdot \frac{L}{a} = 0.0175 \cdot \frac{25}{2.5} = 0.175 \Omega$.

It should be noted that the resistance of the secondary conductors is the main burden of the current transformer circuit.

The rated equivalent limiting secondary e.m.f., E_{al} can be calculated as:

$$E_{al} = K_{ssc} \cdot I_n \cdot \left[R_{CT} + \frac{S_n}{I_n^2} \right]$$

$$E_{al} = 10 \cdot 5 \cdot \left[0.07 + \frac{30}{5^2} \right] = 63.5 V$$

K_{ssc} is the rated symmetrical short circuit current factor, I_n is the rated secondary current of the current transformer, R_{CT} is the secondary resistance of the secondary winding of the current transformer, and S_n is the rated burden of the current transformer.

If the relay has an instantaneous current setting of 2000 A (primary) corresponding to 100 A (secondary), the demand for E_{al} will be:

$$E_{al} \geq 1.5 \cdot 100 \cdot [0.07 + 0.175 + 0.012] = 38.5 V$$

As we can see the requirement on the current transformer is fulfilled.

In solidly earthed systems which are subject to fault currents of high magnitude, the total resistance of the current transformer secondary circuit must be taken into consideration; thus, according to the example, $L = 2 \cdot 25 \text{ m}$, if it is required to have a phase relay operate even in the event of earth faults. The secondary e.m.f. E_{al} must then be adapted to the maximum earth fault current, the total resistance ($2 \cdot 25 \text{ m}$) and the maximum short-circuit current and a single length ($1 \cdot 25 \text{ m}$).

If an earth-fault relay, residual current connected to the CT:s, is incorporated in the measuring circuit, as shown in Fig 7, the earth-fault relay must also be taken into consideration.

1.3.3 Earth-fault protection

When transformers are residual current connected, certain magnetization losses arise and, in conjunction with the commissioning of an installation, the primary operate value should be checked to ensure that it is correct.

The demand on the current transformers of the sensitive directional earth-fault relay is, that the composite error should be so small, that measuring of the active component of the earth-current is not influenced by the capacitive component. This is secured by checking the efficiency factor. In cable networks with risks for intermittent earth-faults, the current transformer has to be dimensioned so that the direct current component of the earth current would not saturate the transformer.

Efficiency factor

In isolated and high-impedance earthed systems, the fault current fed to the earth-fault relays is normally small and relays with low operating current are used. In this case, the efficiency factor of the relay should be checked.

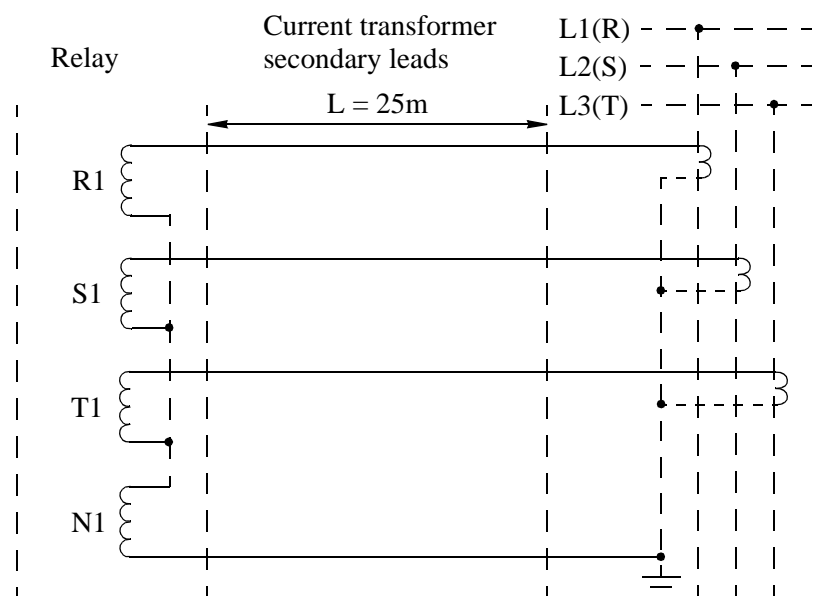

Fig. 7 Equivalent circuit for current transformer to earth-fault relay.

The efficiency factor is defined as:

$$\eta = \frac{I_r}{I_N} \cdot N_{CT} \cdot 100 \%$$

where:

I_r = current supplied to the relay

I_N = primary earth-fault current

N_{CT} = current transformer ratio

The efficiency factor can be calculated from the formula:

$$\eta = 100 \cdot \frac{Z_m}{Z_m + Z_2 + C \cdot (Z_L + Z_r)} \%$$

where

X_m = magnetizing impedance of the current transformer(s)

Z_2 = resistance of the current transformer secondary winding plus resistance of wires up to the interconnection (per phase)

Z_L = resistance of wires up to the earth-fault relay (loop resistance)

Z_r = impedance (resistance) of the measuring circuit of the relay

C = 1 for cable current transformers

C = 3 for residual connected current transformers

It should be observed that the magnetizing impedance varies with the voltage. The impedance Z_m at the secondary voltage which gives relay operation is inserted in the formula. If the angle of the impedance Z_m is not known, the value 45 degrees (lagging) can be assumed.

The requirement on η is:

$\eta > 80\%$ for earth-fault relays

$\eta > 90\%$ for directional earth-fault relays

1.4 Other applications

The great functionality of the different relays facilitate the use of them in a great number of applications. For example the RXPDK 22H relay has an over- or under-voltage function that can be used separately or in combination with the overcurrent function. This can be useful in generator protection applications.

Overcurrent relays with directional function can be used for protection schemes in, transmission systems, using communication. The schemes that can be used are the following:

- Permissive underreach scheme. When an instantaneous function of a directed overcurrent relay give a trip at one line end an acceleration signal is sent to the remote line terminal. This signal together with a directional criterium from a directed relay will give a trip signal also at the second line terminal.
- Permissive overreach scheme. This scheme is similar to the under-

reach scheme except that the criterium to send an acceleration signal is only the directional criterium of the relay.

- Blocking scheme. The directional overcurrent relay at the line terminal will send a blocking signal in case of a fault in the reverse direction. In each line end there is also a directed overcurrent function with a delayed trip function. If a blocking signal is received this trip function will be blocked.

1.5 Frequency ranges

The RXIDK 2H relay is provided with optional filters. The standard 50-60 Hz relay has a flat frequency response characteristic allowing its use over a wide frequency range. The other options are 50-60 Hz sharp, 150-180 Hz sharp and 40-2000 Hz flat.

The option 50-60 Hz sharp is used in applications where measuring of the fundamental frequency is required without influence of the harmonics. For example this can be the case for protection of capacitor banks.

The 150-180 Hz sharp is used in applications where only the third harmonics shall be measured.

The filter 40-2000 Hz flat is suitable in applications where the thermal stresses shall be considered and the fault current contains harmonics of higher order. This can be the situation if the load contains non-linear objects or equipment that include semiconductor e. g. converters, rectifier and regulators for motors.

The RXIDK 2H relay is also available in a special $16^{2/3}$ Hz version for application in railway system.

2 Measurement principles

The RXIDK 2H, RXIDG 21H, RXPDK 21H, RXPDK 22H and RXPDK 23H relays constitutes the measuring units of RAIDK, RAIDG, RACIK and RAPDK. For setting of operate values and relays/LED's functions, see section 7.

When the processor starts it executes a self test sequence, if the processor fails to start in a proper way the LED's will indicate by flashing according to Fig. 8 or the "In service" LED will not be lit. The program in the micro-processor is executed in a fixed loop with a constant looptime. The loop is supervised by an internal watch dog which initiates a program restart if the program malfunctions.

Test sequence:	Test error indication:
Config registers	All LED's flash in clockwise rotation
RAM	Left red LED flashes
ROM	Right red LED flashes
A/D	Both red LED:s flash

Fig. 8 Self test error indication of the RXIDK 2H, RXIDG 21H and the RXPDK 21/22H/23H relays

2.1 The RXIDK 2H and RXIDG 21H relays

The functional diagram in Fig. 9 and Fig. 10 illustrates the mode of operating for the RXIDK 2H and RXIDG 21H relays.

To provide a suitable voltage for the electronic measurement circuits the relays are provided with an input-transformer. The output-current of the transformer is shunted via dip-switches before it is filtered with a 4th order bandpass filter. The relays can be ordered with different filters with centre frequencies according to chapter 8.

The voltage is rectified before it is sampled with a sample rate of 1000 samples/s. The voltage ripple is then reduced with a moving average filter. The starts functions operates when the current has reached the set operate current value. The I> stage can be set to inverse-time delay or definite-time delay. For the I>> stage only definite-time delay is available (only RXIDK 2H).

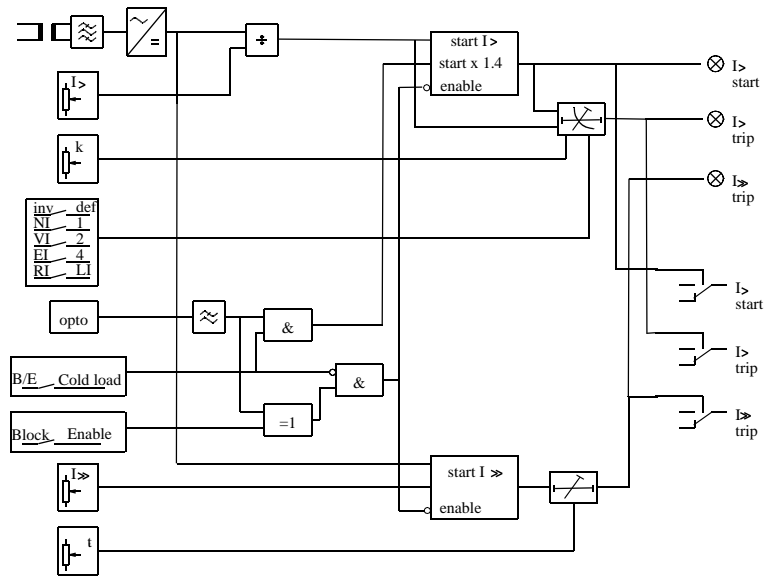

Fig. 9 Simplified functional diagram of the RXIDK 2H relay

The binary input, which can be used for remote blocking or enabling of the start units, is galvanically separated from the electronic measurement circuits with an opto-coupler.

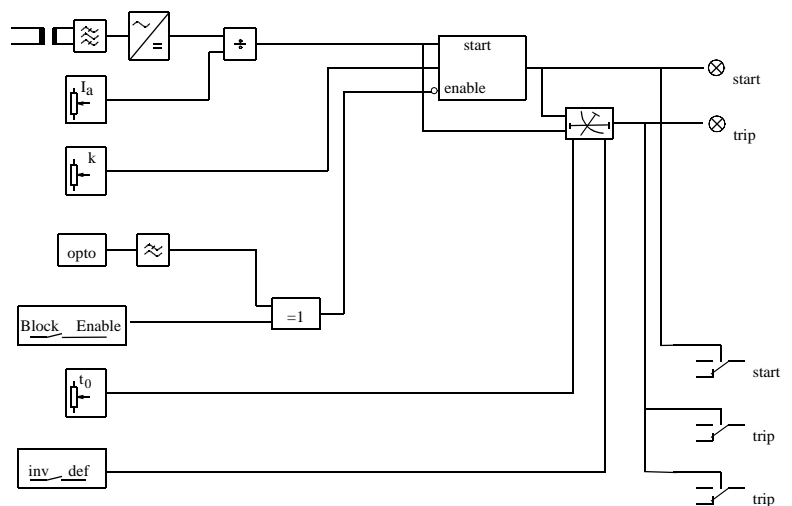

Fig. 10 Simplified functional diagram of the RXIDG 21H relay

2.2 The RXPDK 21H, RXPDK 22H and RXPDK 23H relays

The simplified functional diagram in Fig. 12, 13, 15 and 18 illustrates the mode of operating for the RXPDK 21H, RXPDK 22H and RXPDK 23H relays.

To provide a suitable voltage for the electronic measurement circuits the relays are provided a current-transformer and a voltage-transformer. The voltage from the current-transformer is shunted via dip-switches before it is filtered with a 4th order bandpass filter. The voltage from the voltage-transformer is filtered with a 4th order lowpass filter with a cut-off frequency equal to 140 Hz to reduce influence of harmonics.

The filtered values are applied to zero detectors and a new phase-angle is calculated in the microprocessor every zero-crossing.

The current and voltage values are filtered with a moving average filter to reduce ripple. The phase angle φ is positive when I lags U.

2.2.1 The RXPDK 21H relay

The RXPDK 21H function characteristic is shown in Fig. 11. The RXPDK 21H start $I_{\alpha>}$ unit operates when $I \times \cos(\varphi - \alpha)$ reaches the set operate value. The characteristic angle α , positive when I lags U, is settable, -12° and $+12^\circ$ or -120° and $+120^\circ$.

When the input voltage U drops below 5 V the voltage memory is activated. The phase angle is frozen after 100 ms and resets when the start function resets.

When $U = 0$ before the overcurrent starts e.g. at switching on a line, the relay will operate as follows:

- $U < 5$ V: non-directional operation
- $U > 5$ V: non-directional operation during the first 200 ms and then directional operation

An alternative version of RXPDK 21H uses dip-switch 9 to select directional or non-directional operation for the low set $I_{\alpha>}$ stage. ($0.1 \times \alpha$ or $1 \times \alpha$ selection is not available on this version).

For the $I_{\alpha>}$ stage, the different inverse-time delays or definite-time delay ranges are available.

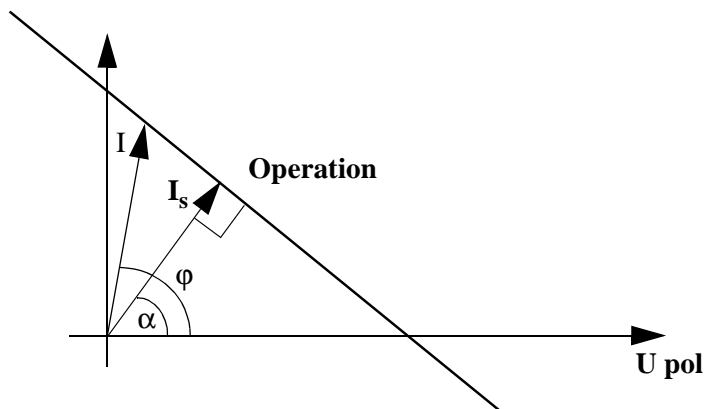

Fig. 11 Function characteristic of the RXPDK 21H relay.

There are two binary inputs on the relay, one for blocking of the directional time delayed low set stage and the other for remote resetting of the “Trip $I_{\alpha>}$ ” and “Trip $I_{>>}$ ” LED’s. The binary inputs are galvanic separated from the electronics with a opto-coupler.

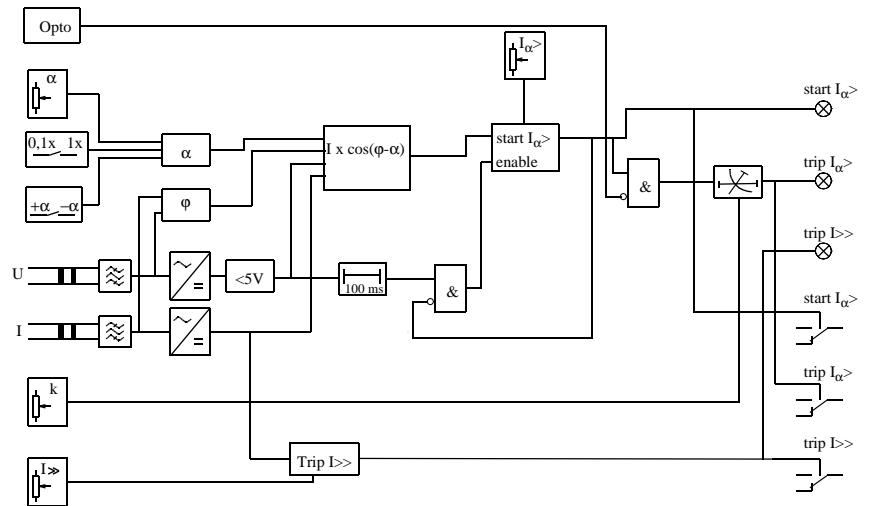

Fig. 12 Simplified functional diagram of the RXPDK 21H relay

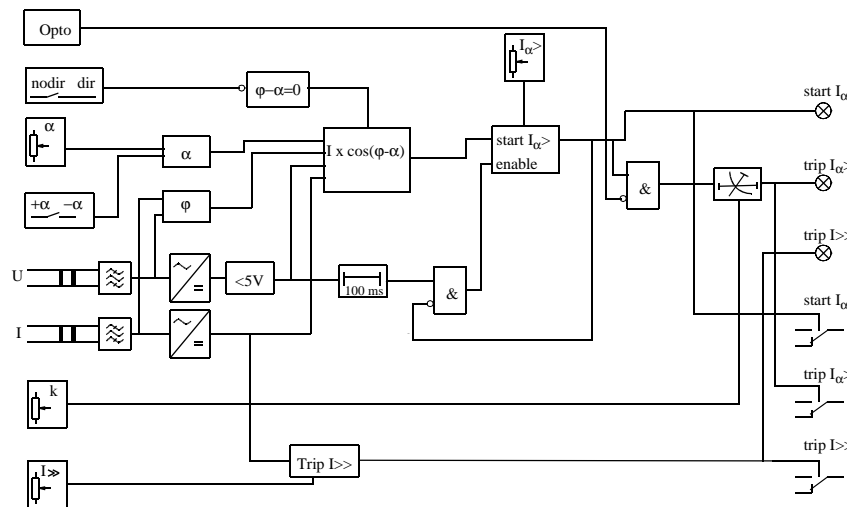

Fig. 13 Simplified functional diagram of the alternative RXPDK 21H relay with the directional/non-directional switch

The reset button has two functions, LED check and resetting the LED’s. When the button is depressed, the “Start $I_{\alpha>}$ ”, “Trip $I_{\alpha>}$ ” and “Trip $I_{>>}$ ” LED’s are lit and the “In service” LED is switched off, in order to check the LED’s. When the button is released the “Start $I_{\alpha>}$ ”, “Trip $I_{\alpha>}$ ” and “Trip $I_{>>}$ ” LED’s are reset to show the actual status and “In service” LED is relit.

2.2.2 The RXPDK 22H relay

The RXPDK 22H start I> unit operates according to fig. Fig. 14.

	switch 8 = U>,Iα>	switch 8 = U<,I>
switch 6 = U enabl I	$I \times \cos(\varphi - \alpha) \geq I>$ and $U_N \geq U>$	$I \geq I>$ and $U_N \leq U<$
switch 6 = I indep U	$I \times \cos(\varphi - \alpha) \geq I>$ and $U_N \geq 5 V$	$I \geq I>$

Fig. 14 Start conditions for the RXPDK 22H start I> function

The characteristic angle α can be set to 0° or -90° with switch 5. The function characteristics can be set with switch 4 according to Fig. 16. The I> stage is provided with definite-time delay.

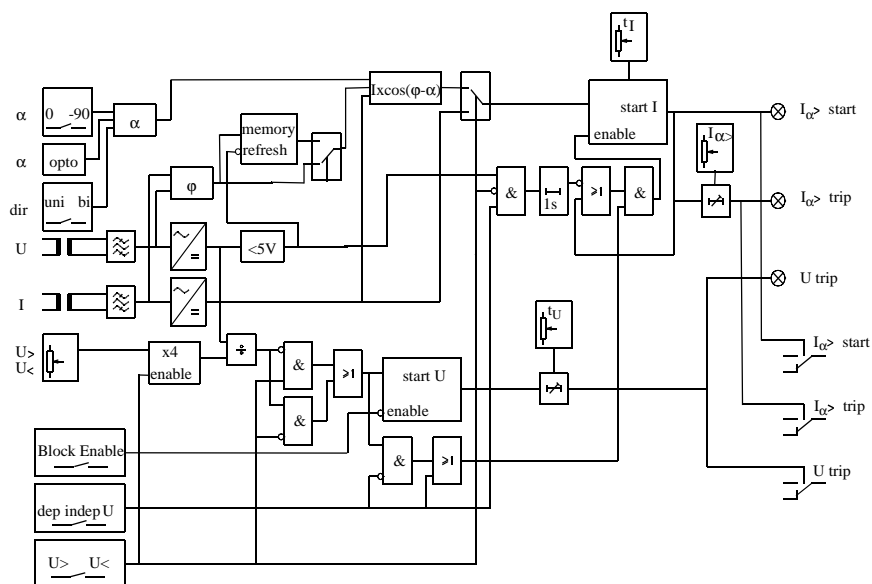

Fig. 15 Simplified functional diagram of the RXPDK 22H relay

The relay is also provided with a built-in backup protection in case the ground fault current does not reach the set value. The neutral-point voltage stage operates when the voltage reaches the set operate value. The voltage stage is provided with definite time-delay. The voltage stage can be disabled with switch 7. The stage can be set to over-voltage or under-voltage trip by switch 8.

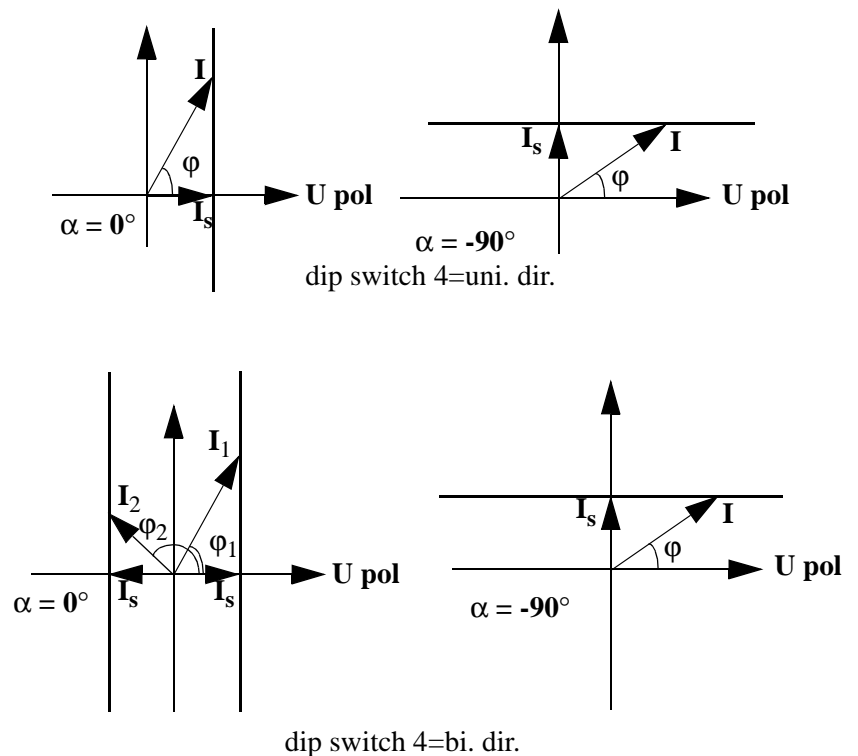

Fig. 16 Function characteristics for the RXPDK 22H relay

There are two binary inputs on the relay. The binary input Bin 1 toggles the characteristic angle from 0° to -90° or from -90° to 0° when activated. The binary input Bin 2 is used for remote resetting of the “Trip I>” and “Trip U” LED’s. The binary inputs are galvanically separated from the electronics with an opto-coupler.

The reset button has two functions, LED check and resetting the LED’s. When the button is depressed, the “Start I>”, “Trip I>” and “Trip U” LED’s are lit and the “In service” LED is switched off, in order to check the LED’s. When the button is released the “Start”, “Trip I>” and “Trip U” LED’s are reset to show the actual status and “In service” LED is relit.

2.2.3 The RXPDK 23H relay

The RXPDK 23H start $I_{\alpha>}$ directional stage operates when the two conditions, $I \geq I_{\alpha>set}$ and $0^\circ \geq \varphi \geq 140^\circ$, is fulfilled (see Fig. 17). For the $I_{\alpha>}$ stage, inverse time delay or definite time delay is available. The directional stage is operational if the input voltage is more than 0,5 V.

The non-directional stage operates when $I \geq I_{>>set}$ and is provided with a settable definite time delay up to 10 seconds.

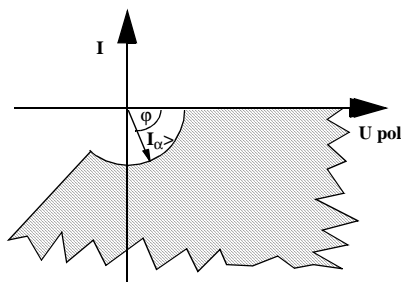

Fig. 17 Function characteristics for the RXPDK 23H $I_{\alpha>}$ function.

There are two binary inputs on the relay, one for blocking or enabling of the delayed trip functions and the other for remote resetting of the “Trip $I_{\alpha>}$ ” and “Trip $I_{>>}$ ” LED’s. The binary inputs are galvanic separated from the electronics with a opto-coupler.

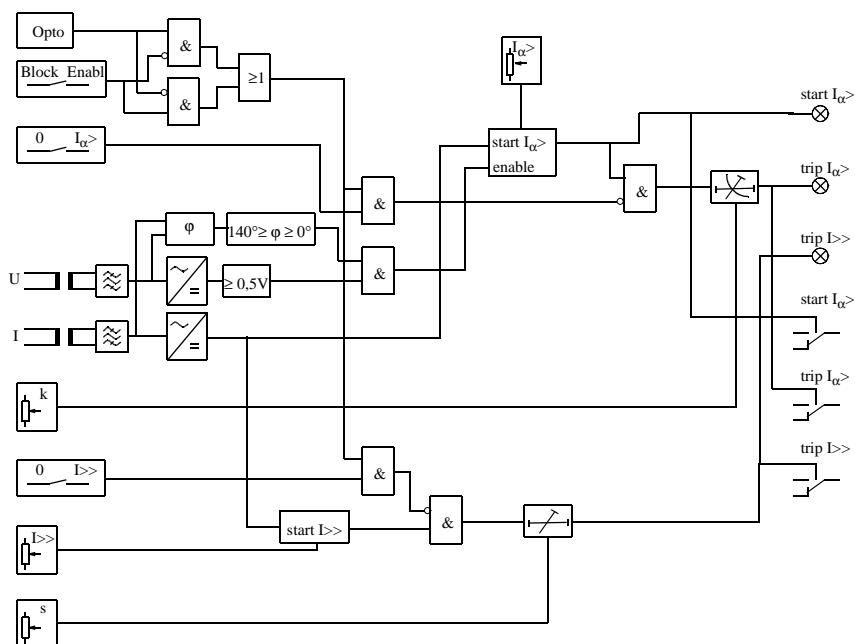

Fig. 18 Simplified diagram of the RXPDK 23H relay

The reset button has two functions, LED check and resetting the LED’s. When the button is depressed, the “Start $I_{\alpha>}$ ”, “Trip $I_{\alpha>}$ ” and “Trip $I_{>>}$ ” LED’s are lit and the “In service” LED is switched off, in order to check the LED’s. When the button is released the “Start”, “Trip $I_{\alpha>}$ ” and “Trip $I_{>>}$ ” LED’s are reset to show the actual status and “In service” LED is relit.

3 Design

The protections RAIDK, RAIDG, RAPDK and RACIK are designed in a number of variants for one-, two- or three-phase overcurrent protections and/or earth-fault protection. Each protection is available with or without test switch RTXP 18, DC-DC converter RXTUG 22H or tripping relay RXME 18.

All protections are built up by modules in the COMBIFLEX® modular system mounted on apparatus bars. The connections to the protections are done by COMBIFLEX® socket equipped leads.

The type of modules and their physical position and the modular size of the protection are shown in the *Buyer's Guide* and in the Circuit Diagram of respective protection. One or more of the following modules can be included.

3.1 Test switch

The test switch RTXP 18 is a part of the COMBITEST testing system described in the *Buyer's Guide*, document no.1MRK 512 001-BEN. A complete secondary testing of the protection can be performed by using a test-plug handle RTXP 18 connected to a test set. When the test-plug handle is inserted into the test switch, preparations for testing are automatically carried out in a proper sequence, i.e. blocking of tripping circuits, short-circuiting of current circuits, opening of voltage circuits and making the protection terminals available for secondary testing. RTXP 18 has the modular dimensions 4U 6C.

All input currents can be measured by a test plug RTXMM connected to an ammeter. The tripping circuits can be blocked by a trip-block plug RTXBB and the protection can be totally blocked by a block-plug handle RTXFB 18.

3.2 DC-DC converter

The DC-DC converter RXTUG 22H converts the applied battery voltage to an alternating voltage which is then transformed, rectified, smoothed and in this application regulated to ± 24 V DC. The auxiliary voltage is in that way adopted to the measuring relays. In addition, the input and output validates will be galvanically separated, which contributes to damping of possible transients in the auxiliary voltage supply to the measuring relays. The converter has a built-in signal relay and a green LED for supervision of the output voltage.

RXTUG 22H has the modular dimensions 4U 6C. It is described in the *Buyer's Guide*, document no. 1MRK 513 001-BEN.

3.3 Measuring relays

RXIDK 2H

The time-overcurrent relay RXIDK 2H consists mainly of an input transformer for current adoption and isolation, filter circuits, digital-analog converter, microprocessor, MMI consisting of a programming switch and potentiometers for setting and LEDs for start, trip and in service indications, and three output relays, each with a change-over contact, for the

start and trip functions of the low set stage and for the trip function of the high set stage respectively. The relay has also a binary input by which the operation can be enabled or blocked or the operate value of the low set stage increased by 40%.

A short circuiting connector RTXK is mounted on the rear of the terminal base and will automatically short-circuit the current input when the relay is removed from its terminal base.

RXIDK 2H has the modular dimensions 4U 6C.

RXIDG 21H

The time-overcurrent relay RXIDG 21H consists mainly of an input transformer for current adoption and isolation, filter circuits, digital-analog converter, microprocessor, MMI consisting of a programming switch and potentiometers for setting and LEDs for start,trip and in service indications, and three output relays, each with a change-over contact, for the start and trip functions. The relay has also a binary input by which the operation can be enabled or blocked.

A short circuiting connector RTXK is mounted on the rear of the terminal base and will automatically short-circuit the current input when the relay is removed from its terminal base.

RXIDG 21H has the modular dimensions 4U 6C.

RXPDK 21H

The directional time-overcurrent relay RXPDK 21H consists mainly of two input transformers for current and voltage adoption and isolation, filter circuits, digital-analog converter, microprocessor, MMI consisting of a programming switch and potentiometers for setting and LEDs for start,trip and in service indications, and three output relays, each with a change-over contact, for the start and trip functions of the directional stage and for trip function of the non-directional high set stage. The relay has also two binary inputs for remote resetting of LED indications and for changing the directional function to be non- directional.

A short circuiting connector RTXK is mounted on the rear of the terminal base and will automatically short-circuit the current input when the relay is removed from its terminal base.

RXPDK 21H has the modular dimensions 4U 6C.

RXPDK 22H

The directional time-overcurrent relay RXPDK 22H consists mainly of two input transformers for current and voltage adoption and isolation, filter circuits, digital-analog converter, microprocessor, MMI consisting of a programming switch and potentiometers for setting and LEDs for start,trip and in service indications, and three output relays, each with a change over contact, for the start and trip functions of the directional stage and for trip function of the over- or under-voltage function. The relay has also two binary inputs for remote resetting of LED indications and for changing the characteristic angle from 0 to -90 or vice versa.

A short circuiting connector RTXK is mounted on the rear of the terminal base and will automatically short-circuit the current input when the relay is removed from its terminal base.

RXPDK 22H has the modular dimensions 4U 6C.

RXPDK 23H

The directional time-overcurrent relay RXPDK 23H consists mainly of two input transformers for current and voltage adoption and isolation, filter circuits, digital-analog converter, microprocessor, MMI consisting of a programming switch and potentiometers for setting and LEDs for start, trip and in service indications, and three output relays, each with a change over contact, for the start and trip functions of the directional stage and for trip function of the non-directional high current function. The relay has also two binary inputs for remote resetting of LED indications and for blocking or enabling of the trip functions.

A short circuiting connector RTXK is mounted on the rear of the terminal base and will automatically short-circuit the current input when the relay is removed from its terminal base.

RXPDK 23H has the modular dimensions 4U 6C. It is described in the *Buyer's Guide*, document no. 1MRK 509 007-BEN.

Tripping relay

The auxiliary relay RXME 18 is used as tripping relay. It has two heavy duty make contacts and a red flag. The flag will be visible when the armature picks-up and it is manually reset by a knob in the front of the relay. Typical operate time is 35 ms.

RXME 18 has the modular dimensions 2U 6C. It is described in the *Buyer's Guide*, document no. 1MRK 508 015-BEN.

4 Setting and connection

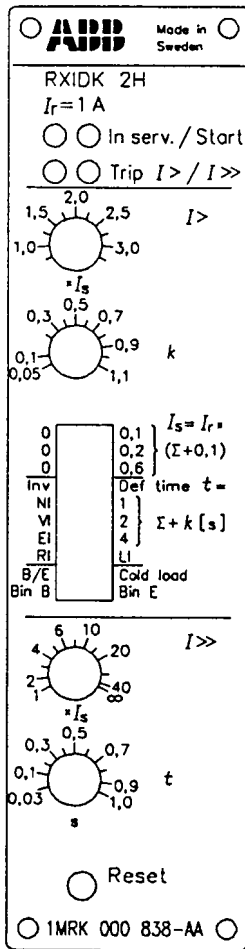

1MRK 000 117-35

Fig. 19 Front layout

RXIDK 2 H

Rated current of the relay, I_r (available variants: 0,2 A, 1 A or 5 A)

LED indicators:

- In serv. (green): indicates relay in service.
- Start (yellow): indicates operation of $I>$ (no time delay).
- Trip $I>$ (red): indicates operation of $I>$ after the set time delay.
- $I>>$ (red): indicates operation of $I>>$ after the set time delay.

$I>$ (Low set stage):

Potentiometer (P1) for setting of the operate value for the function $I>$.

Potentiometer (P2) for setting of the inverse time factor k or definite time delay t for the function $I>$.

10-pole programming switch (S1) for setting of the scale constant I_s , time delay characteristic and the binary input function.

$I>>$ (High set stage):

Potentiometer (P3) for setting of the operate value for the function $I>>$.

Potentiometer (P4) for setting of the definite time-delay for the function $I>>$. *)

Reset push-button.

*) The setting ranges are different for the different variants of the relay
All variants except 16 Hz: 30 ms - 1,0 s
16 Hz: 60 ms - 1,0 s
16 Hz alternative version: 60 ms - 5,0 s

CONNECTION:

The RXIDK 2H relay requires a dc-dc converter type RXTUG for the auxiliary voltage supply ± 24 V. Connection of voltage RL shall be made only if the binary input is used.

The relay is delivered with a short-circuiting connector RTXK for mounting on the rear of the terminal base. This connector will automatically short-circuit the current input when the relay is removed from its terminal base.

NOTE! The auxiliary voltage supply should be disconnected or the output circuits should be blocked to avoid the risk of unwanted alarm or tripping, before the relay is plugged into or withdrawn from its terminal base

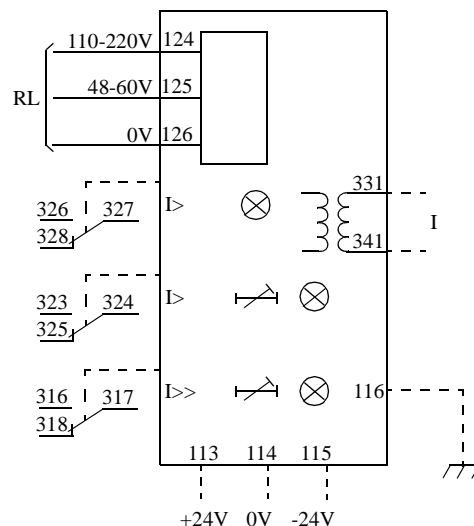

Fig. 20 Terminal diagram RXIDK 2H

SETTING

All settings can be changed while the relay is in normal service.

1. Setting of the scale constant I_s .

I_s is common for both the low set stage $I>$ and the high set stage $I>>$.

It is set with the programming switches S1:1, S1:2 and S1:3, from 0,1 to 1,0 times the rated current I_r .

2 Setting of the low set stage operate value $I>$.

The operate value is set with potentiometer P1 according to $I> = P1 \times I_s$

3. The low set stage time delay.

The low set stage has six time characteristics, which are programmed on the programming switches S1:4 to S1:8.

Definite-time delay.

Set the programming switch S1:4 to position "Def.time t=", where $t = \Sigma + k$. Switches S1:5 to S1:7 are used for the main adjustment $\Sigma = 0 - 7$ s, and potentiometer P2 is used for the fine adjustment $k = 0,05 - 1,1$ s. The minimum time delay is 50 ms and the maximum time delay is 8,1 s.

When selecting this characteristic, the position of switch S1:8 ("RI" or "LI") has no influence.

Inverse-time delay.

Set switch S1:4 in position "Inv". The inverse-time characteristic is selected with the switches S1:5 to S1:8 (NI = Normal Inverse, VI = Very Inverse, EI = Extremely Inverse, RI = ASEA RI-relay Inverse, LI = Long-time Inverse).

By setting the selector switch S1 a precedence order is applied, from top (S1:5) to bottom (S1:8). That is, if the "NI" characteristic is selected (the switch in the left hand side position), it overrides the settings of switches S1:6 to S1:8. Another example; if the "LI" characteristic shall be used, the switches S1:5 to S1:8 must be in the right hand position.

After setting the inverse-time characteristic, the time delay is determined by the inverse time factor k, which is adjusted with potentiometer P2.

4. Setting the high set stage $I>>$ operate value.

The operate value is set with potentiometer P3 according to $I>> = P3 \times I_s$.

This function can be blocked by setting potentiometer P3 to " ∞ "

5. The high set stage time delay.

The time delay for the high set stage ($I>>$) has a definite-time characteristic. The setting is done with potentiometer P4.

6. The binary input.

The binary input is programmable for enabling the relay, blocking the relay or to increase the operate value of the low set stage $I>$ by 40% ("Cold load"). The function is activated when a voltage RL is applied to the binary input.

The settings are done on programming switches S1:9 and S1:10 as follows:

Enable function;

S1:9 in position "B/E" and S1:10 in position "Bin E"

Block function;

S1:9 in position "B/E" and S1:10 in position "Bin B"

Cold load;

S1:9 in position "Cold load". (S1:10 has no influence)

Note! The setting shall be in "B/E" and "Bin B" positions, if the binary input is not used.

INDICATION

There are four LED indicators. The trip indicators seal-in and are reset manually by the "Reset" push-button, while the start indicator resets automatically when the relay resets.

When the "Reset" push-button is depressed during normal operating conditions, all LEDs except "In serv." will light up.

When connecting RXIDK 2H to the auxiliary voltage, the relay performs a self test. The "In serv." LED is alight, after performing the self test and when the relay is ready for operation. In case of a fault, the LEDs will start flashing.

TRIPPING AND START OUTPUTS

The RXIDK 2H relay has one start and one tripping output for the low set stage, and one trip output for the high set stage. Each output is provided with one change-over contact. All outputs reset automatically when the current decreases to a value below the resetting value of the relay.

ESD

The relay contains electronic circuits which can be damaged if exposed to static electricity. Always avoid to touch the circuit board when the relay cover is removed during the setting procedure.

RXIDG 21H

Rated current of the relay, I_r (0,2 A)

LED indicators:

In serv. (green): indicates relay in service.

Start I> (yellow): indicates function of I> (no time delay).

Trip I> (red): indicates operation of I> after the set time delay.

Potentiometer (P1) for setting of the basic current value I_a .

5-pole programming switch (S1) for setting of the scale constant I_s , time delay characteristic and the binary input function.

Potentiometer (P2) for setting of the operate value for the function I>.

Potentiometer (P3) for setting of the time-delay t_0 .

Reset push-button.

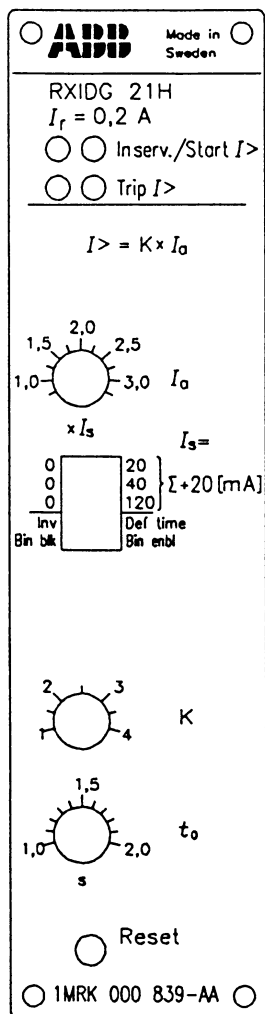

1MRK 000 117-39

Fig. 21 Front layout

INSTALLATION:

The RXIDG 21H relay requires a dc-dc converter type RXTUG for auxiliary supply ± 24 V. Connection of RL shall be made only if the binary input is used.

The relay is delivered with a short-circuiting connector RTXK for mounting on the rear of the terminal base. This will automatically short-circuit the current input when the relay is removed from the terminal base.

NOTE! The auxiliary voltage supply should be interrupted or the output circuits should be blocked to avoid the risk of unwanted alarm or tripping, before the relay is plugged into or withdrawn from its terminal base.

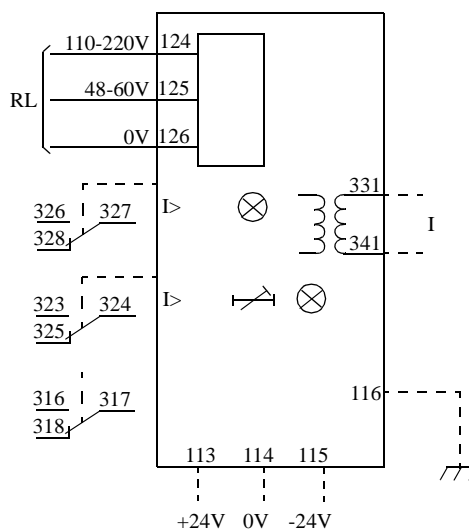

Fig. 22 Terminal diagram RXIDG 21H

SETTINGS:

All settings can be changed while the relay is in normal service.

1. Setting of the scale constant I_s .

I_s is set with the programming switches S1:1, S1:2 and S1:3, between 20 - 200 mA.

2 Setting of the basic current I_a .

The basic currents set with potentiometer P1 according to $I_a = P1 \times I_s$

3. Setting of the operate value $I>$.

The operate value is set with potentiometer P2 according to $I> = K \times I_a$. $I>$ is the start operate current for the definite-time function and for the inverse-time function. The operate characteristic of the relay is shown in figure x

4. The time delay characteristic.

The relay has two time characteristics, which are programmed on the programming switch S1:4.

Definite-time delay.

Set the programming switch S1:4 to position "Def.time". Potentiometer P3 is used for the time delay which can be set between 1 and 2 s.

Inverse-time delay.

Set switch S1:4 in position "Inv". The inverse-time delay is determined by the I_a setting. The minimum operation time t_0 is set on potentiometer P3 (1 - 2 s).

5. The binary input.

The binary input is programmable for enabling the relay, blocking the relay. The settings are done on the programming switch S1:5. The function is activated when a voltage RL is applied to the binary input.

The settings shall be in "Bin blk" position, if the binary input is not used.

INDICATION

There are four LED indicators. The trip indicators seal-in and are reset manually by the "Reset" push-button, the start indicator resets automatically when the relay resets.

When the "Reset" push-button is depressed during normal operating conditions, all LEDs except "In serv." will light up.

When connecting RXIDG 21H to the supply voltage, the relay performs a self test. The "In serv." LED is alight, after performing the self test and when the relay is ready for operation. In case of a fault, the LEDs will start flashing.

TRIPPING AND START OUTPUTS

The RXIDG 21H relay has one start and two tripping outputs. Each output is provided with one change-over contact. All outputs reset automatically when the current decreases to a value below the resetting value of the relay.

ESD

The relay contains electronic circuits which can be damaged if exposed to static electricity. Always avoid to touch the circuit board when the relay cover is removed during the setting procedure.

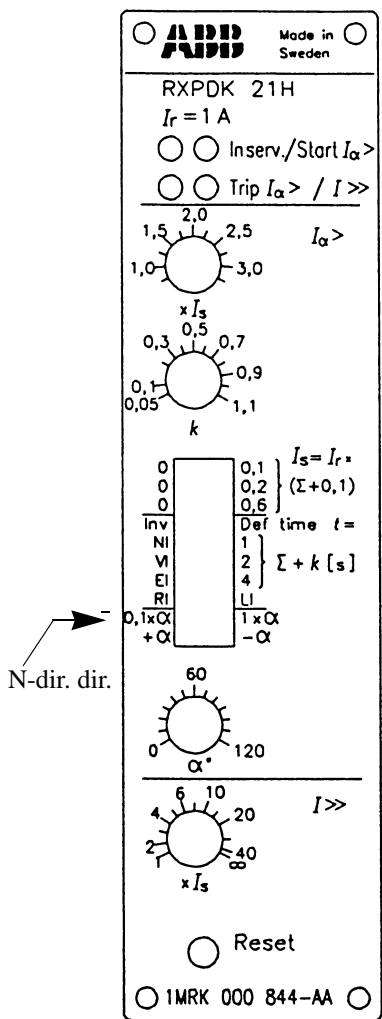

1MRK 000 117-48

Fig. 23 Front layout

CONNECTION:

The RXPDK 21H relay requires a dc-dc converter type RXTUG for auxiliary voltage supply ± 24 V. Connection of the voltage RL shall be made only when the binary input is used.

The relay is delivered with a short-circuiting connector RTXK for mounting on the rear of the terminal base. This connector will automatically short-circuit the current input when the relay is removed from its terminal base.

NOTE! The auxiliary voltage supply should be interrupted or the output circuits should be blocked to avoid the risk of unwanted alarm or tripping, before the relay is plugged into or withdrawn from its terminal base.

NOTE! The auxiliary voltage supply should be interrupted or the output circuits should be blocked to avoid the risk of unwanted alarm or tripping, before the relay is plugged into or withdrawn from its terminal base.

RXPDK 21H

Rated current of the relay, I_r (available variants: 1 A or 5 A)

LED indicators:

In serv. (green): indicates relay in service.
Start $I_{\alpha>}$ (yellow): indicates operation of $I_{\alpha>}$ (no time delay).
Trip $I_{\alpha>}$ (red): indicates operation of $I_{\alpha>}$ after the set time delay.
 $I_{>>}$ (red): indicates operation of $I_{>>}$ after the set time delay.

$I_{\alpha>}$ (Low set directional stage):

Potentiometer (P1) for setting of the operate value for the function $I_{\alpha>}$.

Potentiometer (P2) for setting of the inverse time factor k or definite time delay t for the function $I_{\alpha>}$.

10-pole programming switch (S1) for setting of the scale constant I_s , time delay characteristic and characteristic angle α .

Note: In alternative version switch S:9 for setting non-dir. or dir. operation

Potentiometer (P3) for setting of the characteristic angle α for the function $I_{\alpha>}$.

$I_{>>}$ (High set non-directional stage):

Potentiometer (P4) for setting of the operate value for the function $I_{>>}$.

Reset push-button.

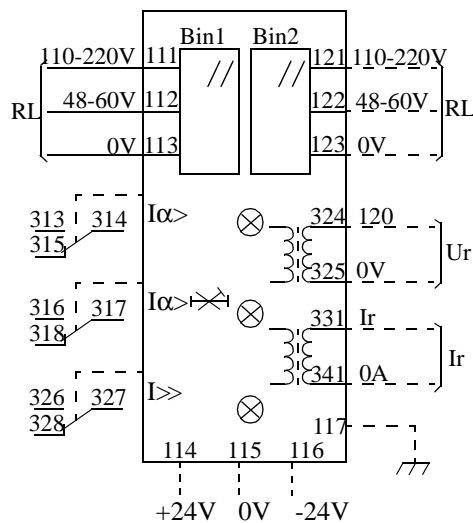

Fig. 24 Terminal diagram RXPDK 21H

SETTINGS:

All settings can be changed while the relay is in normal service.

1. Setting of the scale-constant I_s .

I_s is common for both directional stage $I_{\alpha>}$ and the high set stage $I_{>>}$.

It is set with the programming switches S1:1, S1:2 and S1:3, from 0,1 to $1,0 \times$ the rated current I_r .

2 Setting of the directional stage $I_{\alpha>}$ operate value.

The operate value is set with potentiometer P1 according to $I_{\alpha>} = P1 \times I_s$. (The directional stage operates for $I \times \cos(\varphi - \alpha) > I_{\alpha>}$)

3. The directional stage time delay.

The directional stage has six time characteristics, which are programmed on the programming switches S1:4 to S1:8.

Definite-time delay.

Set the programming switch S1:4 to position "Def time t=", where $t = \Sigma + k$. Switches S1:5 to S1:7 are used for the main adjustment, $\Sigma = 0 - 7$ s, and potentiometer P2 is used for the fine adjustment $k = 0,05 - 1,1$ s. The minimum time delay is 50 ms and the maximum time delay is 8,1 s.

When selecting this characteristic, the position of switch S1:8 ("RI" or "LI") has no influence.

Inverse-time delay.

Set switch S1:4 in position "Inv". The inverse-time characteristic is selected with the switches S1:5 to S1:8 (NI = Normal Inverse, VI = Very Inverse, EI = Extremely Inverse, RI = ASEA RI-relay inverse, LI = Long-time Inverse).

By setting the selector switch S1 a precedence order is applied, from top (S1:5) to bottom (S1:8). That is, if the "NI" characteristic is selected (the switch in the left hand side position), it overrides the settings of switches S1:6 to S1:8. Another example; if the "LI" characteristic shall be used, the switches S1:5 to S1:8 must all be in the right hand side position.

After setting the time characteristic, the time-delay is determined by the time factor k, which is adjusted with potentiometer P2 and the magnitude of the current.

4. Setting of the characteristic angle

The characteristic angle, α , is settable between -12° to $+12^\circ$, or -120° to $+120^\circ$.

Set the programming switch S1:10 for determining $-\alpha$ or $+\alpha$. Set the programming switch S1:9 to " $0,1 \times \alpha$ " for the characteristic angle $0^\circ - 12^\circ$, or " $1 \times \alpha$ " for the characteristic angle $0^\circ - 120^\circ$. The angle is adjusted with potentiometer P3.

5. Setting of the non-directional stage $I_{>>}$ operate value.

The operate value is set with potentiometer P4 according to $I_{>>} = P4 \times I_s$.

This function can be blocked by setting potentiometer P4 to " ∞ ".

6. The binary input.

There are two binary inputs on the relay. Input 1 (terminals 111/112-113) is used for external blocking of the directional low-set delayed stage. The directional low-set start and non-directional high-set stage will be unaffected. Input 2 (terminals 121/122-123) is used for remote reset of the LED indicators. The functions are activated when a voltage RL is applied to the binary inputs.

INDICATION

There are four LED indicators. The trip indicators seal-in and are reset manually by the "Reset" push-button or electrically via the binary input, while the start indicator resets automatically when the relay resets.

When the "Reset" push-button is depressed during normal operating conditions, all LEDs except "In serv." will light up.

When connecting RXPDK 21H to the auxiliary voltage, the relay performs a self test. The "In serv." LED is alight, after performing the self test and when the relay is ready for operation. In case of a fault, the LEDs will start flashing.

TRIPPING AND START OUTPUTS

The RXPDK 21H relay has one start and one delayed tripping output for the directional stage, and one tripping output for the non-directional stage. Each output is provided with one change-over contact. All outputs reset automatically when the current decreases to a value below the resetting value of the relay.

ESD

The relay contains electronic circuits which can be damaged if exposed to static electricity. Always avoid to touch the circuit board when the relay cover is removed.

RXPDK 22H

Rated current of the relay, I_r (available variants: 0,05A or 0,2A)

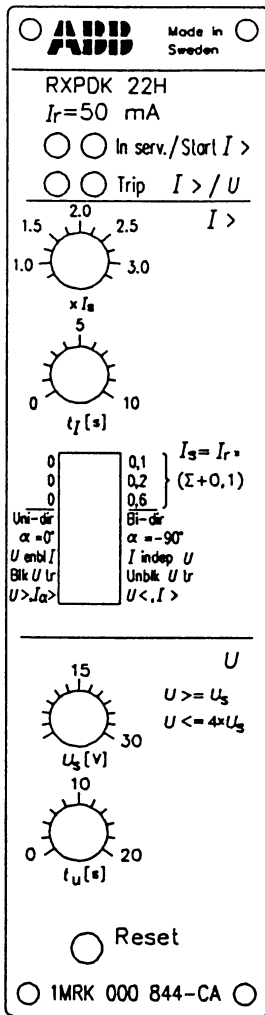

1MRK 000 117-92

Fig. 25 Front layout

LED indicators:

In serv. (green): indicates relay in service.

Start I>(yellow): indicates operation of I> (no time delay).

Trip I> (red): indicates operation of I> after the set time delay.

Trip U (red): indicates operation of U after the set time delay.

I> (Directional/non-directional over-current):

Potentiometer (P1) for setting of the operate value for the function I>.

Potentiometer (P2) for setting of the definite time delay t_I for the function I>.

8-pole programming switch (S1) for setting of the scale constant I_s , uni-directional or bi-directional operation, characteristic angle α , function I> dependent or independent of U set value, blocking or unblocking of U trip, and directional or non-directional operation.

U (Over/Under voltage):

Potentiometer (P3) for setting of the operate value U_s for the function U.

Potentiometer (P4) for setting of the definite-time delay t_u for the function U.

Reset push-button.

CONNECTION:

The RXPDK 22H relay requires a dc-dc converter type RXTUG for auxiliary voltage supply ± 24 V. Connection of the voltage RL shall be made only when the binary input is used.

The relay is delivered with a short-circuiting connector RTXK for mounting on the rear of the terminal base. This connector will automatically short-circuit the current input when the relay is removed from its terminal base.

NOTE! The auxiliary voltage supply should be interrupted or the output circuits should be blocked to avoid the risk of unwanted alarm or tripping, before the relay is plugged into or withdrawn from its terminal base.

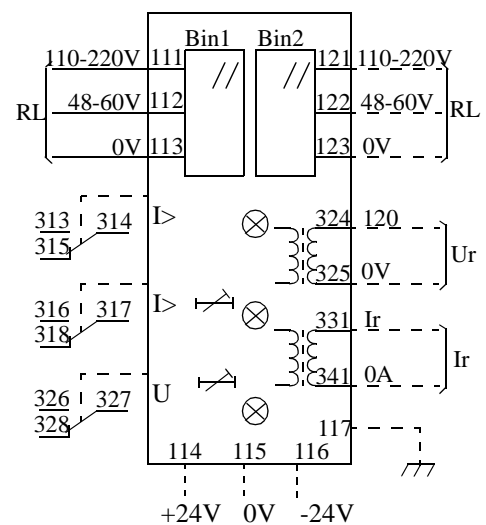

Fig. 26 Terminal diagram RXPDK 22H

SETTINGS:

All settings can be changed while the relay is in normal service.

1. Setting of the scale-constant I_s .

The scale constant I_s is equal to the rated current I_r times the sum of the set value of the switches S1:1, S1:2 and S1:3 plus 0,1. The setting range is from 0,1 to $1,0 \times$ the rated current I_r .

2 Setting of the overcurrent stage (directional, $I_{\alpha>}$ or non-directional, $I_{>}$) operate value.

The operate value is set with potentiometer P1 according to $I_{>} = P1 \times I_s$. The setting range is $0,75-3,25 \times I_s$.

The directional function operates for $I \times \cos(\varphi - \alpha) \geq \text{set } I_{\alpha>}$ where φ is the phase angle between U and I.

3. Setting of the time delay t_1 of the overcurrent stage $I_{>}$.

The time delay for stage $I_{>}$ has definite-time characteristic. The setting range is 0 - 10 s. The setting is done with potentiometer P2.

4. Setting of the different modes of operation.

The RXPDK 22H relay can be programmed for different modes of operation, with a directional or non-directional over-current stage, and a voltage stage to be used for enabling the over-current stage and as a neutral point voltage protection. The settings are done with the programming switches S1:4 to S1:8.

4.1. Setting of directional overcurrent, $I_{\alpha>}$ and overvoltage, U> functions.

Set the switch S1:8 in position "U>, $I_{\alpha>}$ " for directional function of stage $I_{>}$ and for overvoltage function of stage U. The directional over-current function is enabled or independent of the voltage U according to 4.1.2 or 4.1.3 below.

4.1.1 Setting of Uni-directional or Bi-directional operation and the characteristic angle α .

The Uni-directional or Bi-directional operation of stage $I_{\alpha>}$ is set with the switch S1:4, "Uni-dir" and "Bi-dir" respectively. The characteristic angle is set to " $\alpha=0^\circ$ " or " $\alpha=-90^\circ$ ", with the switch S1:5. When the characteristic angle is set to 0° and the switch S1:4 is set to position "Uni.dir", the relay operates for a resistive earth current in one direction towards a fault point, and with the switch S1:4 in position "Bi.dir" the relay operates in both directions, i.e. α is 0° and 180° . When the characteristic angle is set to -90° the relay operates for a capacitive earth fault current in one direction independent of the setting of switch S1:4.

4.1.2 Setting of U to enable $I_{\alpha>}$ and function U>.

Set the switch S1:6 in position "U enbl I". The $I_{\alpha>}$ function is enabled when voltage U exceeds the set value of U>. U> is equal to U_s set on potentiometer P3, the setting range is 5 - 30 V.

Set the switch S1:7 to "Blk U tr" for blocking of, or "Unblk U tr" for unblocking of the U> tripping (indication and output contact).

4.1.3 Setting of $I_{\alpha>}$ to be independent of U and function U>.

Set the switch S1:6 in position "I indep U". The $I_{\alpha>}$ function is enabled if $U \geq 5$ V.

The function U> is set on potentiometer P3. The setting range is 5 - 30 V.

Set the switch S1:7 to "Blk U tr" for blocking of, or "Unblk U tr" for unblocking of the U> tripping (indication and output contact).

4.2. Setting of non-directional overcurrent, $I_{>}$ and undervoltage, U< functions:

Set the switch S1:8 in position "U<, $I_{>}$ " for non-directional function of stage $I_{>}$ and for undervoltage function of stage U. The non-directional over-current function is enabled or independent of the voltage U according to 4.2.1 or 4.2.2 below. The settings of switches S1:4 and S1:5 have no effect on this function.

4.2.1 Setting of U to enable $I_{>}$ and function U<.

Set the switch S1:6 in position "U enbl I". The $I_{>}$ function is enabled when the voltage U falls below the set value of U<. U< is equal to 4 times the value U_s set on potentiometer P3. The setting range is 5 - 120 V.

Set the switch S1:7 to "Blk U tr" for blocking of, or "Unblk U tr" for unblocking of the U< tripping (indication and output contact).

4.2.2 Setting of I to be independent of U and function U<.

Set the switch S1:6 in position "I indep U". The $I_{>}$ function operates independent of the voltage U and the setting of U<.

The function U< = $4 \times U_s$ is set on potentiometer P3. The setting range is 5 - 120 V.

Set the switch S1:7 to "Blk U tr" for blocking of, or "Unblk U tr" for unblocking of the U< tripping (indication and output contact).

5. Setting of the time delay t_u of the voltage stage U.

The time delay for stage U has definite-time characteristic. The setting range is 0 - 20 s. The setting is done with potentiometer P4.

6. The binary input.

There are two binary inputs (Bin 1 and Bin 2) on the relay. Bin 1 (terminals 111/112-113) is used for changing the characteristic angle from 0° to -90° or -90° to 0° . Bin 2 (terminals 121/122-123) is used for resetting of the LED indicators. The functions are activated when a voltage RL is applied to the binary inputs.

INDICATION

There are four LED indicators. The trip indicators seal-in and are reset manually by the "Reset" push-button or electrically via the binary input Bin 2. The start indicator resets automatically when the relay resets. When the "Reset" push-button is depressed during normal operating conditions, all LEDs except "In serv." will light up. When connecting RXPDK 22H to the auxiliary voltage, the relay performs a self test. The "In serv." LED is alight, after performing the self test and when the relay is ready for operation. In case of a fault, the LEDs will start flashing.

TRIPPING AND START OUTPUTS

The RXPDK 22H relay has one start and one tripping output for the overcurrent stage, and one tripping output for the voltage stage. Each output is provided with one change-over contact. All outputs reset automatically when the energising quantity passes the resetting value of the relay.

ESD

The relay contains electronic circuits which can be damaged if exposed to static electricity. Always avoid to touch the circuit board when the relay cover is removed.

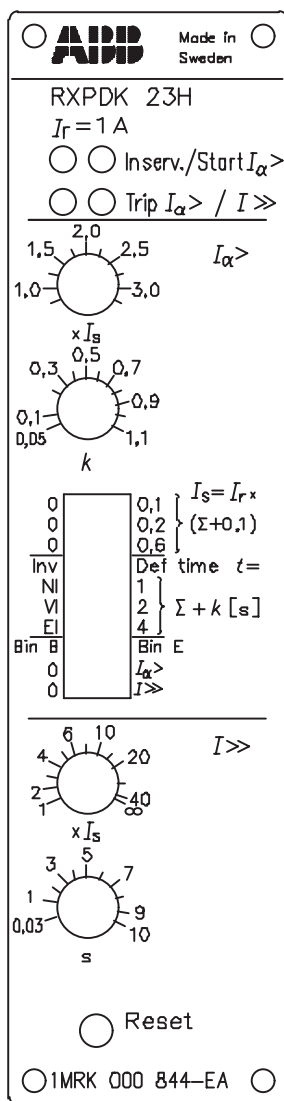

1MRK 000 117-52

Fig. 27 Front layout

INSTALLATION

The RXPDK 23H relay requires a dc-dc converter type RXTUG for auxiliary supply ± 24 V. Connection of voltage RL shall be made only when the binary input is used.

The relay is delivered with a short-circuiting connector RTXK for mounting on the rear of the terminal base. This connector will automatically short-circuit the current input when the relay is removed from its terminal base.

NOTE! The auxiliary voltage supply should be interrupted or the output circuits should be blocked to avoid the risk of unwanted alarm or tripping, before the relay is plugged into or withdrawn from its terminal base.

RXPDK 23H

Rated voltage of the relay $U_r = 120$ V.
Rated current of the relay, $I_r = 1$ A or 5 A.
Rated frequency of the relay $f_r = 50$ Hz and 60 Hz.

LED indicators:

In serv. (green): indicates relay in service.
Start $I_{\alpha>}$ (yellow): indicates operation of $I_{\alpha>}$ (no time delay).
Trip $I_{\alpha>}$ (red): indicates operation of $I_{\alpha>}$ after the set t time delay.
Trip $I_{>>}$ (red): indicates operation of $I_{>>}$ after the set s time delay.

$I_{\alpha>}$ Directional over-current stage:

Potentiometer (P1) for setting of the operate value for the function.
Operates when $I \geq \text{set } I_{\alpha>}$ and $140^\circ \geq \varphi \geq 0^\circ$.

Potentiometer (P2) for setting of the inverse time factor or definite-time delay.

10-pole programming switch (S1) for setting of the scale constant I_s , inverse or definite-time delay, time delay characteristic and binary input function.

$I_{>>}$ non-directional high set stage:

Potentiometer (P3) for setting of the operate value for the function.
Operates when $I \geq \text{set } I_{>>}$

Potentiometer (P4) for setting of the definite-time delay for the function $I_{>>}$.

Reset push-button.

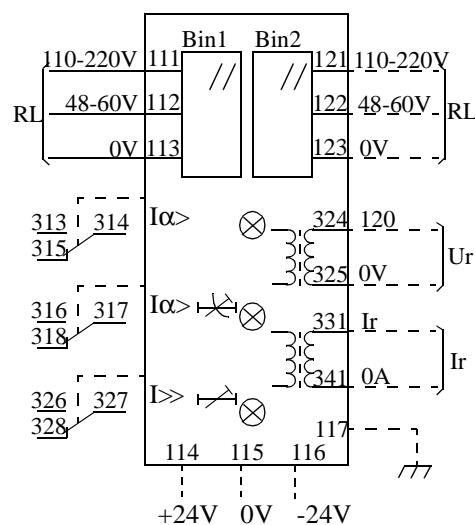

Fig. 28 Terminal diagram RXPDK 23H

SETTINGS:

All settings can be changed while the relay is in normal service.

1. Setting of the scale-constant I_s .

I_s is set with the programming switches S1:1, S1:2 and S1:3. Available settings are 0,1, 0,4, 0,7 and 1,0 x rated current I_r .

2. Setting of the operate value for the directional over-current stage $I_{\alpha>}$.

The operate value $I_{\alpha>}$ is set with potentiometer P1 according to $P1 \times I_s$.

3. The directional over-current stage time delay.

The directional stage has four characteristics, which are programmed on the programming switches S1:4 to S1:7

Definite-time delay.

Set switch S1:4 to position Def. time, where $t = \Sigma + k$. Switches S1:5 to S1:7 are used for the main adjustment within the range $\Sigma = 0 - 7$ s. The potentiometer P2 is used for the fine adjustment, $k = 0,05 - 1,1$ s. The minimum time delay is 50 ms and the maximum time delay is 8,1 s.

Inverse-time delay.

Set switch S1:4 to position Inv., the inverse-time delay characteristic is selected with the switches S1:5 to S1:7 (NI = Normal Inverse, VI = Very Inverse and EI = Extremely Inverse). By setting the selector switch S1 a precedence order is applied, from top (S1:5) to bottom (S1:7). That is, if the NI characteristic is selected, it overrides the settings of switch S1:6 and S1:7.

After setting the inverse-time characteristic, the time delay is determined by the inverse-time factor k, which is adjusted with potentiometer P2.

4. Setting of the high set stage $I_{>>}$ operate current.

The operate value $I_{>>}$ is set with potentiometer P3 according to $P3 \times I_s$.

This function can be blocked by setting potentiometer to ∞ .

5. The non-directional high set stage time delay.

The time delay for the high set stage ($I_{>>}$) has definite-time characteristic. The minimum time delay is 30 ms and the maximum time delay is 10 s. The setting is done with potentiometer P4.

6. The binary inputs.

There are two binary inputs, the Bin1 and Bin2.

Blocking or enabling of the trip functions.

The first binary input (Bin1) is used for blocking or enabling of the trip functions. By setting the switch S1:8 to Bin B, active signal on the Bin 1 input will block selected function settled with switch S1:9 and S1:10. By setting the switch S1:8 to Bin E active signal on the Bin1 input will enabling selected function. When S1:9 is set to 0, the binary input Bin1 will not influence the function. When S1:10 is set to 0, the binary input Bin 1 will not influence the function.

Remote resetting of the LED indicators.

The second binary input Bin2 is used for remote reset of the Trip $I_{\alpha>}$ and Trip $I_{>>}$ LED indicators.

The function is activated when a voltage is applied to input Bin2.

INDICATION

There are four LED indicators. The trip indicators seal-in and are reset manually by the "Reset" push-button, while the start indicator resets automatically when the relay resets. When the "Reset" push-button is depressed during normal operating conditions, all LED's except "In serv." will light up.

When connecting RXPDK 23H to the supply voltage, the relay performs a self test. The "In serv." LED is alight, after performing the self test and when the relay is ready for operation. In case of a fault, the LED's will start flashing.

Tripping and start outputs. The RXPDK 23H relay has one start and two tripping outputs. Each output is provided with one change-over contact.

All outputs reset automatically when the measured value decreases below the resetting value of the relay.

ESD

The relay contains electronic circuits which can be damaged if exposed to static electricity.

Always avoid to touch the circuit board when the relay cover is removed during the setting procedure

5 Technical data

5.1 Time-overcurrent relay RXIDK 2H

Current input

Rated current I_r	0,2 A or 1 A or 5 A
Scale constant I_s	(0,1 0,2 0,4 1,0) x I_r
Setting ranges	
0,2 A Variant I > I >>	15-650 mA 0,02-8 A
1 A Variant I > I >>	0,075-3,25 A 0,1-40 A
5 A Variant I > I >>	0,375-16,25 A 0,5-200 A
Effective current range	(0,75-65) x I_s
Rated frequency f_r	50-60 Hz
Frequency characteristics	Filter options: 50-60 Hz, flat, (standard variant) see figure 29. 50-60 Hz, sharp see figure 30. 150-180 Hz, sharp see figure 31. 40-2000 Hz, flat see figure 32.
Frequency range	40-2000 Hz
Power consumption	
0,2 A variant I = I_s = 20 mA I = I_s = 200 mA	0,03 mVA 1,2 mVA
1 A variant I = I_s = 0,1 A I = I_s = 1 A	0,5 mVA 50 mVA
5 A variant I = I_s = 0,5 A I = I_s = 5 A	1 mVA 100 mVA
Overload capacity for	
0,2 A variant I_s = 20/40/80/200 mA continuously	2/4/4/4 A
1 A variant continuously	6 A
5 A variant continuously	20 A
0,2 A variant during 1 s	20 A
1 A variant during 1 s	100 A
5 A variant during 1 s	350 A

Current functions, standard variant

Current function	Low set stage I>	High set stage I>>
Setting range	$(0,75-3,25) \times I_s$	$(1-40) \times I_s$ and ∞
Operate time, typical $I = 0 = > 1,3 \times I >$ $I = 0 = > 3 \times I >$ $I = 0 = > 10 \times I >$	35 ms 25 ms 20 ms	
Reset time, typical $I = 1,3 = > 0 \times I >$ $I = 3 = > 0 \times I >$ $I = 10 = > 0 \times I >$	25 ms 35 ms 45 ms	
Consistency of operate value	< 0,5%	
Reset ratio (typical)	95%	
Consistency	< 1,5%	
"Cold load" activated	Operate value increases 40%	N.A
Transient over-reach L/R=10, 50 and 100 ms	< 5%	
Overshoot time	< 20 ms	
Recovery time at $I = 3 \times I >$	< 40 ms	
Frequency dependence within frequency range 47,5 - 63,0 Hz	< 2,5%	
Operate value at 150 Hz	App. 1,5 x set op. value	
Influence of harmonics 100 / 120 Hz, 10% 150 / 180 Hz, 20% 250 / 300 Hz, 20%	< 3% < 6% < 4%	
Temperature dependence within range -5°C to +55°C	< 2%	

Time Function

Time function	Low set stage I>	High set stage I>>
Time delay	Inverse and definite time (Normal, Very, Extremely, Long time and RI inverse time)	Definite time
Setting range Definite time Inverse time	0,05-8,1 s $k = 0,05-1,1$	0,03-1,0 s -
Accuracy Definite time Inverse time	1% and ± 10 ms NI, VI, EI and LI 2 x op. value 12,5% and ± 30 ms NI, VI, EI and LI 5 x op. value 7,5% and ± 30 ms NI, VI, EI and LI 10 x op. value 5% and ± 30 ms NI, VI, EI and LI 20 x op. value 5% and ± 30 ms RI 1,0 x op. value 12,5% and ± 30 ms 1,3 x op. value 12,5% and ± 30 ms 1,5 x op. value 5% and ± 30 ms 10 x op. value 5% and ± 30 ms 20 x op. value 5% and ± 30 ms	1% and ± 10 ms
Consistency	< 0,5%	< 0,5%

Filter options, deviation from technical data for RXIDK 2H, standard variant

	Filter options		
	50-60 Hz, sharp	150-180 Hz, sharp	40-2000 Hz, flat
Operate time (typical) I = 0 = > 1,3 x op. value I = 0 = > 2 x op. value I = 0 = > 10 x op. value	65 ms 55 ms 35 ms	45 ms 35 ms 25 ms	35 ms 25 ms 20 ms
Reset time (typical) I = 1,3 = > 0 x op. value I = 2 = > 0 x op. value I = 10 = > 0 x op. value	40 ms 50 ms 100 ms	30 ms 35 ms 55 ms	20 ms 25 ms 50 ms
Reset ratio (typical)	95%		
Recovery time at I = 3 x op. value	< 65 ms	< 45 ms	< 40 ms
Overshoot time	< 35 ms	< 25 ms	< 20 ms
Transient over-reach L/R = 10, 50 and 100 ms	< 2%	< 2%	< 20%
Frequency dependence within frequency range ±5%	< 12%	< 20%	–
Influence of harmonics			
50, 60 Hz, 100%	–	< 1%	–
100, 120 Hz, 100%	< 2%	< 4%	–
150, 180 Hz, 100%	< 2%	–	–
250, 300 Hz, 100%	< 2%	< 2%	–

See also technical data common for RXIDK 2H, RXIDG 21H

5.2 Time overcurrent relay RXIDK 2H, 16 Hz

Current input

Rated current I_r	1 A or 5 A
Scale constant I_s	(0,1 0,2 0,4 1,0) $\times I_r$
Setting ranges	
1 A Variant $I >$	0,075-3,25 A *) 0,075-3,25 A
$I >>$	0,1-40 A 0,075-40 A
5 A Variant $I >$	0,375-16,25 A *) 0,375-16,25 A
$I >>$	0,5-200 A 0,375-200 A
	*) Alternative version 16 2/3 Hz
Effective current range	(0,75-65) $\times I_s$
Rated frequency f_r	16 2/3 Hz
Frequency characteristic	See figure 33.
Frequency range	15-100 Hz
Power consumption	
1 A variant $I = I_s = 0,1$ A	0,5 mVA
$I = I_s = 1$ A	50 mVA
5 A variant $I = I_s = 0,5$ A	1 mVA
$I = I_s = 5$ A	100 mVA
Overload capacity	
1 A variant continuously	4 A
5 A variant continuously	20 A
1 A variant during 1 s	100 A
5 A variant during 1 s	350 A

Current functions

Current functions	Low set stage $I >$	High set stage $I >>$
Setting range	(0,75-3,25) $\times I_s$	(1-40) $\times I_s$ and ∞ *) (0,75-40) $\times I_s$ and ∞ *) Alternative version 16 2/3 Hz
Operate time, typical		
$I = 0 = > 1,3 \times I >$	80 ms	
$I = 0 = > 2 \times I >$	65 ms	
$I = 0 = > 10 \times I >$	45 ms	
Reset time, typical		
$I = 1,3 = > 0 \times I >$	55 ms	
$I = 3 = > 0 \times I >$	80 ms	
$I = 10 = > 0 \times I >$	100 ms	
Consistency of operate value	< 0,5%	
Reset ratio (typical)	95%	
Consistency	< 1,5%	
"Cold load" activated	Operate value increases 40%	N.A
Overshoot time	< 50 ms	
Recovery time at $I = 3 \times I >$	< 90 ms	
Frequency dependence within frequency range 15,00-18,33 Hz	< 2,0%	
Influence of harmonics:		
33 1/3 Hz, 5%	< 2%	
50 Hz, 20%	< 3%	
83 1/3 Hz, 20%	< 3%	

Time function

Time function	Low set stage I>	High set stage I>>																											
Time delay	Definite and inverse time (Normal, Very, Extremely, Long time and RI inverse time)	Definite time																											
Setting range																													
Definite time	0,05-8,1 s	0,06-1,0 s *) 0,06-5,0 s																											
Inverse time	k = 0,05-1,1	*) Alternative ver- sion 16 2/3 Hz																											
Accuracy																													
Definite time	1% and ±30 ms	1% and ±30 ms																											
Inverse time	<table border="0"> <tr> <td>NI, VI, EI and LI</td> <td>2 x op. value</td> <td>12,5% and ±60 ms</td> </tr> <tr> <td>NI, VI, EI and LI</td> <td>5 x op. value</td> <td>7,5% and ±60 ms</td> </tr> <tr> <td>NI, VI, EI and LI</td> <td>10 x op. value</td> <td>5% and ±60 ms</td> </tr> <tr> <td>NI, VI, EI and LI</td> <td>20 x op. value</td> <td>5% and ±60 ms</td> </tr> <tr> <td>RI</td> <td>1,0 x op. value</td> <td>12,5% and ±60 ms</td> </tr> <tr> <td></td> <td>1,3 x op. value</td> <td>12,5% and ±60 ms</td> </tr> <tr> <td></td> <td>1,5 x op. value</td> <td>5% and ±60 ms</td> </tr> <tr> <td></td> <td>10 x op. value</td> <td>5% and ±60 ms</td> </tr> <tr> <td></td> <td>20 x op. value</td> <td>5% and ±60 ms</td> </tr> </table>	NI, VI, EI and LI	2 x op. value	12,5% and ±60 ms	NI, VI, EI and LI	5 x op. value	7,5% and ±60 ms	NI, VI, EI and LI	10 x op. value	5% and ±60 ms	NI, VI, EI and LI	20 x op. value	5% and ±60 ms	RI	1,0 x op. value	12,5% and ±60 ms		1,3 x op. value	12,5% and ±60 ms		1,5 x op. value	5% and ±60 ms		10 x op. value	5% and ±60 ms		20 x op. value	5% and ±60 ms	–
NI, VI, EI and LI	2 x op. value	12,5% and ±60 ms																											
NI, VI, EI and LI	5 x op. value	7,5% and ±60 ms																											
NI, VI, EI and LI	10 x op. value	5% and ±60 ms																											
NI, VI, EI and LI	20 x op. value	5% and ±60 ms																											
RI	1,0 x op. value	12,5% and ±60 ms																											
	1,3 x op. value	12,5% and ±60 ms																											
	1,5 x op. value	5% and ±60 ms																											
	10 x op. value	5% and ±60 ms																											
	20 x op. value	5% and ±60 ms																											
Consistency	< 0,5%	< 0,5%																											

See also technical data common for RXIDK 2H, RXIDG 21H

5.3 Time-overcurrent relay RXIDG 21H

Current input

Rated current I_r	0,2 A
Scale constant I_s	20, 40, 80 and 200 mA
Scale rang I_a $I >$	15-650 mA 15mA-2,60 A
Effective current range	$(0,75-100) \times I_s$
Rated frequency f_r Frequency characteristic Frequency range	50-60 Hz See figure 34. 40-1000 Hz
Power consumption $I = I_s = 20$ mA $I = I_s = 40$ mA $I = I_s = 80$ mA $I = I_s = 200$ mA	0,03 mVA 0,1 mVA 0,3 mVA 1,2 mVA
Overload capacity at $I_s = 20/40/80/200$ mA - continuously - during 1 s	2/4/4/4 A 20/40/80/80 A

Start function

Operate value, $I >$	$K \times I_a$
Constant K	1-4
Basic current setting I_a	$(0,75-3,25) \times I_s$
Operate time, typical $I = 0 = > 1,3 \times I >$ $I = 0 = > 3 \times I >$ $I = 0 = > 20 \times I >$	35 ms 25 ms 20 ms
Reset time, typical $I = 1,3 = > 0 \times I >$ $I = 3 = > 0 \times I >$ $I = 20 = > 0 \times I >$	25 ms 35 ms 55 ms
Consistency of operate value	< 0,5%
Reset ratio (typical) Consistency	95% < 1,5%
Transient over-reach L/R = 10, 50 and 100 ms	< 5%
Overshoot time	< 20 ms
Recovery time at $I = 3 \times I >$	< 40 ms
Frequency dependence within frequency range 50 Hz, $\pm 5\%$ frequency range 60 Hz, $\pm 5\%$	< 0,5% < 1,0%
Operate value at 150 Hz	Approx. 1,5 x set op. value
Influence of harmonics 100 / 120 Hz, 10% 150 / 180 Hz, 20% 250 / 300 Hz, 20%	< 3% < 6% < 4%
Temperature dependence within range -5°C to +55°C	< 2%

Time function

Time delay	Inverse time and definite time
Operate time for inverse time, Inv Accuracy	Formula: $= 5,8 - 1,35 \times \ln I/I_a$, at $t > t_0$, see figure 35. Overall: ± 100 ms
Setting range for definite time, Def. time Accuracy	$t_0 = 1,0-2,0$ s Overall: ± 50 ms

See also technical data common for RXIDK 2H, RXIDG 21H

5.4 Technical data common for RXIDK 2H and RXIDG 21H

Auxiliary DC voltage supply

Measuring relays	RXIDK 2H		RXIDG 21H
	Standard	Other filters	
Auxiliary voltage EL for RXTUG 22H Auxiliary voltage to the relay	24-250 V DC, $\pm 20\%$ ± 24 V (from RXTUG 22H)		
Power consumption 24-250 V, before operation after operation without RXTUG 22H	Max. 4,5 W Max. 6,0 W	Max. 5,5 W Max. 6,5 W	Max. 4,5 W Max. 6,0 W
± 24 V, before operation after operation	Max. 1,3 W Max. 3,0 W	Max. 2,0 W Max. 3,0 W	Max. 1,3 W Max. 3,0 W

Binary inputs

Binary input voltage RL	48-60 V and 110-220 V DC, -20% to +10%
Power consumption 48-60 V 110-220 V	Max. 0,3 W Max. 1,5 W

Output relays

Contacts	3 change-over
Maximum system voltage	250 V AC / DC.
Current carrying capacity - continuous - during 1 s	5 A 15 A
Making capacity at inductive load with L/R >10 ms - during 200 ms - during 1 s	30 A 10 A
Breaking capacity - AC, max. 250 V, $\cos \varphi > 0,4$ - DC, with L/R < 40 ms, 48 V 110 V 220 V 250 V	8 A 1 A 0,4 A 0,2 A 0,15 A

Electromagnetic disturbance tests

All tests are done together with the DC/DC-converter, RXTUG 22H

Test	Severity	Standard
Surge immunity test	1 and 2 kV, normal service 2 and 4 kV, destructive test	IEC 61000-4-5, class 3 IEC 61000-4-5, class 4
AC injection test	500 V, AC	SS 436 15 03, PL 4
Power frequency field immunity test	1000 A/m	IEC 61000-4-8
1 MHz burst test	2,5 kV	IEC 60255-22-1, class 3
Spark test	4-8 kV	SS 436 15 03, PL 4
Fast transient test	4 kV	IEC 60255-22-4, class 4
Electrostatic discharge test - In normal service with cover on	8 kV (contact) 15 kV (air) 8 kV, indirect application	IEC 60255-22-2, class 4 IEC 60255-22-2, class 4 IEC 61000-4-2, class 4
Radiated electromagnetic field test	10 V/m, 26-1000 MHz	IEC 61000-4-3, Level 3
Conducted electromagnetic test	10 V, 0,15-80 MHz	IEC 61000-4-6, Level 3
Interruptions in auxiliary voltage 110 VDC, no resetting for interruptions	2-200 ms < 40 ms	IEC 60255-11

Electromagnetic emission tests

Test	Severity	Standard
Conducted	0,15-30 MHz, class A	EN 50081- 2
Radiated emission	30-1000 MHz, class A	EN 50081- 2

Insulation tests

Test	Severity	Standard
Dielectric test - current circuit - other circuits - over open contact	2,5 kV AC, 1 min 2,0 kV AC, 1 min 1,0 kV AC, 1 min	IEC 60255-5
Impulse voltage test	5 kV, 1,2/50 μ s, 0,5 J	IEC 60255-5
Insulation resistance	> 100 M Ω at 500 V DC	IEC 60255-5

Mechanical tests

Test	Severity	Standard
Vibration	Response: 2,0 g, 10-150-10 Hz Endurance: 1,0 g, 10-150-10 Hz, 20 sweeps	IEC 60255-21-1, class 2 IEC 60255-21-1, class 1
Shock	Response: 5 g, 11 ms, 3 pulses Withstand: 15 g, 11 ms, 3 pulses	IEC 60255-21-2, class 1
Bump	Withstand: 10 g, 16 ms, 1000 pulses	IEC 60255-21-2, class 1
Seismic	X axis: 3,0 g, 1-35-1 Hz Y axis: 3,0 g, 1-35-1 Hz Z axis: 2,0 g, 1-35-1 Hz	IEC 60255-21-3, class 2, extended (Method A)

Temperature range

Storage	-20 °C to +70 °C
Permitted ambient temperature	-5 °C to +55 °C

Weight and dimensions

Equipment	Weight	Height	Width
RXIDK 2H without RXTUG 22H	0,7 kg	4U	6C
RXIDG 21H without RXTUG 22H	0,7 kg	4U	6C

Operate current / set operate current

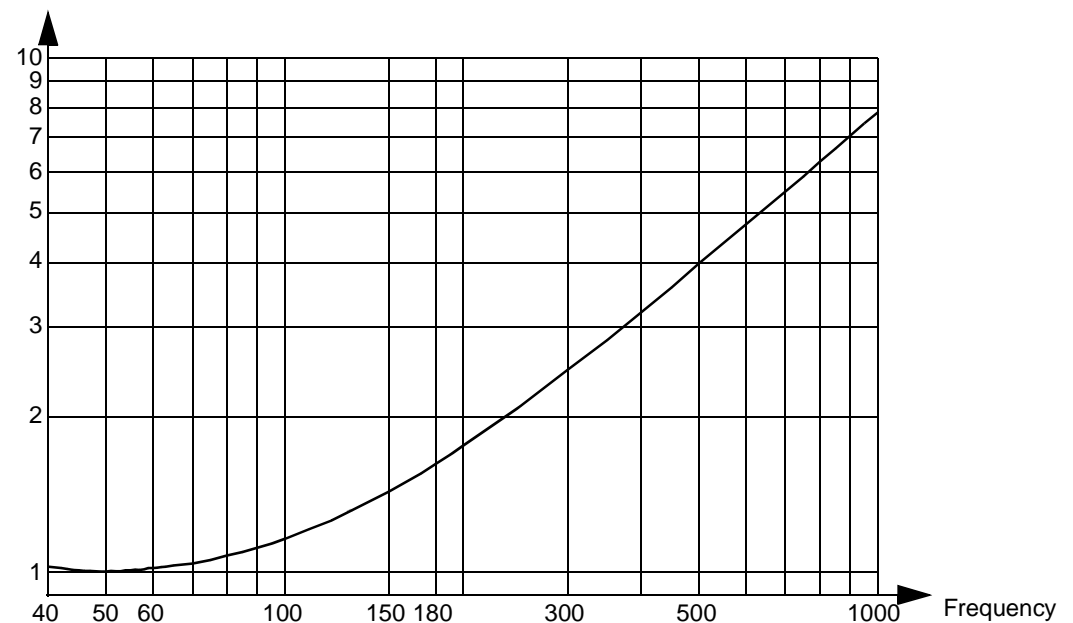

Fig. 29 Typical frequency characteristic for RXIDK 50-60 Hz, standard, valid for $I \leq 65 \times I_s$

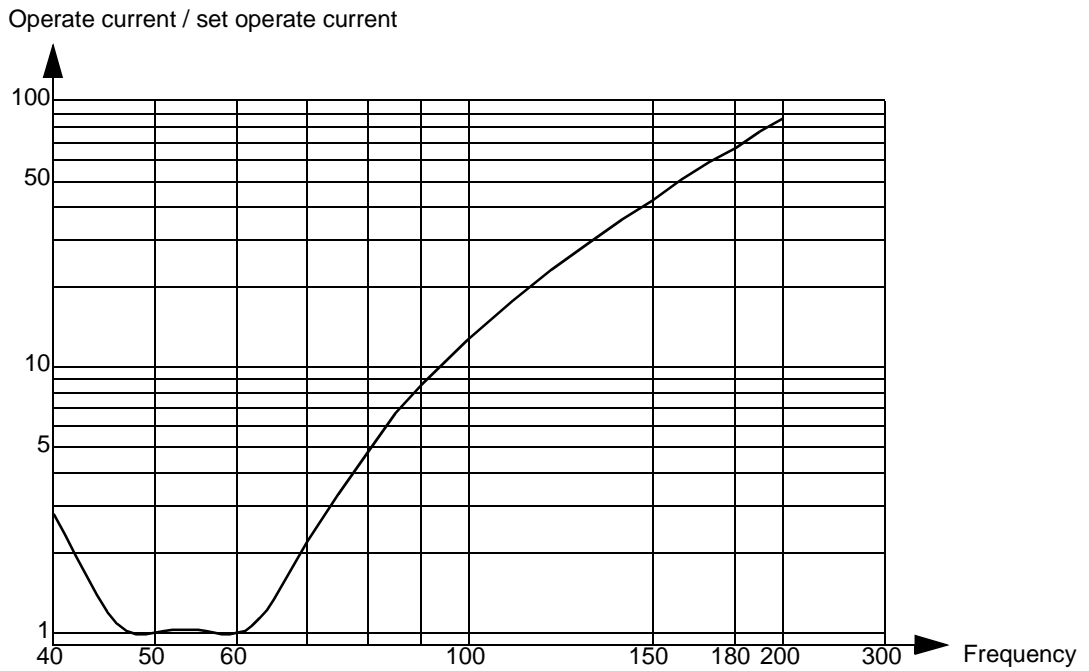

Fig. 30 Typical frequency characteristic for RXIDK 50-60 Hz, sharp, valid for $I \leq 65 \times I_s$

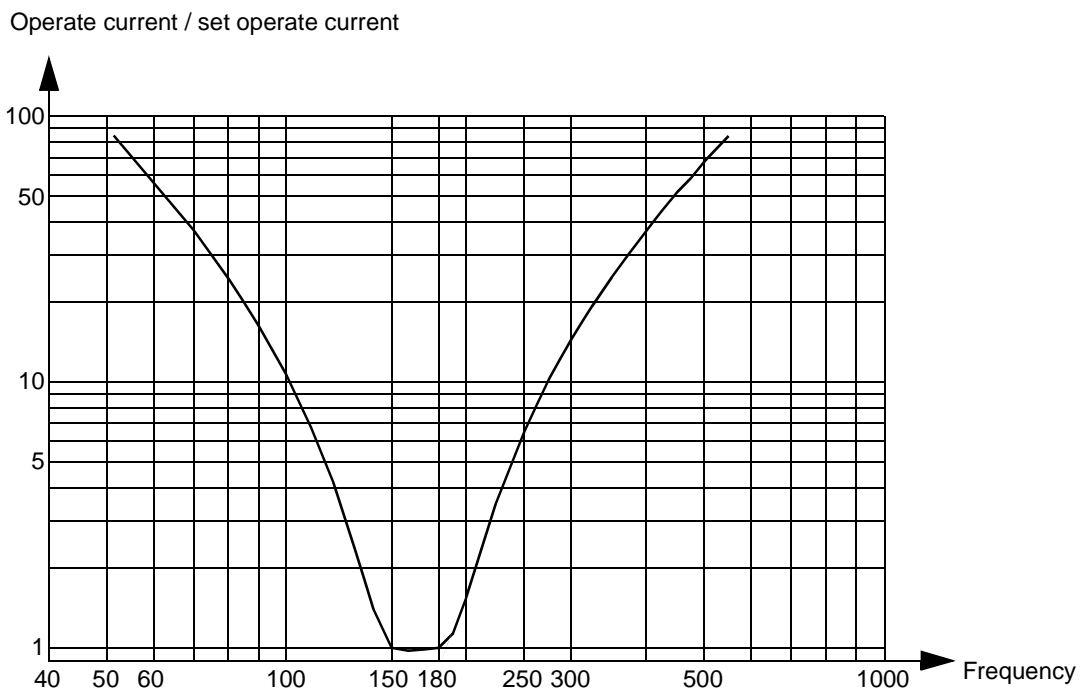

Fig. 31 Typical frequency characteristic for RXIDK 150-180 Hz, sharp, valid for $I \leq 65 \times I_s$

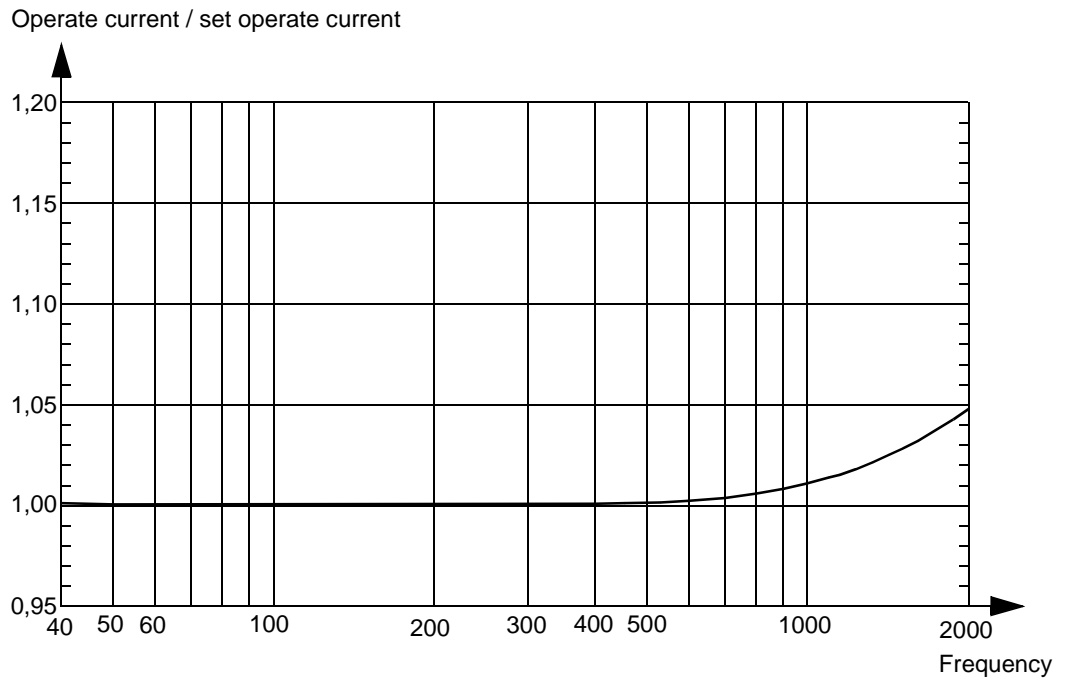

Fig. 32 Typical frequency characteristic for RXIDK 40-2000 Hz, valid for $I \leq 65 \times I_s$

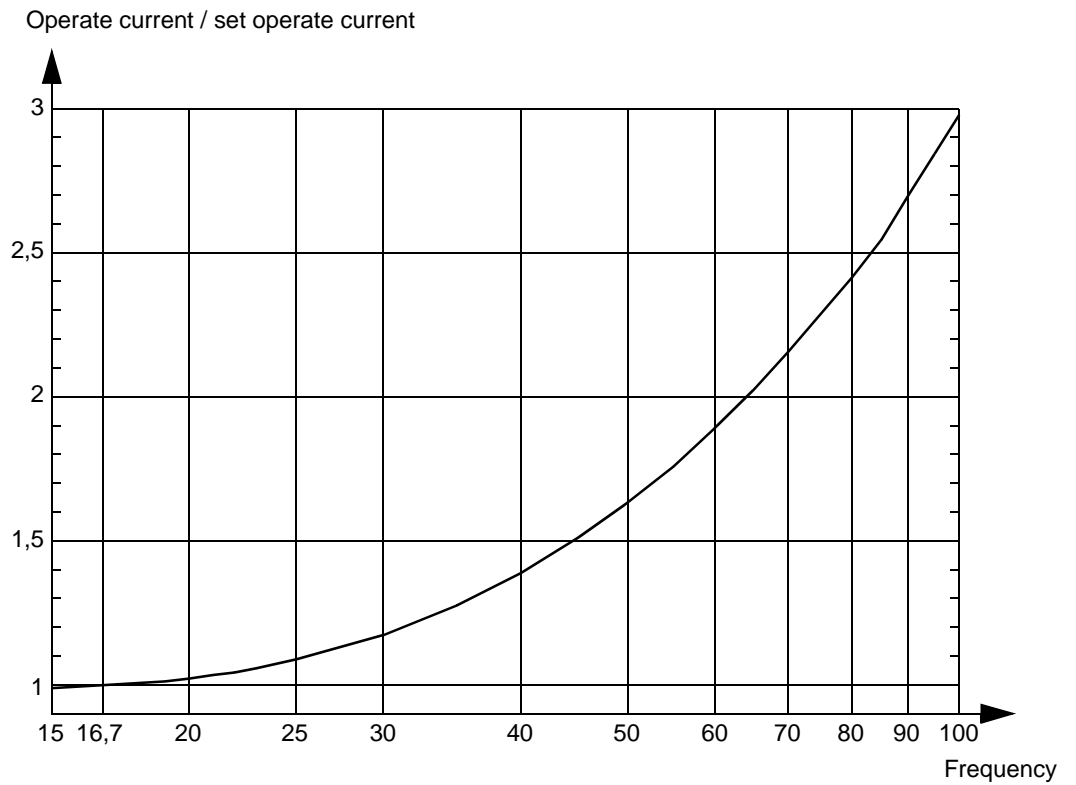
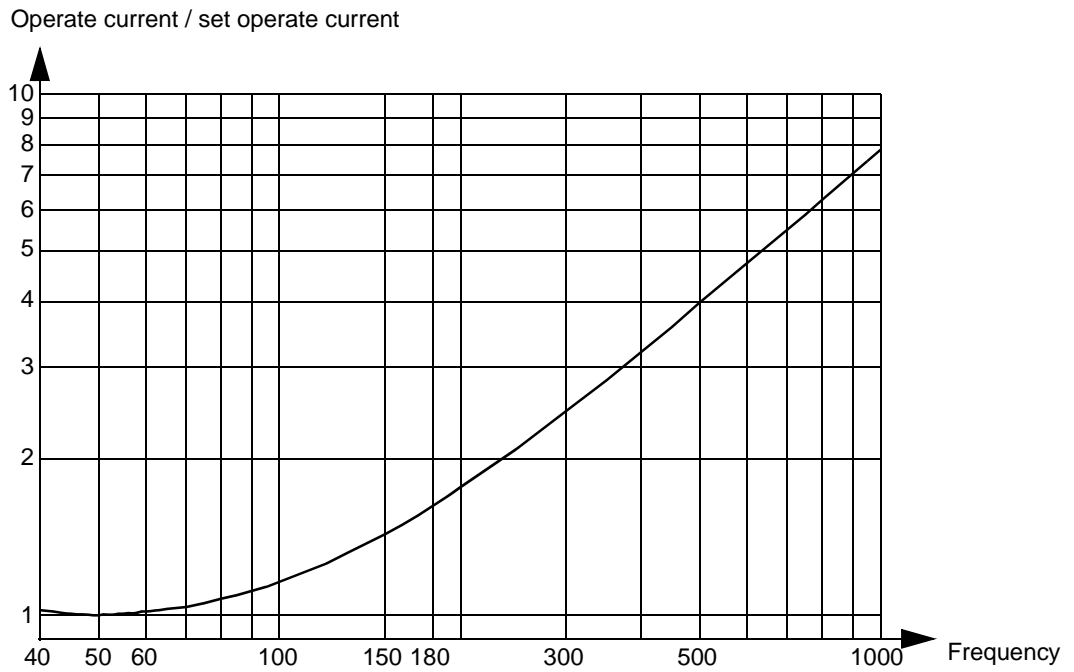

Fig. 33 Typical frequency characteristic for RXIDK 16 2/3 Hz, valid for $I \leq 65 \times I_s$



*Fig. 34 Typical frequency characteristic for RXIDG 50-60 Hz, valid
for valid for $I \leq 100 \times I_s$*

5.5 Directional time- overcurrent relay RXPDK 21H

Voltage and current inputs

Rated voltage U_r	120 V
Rated current I_r	1 A or 5 A
Scale constant I_s	(0,1 0,2 0,4 and 1,0) x I_r
Scale range	
1 A Variant	$I_{\alpha} >$ $I >>$ 0,075-3,25 A 0,1-40 A
5 A Variant	$I_{\alpha} >$ $I >>$ 0,375-16,25 A 0,5-200 A
Effective voltage range U	5-200 V
Effective current range	(0,75-65) x I_s
Rated frequency f_r	50-60 Hz
Operating frequency range	45-66 Hz
Power consumption for: U = U_r	
1 A variant	$I = I_s = 0,1$ A $I = I_s = 1$ A 0,25 VA 0,5 mVA 50 mVA
5 A variant	$I = I_s = 0,5$ A $I = I_s = 5$ A 1,5 mVA 100 mVA
Overload capacity voltage:	continuously during 10 s 250 V 300 V
Overload capacity current:	
1 A variant	continuously 4 A
5 A variant	continuously 20 A
1 A variant	during 1 s 100 A
5 A variant	during 1 s 350 A

Current functions

Current functions	Low set stage $I_{\alpha>}$	High set stage $I_{>>}$
Setting range	$(0,75-3,25) \times I_s$	$(1,0-40) \times I_s$ and ∞
Binary input 1 "block" Active signal on binary input 1, blocks the time delayed $I_{\alpha>}$	Directional function	–
Angle φ between U and I	Positive if I lags U	–
Setting range for characteristic angle α	-12° to $+12^\circ$ or -120° to $+120^\circ$ Alt. version only -120° to $+120^\circ$	–
Operate condition $I_{\alpha>}$	$I \times \cos(\varphi-\alpha) \geq \text{set } I_{\alpha>}$ See fig. 11	–
Voltage memory	When the input voltage U drops below 5 V the voltage memory is activated. The phase angle is freezed after 100 ms and resets when the start function resets. When U = 0 before the overcurrent start e.g. at switching on a line, the relay will operate as follows: - U < 5 V: non-directional operation - U > 5 V: non-directional operation during the first 200 ms and then directional operation	
Operate time at $\varphi = \alpha$, typical I = 0 => $3 \times I_{\alpha>}$ I = 0 => $10 \times I_{\alpha>}$	dir. at $\varphi = \alpha$ non directional alt. version 90 ms 40 ms 85 ms 30 ms	30 ms 20 ms
Reset time at $\varphi = \alpha$, typical I = 3 => $0 \times I_{\alpha>}$ I = 10 => $0 \times I_{\alpha>}$	40 ms 55 ms	
Consistency of the op. value	< 2% at $\varphi = \alpha$	< 2%
Accuracy for characteristic angle α : 0-40 $\times I_s$ 40-100 $\times I_s$	< 3° < 5°	–
Reset ratio (typical)	90%	
Transient over-reach L/R=10, 50 and 100 ms	< 5%	
Overshoot time	< 55 ms	< 20 ms
Recovery time at I = $3 \times I_{\alpha>}$	< 50 ms	
Frequency dependence 45-65 Hz	< $\pm 5\%$	
Influence of harmonics in:	Angle dependence	Current dependence
U 100 / 120 Hz, 20%	< 3°	–
150 / 180 Hz, 100%	< 5°	–
250 / 300 Hz, 100%	< 4°	–
I 100 / 120 Hz, 20%	< 4°	< 3%
150 / 180 Hz, 10%	< 6°	< 3%
150 / 180 Hz, 20%	< 10°	< 4%
250 / 300 Hz, 20%	< 7°	< 3%

Time function

Time function		Low set stage $I_{\alpha >}$																																															
Time delay		Inverse and definite time (Normal, Very, Extremely, Long time and RI inverse time)																																															
Setting range	Definite time Inverse time	0,05-8,1 s $k = 0,05-1,1$																																															
Accuracy	Definite time	The tolerances for inverse and definite time delay are calculated under the condition that the current before operation is higher than $0,4 \times I_s$, otherwise add 20-30 ms. 1% and ± 50 ms																																															
	Inverse time																																																
Consistency		<table border="0"> <tr> <td>NI, VI, EI and LI</td> <td>2</td> <td>x op. value</td> <td>12,5%</td> <td>and ± 30 ms</td> </tr> <tr> <td>NI, VI, EI and LI</td> <td>5</td> <td>x op. value</td> <td>7,5%</td> <td>and ± 30 ms</td> </tr> <tr> <td>NI, VI, EI and LI</td> <td>10</td> <td>x op. value</td> <td>5%</td> <td>and ± 30 ms</td> </tr> <tr> <td>NI, VI and LI</td> <td>20</td> <td>x op. value</td> <td>5%</td> <td>and ± 30 ms</td> </tr> <tr> <td>EI</td> <td>20</td> <td>x op. value</td> <td>5%</td> <td>and +80 -30 ms</td> </tr> <tr> <td rowspan="4">RI</td> <td>1,0</td> <td>x op. value</td> <td>12,5%</td> <td>and ± 30 ms</td> </tr> <tr> <td>1,3</td> <td>x op. value</td> <td>12,5%</td> <td>and ± 30 ms</td> </tr> <tr> <td>1,5</td> <td>x op. value</td> <td>5%</td> <td>and ± 30 ms</td> </tr> <tr> <td>10</td> <td>x op. value</td> <td>5%</td> <td>and ± 30 ms</td> </tr> <tr> <td></td> <td>20</td> <td>x op. value</td> <td>5%</td> <td>and ± 30 ms</td> </tr> </table>	NI, VI, EI and LI	2	x op. value	12,5%	and ± 30 ms	NI, VI, EI and LI	5	x op. value	7,5%	and ± 30 ms	NI, VI, EI and LI	10	x op. value	5%	and ± 30 ms	NI, VI and LI	20	x op. value	5%	and ± 30 ms	EI	20	x op. value	5%	and +80 -30 ms	RI	1,0	x op. value	12,5%	and ± 30 ms	1,3	x op. value	12,5%	and ± 30 ms	1,5	x op. value	5%	and ± 30 ms	10	x op. value	5%	and ± 30 ms		20	x op. value	5%	and ± 30 ms
	NI, VI, EI and LI	2	x op. value	12,5%	and ± 30 ms																																												
NI, VI, EI and LI	5	x op. value	7,5%	and ± 30 ms																																													
NI, VI, EI and LI	10	x op. value	5%	and ± 30 ms																																													
NI, VI and LI	20	x op. value	5%	and ± 30 ms																																													
EI	20	x op. value	5%	and +80 -30 ms																																													
RI	1,0	x op. value	12,5%	and ± 30 ms																																													
	1,3	x op. value	12,5%	and ± 30 ms																																													
	1,5	x op. value	5%	and ± 30 ms																																													
	10	x op. value	5%	and ± 30 ms																																													
	20	x op. value	5%	and ± 30 ms																																													
		< 0,5%																																															

See also technical data common for RXPDK 21H, RXPDK 22H and RXPDK 23H

5.6 Directional time-overcurrent relay RXPDK 22H

Voltage and current inputs

Rated voltage U_r	120 V															
Rated current I_r	50 mA or 200 mA															
Scale constant I_s	$(0,1 \ 0,2 \ 0,4 \ \text{and} \ 1,0) \times I_r$															
Scale range	<table border="0"> <tr> <td>50 mA Variant</td> <td>$I_{\alpha >}$</td> <td>3,75 - 160 mA</td> </tr> <tr> <td>200 mA Variant</td> <td>$I_{\alpha >}$</td> <td>15 - 650 mA</td> </tr> </table>	50 mA Variant	$I_{\alpha >}$	3,75 - 160 mA	200 mA Variant	$I_{\alpha >}$	15 - 650 mA									
50 mA Variant	$I_{\alpha >}$	3,75 - 160 mA														
200 mA Variant	$I_{\alpha >}$	15 - 650 mA														
Effective voltage range U	5-200 V															
Effective current range	$(0,75-100) \times I_s$															
Rated frequency f_r	50-60 Hz															
Operating frequency range	45-66 Hz															
Power consumption for $U = U_r$	<table border="0"> <tr> <td>50 mA variant</td> <td>$I = I_s = 5$ mA</td> <td>0,25 VA</td> </tr> <tr> <td></td> <td>$I = I_s = 50$ mA</td> <td>0,05 mVA</td> </tr> <tr> <td>200 mA variant</td> <td>$I = I_s = 20$ mA</td> <td>1 mVA</td> </tr> <tr> <td></td> <td>$I = I_s = 200$ mA</td> <td>0,1 mVA</td> </tr> <tr> <td></td> <td></td> <td>1,5 mVA</td> </tr> </table>	50 mA variant	$I = I_s = 5$ mA	0,25 VA		$I = I_s = 50$ mA	0,05 mVA	200 mA variant	$I = I_s = 20$ mA	1 mVA		$I = I_s = 200$ mA	0,1 mVA			1,5 mVA
50 mA variant	$I = I_s = 5$ mA	0,25 VA														
	$I = I_s = 50$ mA	0,05 mVA														
200 mA variant	$I = I_s = 20$ mA	1 mVA														
	$I = I_s = 200$ mA	0,1 mVA														
		1,5 mVA														
Overload capacity voltage: continuously during 10 s	250 V 300 V															
Overload capacity current: continuously	<table border="0"> <tr> <td>50 mA variant</td> <td>$I_s = 5/10/20/50$ mA</td> <td>0,5/1/1/1 A</td> </tr> <tr> <td>200 mA variant</td> <td>$I_s = 20/40/80/200$ mA</td> <td>2/4/4/4 A</td> </tr> </table>	50 mA variant	$I_s = 5/10/20/50$ mA	0,5/1/1/1 A	200 mA variant	$I_s = 20/40/80/200$ mA	2/4/4/4 A									
50 mA variant	$I_s = 5/10/20/50$ mA	0,5/1/1/1 A														
200 mA variant	$I_s = 20/40/80/200$ mA	2/4/4/4 A														
during 1 s	<table border="0"> <tr> <td>50 mA variant</td> <td></td> <td>5 A</td> </tr> <tr> <td>200 mA variant</td> <td></td> <td>20 A</td> </tr> </table>	50 mA variant		5 A	200 mA variant		20 A									
50 mA variant		5 A														
200 mA variant		20 A														

Start function

Current function	Stage I>			
Setting range I>	$(0,75-3,25) \times I_s$			
Angle between U and I, φ	Positive if I lags U			
Settable characteristic angle α	0° or -90° Uni- or Bi directional, see fig. 16			
Operate conditions for I>, at selected program (U>, I $_{\alpha}$ >) and (U enbl I) (U>, I $_{\alpha}$ >) and (I indep U) (U<, I>) and (U enbl I) (U<, I>) and (I indep U)	I x cos ($\varphi-\alpha$) \geq set I> and U \geq set U> I x cos ($\varphi-\alpha$) \geq set I> and U \geq 5 V I \geq set I> and U \leq set U< I \geq set I>			
Logic for phase memory low voltage phase memory low voltage timeout	Ignores angle changes when U < 5 V Blocks start function 1s after U has decreased to < 5 V			
Binary input 1 "α-selection" Active signal on binary input 1,	Changes the characteristic angle α from 0° to -90° or -90° to 0°			
Accuracy for characteristic angle α 1 to 8 x set op. value 8 to 25 x set op. value 25 to 100 x set op. value	I _s = 0,1 x I _r < 5,5°	I _s = 0,2 x I _r < 3,0°	I _s = 0,4 x I _r < 2,0°	I _s = 1,0 x I _r < 3,0°
	< 2,5°	< 2,0°	< 2,5°	< 2,5°
	< 1,5°	< 1,5°	< 2,0°	< 2,0°
Operate time at $\varphi = \alpha$, typical I = 0 => 3 x I> I = 0 => 10 x I>	Directional function 85 ms 80 ms		Non-directional function 20 ms 15 ms	
Reset time at $\varphi = \alpha$, typical I = 3 => 0 x I> I = 10 => 0 x I>	Directional function 30 ms 40 ms		Non-directional function 30 ms 40 ms	
Consistency of the op. value	< 3% at $\varphi=\alpha$		< 2%	
Reset ratio (typical)	90%			
Transient over-reach L/R=10, 50 and 100 ms	< 3%		< 4%	
Overshoot time	< 50 ms		< 20 ms	
Recovery time at I = 3 x I $_{\alpha}$ >	< 50 ms			
Frequency dependence 45-65 Hz	<± 5%		< 3%	
Influence of harmonics in:	Angle dependence		Current dependence	
Voltage circuit 100 / 120 Hz, 30%	< 2°		-	
150 / 180 Hz, 50%	< 5°		-	
150 / 180 Hz, 100%	< 7°		-	
250 / 300 Hz, 30%	< 2°		-	
Current circuit 100 / 120 Hz, 5%	< 2°		< 3%	
150 / 180 Hz, 10%	< 6°		< 3%	
150 / 180 Hz, 20%	< 9°		< 7%	
150 / 180 Hz, 30%	< 12°		< 7%	
250 / 300 Hz, 20%	< 7°		< 4%	
250 / 300 Hz, 30%	< 11°		< 6%	

Voltage function

Selected function U> or U<		U>	U<
Setting range U		$U = U_s = (5-30) \text{ V}$	$U = 4 \times U_s = (5-120) \text{ V}$
Operate time	Over-voltage (typical)		
	U = 0 => 1,1 x op. value	60 ms	–
	U = 0,9 => 1,1 x op. value	45 ms	–
	Under-voltage (typical)		
U = 2,0 => 0,9 x op. value	–	60 ms	
U = 1,1 => 0,9 x op. value	–	45 ms	
Reset time	Over-voltage (typical)		
	U = 1,1 => 0,9 x op. value	60 ms	–
	U = 1,1 => 0 x op. value	35 ms	–
	Under-voltage (typical)		
U = 0,9 => 1,1 x op. value	–	60 ms	
U = 0,9 => 2,0 x op. value	–	35 ms	
Consistency of the op. value		< 2%	
Reset ratio, (typical)		90%	110%
Overshoot time		< 40 ms	
Recovery time	Over-voltage		
	U = 0 => 1,1 x op. value	< 55 ms	–
	Under-voltage	–	< 55 ms
U = 2,0 => 0,9 x op. value			
Frequency dependence	45-55 Hz	< 2%	
	54-65 Hz	< 4%	
Influence of harmonics in:		Voltage dependence	
Voltage circuit	100 / 120 Hz, 30%	< 4%	
	150 / 180 Hz, 50%	< 2%	
	150 / 180 Hz, 100%	< 5%	
	250 / 300 Hz, 30%	< 2%	

Time function

Function	Stage I>	Stage U> or U<
Time delay	Definite time	
Setting range for definite time	$t_I = 0-10 \text{ s}$	$t_U = 0-20 \text{ s}$
Accuracy	1% and $\pm 50 \text{ ms}$	1% and $\pm 50 \text{ ms}$
Consistency	< 0,5%	< 0,5%

See also technical data common for RXPDK 21H, RXPDK 22H and RXPDK 23H

**5.7 Directional time-
overcurrent relay
RXPDK 23H**

Voltage and current inputs

Rated voltage U_r	120 V
Rated current I_r	1 A or 5 A
Scale constant I_s	1 A variant 5 A variant
	0,1, 0,2, 0,4 and 1,0 A 0,5, 1, 2, and 5 A
Scale range	
1 A Variant	$I_\alpha >$ $I >>$
	0,075-3,25 A 0,1-40 A
5 A Variant	$I_\alpha >$ $I >>$
	0,375-16,25 A 0,5-200 A
Effective voltage range U	0,5-500 V
Effective current range	$(0,75-90) \times I_s$
Rated frequency f_r	50-60 Hz
Operating frequency range	45-66 Hz
Power consumption for: U = 120 V	0,5 mVA
1 A variant	$I = I_s = 0,1$ A $I = I_s = 1$ A
	0,3 mVA 25 mVA
5 A variant	$I = I_s = 0,5$ A $I = I_s = 5$ A
	1,5 mVA 100 mVA
Overload capacity voltage:	
	continuously during 10 s during 1 s
	250 V 300 V 500 V
Overload capacity current:	
1 A variant	continuously
5 A variant	continuously
1 A variant	during 1 s
5 A variant	during 1 s
	4 A 20 A 100 A 350 A

Current functions

Current functions	Low set stage $I_{\alpha>}$	High set stage $I_{>>}$
Setting range	$(0,75-3,25) \times I_s$	$(1,0-40) \times I_s$ and •
Binary inputs Active signal on binary input 1 Active signal on binary input 2	Blocks or enables the trip functions Reset LEDs	
Angle φ between U and I	Positive if I lags U	–
Operate condition $I_{\alpha>}$	$140^\circ \geq \varphi \geq 0^\circ$ AND $I \geq \text{set } I_{\alpha>}$ See figure 17	–
Operate time at $\varphi = \alpha$, typical $I = 0 \Rightarrow 3 \times I_{\alpha>}$ $I = 0 \Rightarrow 10 \times I_{\alpha>}$	75ms 70ms	35 ms 30 ms
Reset time at $\varphi = \alpha$, typical $I = 3 \Rightarrow 0 \times I_{\alpha>}$ $I = 10 \Rightarrow 0 \times I_{\alpha>}$	55 ms 65 ms	50 ms 60 ms
Consistency of the op. value	$< 2\%$ at $\varphi = \alpha$	$< 2\%$
Reset ratio (typical)	90%	90%
Transient over-reach L/R=10, 50 and 100 ms	$< 5\%$	$< 5\%$
Overshoot time	< 60 ms	< 35 ms
Recovery time at $I = 3 \times I_{\alpha>}$	< 35 ms	< 30 ms
Frequency dependence 45-65 Hz	$\pm 5\%$	
Influence of harmonics in: Voltage circuit 100 / 120 Hz, 30% 150 / 180 Hz, 100% 150 / 180 Hz, 200% 250 / 300 Hz, 200% Current circuit 100 / 120 Hz, 10% 150 / 180 Hz, 10% 250 / 300 Hz, 20%	Angle dependence $< 2^\circ$ $< 8^\circ$ $< 15^\circ$ $< 5^\circ$ $< 2^\circ$ $< 5^\circ$ $< 6^\circ$	Current dependence $< 3\%$ $< 4\%$ $< 3\%$

Time functions

Time function	Low set stage $I_{\alpha>}$	High set stage $I_{>>}$
Time delay	Inverse and definite time (Normal, Very and Extremely inverse time)	
Setting range Definite time Inverse time	0,05-8,1 s $k = 0,05-1,1$	0,03 - 10 s
Accuracy Definite time Inverse time Consistency	The tolerances for inverse and definite time delay are calculated under the condition that the current before operation is higher than $0,4 \times I_s$, otherwise add 20-30 ms. $\pm(1\% + 50 \text{ ms})$ NI, VI, EI 1,3 x op. value $\pm(12,5\% + 30 \text{ ms})$ NI, VI, EI 2 x op. value $\pm(12,5\% + 30 \text{ ms})$ NI, VI, EI 3 x op. value $\pm(10,9\% + 30 \text{ ms})$ NI, VI, EI 5 x op. value $\pm(7,5\% + 30 \text{ ms})$ NI, VI, EI 10 x op. value $\pm(5\% + 30 \text{ ms})$ NI 20 x op. value $\pm(5\% + 30 \text{ ms})$ VI, EI 20 x op. value $\pm(5\% + 30 \text{ ms})$ $< 0,5\%$	

See also technical data common for RXPDK 21H, RXPDK 22H and RXPDK 23H

5.8 Technical data common for RXPDK 21H, RXPDK 22H and RXPDK 23H

Auxiliary DC voltage supply

Auxiliary voltage EL for RXTUG 22H Auxiliary voltage to the relay	24-250 V DC, $\pm 20\%$ ± 24 V (from RXTUG 22H)
Power consumption at RXTUG 22H input 24-250 V before operation after operation	Max. 6,5 W Max. 7,5 W
without RXTUG 22H ± 24 V before operation after operation	Max. 3,0 W Max. 4,0 W

Binary input

Binary input voltage RL	48-60 V and 110-220 V DC, -20% to +10%
Power consumption	48-60 V Max. 0,3 W 110-220 V Max. 1,5 W

Output relays

Contacts	3 change-over
Maximum system voltage	250 V AC / DC.
Current carrying capacity continuous during 1 s	5 A 15 A
Making capacity at inductive load with L/R >10 ms during 200 ms during 1 s	30 A 10 A
Breaking capacity AC, max. 250 V, $\cos \varphi > 0,4$ DC, with L/R < 40 m	8 A 1 A 0,4 A 0,2 A 0,15 A

Electromagnetic disturbance tests

All tests are done together with the DC/DC-converter, RXTUG 22H

Test	Severity	Standard
Surge immunity test	1 and 2 kV, normal service 2 and 4 kV, destructive test	IEC 61000-4-5, class 3 IEC 61000-4-5, class 4
AC injection test	500 V, AC	SS 436 15 03, PL 4
Power frequency field immunity test	1000 A/m	IEC 61000-4-8
1 MHz burst test	2,5 kV	IEC 60255-22-1, class 3
Spark test	4-8 kV	SS 436 15 03, PL 4
Fast transient test	4 kV	IEC 60255-22-4, class 4
Electrostatic discharge test In normal service with cover on	8 kv (contact) 15 kv (air) 8 kV, indirect application	IEC 60255-22-2, class 4 IEC 60255-22-2, class 4 IEC 61000-4-2, class 4
Radiated electromagnetic field test	10 V/m, 26-1000 MHz	IEC 61000-4-3, Level 3
Conducted electromagnetic test	10 V, 0,15-80 MHz	IEC 61000-4-3, Level 3
Interruptions in auxiliary voltage 110 VDC, no resetting for interruptions	2-200 ms < 40 ms	IEC 60255-11

Electromagnetic emission tests

Test	Severity	Standard
Conducted	0,15-30 MHz, class A	EN 50081- 2
Radiated emission	30-1000 MHz, class A	EN 50081- 2

Insulation tests

Test	Severity	Standard
Dielectric test Circuit to circuit and circuit to earth Over open contact	2,0 kV AC, 1 min 1,0 kV AC, 1 min	IEC 60255-5
Impulse voltage test	5 kV, 1,2/50 μ s, 0,5 J	IEC 60255-5
Insulation resistance	> 100 M Ω at 500 V DC	IEC 60255-5

Mechanical tests

Test	Severity	Standard
Vibration	Response: 2,0 g, 10-150-10 Hz Endurance: 1,0 g, 10-150-10 Hz, 20 sweeps	IEC 60255-21-1, class 2 IEC 60255-21-1, class 1
Shock	Response: 5 g, 11 ms, 3 pulses Withstand: 15 g, 11 ms, 3 pulses	IEC 60255-21-2, class 1
Bump	Withstand: 10 g, 16 ms, 1000 pulses	IEC 60255-21-2, class 1
Seismic	X axis: 3,0 g, 1-35-1 Hz Y axis: 3,0 g, 1-35-1 Hz Z axis: 2,0 g, 1-35-1 Hz	IEC 60255-21-3, class 2, extended (Method A)

Temperature range

Storage	-20 °C to +70 °C
Permitted temperature range	-5 °C to +55 °C

Weight and dimensions

Equipment	weight	Height	Width
RXPDK 21H without RXTUG 22H	0,7 kg	4U	6C
RXPDK 22H without RXTUG 22H	0,7 kg	4U	6C

5.9 Inverse time characteristics

The different types of inverse time characteristics, used for relays RXIDK and RXPDK are shown in the figures below:

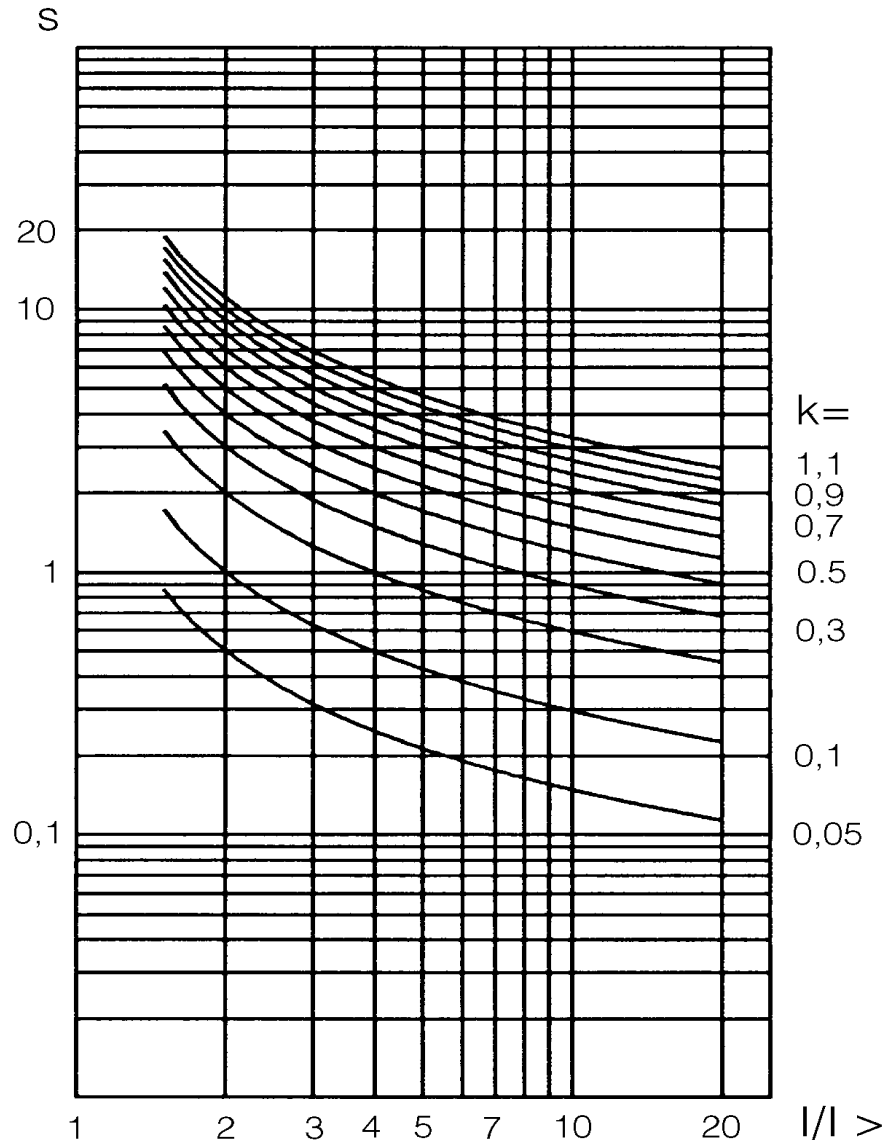

Fig. 35 Normal inverse characteristic

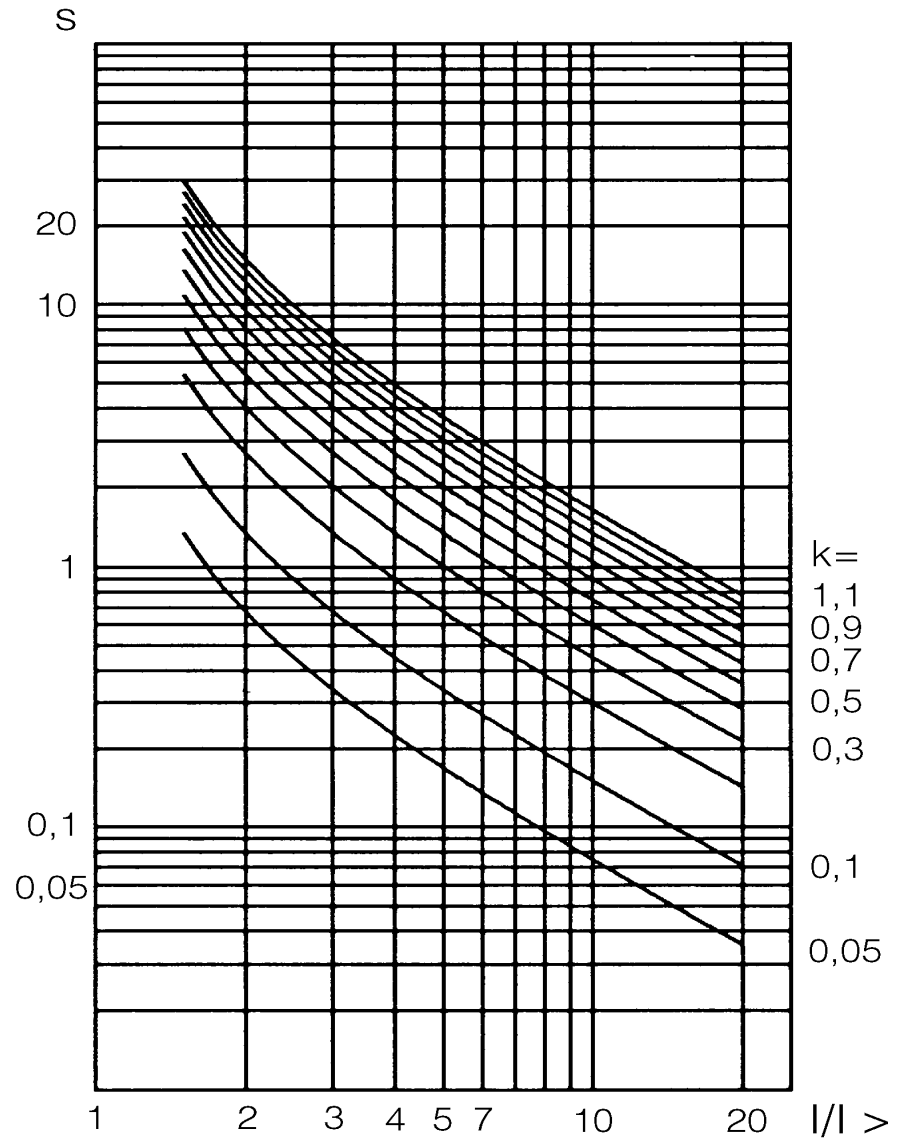

Fig. 36 Very inverse characteristic

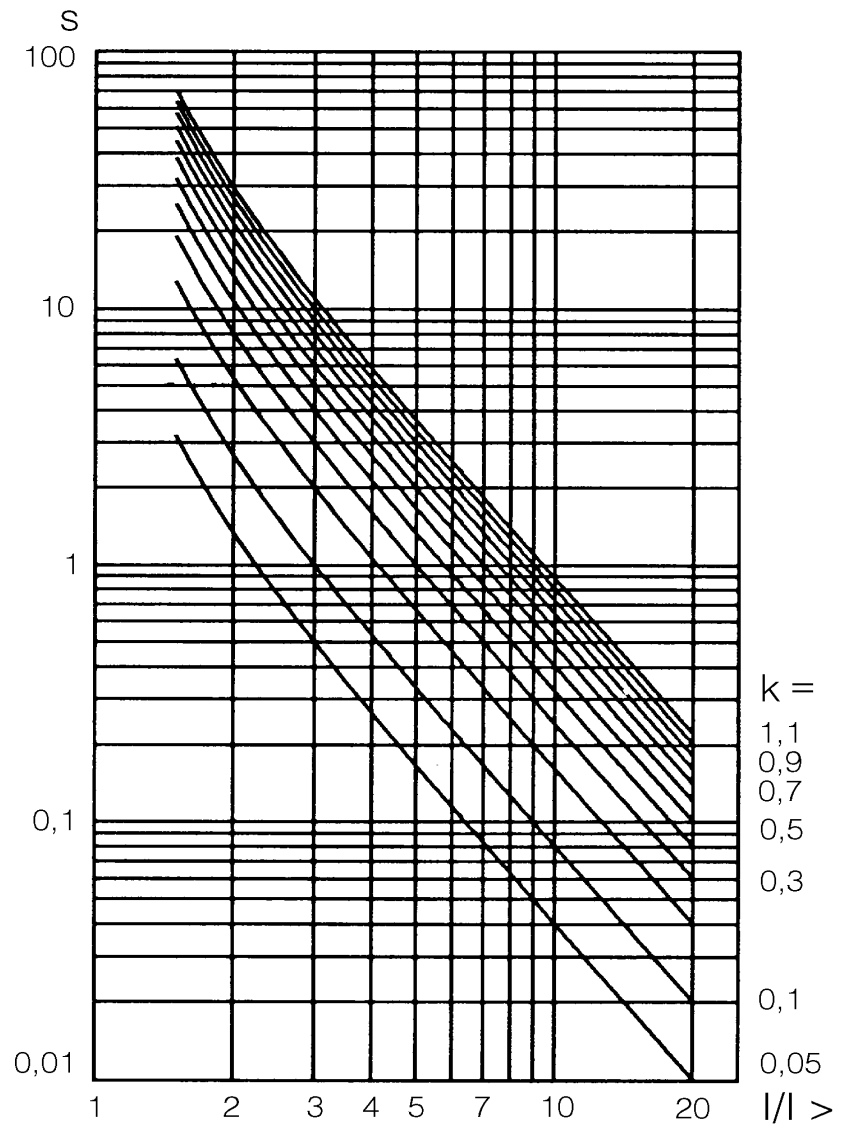

Fig. 37 Extremely inverse characteristic

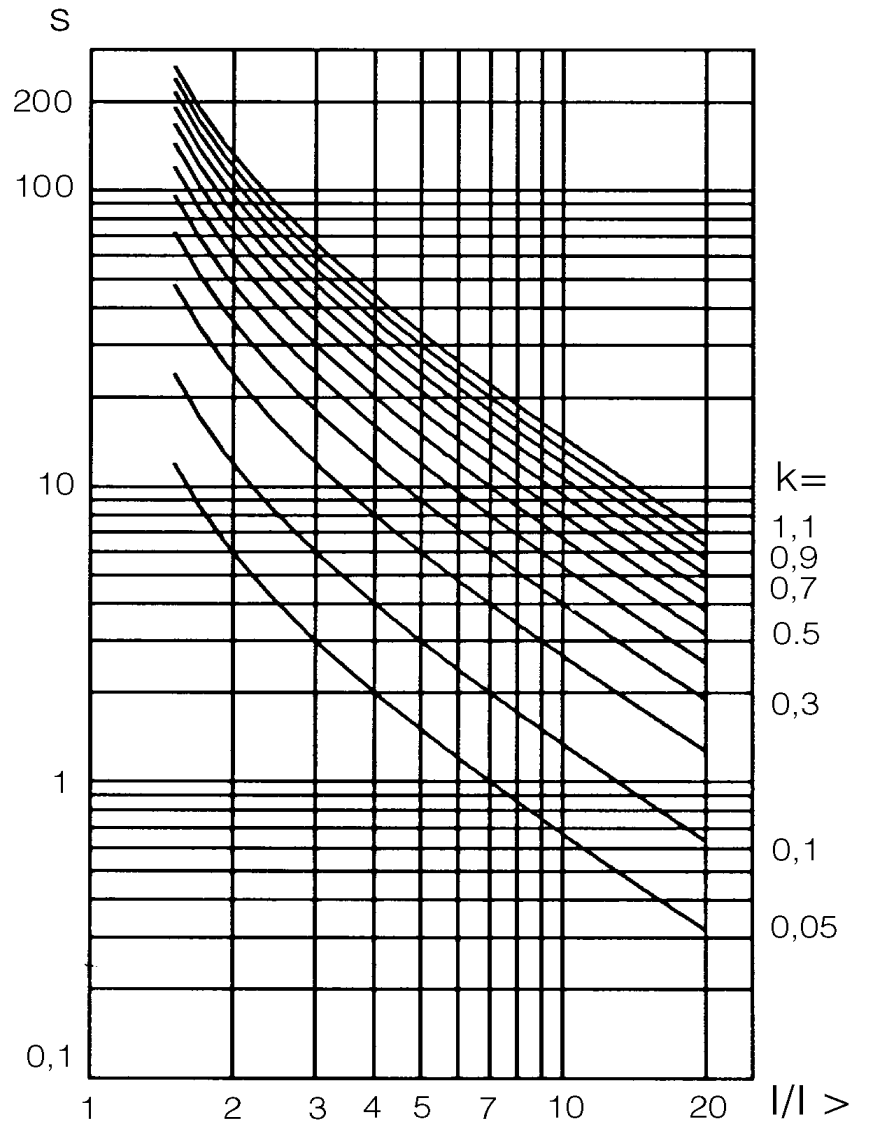

Fig. 38 Long-time inverse characteristic

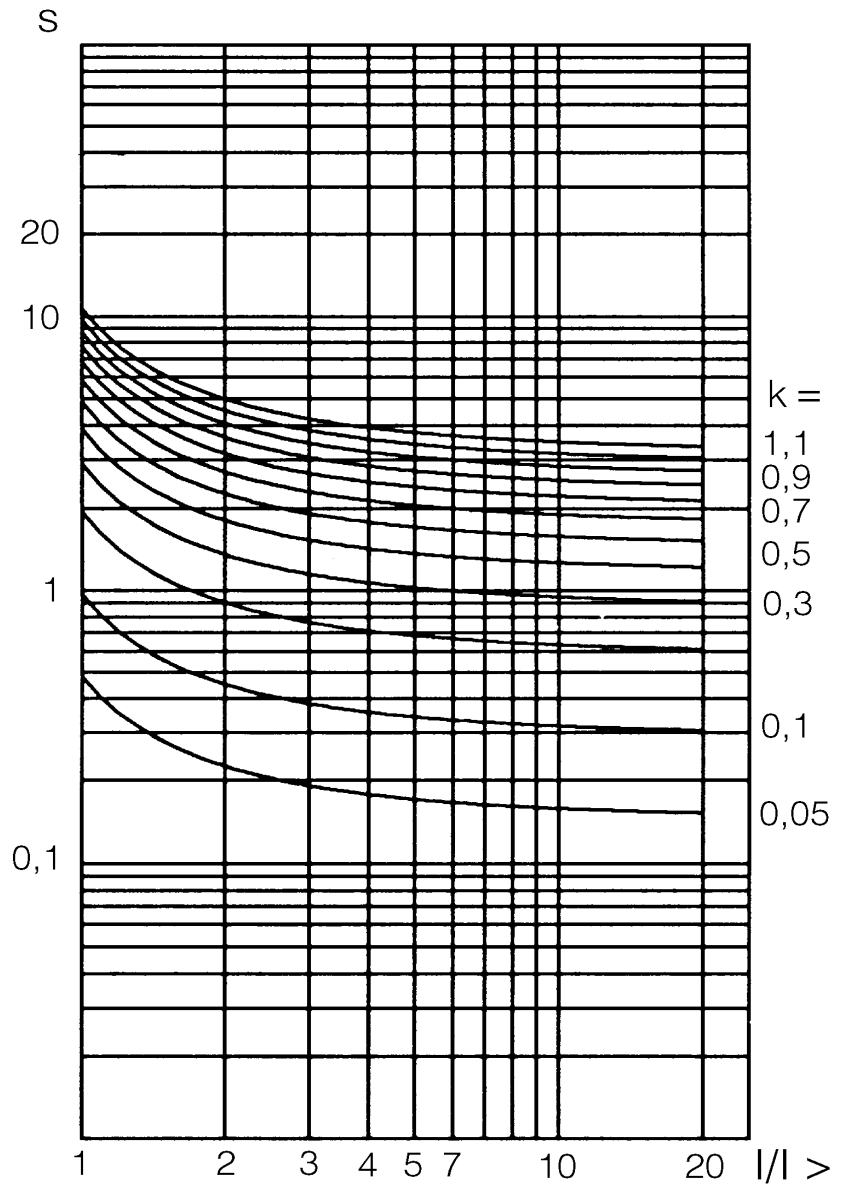

Fig. 39 *RI inverse characteristic*

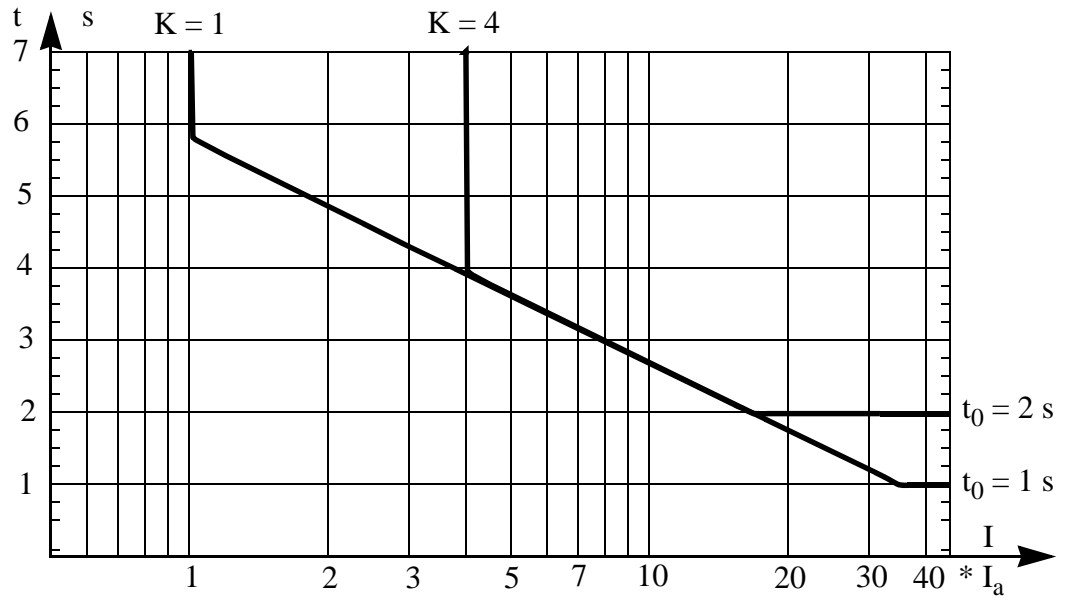

Fig. 40 Logarithmic inverse characteristic

6 Receiving and Handling and Storage

6.1 Receiving and Handling

Remove the protection package from the transport case and make a visual inspection for transport damages. Check that all screws are firmly tightened and all relay elements are securely fastened.

Check on the rating plate that the over-current units has the correct scale constant I_s . Check that all units are included in accordance with the apparatus list.

Normal ESD (Electrostatic Discharge) precautions for microprocessor relays should be observed when handling the packages and separate relay units.

6.2 Storage

If the protection package is to be stored before installation, this must be done in a dry and dust-free place, preferably in the original transport case.

7 Installation, Testing and Commissioning

7.1 Installation

The relays and the RXTUG 22H DC-DC converter are plugged into COMBIFLEX[®] terminal bases type RX 4 or RX 2H. The terminal bases and the RTXT test switch, when included, are fixed on apparatus bars to make up the protection assembly.

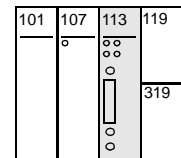
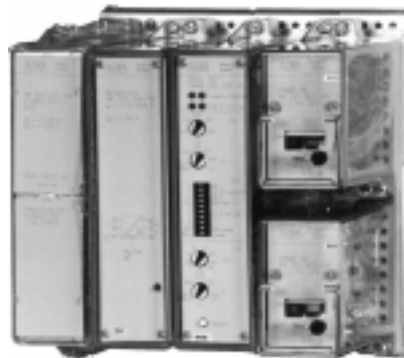

101 RTXP 18
107 RXTUG 22H
113 RXIDK 2H
119 RXME 18
319 RXME 18

Fig. 41 RAIDK single-phase overcurrent protection

The protection assembly can be mounted in the following ways:

- on apparatus bars
- in a 19" equipment frame
- in RHGX case
- in RHGS case

The height and width of the protection assembly are given in the circuit diagram with height (U) and width (C) modules, where $U = 44,45$ mm and $C = 7$ mm. The depth of the protection assembly, including space for the connection wires, is approximately 200 mm.

All internal connections are made and the protection assembly is tested before delivery from factory.

19" equipment frames

Detailed information on the COMBIFLEX® connection and installation components is given in Catalogue 1MRK 513 003-BEN. Information on the relay mounting system is given in Catalogue 1MRK 514 001-BEN.

Case RHGS

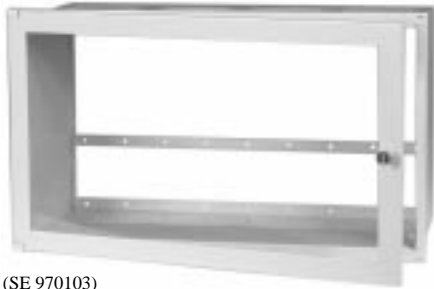

(SE 970103)

Fig. 42 RHGS case

RHGS cases for 19" cubicle mounting or surface mounting

This type of case can be used for all common ways of mounting. The RHGS cases are available in three different sizes, which can be combined with mounting accessories to get maximum flexibility. The cases can also be combined together with the protections in the 500 range.

RHGX 8



(SE 81702)

Fig. 43 RHGX case

RHGX cases for flush- or semi-flush panel mounting

The RHGX cases are available in five sizes. The case, a metal box open at the back, has a flange (with a rubber sealing strip) at the front which acts as a stop when the case is inserted into a front panel opening. At the front of the case there is a door with a window and a rubber seal.

Size: 4U 19"



(SE 96399)

Fig. 44 19" equipment frame

19" equipment frames

These types of equipment frames are used for cubicle mounting or panel mounting of plug-in units in the COMBIFLEX™ range. The frames are available in 3 sizes:

4U (17" x 19")

8U (14" x 19")

12U (21" x 19")

for mounting 20, 40 and 60 module seats respectively.

Connections

The external connections (dotted lines on the terminal and circuit diagrams) are made with leads with 20 A COMBIFLEX[®] sockets to the RTXP 18 test switch and with 10 A sockets to the relay terminal bases.

Each unit in the protection assembly has a unique item designation. The item designations are based on a coordinate system of U and C modules, where the first figure stands for the U-module position starting from the left-hand side - seen from the front side of the protection assembly - and the next two figures stand for the C-module position, starting from the top. The RTXP test switch in Fig. 45 has item designation 101, where the first figure stands for the U-module position and the next two figures stand for the C-module designation.

The terminal designations include the item designation number of the unit followed by the terminal number marked on the rear of the terminal socket.

For plug-in units size 2H an additional figure 1 or 3 defines if the terminal is in the upper resp. lower part of the assembly. Compare terminal designations 107:118 and 107:318 in Fig. 46.

Fig. 46 shows the rear of protection assembly RAIDK, Order No. 1MRK 001 002-EA. The position of the terminals, which are used for external connections acc. to connection diagram 1MRK 001 003-EAA, is shown.

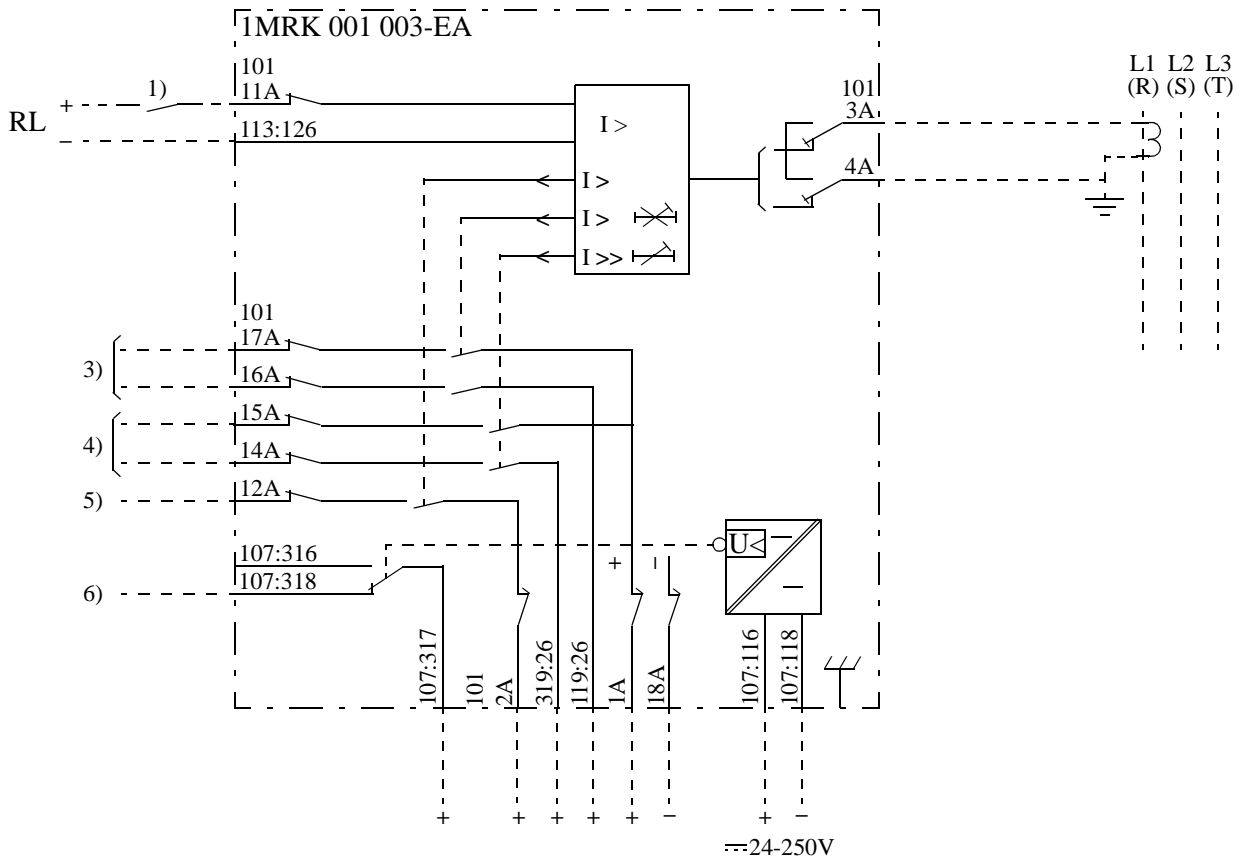

Fig. 45 Terminal diagram 1MRK 001 003-EAA

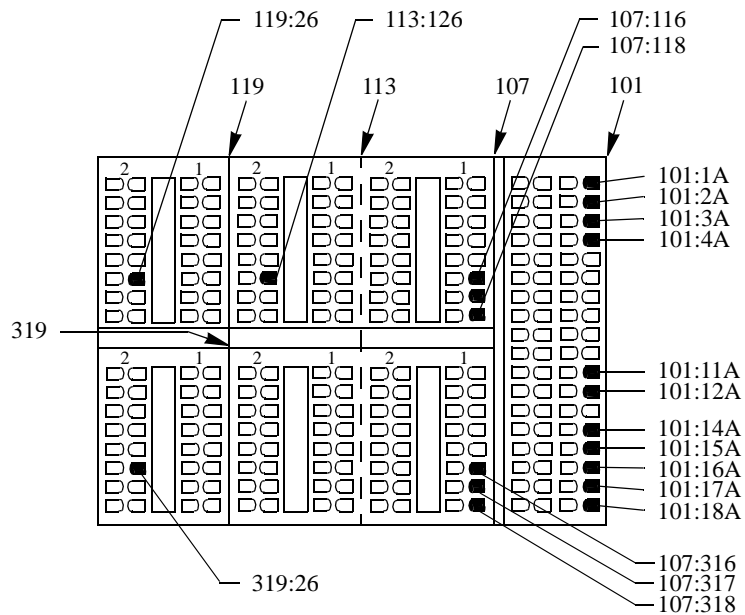

Fig. 46 Location of the terminals shown on diagram
1MRK 001 003-EAA

7.2 Testing

Secondary injection testing

The standard relays (Order No's 1MRK 001 0xx-xA) are provided with the COMBITEST test switch type RTXP 18.

When the test-plug handle RTXP 18 is inserted in the test switch, preparations for testing are automatically carried out in the proper sequence, i.e. blocking of tripping circuits, short-circuiting of CT's, opening of VT circuits, making relay terminals accessible for testing.

When the test handle is in the intermediate position, only the tripping circuits are opened. When the test handle is fully inserted, the relay is completely disconnected from the instrument transformers and ready for secondary injection testing.

Relays which are not provided with test switch have to be tested in the proper way from external circuit terminals.

The protection assemblies dealt with in this User's Guide are made up of separate measuring units for each phase current and, when included, earth-fault current. Protection assemblies with non-directional phase current relays and non-directional earth-fault relay can conveniently be tested with a single-phase test set, e.g. the SVERKER test set with built-in timer. Even protection assemblies with directional phase current relays and directional earth-fault relay can be tested with a single-phase test, see below. They are however, more conveniently tested with a three-phase test set, e.g. the FREJA computer-aided test set with three-phase current and three-phase voltage output.

7.2.1 Testing of 50 and 60 Hz protection assemblies with non-directional current relays

Suitable test equipment:

- Test set SVERKER
- Multimeter or Ammeter, Class 1 or better
- RTXH 18 test plug with test leads

Fig. 47 shows as an example the connection of test set SVERKER for secondary testing of the 3-phase overcurrent and earth-fault protection RAIDK 4, Connection Diagram 1MRK 001 003-VAA. When testing, even the actual circuit diagram of the protection, which shows the internal connections, should be available.

1. Connect the test set and the ammeter acc to Fig. 47 to test the relay functions for phase L1 and insert the test-plug into the test switch. Auxiliary voltage shall be connected to terminals 101:1A and 101:2A. Interconnect terminals 1 and 2 on the test handle to get output voltage to test terminals 12 and 13 when the start function is activated for a phase overcurrent resp. earth-fault relay.

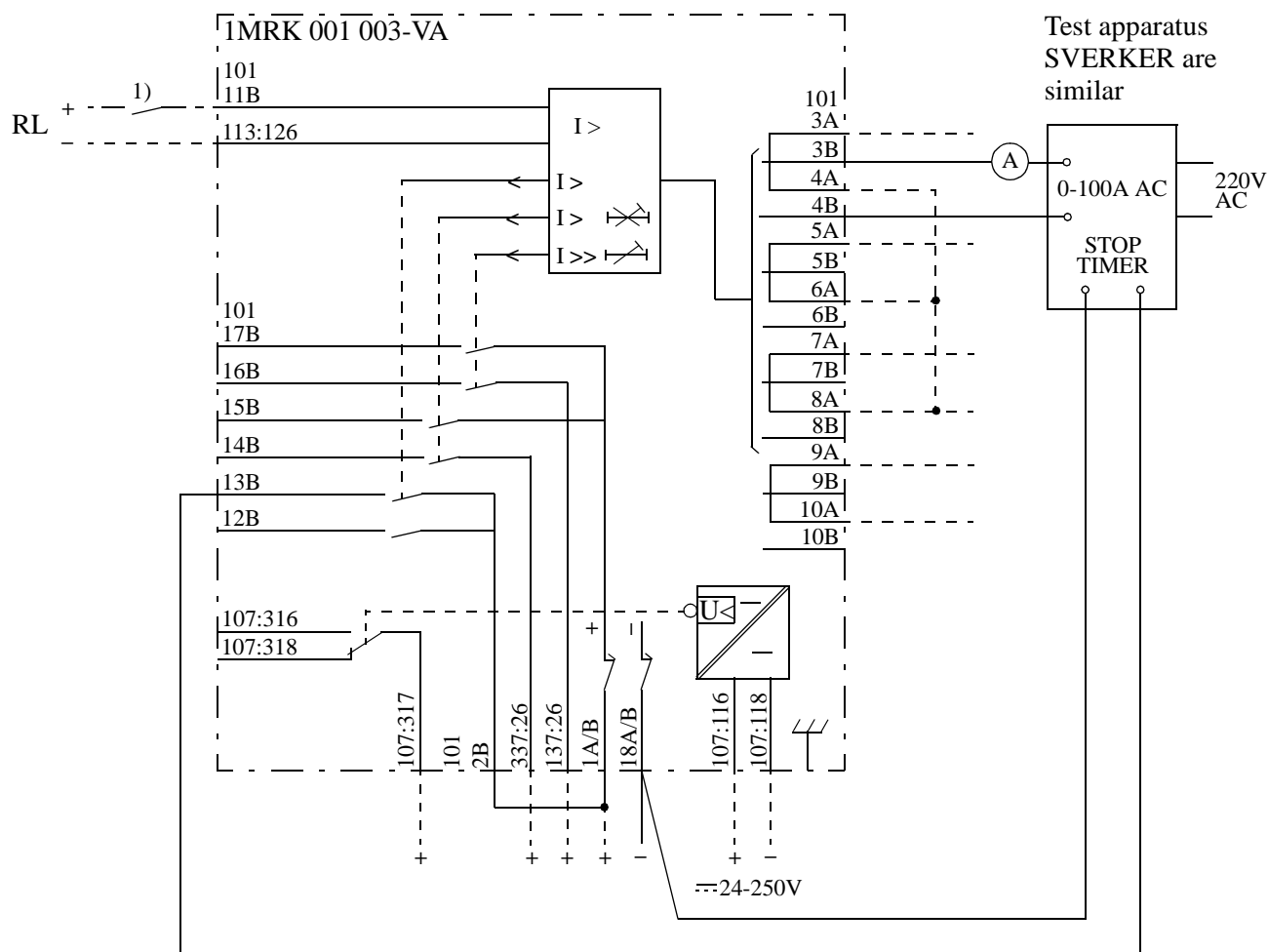

Fig. 47 Connection of test apparatus for testing of phase L1

2. Make the appropriate settings of relay operate currents, time delays and the function of the digital input. Guide for the setting of the switches and potentiometers on the front of the relays is given in Section 4.2, Setting.

Connect auxiliary voltage to test terminal 11 to activate the digital input if this is required for the relay function.

3. Increase the injection current until the low set stage start relay (I>) for phase L1 operates (output voltage on test terminal 13). Check also that the LED indicator for start is activated when I> operates. Check the resetting value.

If the relay is programmed for “cold load “function, check that the operating current increases 40% when the digital input is activated.

4. Move the timer stop wire from test terminal 13 to test terminal 15. If definite time delay is selected, increase the current to twice the operate value of I> and check the time delay. If inverse time delay is selected,

check the operate time at two points on the inverse time characteristic, e.g. at twice and ten times the operate value of $I_{>}$. Check that the LED indicator for time delayed tripping is activated.

Check the operate time correspondingly for “cold load” with 40% increment of the current. Check that trip output is obtained on test terminal 14 when auxiliary voltage is connected to terminal 337:26.

5. Move the timer stop wire to test terminal 17 and check the operate current of stage $I_{>>}$. Increase the current to twice the operate value and check the time delay. Check that the LED indicator for high current stage tripping is activated. Check that trip output is obtained on test terminal 16 when auxiliary voltage is connected to terminal 137:26. Check the resetting value.

6. Check in the same way the relay function for phases L2 and L3 and the earth-fault relay.

7.2.2 Testing of 50 and 60 Hz directional current relays with single-phase test set

When testing protections with directional relays RXPDK 21H/22H, a polarising voltage ≥ 5 V must be applied to each individual phase or earth-fault RXPDK relay when testing the directional current function $I_{\alpha>}$. When the phase angle of the polarising voltage relative the injection current is equal to the set characteristic angle of the relay, the operate value is equal to the setting. A positive value of the set characteristic angle ϕ means that the polarising voltage shall lead the injection current.

Otherwise, the current and time-lag functions of the individual directional phase and earth-fault relays are in principle checked as described above for non-directional relays.

The directional relays can be tested with test set SVERKER, making use of the built-in 10 μ F capacitor and resistors to get a polarising voltage with suitable phase angle.

Test equipment:

- Test set SVERKER
- 2 pcs Multimeter, Class 1 or better
- RTXH 18 test plug with test leads
- 1 or 2 adjustable resistors, depending on type of relay, see below.

Relays with positive characteristic angle

The connections shown on Fig.48 are used for testing of relays with positive characteristic angle. With $C = 10$ μ F, $R_F = 184$ Ω and $f = 50$ Hz, the voltage to relay terminals 324-325 will lead the current injected into relay terminal 331 by 60 degrees ($\phi = 60^\circ$).

The angle φ can with sufficient accuracy be determined by measuring the ratio between the voltages U_C and U_R and is set equal to the characteristic value of the relay by adjusting the resistance value R_F .

$$\varphi = \tan^{-1} U_C / U_R$$

φ°	30	40	50	60	70
U_C/U_R	0,58	0,84	1,19	1,73	2,75

Resistor R_S is included to get sufficient polarising voltage (≥ 5 V) to the relay. When testing relays with high current settings, it may be necessary to use an external resistor instead of the built-in resistors in SVERKER.

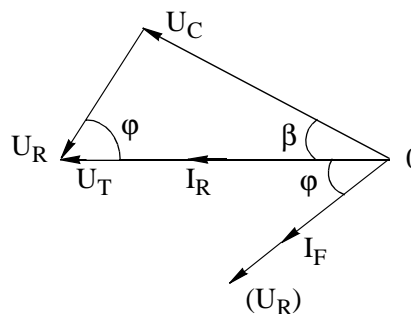
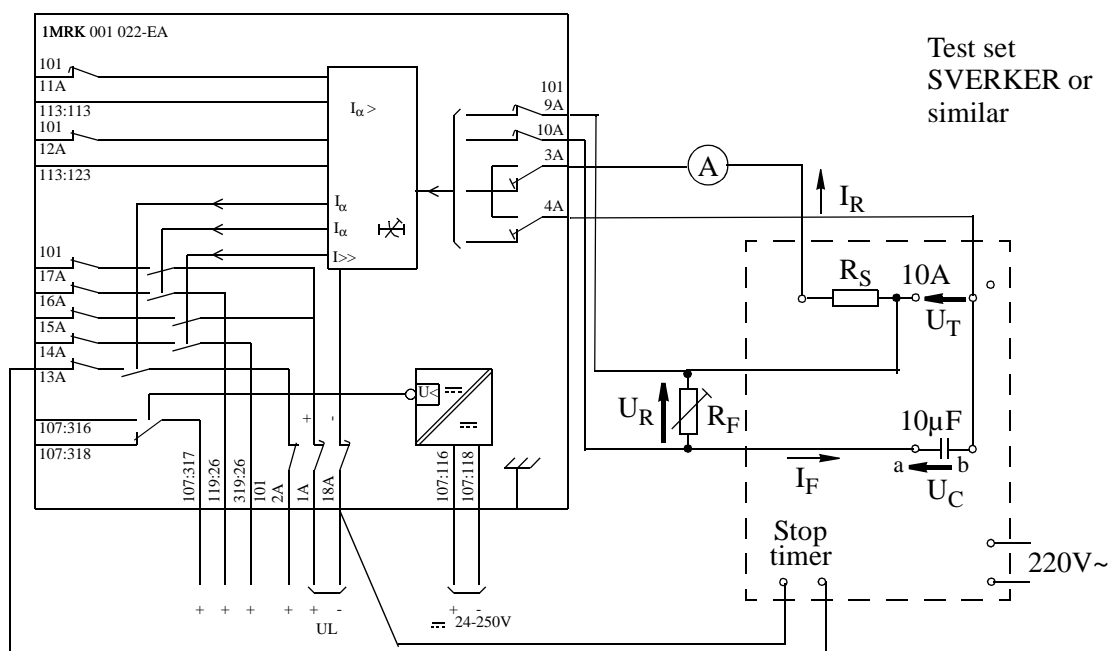

Fig. 48 Testing of directional relay RXPDK 21H with positive characteristic angle α . Principle diagram

Earth-fault relays for resistance earthed systems

For earth-fault relays with characteristic angle $\alpha = 0^\circ$, the voltage across resistor R_S is used as polarising voltage. Note! The terminal marked "10A" on Fig. 48 shall be connected to relay terminal 324 to get correct polarity.

Earth-fault relays for unearthed systems

For earth-fault relays with characteristic angle $\alpha = -90^\circ$, the resistance value R_F is selected in the range 1,3 - 1,6 k Ω and the voltage U_C across the capacitor is used as polarising voltage.

The voltage ratio $U_R/U_C = 4,7$ gives a phase angle $\beta = -78^\circ$. The operate value of the injection current is then increased to 1,02 times the set value for $\alpha = -90$.

Note! Terminal a on Fig 48 shall be connected to relay terminal 324 to get correct polarity.

Earth fault relay RXPDK 23H with fixed operate angle $140^\circ \geq \varphi \geq 0^\circ$ can be tested with SVERKER acc. to Fig 49, using the 10 μ F capacitor and a variable resistor connected as shown in Fig. 50 to get a polarising voltage leading the injection current by 140° . The load on the capacitor should be limited to the high impedance of the 120 V voltage input circuit of the relay

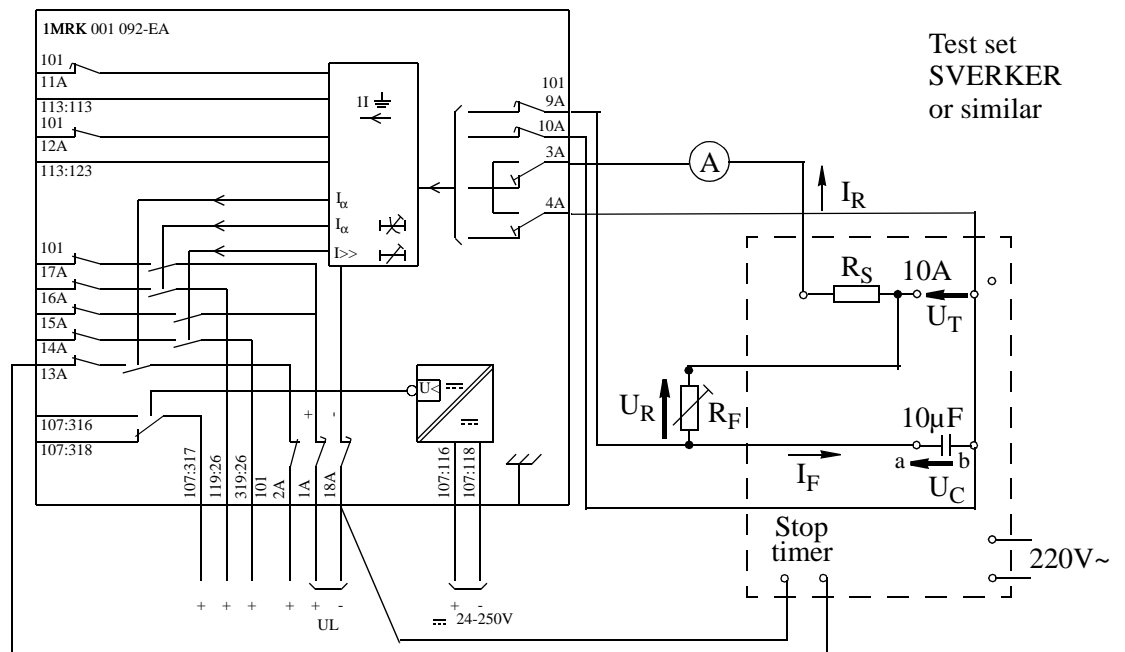

Fig. 49 Connection of test apparatus to earth fault prot. RAPDK 231

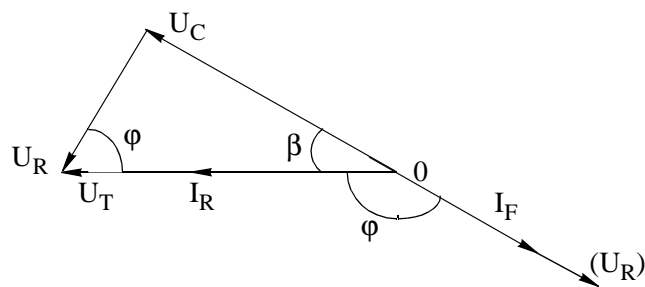

Fig. 50 Principle diagram

The phase angle shift φ of the voltage $-U_C$ relative to the injection current I_R is $\varphi = 90 + \tan^{-1} U_C / U_R$
Hence the ratio $U_C / U_R = 1,19$ gives $\varphi = 140^\circ$

Check the operate current $I_{\alpha} >$ and operate angle appr. $\varphi = 140^\circ$ by varying the resistor U_F . Check $I_{\alpha} >$ for two more points, e.g. $\varphi = 30^\circ$ and 70° with circuit connected acc. to Fig. 49

Directional phase current relays

Directional phase-current relays RXPDK 21H are as standard connected with its current circuit in one phase and its voltage circuit between the other two phases. The relays are normally set with characteristic angle $\alpha = -30^\circ$. The voltage U_C across the capacitor is used as polarising voltage for the relay, and the voltage ratio $U_R / U_C = 0,58$ gives angle $\beta = -30^\circ$. For other values, β is calculated acc. to $\beta = \tan^{-1} U_R / U_C$

β°	-30	-40	-50	-60	-70
U_R / U_C	0,58	0,84	1,19	1,73	2,75

Note! Terminal a of the capacitor, Fig 48 shall be connected to relay terminal 324 to get correct polarity.

The impedance of the voltage input circuit of the relay must be $10 \text{ k}\Omega$ or higher to keep the phase angle shift across the capacitor within max 2 degrees from the expected value.

7.3 Commissioning

The commissioning work includes check of all external circuits connected to the protection and check of current ratio for the CT's. For directional protections, the current and voltage ratio and also the correct polarity should be checked for the CT's resp. VT's.

The DC circuits and tripping circuits should be checked, including operation of the circuit-breaker(s).

A directional test should always be carried out before a directional protection is taken into service.

7.3.1 Directional test of the earth-fault relay

To carry out the following tests, the protected line must be in service and carry some active load current.

Relays with set characteristic angle $\alpha = 0$ to $+90^\circ$

Simulation of an earth-fault is made as follows:

1. Disconnect the phase L1 voltage from the VT open delta.
2. Short-circuit the secondary winding of the CT in phase L3 and disconnect it from the relay protection, see Fig. 51. An active load current out in the direction of the line will give a current to the relay which lags the polarising voltage by 60° .
3. A reactive load current out in the direction of the line will give a current which lags the polarising voltage by 150° .

A symmetrical load current will then give operation in the forward direction of the earth-fault relay when:

$$I_{act} \cdot \cos(\alpha - 60) + I_{react} \cdot \sin(\alpha - 60) \geq I_\alpha$$

where

I_α = set operate current of the earth-fault relay.

$$I_{act} = P/3U$$

$$I_{react} = Q/3U$$

P and Q are defined positive when the active respective reactive power is flowing out into the line and U is the primary phase voltage.

If the load current is flowing in the opposite direction, the polarising voltage UL1 has to be shifted 180° to get relay operation.

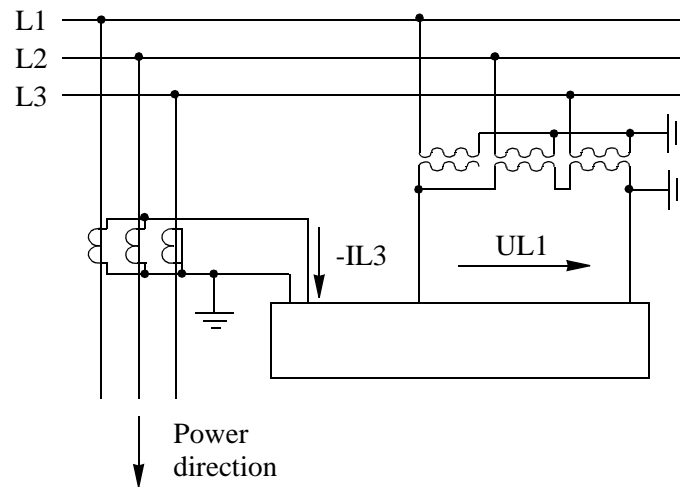

Fig. 51 Directional testing of earth-fault relay with characteristic angle $\alpha = 0$ to $+90^\circ$

Relays with set characteristic angle $\alpha = -90^\circ$

Simulation of an earth-fault is made as follows:

1. Disconnect the phase L1 voltage from the VT open delta.
2. Short-circuit the secondary winding of the CT in phase L2 and disconnect it from the relay protection, see Fig. 52. An active load current out in the direction of the line will give a current to the relay which leads the polarising voltage by 60° .
3. A reactive load current out in the direction of the line will give a current which lags the polarising voltage by 30° . A symmetrical load current will then give operation in the forward direction of the earth-fault relay when:

$$I_{act} \cdot \cos 60 + I_{react} \cdot \cos 30 \geq I\alpha$$

If the load current is flowing in the opposite direction, the polarising voltage UL1 has to be shifted 180° to get relay operation.

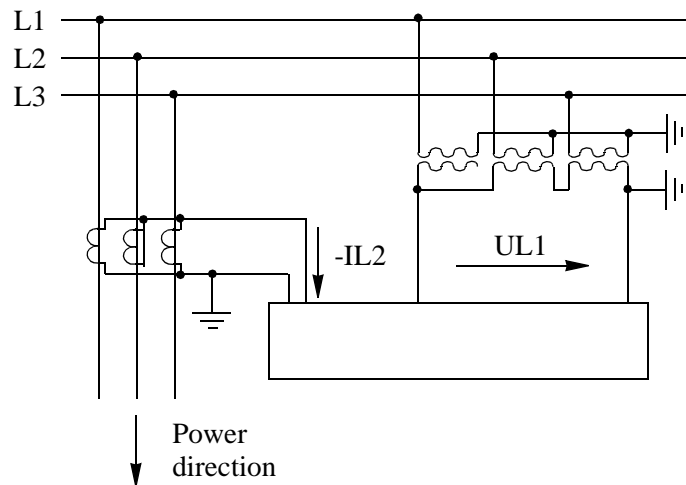

Fig. 52 Directional testing of earth-fault relay with characteristic angle $\alpha = -90^\circ$

Note! Restore the correct connections after testing.

Polarity check of directional phase over-current relays

Functional testing of the directional phase over-current relays can not easily be made using load currents. When the direction and load angle of the primary current is known, the phase angle between the polarising voltage and the current to each phase directional relay can be checked with a phase angle meter and compared to the expected value. The phase current is conveniently connected to the meter by means of the RXTM ammeter plug. The directional relay operates at set current when the phase angle between the voltage to relay terminals 324 - 325 and the current flowing into relay terminal 331 is equal to the set characteristic angle of the relay. Characteristic angle $\alpha = -30^\circ$ means that the relay has its highest sensitivity when the current is leading the polarising voltage by 30° .

8 Maintenance

Under normal conditions, the over-current protection relays require no special maintenance. The covers should be mounted correctly in position and the holes for the resetting knobs sealed with plastic plugs.

In exceptional cases, burned contacts on the output relays can be dressed with a diamond file.

Under normal operating conditions, and when the surrounding atmosphere is of non-corrosive nature, it is recommended that the relays be routine tested every four to five years.

9 Circuit and terminal diagrams

The tables below show the different variants of the protections RAIDK, RAIDG, RAPDK and RACIK.

One-, two or three-phase overcurrent protection and/or earth-fault protection with the measuring relay(s) RXIDK 2H

Type	Function	Test switch	DC-DC converter	Tripping relays	Ordering No. 1MRK 001	Circuit Diagram 1MRK 001	Terminal diagram 1MRK 001	Diagram
RAIDK 1	I > or IN	x			002-BA	003-BA	003-BAA	On request
RAIDK 1	I > or IN		x		002-CA	003-CA	003-CAA	On request
RAIDK 1	I > or IN	x	x		002-DA	003-DA	003-DAA	On request
RAIDK 1	I > or IN	x	x	x	002-EA	003-EA	003-EAA	On request
RAIDK 2	2I >	x			002-GA	003-GA	003-GAA	On request
RAIDK 2	2I >		x		002-HA	003-HA	003-HAA	On request
RAIDK 2	2I >	x	x		002-KA	003-KA	003-KAA	On request
RAIDK 2	2I >	x	x	x	002-LA	003-LA	003-LAA	On request
RAIDK 3	2I > + IN	x			002-NB	003-NB	003-NBA	On request
RAIDK 3	2I > + IN		x		002-YB	003-YB	003-YBA	On request
RAIDK 3	2I > + IN	x	x		002-PB	003-PB	003-PBA	On request
RAIDK 3	2I > + IN	x	x	x	002-ZB	003-ZB	003-ZBA	On request
RAIDK 3	3I >	x			002-NA	003-NA	003-NAA	On request
RAIDK 3	3I >		x		002-YA	003-YA	003-YAA	On request
RAIDK 3	3I >	x	x		002-PA	003-PA	003-PAA	On request
RAIDK 3	3I >	x	x	x	002-ZA	003-ZA	003-ZAA	On request
RAIDK 4	3I > + IN	x			002-SA	003-SA	003-SAA	On request
RAIDK 4	3I > + IN		x		002-TA	003-TA	003-TAA	On request
RAIDK 4	3I > + IN	x	x		002-UA	003-UA	003-UAA	On request
RAIDK 4	3I > + IN	x	x	x	002-VA	003-VA	003-VAA	Fig. 53, 54

Earth-fault protection with the measuring relay RXIDG 21H

Type	Function	Test switch	DC-DC converter	Tripping relay	Ordering No. 1MRK 001	Circuit Diagram 1MRK 001	Terminal diagram 1MRK 001	Diagram
RAIDG 1	IN	x			006-BA	007-BA	007-BAA	On request
RAIDG 1	IN		x		006-CA	007-CA	007-CAA	On request
RAIDG 1	IN	x	x		006-DA	007-DA	007-DAA	On request
RAIDG 1	IN	x	x	x	006-EA	007-EA	007-EAA	Fig. 55, 56

**One-, two- or three phase directional overcurrent protection and/or
directional earth-fault protection with the measuring relay(s)
RXPDK 21H and/or RXPDK 22H and/or RXPDK 23H**

Type	Function	Test switch	DC-DC converter	Tripping relays	Ordering No. 1MRK 001	Circuit Diagram 1MRK 001	Terminal diagram 1MRK 001	Diagram
RAPDK 211	1I >		X		021-CB	022-CB	022-CBA	On request
RAPDK 211	1I >	X	X		021-DB	022-DB	022-DBA	On request
RAPDK 211	1I >	X	X	X	021-EB	022-EB	022-EBA	On request
RAPDK 212	2I >		X		021-HB	022-HB	022-HBA	On request
RAPDK 212	2I >	X	X		021-KB	022-KB	022-KBA	On request
RAPDK 212	2I >	X	X	X	021-LB	022-LB	022-LBA	On request
RAPDK 213	3I >		X		021-YC	022-YC	022-YCA	On request
RAPDK 213	3I >	X	X		021-PC	022-PC	022-PCA	On request
RAPDK 213	3I >	X	X	X	021-ZC	022-ZC	022-ZCA	On request
RAPDK 221	IN		X		061-CA	062-CA	062-CAA	On request
RAPDK 221	IN	X	X		061-DA	062-DA	062-DAA	On request
RAPDK 221	IN	X	X	X	061-EA	062-EA	062-EAA	On request
RAPDK 223	2I > + IN		X		061-YB	062-YB	062-YBA	On request
RAPDK 223	2I > + IN	X	X		061-PB	062-PB	062-PBA	On request
RAPDK 223	2I > + IN	X	X	X	061-ZB	062-ZB	062-ZBA	On request
RAPDK 224	3I > + IN	X	X		061-UB	062-UB	062-UBA	On request
RAPDK 224	3I > + IN	X	X	X	061-VB	062-VB	062-VBA	Fig. 57-59
RAPDK 231	IN		X		091-CA	092-CA	092-CAA	On request
RAPDK 231	IN	X	X		091-DA	092-DA	092-DAA	On request
RAPDK 231	IN	X	X	X	091-EA	092-EA	092-EAA	On request

RAPDK 2I > + IN 233			X			091-YB	092-YB	092-YBA	On request
RAPDK 2I > + IN 233	X		X			091-PB	092-PB	092-PBA	On request
RAPDK 2I > + IN 233	X		X	X		091-ZB	092-ZB	092-ZBA	On request
RAPDK 3I > + IN 234	X		X			091-UB	092-UB	092-UBA	On request
RAPDK 3I > + IN 234	X		X	X		091-VB	092-VB	092-VBA	Fig. 60, 62

Two- or three-phase overcurrent protection and directional or non-directional earth-fault protection with measuring relays RXIDK 2H and RXPDK 22H or RXIDG 21H

Type	Function	Test switch	DC-DC converter	Tripping relays	Ordering No. 1MRK 001	Circuit Diagram 1MRK 001	Terminal diagram 1MRK 001	Diagram
RACIK 2	1I > + IN	X			006-GA	007-GA	007-GAA	On request
RACIK 2	1I > + IN		X		006-HA	007-HA	007-HAA	On request
RACIK 2	1I > + IN	X	X		006-KA	007-KA	007-KAA	On request
RACIK 2	1I > + IN	X	X	X	006-LA	007-LA	007-LA	On request
RACIK 3	2I > + IN	X			006-SA	071-SA	071-SAA	On request
RACIK 3	2I > + IN		X		006-TA	071-TA	071-TAA	On request
RACIK 3	2I > + IN	X	X		006-UA	071-UA	071-UAA	On request
RACIK 3	2I > + IN	X	X	X	006-VA	071-VA	071-VAA	On request
RACIK 4	3I > + IN	X			006-NA	007-NA	007-NAA	On request
RACIK 4	3I > + IN		X		006-YA	007-YA	007-YAA	On request
RACIK 4	3I > + IN	X	X		006-PA	007-PA	007-PAA	On request
RACIK 4	3I > + IN	X	X	X	006-ZA	007-ZA	007-ZAA	Fig. 63, 64
RACIK 223	2I > + IN	X			070-NA	071-NA	071-NAA	On request
RACIK 223	2I > + IN		X		070-YA	071-YA	071-YAA	On request
RACIK 223	2I > + IN	X	X		070-PA	071-PA	071-PAA	On request
RACIK 223	2I > + IN	X	X	X	070-ZA	071-ZA	071-ZAA	On request
RACIK 224	3I > + IN		X		070-TA	071-TA	071-TAA	On request
RACIK 224	3I > + IN	X	X		070-UA	071-UA	071-UAA	On request
RACIK 224	3I > + IN	X	X	X	070-VA	071-VA	071-VAA	On request

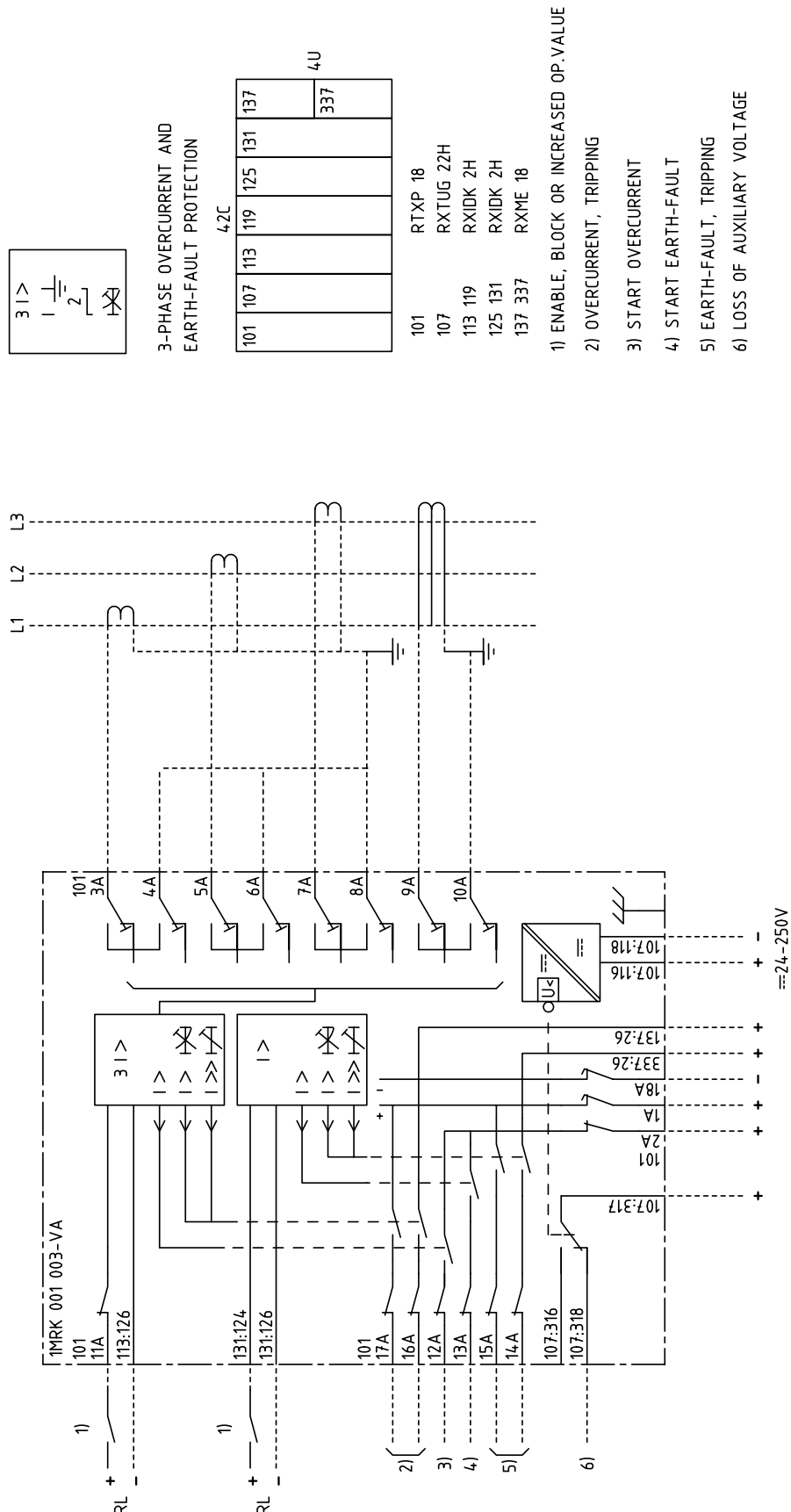

Fig. 54 Terminal diagram 1MRK 001 003-VAA

**RAIDK, RAIDG, RAPDK and
RACIK Phase overcurrent and
earth-fault protection assemblies
based on single phase measuring**

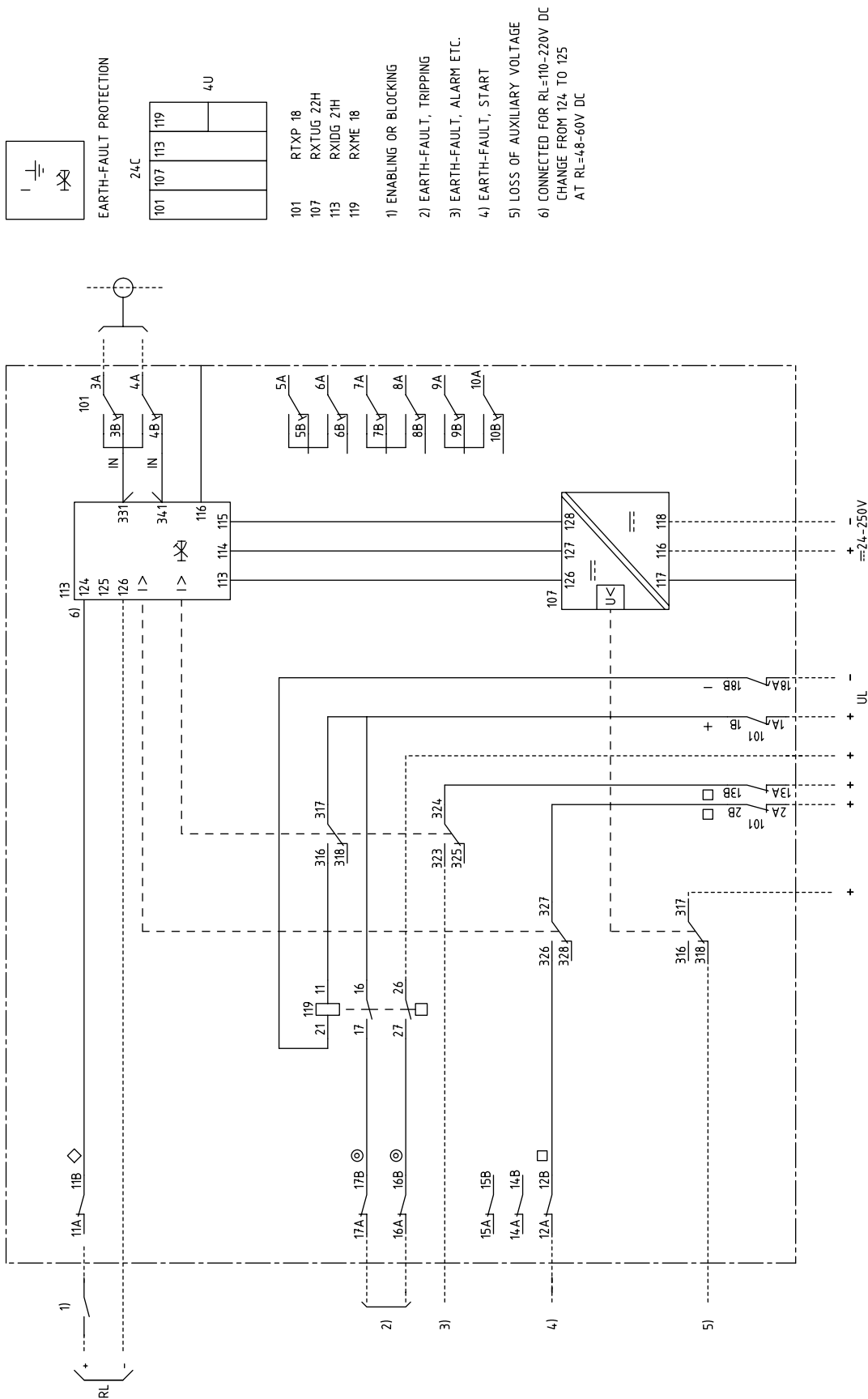

Fig. 55 Circuit diagram 1MRK 001 007-EA

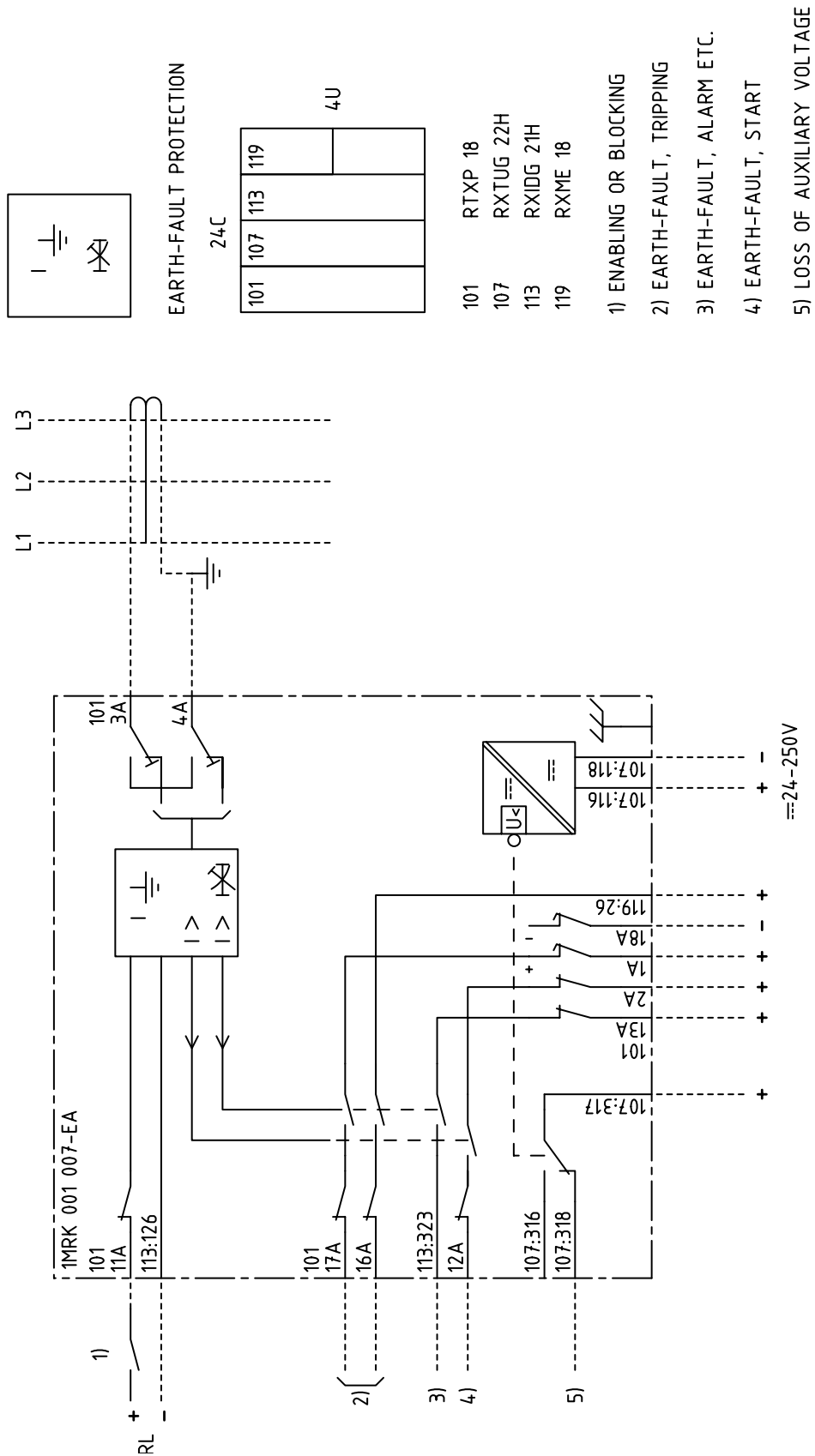

Fig. 56 Circuit diagram 1MRK 001 007-EAA

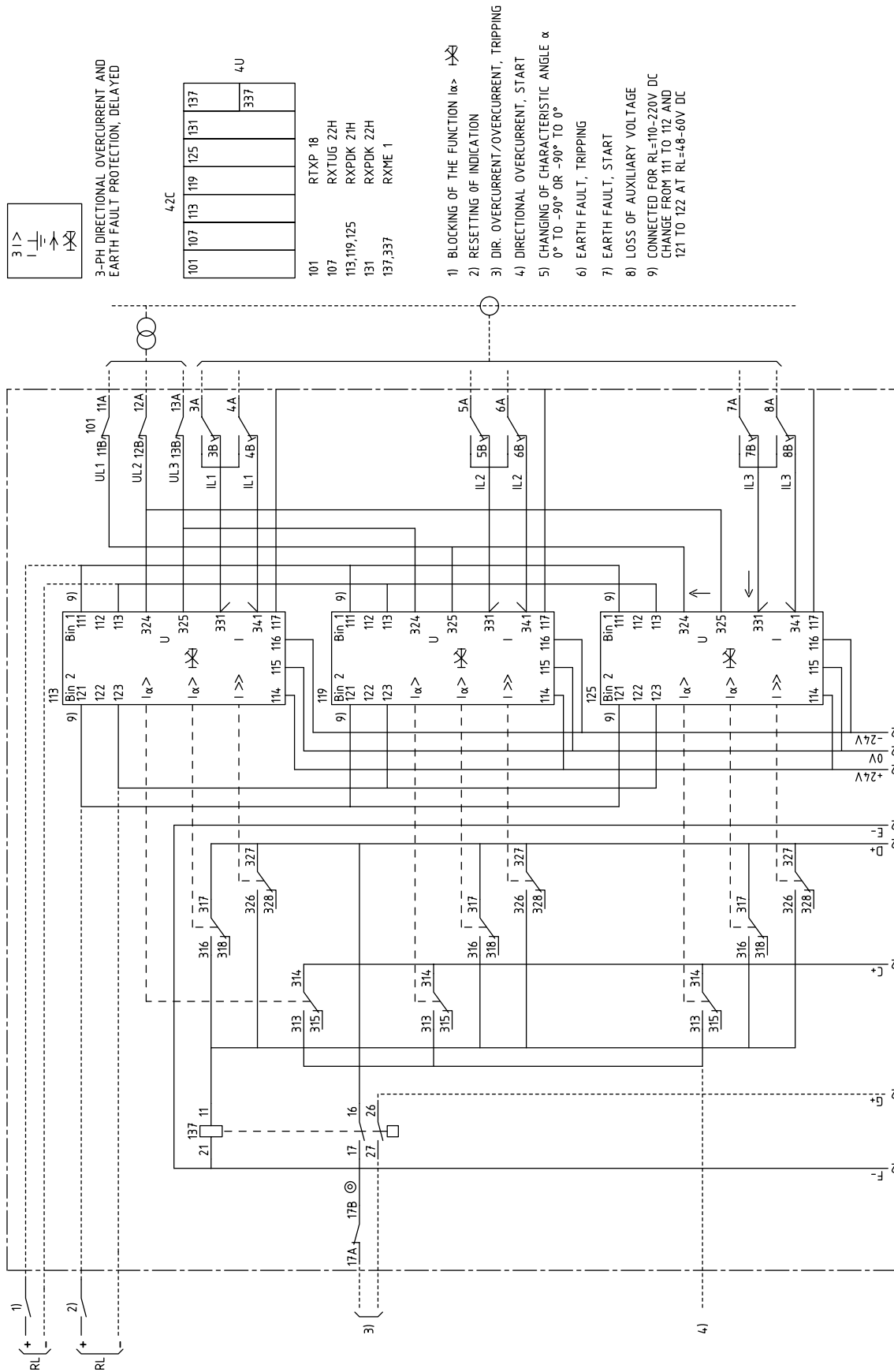

Fig. 57 Circuit diagram 1MRK 001 062-VB, Page 1

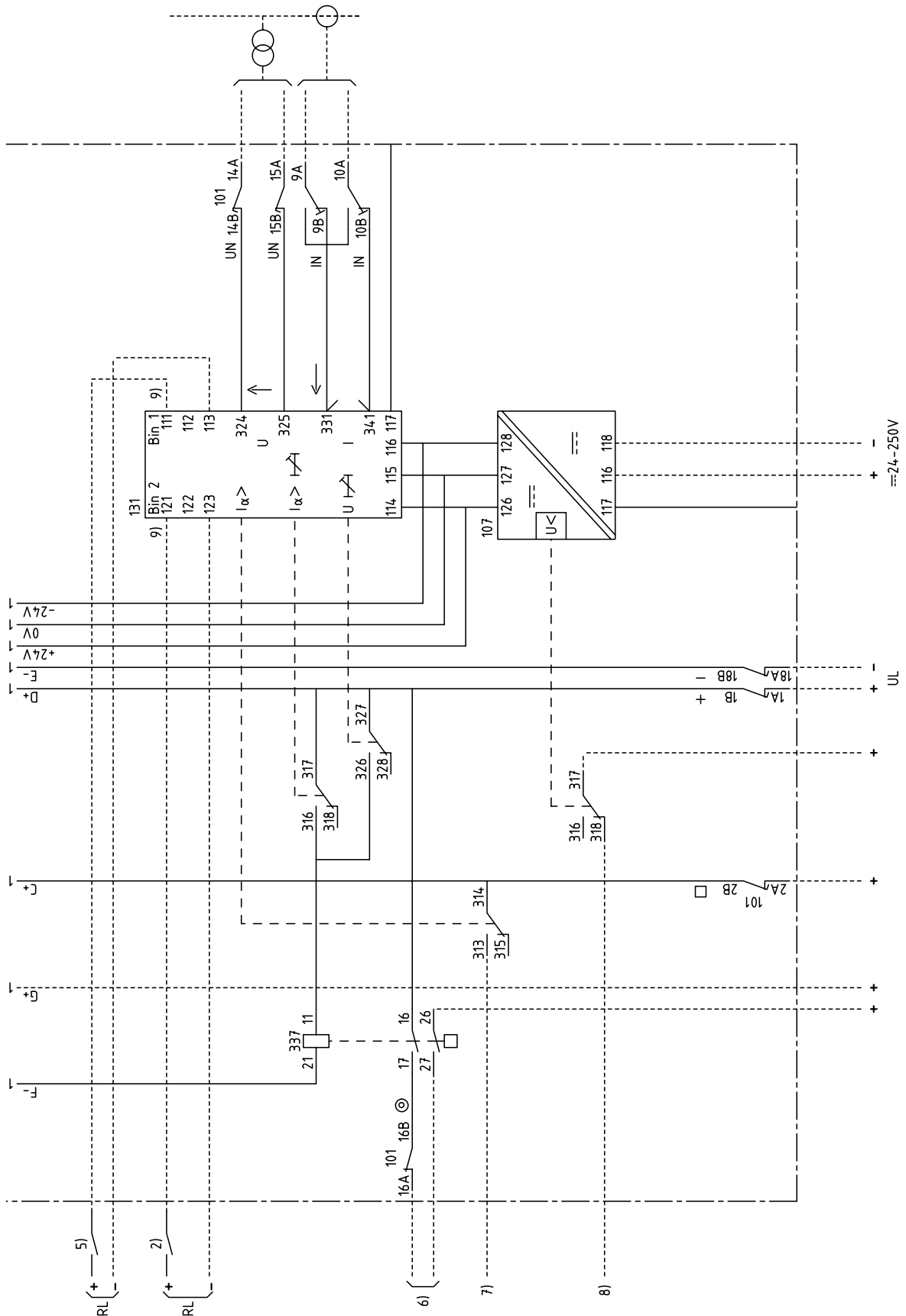

Fig. 58 Circuit diagram 1MRK 001 062-VB, Page 2

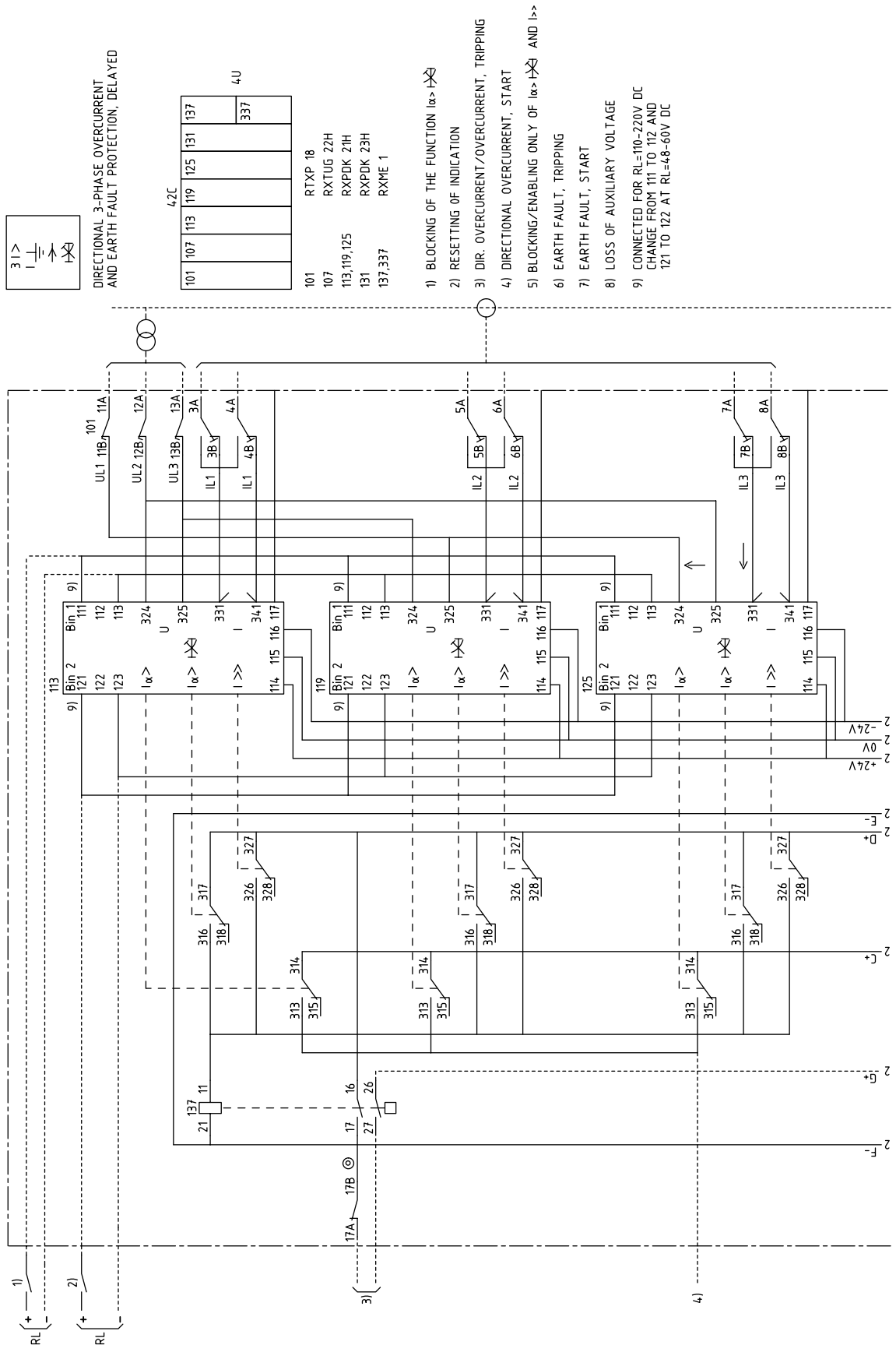

Fig. 60 Circuit diagram 1MRK 001 092-VB, Page 1

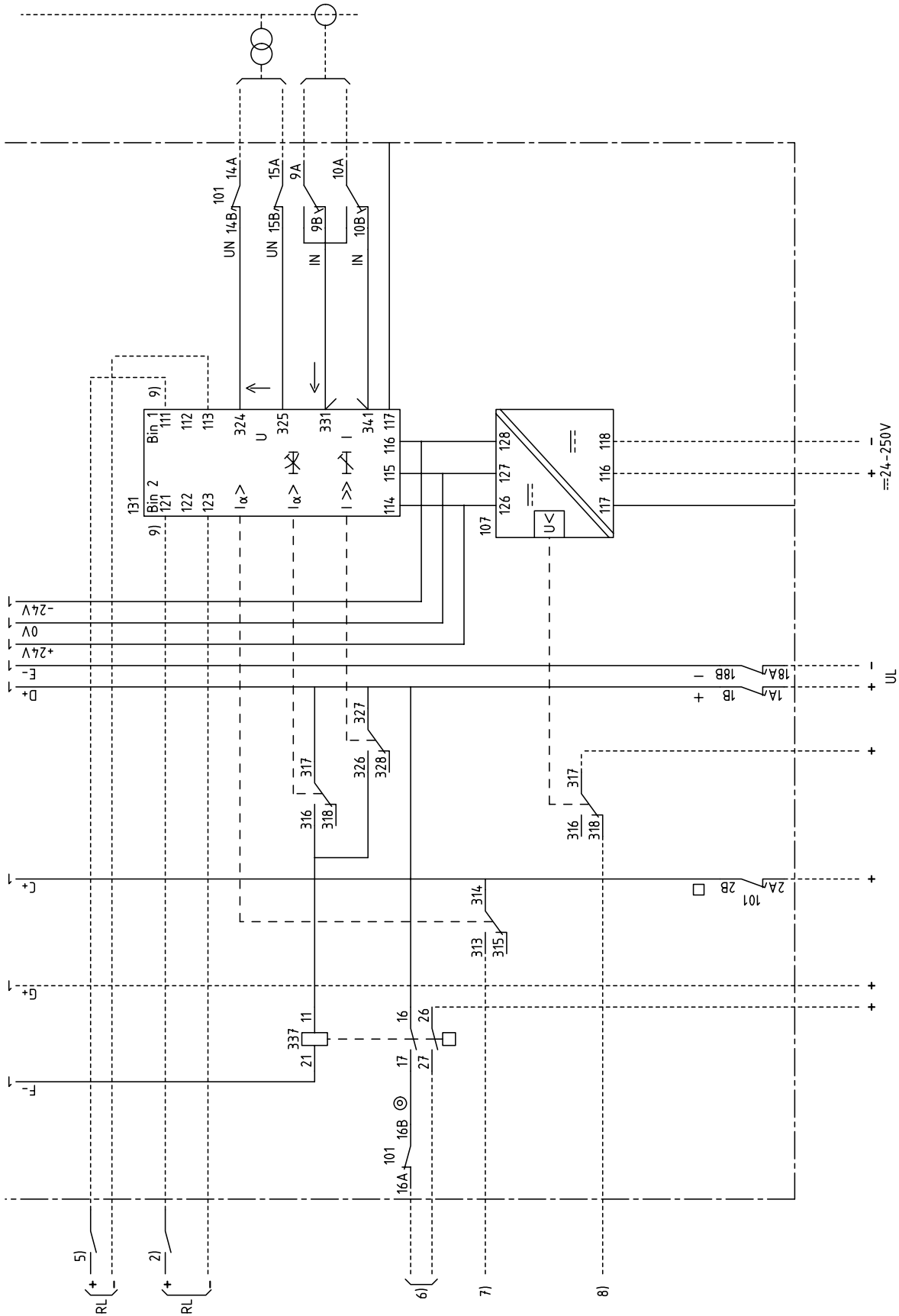

Fig. 61 Circuit diagram 1MRK 001 092-VB, Page 2

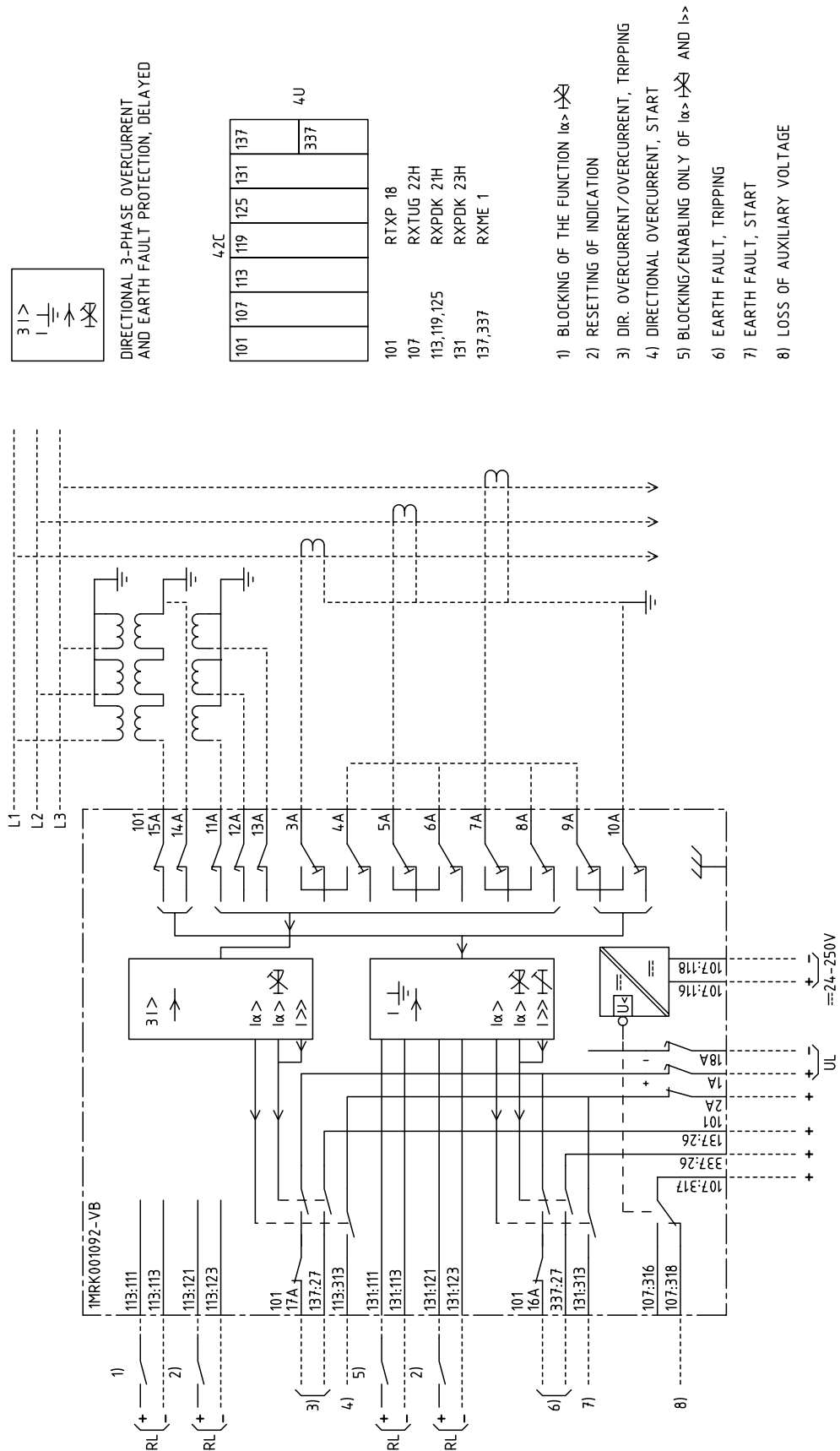

Fig. 62 Circuit diagram 1MRK 001 092-VBA

**RAIDK, RAIDG, RAPDK and
RACIK Phase overcurrent and
earth-fault protection assemblies
based on single phase measuring**

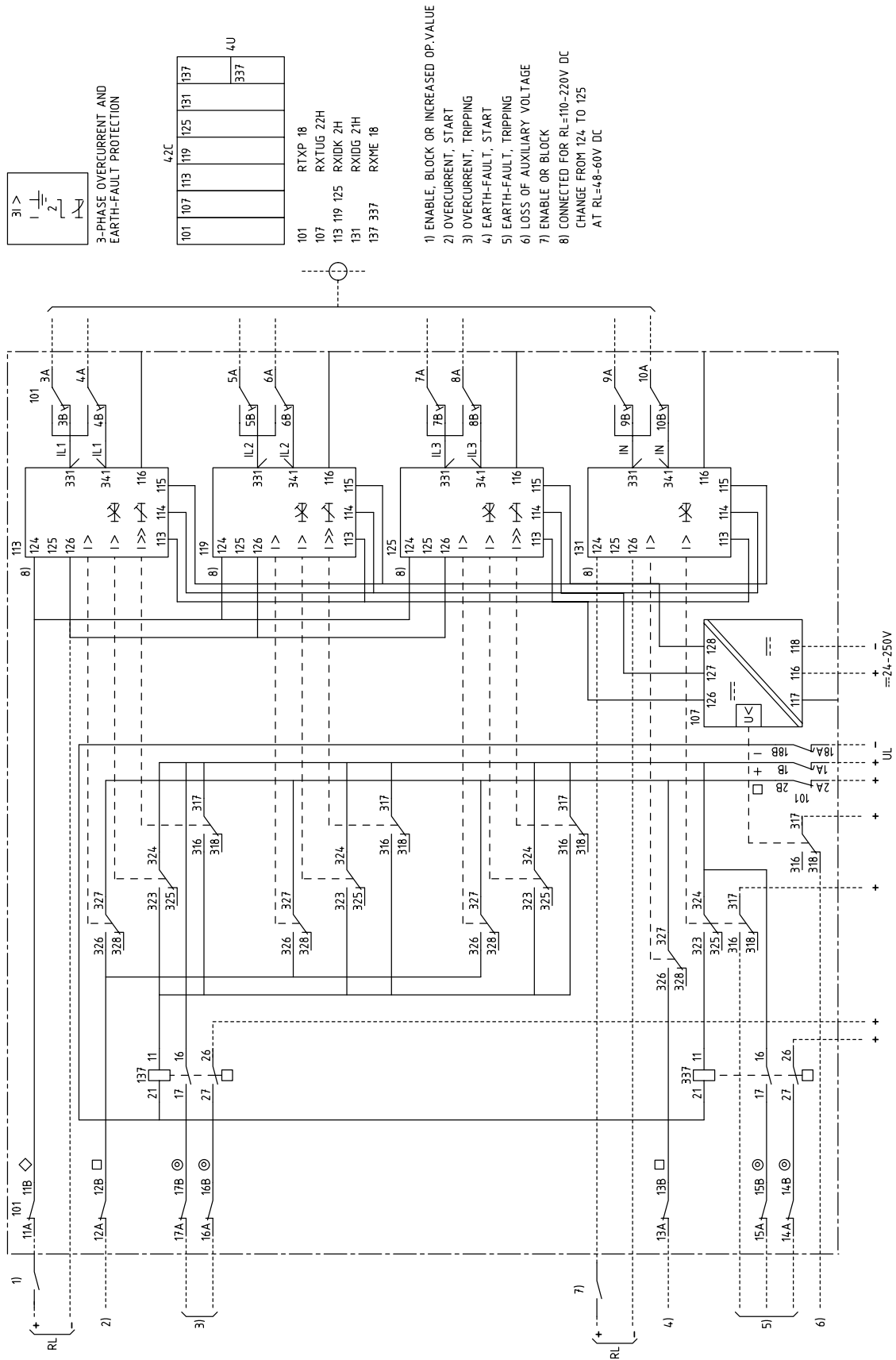

Fig. 63 Circuit diagram 1MRK 001 007-ZA

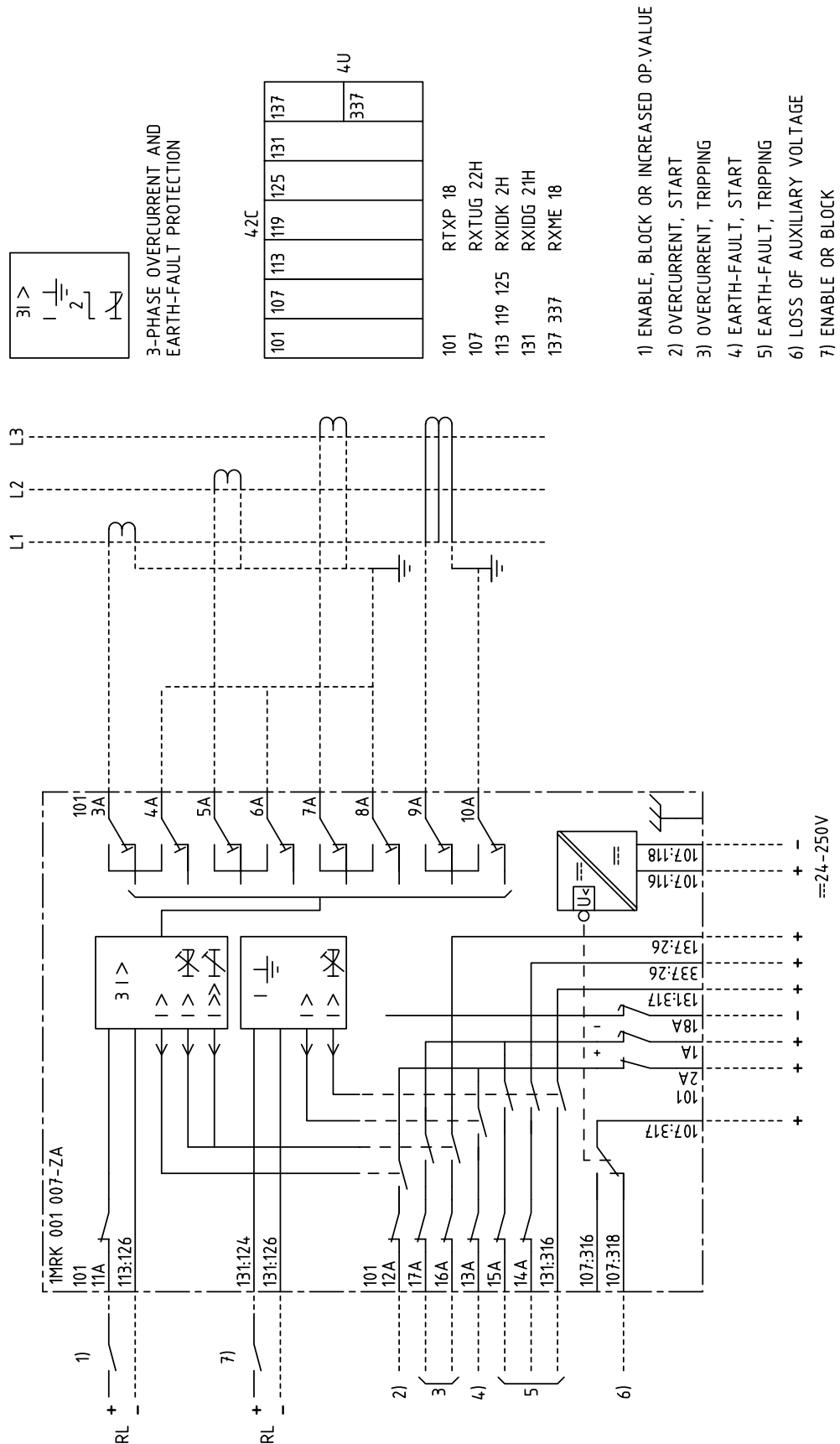

Fig. 64 Terminal diagram 1MRK 001 007-ZAA

ABB Automation Products AB

Substation Automation Division
S-721 59 Västerås
Sweden

Tel +46 21 342000
Fax +46 21 146918