



General

Over/underfrequency relays can be used for several power system protection and control applications. Two examples are underfrequency load shedding and power generation unit protection.

The COMBIFLEX[®] frequency protection RAFK meets the requirements for different kind of protection and control applications using frequency as input quantity. RAFK contains measuring relays RXFK 2H. The protection is available with two, four or six stages of operation. The different stages operate independently of each other. The relay can operate for over and under frequency. Also a df/dt (rate of change of frequency) function is available. The over/underfrequency function as well as the rate of change of frequency function, is highly independent of changes in voltage amplitude during disturbance events.

All RAFK protections are mounted in the COMBIFLEX[®] modularised system and are available with or without test switch, DC-DC converter or additional heavy duty tripping relay.

List of contents

1	Application.....	3
1.1	Frequency controlled load shedding	3
1.2	Protection of generating units	3
1.3	System wide protection	4
1.4	RAFK in the applications.....	4
2	Measurement principles	6
3	Design	9
3.1	Test switch	9
3.2	DC-DC converter	9
3.3	Measuring relay.....	9
3.4	Tripping relay.....	10
4	Setting and connection.....	11
4.1	Connection	12
4.2	Settings.....	13
4.3	Indication	15
4.4	Tripping and start outputs	15
4.5	ESD	15
5	Technical data for over/underfrequency relay RXFK 2H ...	16
6	Receiving, Handling and Storage	20
6.1	Receiving and Handling.....	20
6.2	Storage	20
7	Installation, Testing and Commissioning.....	21
7.1	Installation.....	21
7.2	Testing.....	24
7.3	Commissioning	26
8	Maintenance	27
9	Circuit and terminal diagrams	28

1 Application

1.1 Frequency controlled load shedding

Most power systems can withstand the loss of a single generating unit. During such “normal” disturbances the spinning active reserve, in the power system, is activated. The network frequency will be regulated back to an acceptable value. Simultaneous loss of several power system components, as a result of a more severe disturbance, may cause a severe deficit in active and reactive power. Such infrequent events may cause severe drop in system frequency. The spinning power reserve, in the power system, is normally not sufficient to restore acceptable network frequency, after such a severe disturbance. Other additional actions must be activated. Such activations are:

- Frequency controlled load shedding.
- Trip of load with low priority.
- Activation of HVDC emergency power. This is only of interest if the HVDC link is connected to another power system.

All these actions are normally initiated from detection of low frequency. An underfrequency relay can be used for this detection and initiations of different kinds of protective actions.

Frequency relays for HVDC emergency power activation, load shedding and power generator islanding must operate correctly even if the voltage magnitude decays rapidly at the same time as the system frequency decays.

1.2 Protection of generating units

Different types of power generating units have different capability to withstand network frequency, deviating from the normal frequency.

High frequency can be the consequence of unintentional disconnection of the generator from the grid and the primary mechanical power is not cut off. Another reason for high frequency can be separation of the power system where one part of the system, where the generator is connected, has a surplus of generation resulting in high network frequency in this network island.

Low frequency can be the consequence of separation of the power system where the part of the system, connecting the generator to be protected, has a lack of active power generation.

Hydro power plants are normally very robust with a capability to withstand significant frequency deviations. There are however events when the detection of overfrequency is essential in order to avoid damages on the generator and the turbine. This can be the case if the generator is unintentionally disconnected from the grid, without shutting down the hydro primary power. In case of overfrequency the mechanical primary power (hydro) must be forced down to zero as rapidly as possible.

Thermal power turbines must normally be operated within quite a narrow frequency band. In case of high or low frequency there is a risk of damages to the turbine, due to vibrations.

The cooling of the generator can be reduced in case of low network fre-

quency. Low frequency will also affect the excitation of the generator and the unit block transformer.

In the case of a severe power system disturbance there can be significant changes of the voltage and/or frequency. If there is a total or partial collapse of the system, it is of great value if the thermal generating units can transfer to household operation. This will enable a quick re-establishment of the power system, as the generating units can be producing power to the network without any long delay. If the generating unit fail to transfer to household operation, their starting time can be very long (several hours).

To enable the transition to household operation, during the event of a power system collapse, it is important to have a well coordinated frequency protection of the generating unit. This means that the unit shall be disconnected from the external network before the trip of equipment within the plant. At the same time it is of value to keep the generator connected to the system as long as possible to, if possible, avoid system collapse.

As we cannot predict the voltage and frequency during all possible events, we cannot guarantee that even a well coordinated protection will give successful transition to household operation. It is however of great importance to have frequency relays with good performance.

1.3 System wide protection

Modern communication schemes make it possible to make system wide protection, where measurement points in different locations of the power system are used. System wide protection schemes can be used for prevention of power system collapse due to transient instability, undamped oscillations, voltage instability, power imbalance, etc. In some of the schemes for system wide protection frequency relays or rate of change of frequency relays can be used.

1.4 RAFK in the applications

Since the requirements for frequency measurement functions differ depending on application range and needed accuracy for load shedding and generator islanding, two models exist.

The RXFK 2H (variant -AA) has two discrete frequency-measuring steps settable in the range of 5 Hz and 10 Hz off the rated frequency respectively. Each step can be set either as an over- or an under-frequency element. The second step can be set to measure absolute frequency or alternatively as a df/dt function. It is possible to set response to a negative df/dt or absolute rate of change, i.e. an output is then achieved for both increasing and decreasing frequency changes. It is also possible to control the response of the df/dt output contact via the first frequency step. The resolution for the two frequency levels of this model is 25 mHz. A df/dt setting range of 0,5 - 10 Hz/second is available in this model.

The RXFK 2H (variant -BA) also has two discrete frequency-measuring steps but settable in a more narrow range to yield a finer resolution, i.e. 10 mHz steps. The two ranges permit settings up to 4 Hz over or under rated frequency.

The start signal may be used as an instantaneous output when high speed is of the outmost essence. The normal trip-output may be delayed, with a setting range from 0 to 20 seconds.

Another feature is the total independence of the magnitude of input voltage level as long as the voltage remains within the defined range. As simultaneous changes in input voltage magnitude and frequency occur during system disturbances, this has been part of the type test procedure. The tests have shown that the accuracy of the relay is acceptable even with voltage changes up to 50% of the rated voltage/s. A sudden dip in voltage will not cause erratic frequency measurement since the measuring principle has been made independent of the absolute voltage level. To assure that the relay will not trip at a sudden dip in the voltage, the blocking voltage must be set larger than 25% of the maximum measuring voltage at normal operation. The undervoltage blocking can be set 10 - 80 V (100 V input) or 20 - 160 V (200 V input).

A major disturbance will lead to a very fast frequency and voltage drop. It is so rapid that the underfrequency load shedding system or the generator underfrequency islanding system must react instantaneously. Analysis supported by operational experience shows that a rate-of-change in local frequency in the order of 2 to 5 Hz/second must be considered. It is also necessary to consider a very large rate-of-change in voltage magnitude.

2 Measurement principles

The RXFK 2H, variants -AA and -BA, relays constitutes the measuring units of RAFK. The functional diagram in Fig. 1 and Fig. 3 illustrates the mode of operating. For setting of operate values, the functions of the output relays and the LEDs, see Section 4.

To provide a suitable voltage for the electronic measurement circuits the relays are provided with an input-transformer. The output-voltage of the transformer is scaled with dip-switched controlled transformer taps before it is filtered with a 4th order lowpass filter with a cut-off frequency equal to 180 Hz.

The filtered voltage is applied to the zero detector and a semi-cycle-time ($T/2$) is calculated in the microprocessor every zero-crossing.

The input voltage is also rectified before it is sampled with a sample rate of 1000 samples/s. The voltage ripple is then reduced with a moving average filter. This voltage is used for the under-voltage-block function. The under-voltage-block function disables the start stages when the voltage has decreased below U_s .

The frequency start units operates when $2/T_{[0]}$ and $2/T_{[-1]}$ has reached the set operate frequency for stage one or stage two. For stage two, frequency function or df/dt function can be selected (variant -AA only). For stage one only frequency function is available. The two stages are provided with definite-time trip delay.

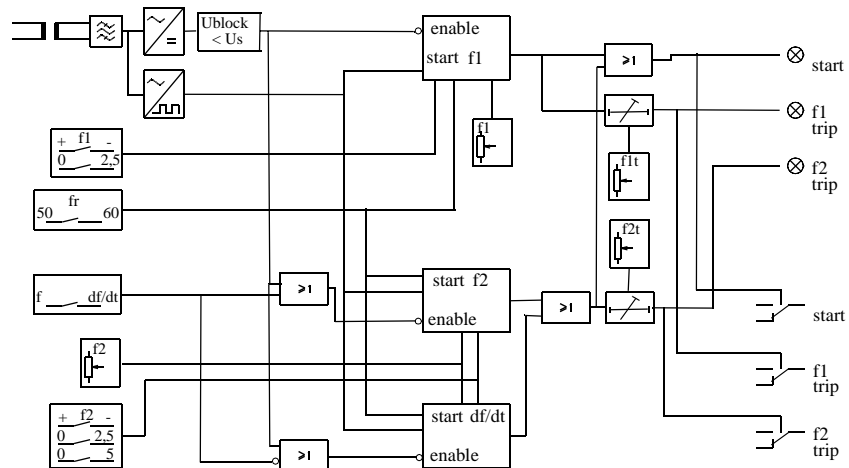

Fig. 1 Functional diagram illustrating the mode of operating of the RXFK 2H (variant -AA) relay

The df/dt unit operates for the rate-of-change of frequency according to Section 4. The df/dt value is the quotient between changed frequency and the correlated time-span. The time-span for which the df/dt is calculated on is accounted in Fig. 2, in steps of 25 mHz/s. The difference of frequency is calculated with frequency-values from the time where the time-

span started, up-to now. Every frequency value has been filtered with a four point moving average filter. The result from the calculation is then filtered with four point moving average filter. The start df/dt unit operates when the filtered value has reach the set operate value.

Setting range df/dt Hz/s (in steps of 25mHz/s)	Nr of cycles
0.2 - 0.45	14
0.475 - 0.95	12
0.975 - 1.45	10
1.475 - 1.95	8
1.975 - 2.95	6
2.975 - 3.95	4
3.975 - 10	2

Fig. 2 The measurement time for calculating the df/dt value

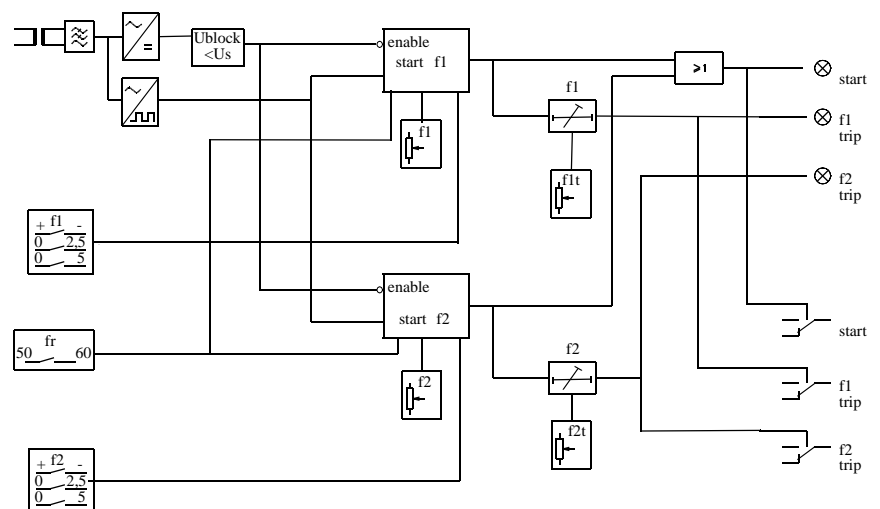

Fig. 3 Functional diagram illustrating the mode of operating of the RXFK 2H (variant -BA) relay

When the processor starts it executes a self test sequence. If the processor fails to start in a proper way the LEDs will indicate by flashing according to Fig. 4 or the "In serv." LED will not be lit. The program in the micro-processor is executed in a fixed loop with a constant looptime. The loop is supervised by an internal watch dog which initiates a program restart if the program malfunctions.

Test sequence:	Test error indication:
Config registers	All LED's flash in clockwise rotation
RAM	"Trip f1" flashes
ROM	"Trip f2" flashes
A/D	"Trip f1" and "Trip f2" flash

Fig. 4 Self test error indication of the RXFK 2H relays

The reset button has two functions, LED check and resetting the LEDs. When the button is depressed, the "Start", "Trip f1" and "Trip f2" LEDs are lit and the "In serv." LED is switched off, in order to check the LEDs. When the button is released the "Start", "Trip f1" and "Trip f2" LEDs are reset to show the actual status and "In serv" LED is relit.

The binary input, which can be used for remote resetting of the "Trip f1" and "Trip f2" LEDs, is galvanically separated from the electronic measurement circuits with an opto-coupler.

The frequency dependence and the influence of harmonics for the frequency and df/dt functions are shown in Section 5.

3 Design

The over/under frequency protection type RAFK is designed in a number of variants with up to six frequency stages for single-phase application. Each protection is available with or without test switch RTXP 18, DC-DC converter RXTUG 22H or tripping relay RXSF 1.

All the protections are built up by modules in the COMBIFLEX[®] modular system mounted on apparatus bars. The connections to the protections are done by COMBIFLEX[®] socket equipped leads.

The type of modules and their physical position and the modular size of the protection are shown in the *Buyer's Guide* and in the Circuit Diagram of respective protection. The following modules can be included.

3.1 Test switch

The test switch RTXP 18 is a part of the COMBITEST testing system described in the *Buyer's Guide*, Document No. 1MRK 512 001-BEN. A complete secondary testing of the protection can be performed by using a test-plug handle RTXP 18 connected to a test set. When the test-plug handle is inserted into the test switch, preparations for testing are automatically carried out in a proper sequence, i.e. blocking of tripping circuits, short-circuiting of current circuits, opening of voltage circuits and making the protection terminals available for secondary testing. RTXP 18 has the modular dimensions 4U 6C.

All input voltages can be measured from the test-plug or from the current measuring plug RTX M connected to a voltmeter. The tripping circuits can be blocked by a trip-block plug RTX B and the protection can be totally blocked by a block-plug handle RTX F 18.

3.2 DC-DC converter

The DC-DC converter RXTUG 22H converts the applied battery voltage to an alternating voltage which is then transformed, rectified, smoothed and in this application regulated to ± 24 V DC. The auxiliary voltage is in that way adopted to the measuring relays. In addition, the input and output voltages will be galvanically separated, which contributes to damping of possible transients in the auxiliary voltage supply to the measuring relays. The converter has a built-in signal relay and a green LED for supervision of the output voltage.

RXTUG 22H has the modular dimensions 4U 6C. It is described in the *Buyer's Guide*, Document No. 1MRK 513 001-BEN.

3.3 Measuring relay

The time-over/under frequency relays RXFK 2H are static, microprocessor based relays with two delayed frequency stages f1 and f2. The relay consists mainly of an input transformer for voltage adoption and isolation, filter circuits, digital-analog converter, microprocessor, MMI consisting of a programming switch and potentiometers for setting, and LEDs for start, trip and in service indications, and three output relays, each with a change-over contact. The output relays operate for start of stage 1 or

stage 2, for delayed operation of stage 1 and for delayed operation of stage 2 respectively. The relay has also a binary input for remote resetting of the LED indications.

The relays can be connected for two rated voltages. There are two variants of the relays with the frequency setting steps 10 mHz and 25 mHz respectively. Operate values of the stages f1 and f2 are set by potentiometers and programming switches in the front.

The two frequency stages can be programmed for over- or under frequency measuring and be definite-time delayed independent of each other. In RXFK 2H, variant -AA (25 mHz), the stage f2 can be programmed for measuring the rate of change of the frequency.

3.4 Tripping relay

The signal relay RXSF 1 is used as tripping relay. It consists of two electromechanical relays, each with three medium-duty make contacts and a red flag. The flag will be visible when the armature picks-up and is manually reset by a knob in the front of the relay. Typical operate time is 20-25 ms.

RXSF 1 has the modular dimensions 2U 6C. The relay is described in the *Buyer's Guide*, Document No. 1MRK 508 015-BEN.

4 Setting and connection

Variante -AA

Rated voltage of the relay U_r (100/200 V)

LED indicators:

In serv. (green): indicates relay in service.

Start (yellow): indicates operation of f1/f2 (no time delay).

Trip f1 (red): indicates operation of f1 after the set time delay.

Trip f2 (red): indicates operation of f2 after the set time delay.

f1:

Potentiometer (P1) for setting of the operate value for the function f1.

Potentiometer (P2) for setting of the definite time delay for the function f1.

10-pole programming switch (S1) for setting of the voltage U_s , rated frequency, setting constants k , over-/underfrequency function (f1) and over-/underfrequency alternatively rate of change of frequency (f2).

f2:

Potentiometer (P3) for setting of the operate value for the function f2.

Potentiometer (P4) for setting of the definite time-delay for the function f2.

Reset push-button.

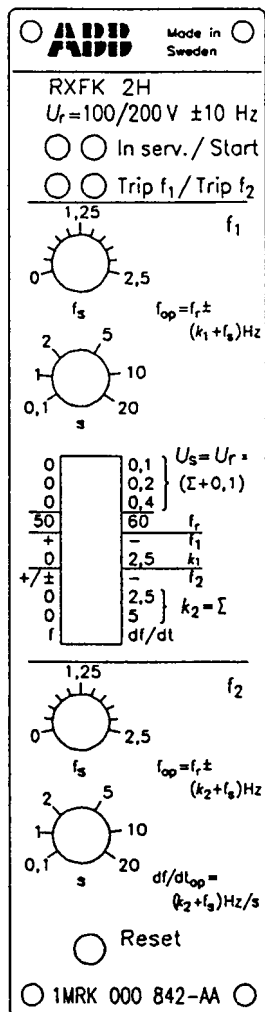

1MRK 000 117-35

Fig. 5 Front layout variante -AA

Variant -BA

Rated voltage of the relay U_r (100/200 V)

LED indicators:

In serv. (green): indicates relay in service.

Start (yellow): indicates operation of f_1/f_2 (no time delay).

Trip f_1 (red): indicates operation of f_1 after the set time delay.

Trip f_2 (red): indicates operation of f_2 after the set time delay.

f_1 :

Potentiometer (P1) for setting of the operate value for the function f_1 .

Potentiometer (P2) for setting of the definite time delay for the function f_1 .

10-pole programming switch (S1) for setting of the voltage U_s , rated frequency, setting constants k and over-/underfrequency function.

f_2 :

Potentiometer (P3) for setting of the operate value for the function f_2 .

Potentiometer (P4) for setting of the definite time-delay for the function f_2 .

Reset push-button

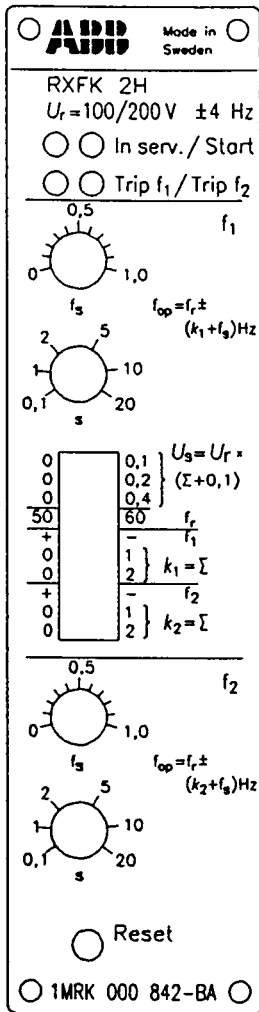

1MRK 000 117-34

Fig. 6 Front layout variant -BA

4.1 Connection

The RXFK 2H relay requires a dc-dc converter type RXTUG for auxiliary supply ± 24 V. Connection of voltage RL shall be made only when the binary input is used.

Observe that the relay has two rated voltages U_r (100 or 200 V) depending on if the voltage is connected to 324-325 (low) or 323-325 (high).

NOTE! The auxiliary voltage supply should be interrupted or the output circuits should be blocked to avoid the risk of unwanted alarm or tripping, before the relay is plugged into or withdrawn from its terminal base.

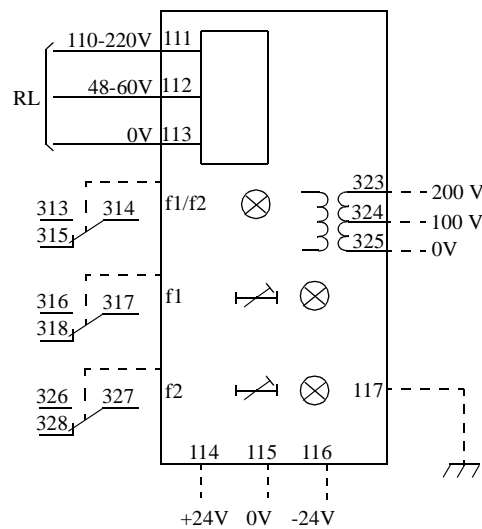

Fig. 7 Terminal diagram

4.2 Settings

All settings can be changed while the relay is in normal service.

Variant -AA

1. Setting of the voltage U_s .

The frequency measurement function is blocked when the voltage is less than the set voltage. **Note! To avoid misoperation at a sudden voltage drop, the setting voltage U_s must not be smaller than 25% of the maximum voltage at normal operation.** U_s is common for both stages f1 and f2, and is set with the programming switches S1:1, S1:2 and S1:3. The setting range is from 0,1 to 0,8 times the rated voltage U_r ($U_r = 100$ or 200 V).

2 Setting of the rated frequency f_r .

Set the rated frequency, 50 or 60 Hz, with the programming switch S1:4.

3. Setting of the operate value for f1.

Set the over- or underfrequency function (+ or -) with programming switch S1:5. The operation value is set according to the formula $f_{op} = f_r \pm (k_1 + f_s)$ Hz, where the constant k_1 is set to 0 or 2,5 Hz with the programming switch S1:6. f_s is settable between 0 - 2,5 Hz with potentiometer P1. The total setting range is ± 5 Hz.

4. The time delay for f1.

The time delay is definite-time and can be set between 0,1 - 20 s with potentiometer P2.

5. Setting of the operate mode and value for f2

f2 can be set for either pick-up function (f) or rate-of-change of frequency (df/dt) with the programming switch S1:10.

Setting of pick-up function (f):

Set over- or underfrequency function (+ or -) with programming switch S1:7. Operating value is set according to the formula $f_{op} = f_r \pm (k_2 + f_s)$ Hz, where the constant k_2 is set 0 - 7,5 Hz with the programming switches S1:8 and S1:9, and f_s is settable 0 - 2,5 Hz with potentiometer P3. The total setting range is ± 10 Hz.

Setting of rate-of-change of frequency (df/dt):

The function is set for absolute (\pm) or negative (-) rate-of-change with the programming switch S1:7. Operating value is set according to the formula $df/dt_{op} = (k_2 + f_s)$ Hz/s, where the constant k_2 is set 0 - 7,5 Hz/s with the programming switches S1:8 and S1:9, and f_s is settable 0 - 2,5 Hz/s with potentiometer P3. The minimum df/dt-setting is 0,5 Hz/s, and the total setting range is 0,5 - 10 Hz/s.

6. The time delay for f2.

The time delay is definite-time and can be set between 0,1 - 20 s with potentiometer P4.

7. The binary input.

The binary input is used for remote reset of the LED indicators. The function is activated when a voltage RL is applied to the binary input.

Variant -BA

1. Setting of the scale-constant U_s .

The frequency measurement function is released when the voltage is equal to or higher than the set value. **Note! To avoid misoperation at a sudden voltage drop, the setting voltage U_s must not be smaller than 25% of the maximum voltage at normal operation.** U_s is common for both stages f1 and f2, and is set with the programming switches S1:1, S1:2 and S1:3. The setting range is from 0,1 to 0,8 times the rated voltage U_r ($U_r = 100$ or 200 V)

2 Setting of the rated frequency f_r .

Set the rated frequency, 50 or 60 Hz, with the programming switch S1:4.

3. Setting of the operate value for f1.

Set the over- or underfrequency function (+ or -) with programming switch S1:5. The operating value is set according to the formula $f_{op} = f_r \pm (k_1 + f_s)$ Hz, where the constant k_1 is set between 0 to 3 Hz with the programming switches S1:6 and S1:7. f_s is settable between 0 - 1,0 Hz with potentiometer P1. The total setting range is ± 4 Hz.

4. The time delay for f1.

The time delay is definite-time and can be set between 0,1 - 20 s with potentiometer P2.

5. Setting of the operate value for f2

Set the over- or underfrequency function (+ or -) with programming switch S1:8. The operating value is set according to the formula $f_{op} = f_r \pm (k_2 + f_s)$ Hz, where the constant k_2 is set between 0 to 3 Hz with the programming switches S1:9 and S1:10. f_s is settable between 0 - 1,0 Hz with potentiometer P3. The total setting range is ± 4 Hz.

6. The time delay for f2.

The time delay is definite-time and can be set between 0,1 - 20 s with potentiometer P4.

7. The binary input.

The binary input is used for remote reset of the LED indicators. The function is activated when a voltage RL is applied to the binary input.

4.3 Indication

There are four LED indicators. The trip indicators seal-in and are reset manually by the "Reset" push-button or electrically via the binary input, while the start indicator resets automatically when the relay resets.

When the "Reset" push-button is depressed during normal operating conditions, all LEDs except "In serv." will light up.

When connecting RXFK 2H to the supply voltage, the relay performs a self test. The "In serv." LED is alight, after performing the self test and when the relay is ready for operation. In case of a fault, the LEDs will start flashing.

4.4 Tripping and start outputs

The RXFK 2H relay has one common start output for f1/f2, one tripping output for f1, and one tripping output for f2. Each output is provided with one change-over contact. All outputs reset automatically when the frequency goes to a value below the resetting value of the relay.

4.5 ESD

The relay contains electronic circuits which can be damaged if exposed to static electricity. Always avoid to touch the circuit board when the relay cover is removed during the setting procedure.

5 Technical data for over/underfrequency relay RXFK 2H

Voltage input

Rated voltage U_r	100/200 V
Set voltage U_s (blocking)	$(0,1-0,8) \times U_r$ (in steps of 0,1)
Setting range U_s $U_r = 100$ V	10-80 V in step of 10 V
Setting range U_s $U_r = 200$ V	20-160 V in step of 20 V
Effective voltage range U	$(1-4) \times U_s$
Voltage block	$U < U_s$
Rated frequency f_r	50/60 Hz
Operate frequency range	40-70 Hz
Power consumption at $U_r = 100$ V $U = \text{lowest } U_s$ $U = \text{highest } U_s$	2 mVA 210 mVA
Overload capacity continuously during 10 s	$3,5 \times U_r$ (Max. 500 V AC for COMBIFLEX) $4,0 \times U_r$ (Max. 500 V AC for COMBIFLEX)

Start function (Variant -AA)

Frequency function	Stage f_1 and f_2 (Frequency measuring)	Stage f_2 df/dt (Rate-of-change of frequency)
Setting range	$f_1 = 45-55$ Hz alt. $55-65$ Hz $f_2 = 40-60$ Hz alt. $50-70$ Hz	$ 0,5-10 $ Hz/s alt. $-(0,5-10)$ Hz/s
Measuring mode	Over or under frequency	Abs. or negative df/dt
Operate time at 50 Hz (typical) Hz = 0 \Rightarrow 1,001 x operate value Hz = 0,99 \Rightarrow 1,001 x operate value Operate time at 50 and 60 Hz at a simultaneous change of voltage and frequency. Start frequency 50 Hz (typical) Hz/s = 0 \Rightarrow 1,10 x operate value Hz/s = 0 \Rightarrow 1,50 x operate value	Start function 1045 ms (Voltage block for 1 s) 55 ms 35-80 ms Independent of voltage level	Start function df/dt set to: 0,5 Hz/s 1,0 Hz/s 310 ms 285 ms 245 ms 230 ms
Consistency of operate value	< 10 mHz	0,5 Hz/s < 5% 1,0 Hz/s < 3% 5,0 Hz/s < 3% 10 Hz/s < 2%
Reset value	70-100 mHz lower or higher than the set operate value (over/under)	
Harmonics: 100 / 120 Hz, 20% 150 / 180 Hz, 20% 250 / 300 Hz, 20%	No influence on the operate value No influence on the operate value No influence on the operate value	

Trip function (Variant -AA)

Frequency function	Stage f_1 and f_2 (Frequency measuring)
Time-delay	Definite time
Setting range	$t = (0)-20$ s
Accuracy at 50 Hz	1% and ± 10 ms
Reset time at 50 Hz (typical) Hz = 1,05 \Rightarrow 0,99 x operate value	55 ms

Trip function (Variant -AA, df/dt)

Frequency function	Stage f ₂ df/dt (Rate-of-change of frequency)		
Time-delay	Definite time		
Setting range	t = (0) to 20 s		
Start frequency 50 Hz	t = (0) (typical) df/dt set to: 1,0 Hz/s 285 ms 230 ms	t = 2 to 20 s df/dt set to: 0,5 Hz/s ±(1%+40 ms) ±(1%+20 ms)	1,0 Hz/s ±(1%+30 ms) ±(1%+20 ms)
Reset time	df/dt set to: 1,0 Hz/s 220 ms	df/dt set to: 0,5 Hz/s 235 ms	1,0 Hz/s 220 ms
Start frequency 50 Hz	Hz/s = 0 ⇒ 1,10 x operate value Hz/s = 0 ⇒ 1,50 x operate value		
Hz/s = 1,05 ⇒ 0 x operate value			

Start function (Variant -BA)

Frequency function	Stage f ₁ and f ₂ (Frequency measuring)
Setting range	f ₁ and f ₂ = 46-54 Hz alt. 56-64 Hz
Frequency measuring	Over or under frequency
Operate time at 50 Hz (typical) Hz = 0 ⇒ 1,001 x operate value Hz = 0,99 ⇒ 1,001 x operate value Operate time at 50 and 60 Hz at a simultaneous change of voltage and frequency.	Start function 1035 ms (Voltage block for 1 s) 70 ms 50 - 90 ms, Independent of voltage level
Consistency of operate value	< 10 mHz
Reset value	80-100 mHz lower or higher than the set operate value (over/under)
Harmonics: 100 / 120 Hz, 20% 150 / 180 Hz, 20% 250 / 300 Hz, 20%	No influence on the operate value No influence on the operate value No influence on the operate value

Trip function (Variant -BA)

Frequency function	Stage f ₁ and f ₂ (Frequency measuring)
Time-delay	Definite time
Setting range	t = (0)-20 s
Accuracy at 50 Hz	± (1%+10 ms)
Reset time at 50 Hz (typical) Hz = 1,05 ⇒ 0,99 x operate value	70 ms

Auxiliary DC voltage supply

Auxiliary voltage EL for RXTUG 22H Auxiliary voltage to the relay	24-250 V DC, ±20% ±24 V (from RXTUG 22H)
Power consumption at RXTUG 22H input 24-250 V before operation after operation without RXTUG 22H ±24 V before operation after operation	Max. 5,5 W Max. 6,5 W Max. 2,0 W Max. 3,0 W

Binary input

Binary input voltage RL	48-60 V and 110-220 V DC, -20% to +10%
Power consumption 48-60 V 110-220 V	Max. 0,3 W Max. 1,5 W

Output relays

Contacts		3 change-over
Maximum system voltage		250 V AC / DC.
Current carrying capacity	continuous during 1 s	5 A 15 A
Making capacity at inductive load with L/R >10 ms	during 200 ms during 1 s	30 A 10 A
Breaking capacity	AC, max. 250 V, $\cos \varphi > 0,4$ DC, with L/R < 40 ms	8 A 1 A 0,4 A 0,2 A 0,15 A
	48 V 110 V 220 V 250 V	

Electromagnetic compatibility (EMC), immunity tests

All tests are done together with the DC/DC-converter, RXTUG 22H

Test	Severity	Standard
Surge	1 and 2 kV, normal service 2 and 4 kV, destructive test	IEC 61000-4-5, class 3 IEC 61000-4-5, class 4
AC injection	500 V, AC	SS 436 15 03, PL 4
Power frequency magnetic field	1000 A/m	IEC 61000-4-8
1 MHz burst	2,5 kV	IEC 60255-22-1, class 3
Spark	4-8 kV	SS 436 15 03, PL 4
Fast transient	4 kV	IEC 60255-22-4, class 4
Electrostatic discharge In normal service with cover on	8 kv (contact) 15 kv (air) 8 kv, indirect application	IEC 60255-22-2, class 4 IEC 60255-22-2, class 4 IEC 61000-4-2, class 4
Radiated electromagnetic field	10 V/m, 26-1000 MHz	IEC 61000-4-3, Level 3
Conducted electromagnetic	10 V, 0,15-80 MHz	IEC 61000-4-3, Level 3
Interruptions in auxiliary voltage 110 V DC, no resetting for interruptions	2-200 ms < 40 ms	IEC 60255-11

Electromagnetic compatibility (EMC), emission tests

Test	Severity	Standard
Conducted	0,15-30 MHz, class A	EN 50081- 2
Radiated	30-1000 MHz, class A	EN 50081- 2

Insulation tests

Test	Severity	Standard
Dielectric Circuit to circuit and circuit to earth Over open contact	2,0 kV AC, 1 min 1,0 kV AC, 1 min	IEC 60255-5
Impulse voltage	5 kV, 1,2/50 μ s, 0,5 J	IEC 60255-5
Insulation resistance	> 100 M Ω at 500 V DC	IEC 60255-5

Mechanical tests

Test	Severity	Standard
Vibration	Response: 2,0 g, 10-150-10 Hz Endurance: 1,0 g, 10-150-10 Hz, 20 sweeps	IEC 60255-21-1, class 2 IEC 60255-21-1, class 1
Shock	Response: 5 g, 11 ms, 3 pulses Withstand: 15 g, 11 ms, 3 pulses	IEC 60255-21-2, class 1
Bump	Withstand: 10 g, 16 ms, 1000 pulses	IEC 60255-21-2, class 1
Seismic	X axis: 3,0 g, 1-35-1 Hz Y axis: 3,0 g, 1-35-1 Hz Z axis: 2,0 g, 1-35-1 Hz	IEC 60255-21-3, class 2, extended (Method A)

Temperature range

Storage	-20 °C to +70 °C
Permitted temperature range	-5 °C to +55 °C

Weight and dimensions

Equipment	Weight	Height	Width
RXFK 2H without RXTUG 22H	0,7 kg	4U	6C

6 Receiving, Handling and Storage

6.1 Receiving and Handling

Remove the protection package from the transport case and make a visual inspection for transport damages. Check that all screws are firmly tightened and all relay elements are securely fastened.

Check that all units are included in accordance with the apparatus list.

Normal ESD (Electrostatic Discharge) precautions for microprocessor relays should be observed when handling the relays.

6.2 Storage

If the protection package is to be stored before installation, this must be done in a dry and dust-free place, preferably in the original transport case.

Equipment frames and relay cases.

Detailed information on the COMBIFLEX® connection and installation components is given in Catalogue 1MRK 513 003-BEN. Information on the relay mounting system is given in Catalogue 1MRK 514 001-BEN.

RHGS 30

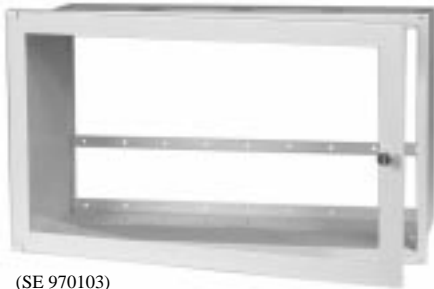

(SE 970103)

Fig. 9RHGS case

**RHGS cases for 19" cubicle mounting
or surface
mounting**

This type of case can be used for all common ways of mounting. The RHGS cases are available in three different sizes, which can be combined with mounting accessories to get maximum flexibility. The cases can also be combined together with the protections in the 500 range.

RHGX 8



(SE 81702)

Fig. 10RHGX case

**RHGX cases for flush- or semi-flush
panel mounting**

The RHGX cases are available in five sizes. The case, a metal box open at the back, has a flange (with a rubber sealing strip) at the front which acts as a stop when the case is inserted into a front panel opening. At the front of the case there is a door with a window and a rub-

Size: 4U 19"



(SE 96399)

Fig. 1119" equipment frame

19" equipment frames

These types of equipment frames are used for cubicle mounting or panel mounting of plug-in units in the COMBIFLEX® range. The frames are available in 3 sizes:

4U (17" x 19")

8U (14" x 19")

12U (21" x 19")

for mounting 20, 40 and 60 module seats respectively.

Connections

The external connections (dotted lines on the terminal and circuit diagrams) are made with leads with 20 A COMBIFLEX® sockets to the RTXP 18 test switch and with 10 A sockets to the relay terminal bases.

Each unit in the protection assembly has a unique item designation. The item designations are based on a coordinate system of U and C modules, where the first figure stands for the U-module position starting from the left-hand side - seen from the front side of the protection assembly - and the next two figures stand for the C-module position, starting from the top. The RTXP test switch in Fig. 12 has item designation 101, where the first figure stands for the U-module position and the next two figures stand for the C-module designation.

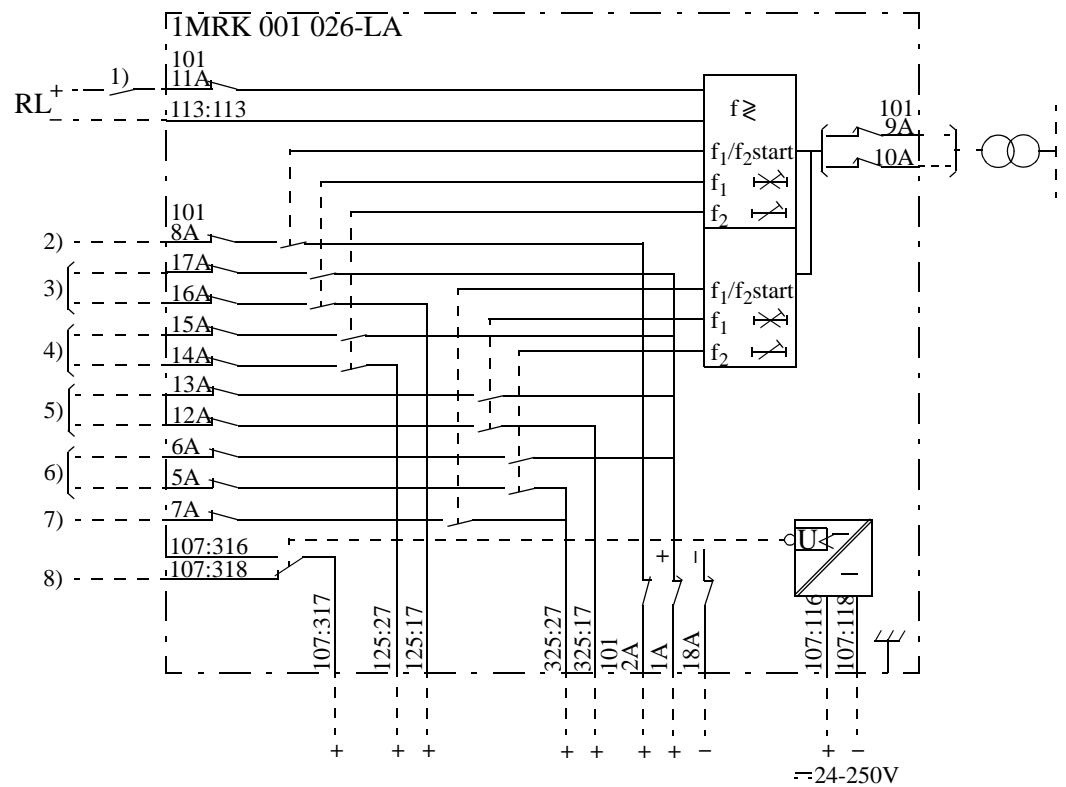

- | | |
|----------------------------|------------------------------|
| 1) Resetting of indication | 5) Tripping Stage 3 |
| 2) Start Stage 1/ Stage 2 | 6) Tripping Stage 4 |
| 3) Tripping Stage 1 | 7) Start Stage 3/ Stage 4 |
| 4) Tripping Stage 2 | 8) Loss of auxiliary voltage |

Fig. 12 Terminal diagram 1MRK 001 026-LAA

The terminal designations include the item designation number of the unit followed by the terminal number marked on the rear of the terminal socket.

For plug-in units size 2H an additional figure 1 or 3 defines if the terminal is in the upper resp. lower part of the assembly. Compare terminal designations 107:118 and 107:318 in Fig. 13.

Fig. 13 shows the rear of protection assembly RAFK, Order No. 1MRK 001 025-LA. The position of the terminals, which are used for external connections according to connection diagram 1MRK 001 026-LAA, is shown.

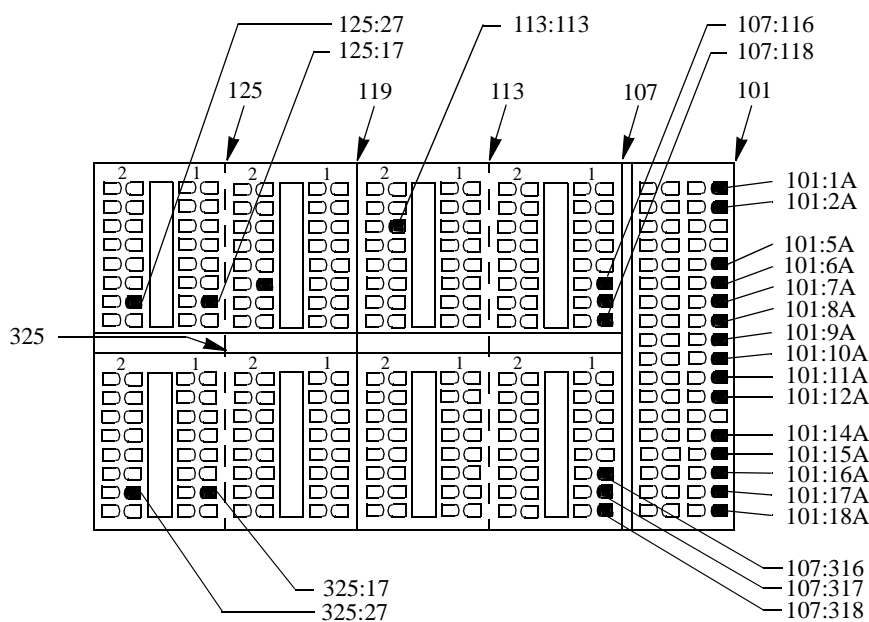

Fig. 13 Location of the terminals shown on diagram 1MRK 001 026-LAA

7.2 Testing

Secondary injection testing

The standard relays (Order No's 1MRK 001 0xx-xA) are provided with the COMBITEST test switch type RTXP 18.

When the test-plug handle RTXP 18 is inserted in the test switch, preparations for testing are automatically carried out in the proper sequence, i.e. blocking of the tripping circuits, opening of the VT circuits and making relay terminals accessible for testing.

When the test handle is in the intermediate position, only the tripping circuits are opened. When the test handle is fully inserted, the relay is completely disconnected from the current transformers and ready for secondary injection testing.

Relays which are not provided with test switch have to be tested in the proper way from external circuit terminals.

For testing of frequency relays, a test apparatus with sinusoidal voltage output of variable frequency should be available, e.g. the FREJA computer aided test system with built-in timer and settable rate-of-change of frequency (df/dt).

Suitable test equipment:

- Test set FREJA
- Multimeter or voltmeter, Class 0,5 or better
- RTXH 18 test plug with test leads

Fig. 14 shows as an example the connection of test set FREJA for secondary testing of the two-stage frequency protection RAFK 1, Connection Diagram 1MRK 001 026-EAA. When testing, even the actual circuit diagram of the protection, which shows the internal connections, should be available.

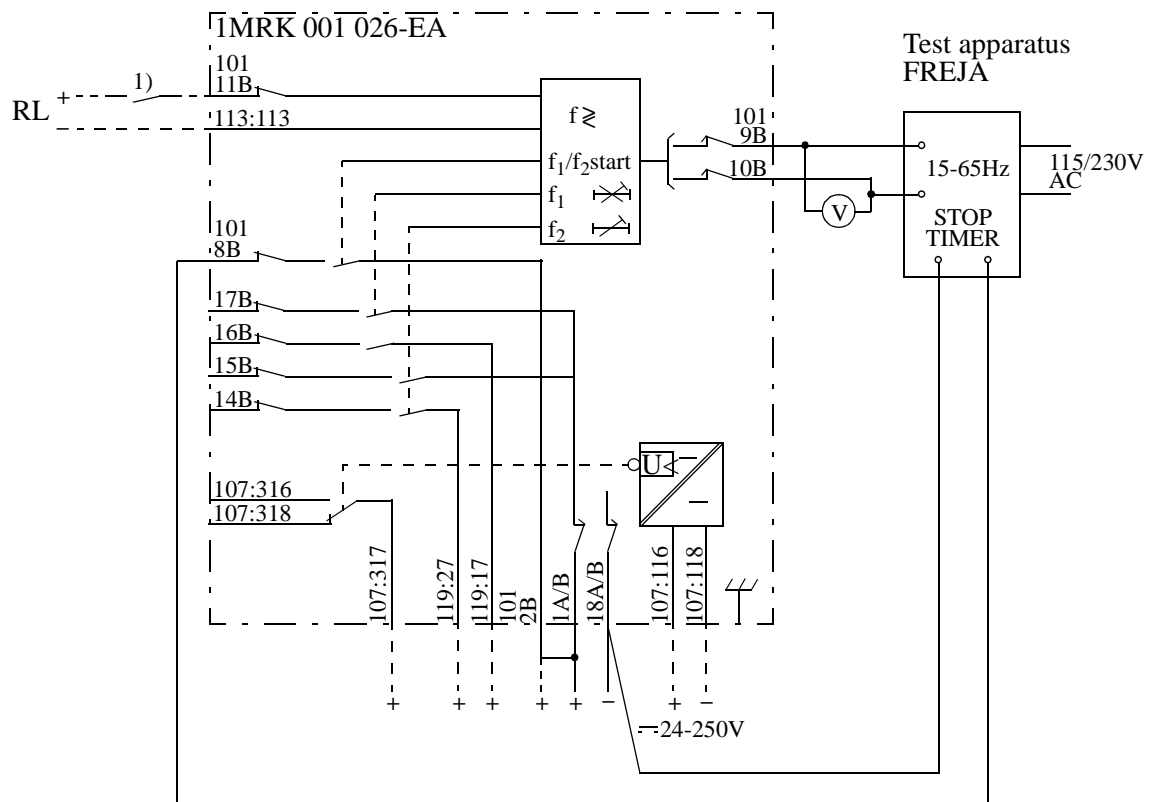

Fig. 14 Connection of test apparatus to RAFK 1.

1. Insert the test-plug into the test switch. Connect the test set and the voltmeter according to Fig.14. Auxiliary voltage shall be connected to terminals 101:1A and 101:2A. Interconnect terminals 1 and 2 on the test handle to get output voltage to test terminal 8 when the start function output relay for f1 or f2 operates.

2. Select over-frequency or under-frequency function and the operate (start) frequency for stage f1. Set f2 temporarily to operate after a greater frequency deviation from normal frequency than stage f1. Make the

appropriate setting for the blocking voltage. Guide for the setting of the switches and potentiometers on the front of the RXFK 2H relay is given in Section 4.

3. Increase slowly the injection voltage frequency up the start level for overfrequency function or decrease slowly the frequency to start level for under-frequency function and adjust the potentiometer setting. Check that the LED indicator for Start operates.

4. Set the time delay for stage f1 and move the timer stop wire to test terminal 17. For overfrequency function, check the operate time when the frequency is instantly increased from $(f_{\text{set}} - 0,5 \text{ Hz})$ to $(f_{\text{set}} + 0,5 \text{ Hz})$. For underfrequency function, check the operate time when the frequency is instantly decreased from $(f_{\text{set}} + 0,5 \text{ Hz})$ to $(f_{\text{set}} - 0,5 \text{ Hz})$.

5. Move the timer stop wire to test terminal 16 and check that trip output is obtained when stage f1 operates and voltage is supplied to terminal 119:17.

6. Move the timer stop wire to test terminal 15. Select over-frequency or under-frequency function and set the operate (start) frequency for stage f2. Set temporarily the time delay for stage f2 to min. value and check the start frequency. Set the time delay of stage f2 to the correct value and check the operate time as indicated above.

7. If function df/dt is selected for stage f2, the start value is similarly checked with the timer to minimum.

8. Move the timer stop wire to test terminal 14 and check that trip output is obtained when stage f2 operates and voltage is supplied to terminal 119:27.

9. Check that the frequency functions are blocked when the output voltage from the test apparatus is below the set blocking level.

10. Set the binary input switch to the correct position and check the function of the binary input by connecting voltage +RL to test terminal 11.

11. Remove the test handle and check that all indicating LED's and flags are reset. Insert the plastic plug in the hole of the resetting push-button.

For frequency protections with more than two stages, each RXFK 2H measuring unit is checked as indicated above.

7.3 Commissioning

The commissioning work includes check of all external circuits connected to the protection and check of voltage ratio for the Voltage transformers.

The DC circuits and tripping circuits should be checked, including operation of the circuitbreaker(s).

8 Maintenance

Under normal conditions, the over/underfrequency protection relays require no special maintenance. The covers should be mounted correctly in position and the holes for the resetting knobs sealed with plastic plugs.

In exceptional cases, burned contacts on the output relays can be dressed with a diamond file.

Under normal operating conditions and when the surrounding atmosphere is of non-corrosive nature, it is recommended that the relays be routine tested every four to five years.

9 Circuit and terminal diagrams

The table below shows the different variants of the over/under frequency protection RAFK.

Type	Number of frequency stages	Test switch	DC-DC converter	Tripping relay(s)	Ordering No. 1MRK 001	Circuit Diagram 1MRK 001	Terminal diagram 1MRK 001	Diagrams
RAFK 1	2	x			025-BA	026-BA	026-BAA	On request
RAFK 1	2		x		025-CA	026-CA	026-CAA	On request
RAFK 1	2	x	x		025-DA	026-DA	026-DAA	On request
RAFK 1	2	x	x	x	025-EA	026-EA	026-EAA	Fig. 15,16
RAFK 2	4	x			025-GA	026-GA	026-GAA	On request
RAFK 2	4		x		035-HA	026-HA	026-HAA	On request
RAFK 2	4	x	x		025-KA	026-KA	026-KAA	On request
RAFK 2	4	x	x	x	025-LA	026-LA	026-LAA	Fig 17, 18
RAFK 3	6	x			025-NA	026-NA	026-NAA	On request
RAFK 3	6		x		025-YA	026-YA	026-YAA	On request
RAFK 3	6	x	x		025-PA	026-PA	026-PAA	On request
RAFK 3	6	x	x	x	025-ZA	026-ZA	026-ZAA	Fig 19, 20

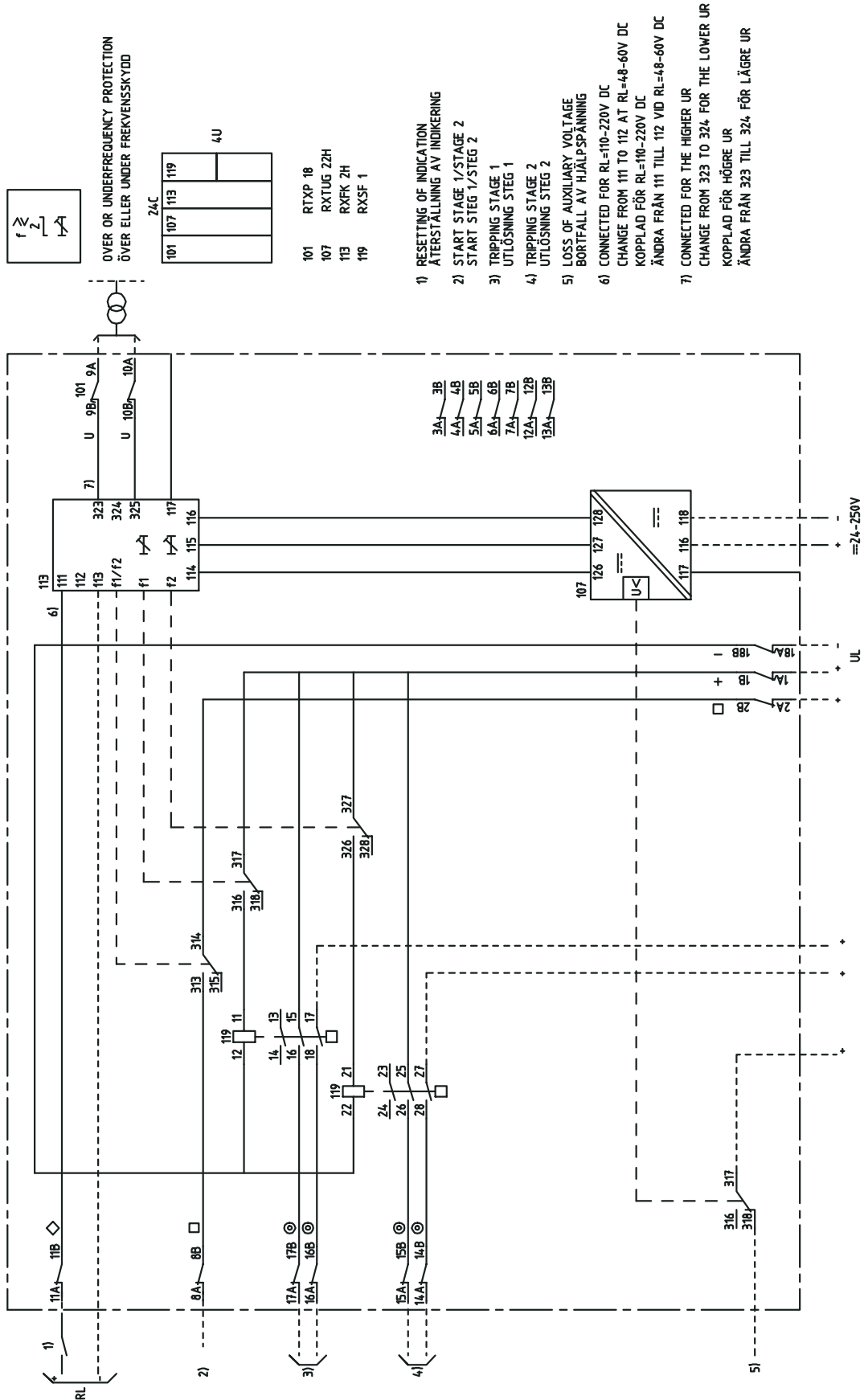
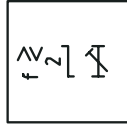

Fig. 15 Circuit diagram 1MRK 001 026-EA



OVER- OR UNDERFREQUENCY PROTECTION
ÖVER ELLER UNDERFREKVENSSKYDD

- 1) RESETTING OF INDICATION
ÅTERSTÄLLNING AV INDIKERING
- 2) START STAGE 1/STAGE 2
START STEG 1/STEG 2
- 3) TRIPPING STAGE 1
UTLÖSNING STEG 1
- 4) TRIPPING STAGE 2
UTLÖSNING STEG 2
- 5) LOSS OF AUXILIARY VOLTAGE
BORTFALL AV HJÄLPSPÄNNING

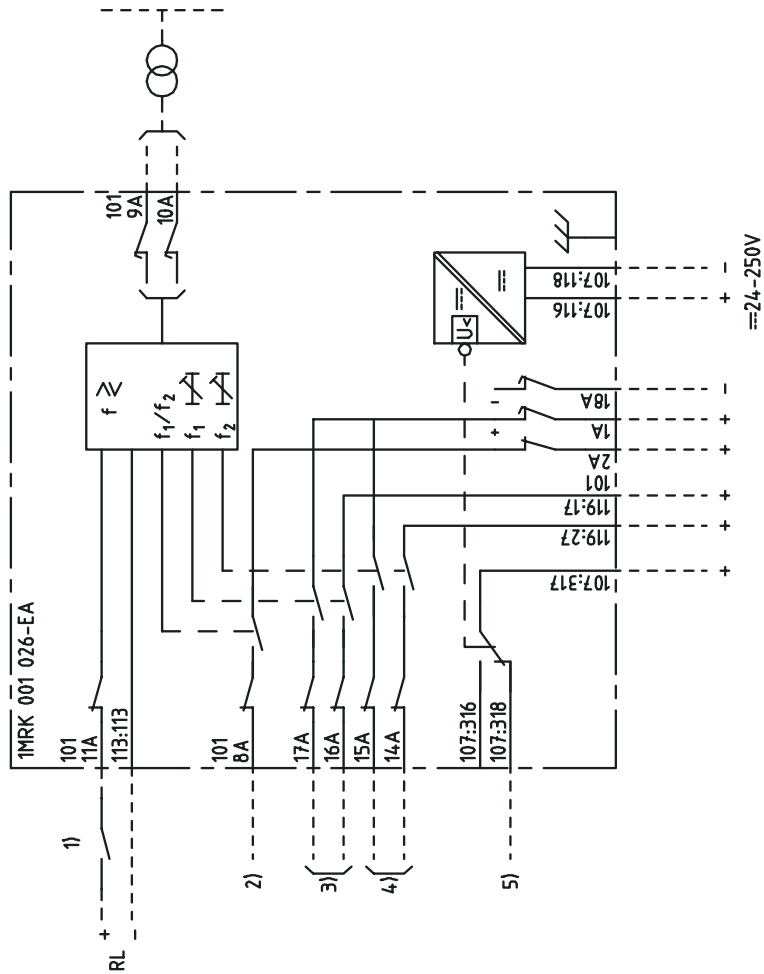

Fig. 16 Terminal diagram 1MRK 001 026-EAA

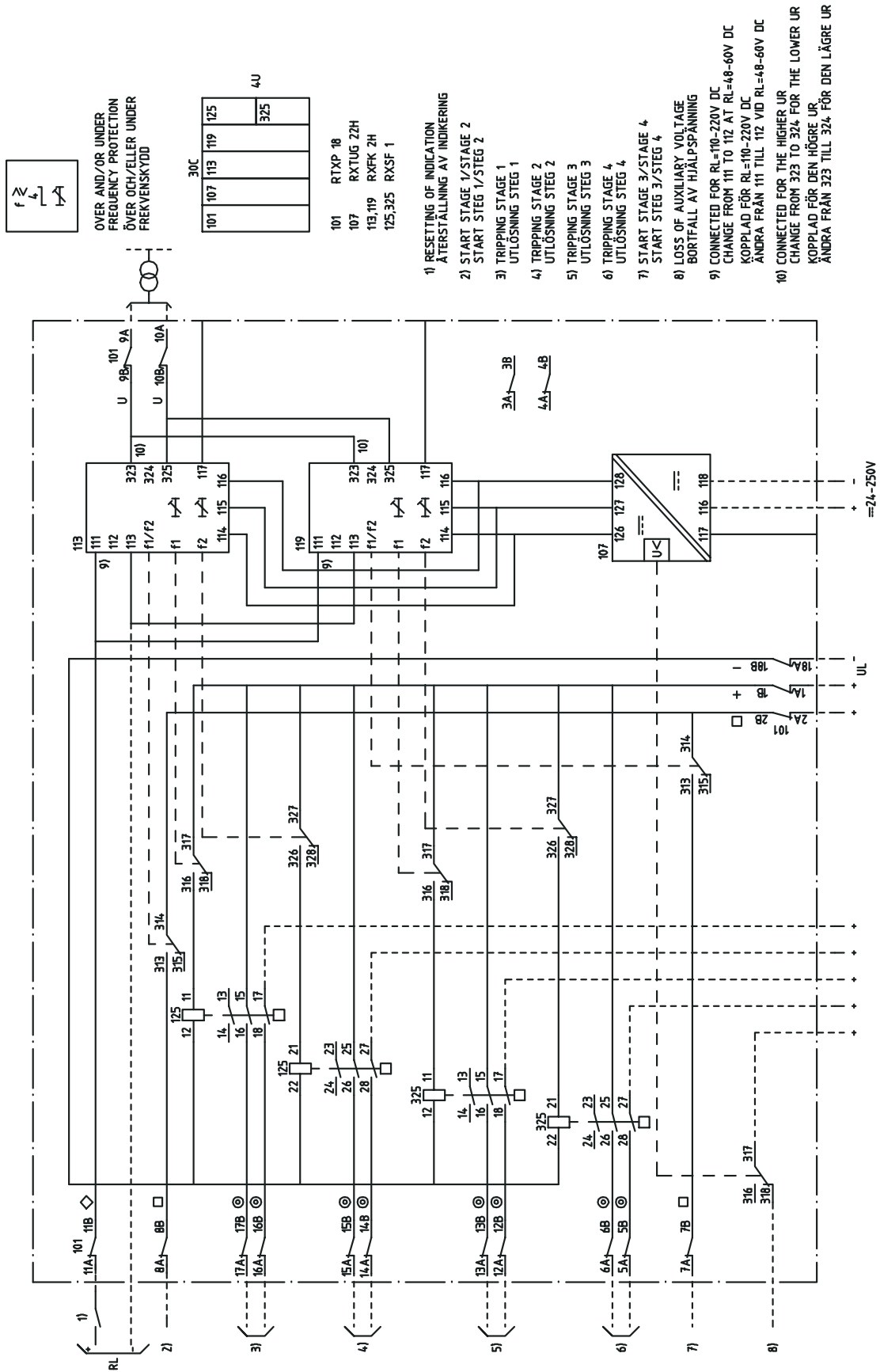

Fig. 17 Circuit diagram 1MRK 001 026-LA



OVER AND/OR UNDERFREQUENCY PROTECTION
ÖVER OCH/ELLER UNDERFREKVENSSKYDD

- 1) RESETTING OF INDICATION
ÅTERSTÄLLNING AV INDIKERING
- 2) START STAGE 1/STAGE 2
START STEG 1/STEG 2
- 3) TRIPPING STAGE 1
UTLÖSNING STEG 1
- 4) TRIPPING STAGE 2
UTLÖSNING STEG 2
- 5) TRIPPING STAGE 3
UTLÖSNING STEG 3
- 6) TRIPPING STAGE 4
UTLÖSNING STEG 4
- 7) START STAGE 3/STAGE 4
START STEG 3/STEG 4
- 8) LOSS OF AUXILIARY VOLTAGE
BORTFALL AV HJÄLPSPÄNNING

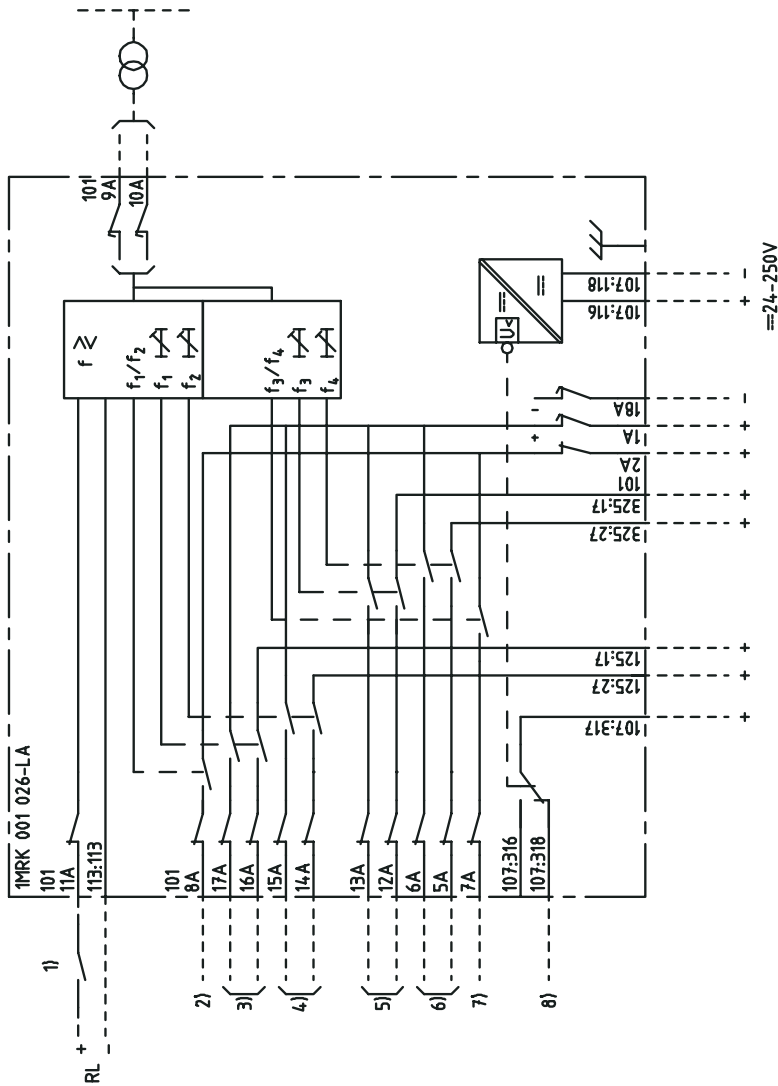

Fig. 18 Terminal diagram 1MRK 001 026-LAA

Version 1
 January 1998

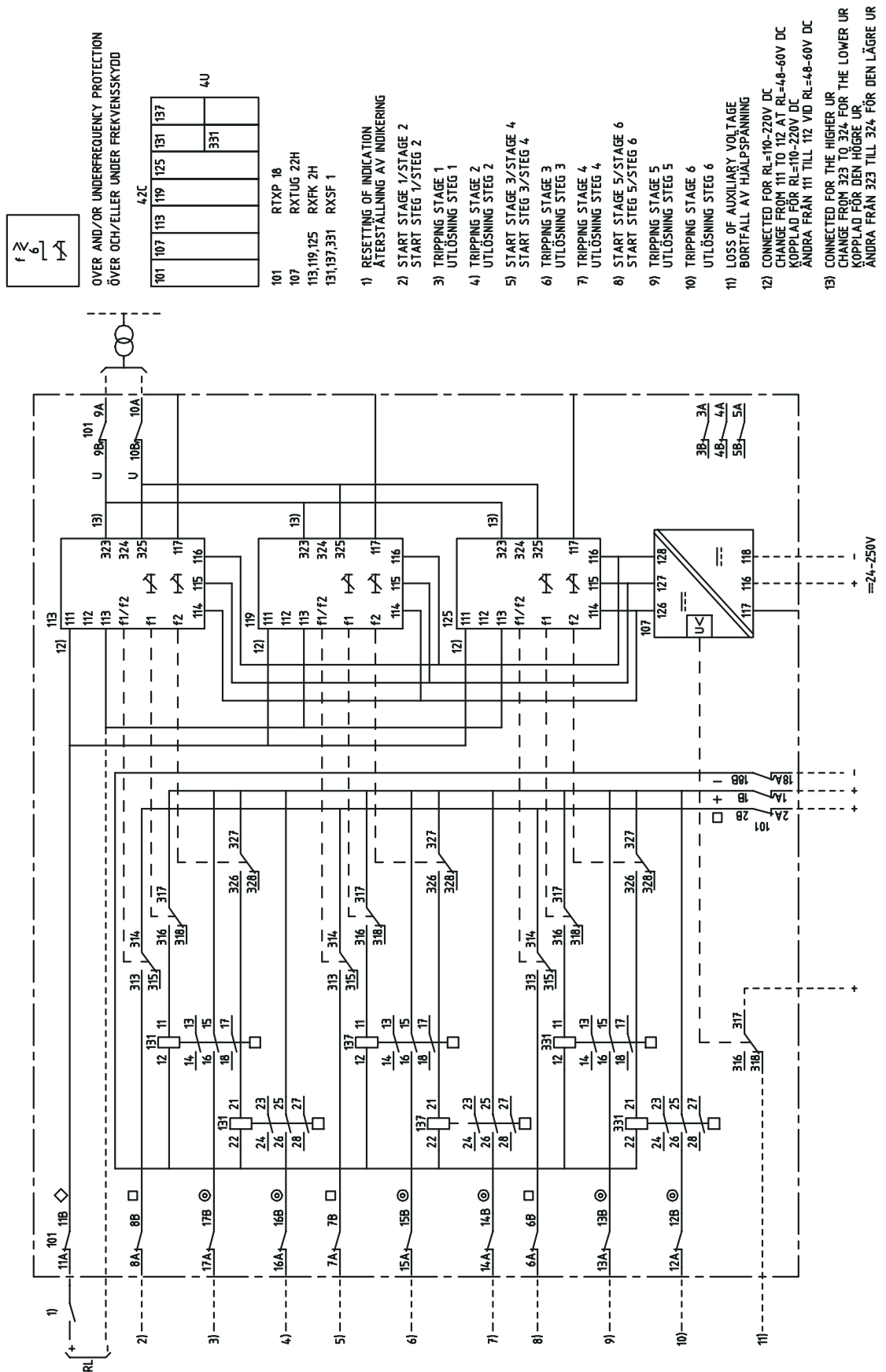
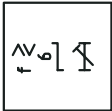
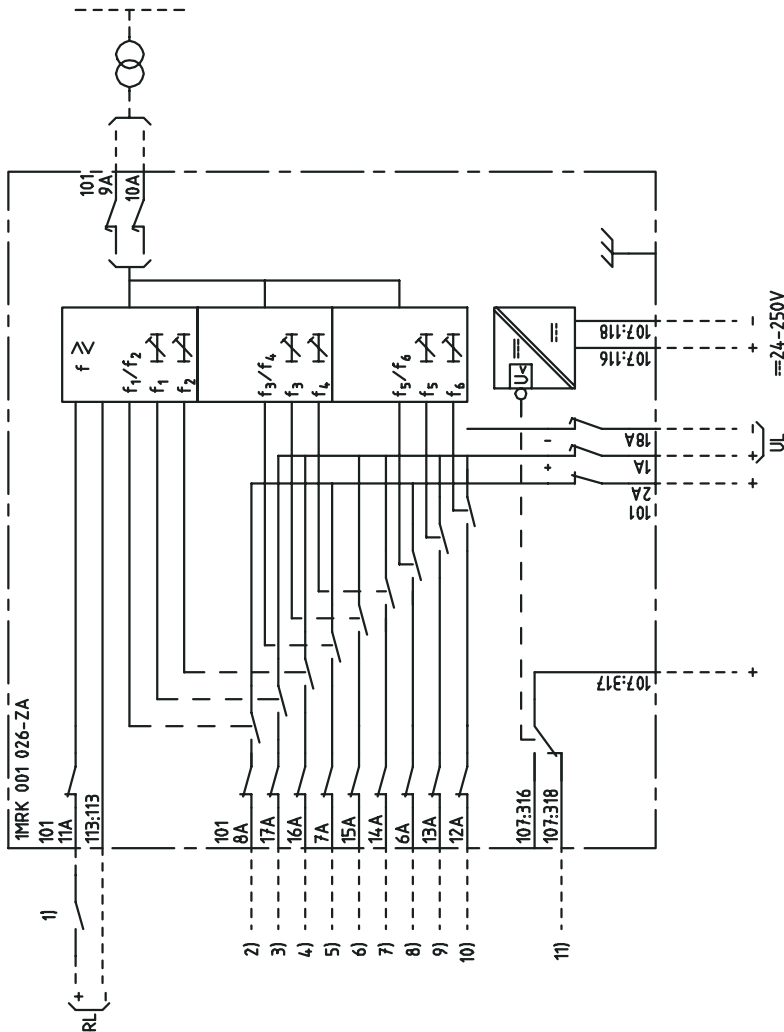

Fig. 19 Circuit diagram 1MRK 001 026-ZA



OVER AND/OR UNDERFREQUENCY PROTECTION
ÖVER OCH/ELLER UNDERFREKVENSSKYDD



- 1) RESETTING OF INDICATION
ÅTERSTÄLLNING AV INDIKERING
- 2) START STAGE 1/STAGE 2
START STEG 1/STEG 2
- 3) TRIPPING STAGE 1
UTLÖSNING STEG 1
- 4) TRIPPING STAGE 2
UTLÖSNING STEG 2
- 5) START STAGE 3/STAGE 4
START STEG 3/STEG 4
- 6) TRIPPING STAGE 3
UTLÖSNING STEG 3
- 7) TRIPPING STAGE 4
UTLÖSNING STEG 4
- 8) START STAGE 5/STAGE 6
START STEG 5/STEG 6
- 9) TRIPPING STAGE 5
UTLÖSNING STEG 5
- 10) TRIPPING STAGE 6
UTLÖSNING STEG 6
- 11) LOSS OF AUXILIARY VOLTAGE
BORTFALL AV HJÄLPSPÄNNING

Fig. 20 Terminal diagram 1MRK 001 026-ZAA

ABB Network Partner AB

S-721 71 Västerås
Sweden

Tel +46 21 321300

Fax +46 21 146918